

SITE PLAN

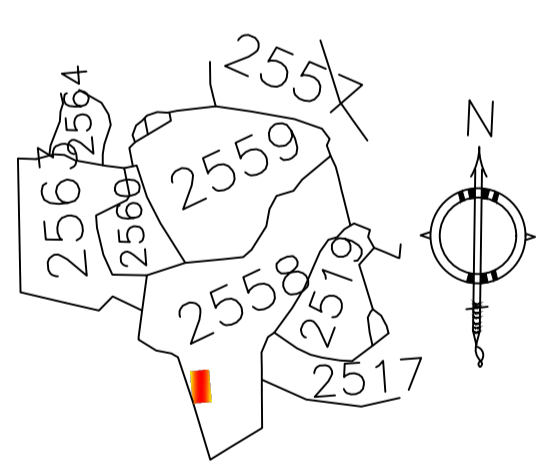
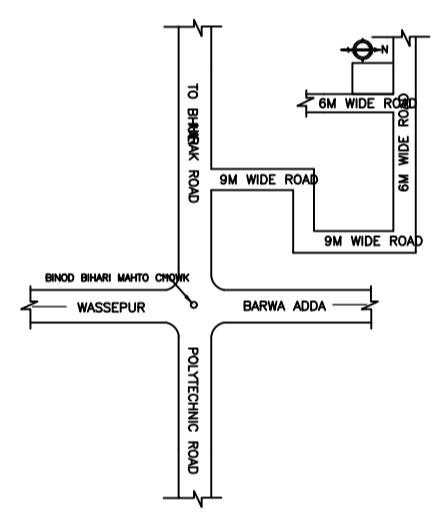

KEY PLAN

SCHEDULE OF DOOR:

BUILDING NAME	NAME	LENGTH	HEIGHT	NOS
A (A)	D	0.89	2.10	01
A (A)	D	0.90	2.10	12

SCHEDULE OF WINDOW/VENTILATION:

BUILDING NAME	NAME	LENGTH	HEIGHT	NOS
A (A)	W	1.56	1.20	02
A (A)	W	1.80	1.20	12
A (A)	W	2.72	1.20	02

Building :A (A)

Floor Name	Total Built Up Area (Sq.mt.)	Proposed FAR Area (Sq.mt.) Resi.	Total FAR Area (Sq.mt.)	Total Consumed Additional FAR Area (Sq.mt.)	Tnmt (No.)
Ground Floor	81.68	81.68	81.68	81.68	01
First Floor	81.68	81.68	81.68	81.68	00
Terrace Floor	0.00	0.00	0.00	0.00	00
Total :	163.36	163.36	163.36	163.36	01
Total Number of Same Buildings :	1				
Total :	163.36	163.36	163.36	163.36	01

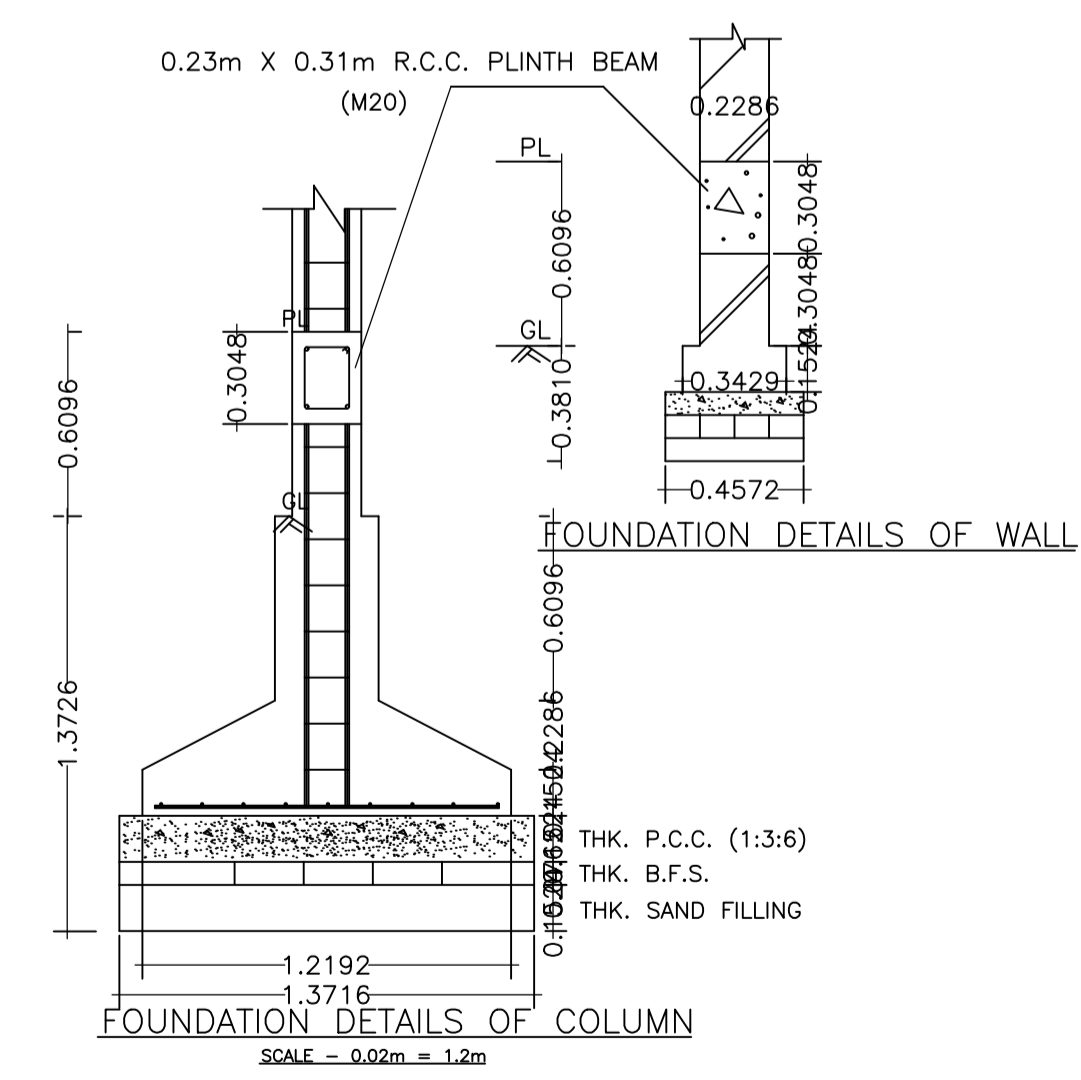
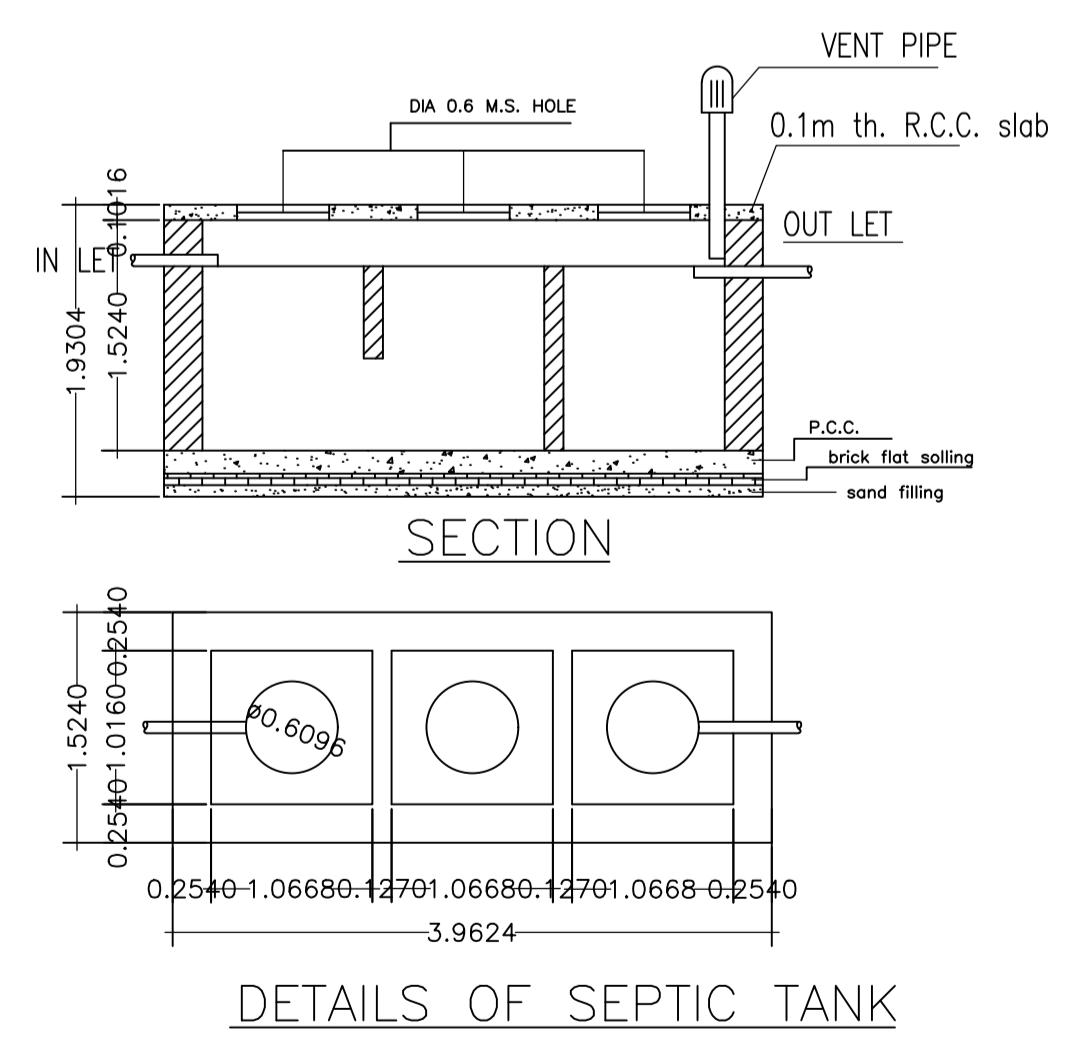
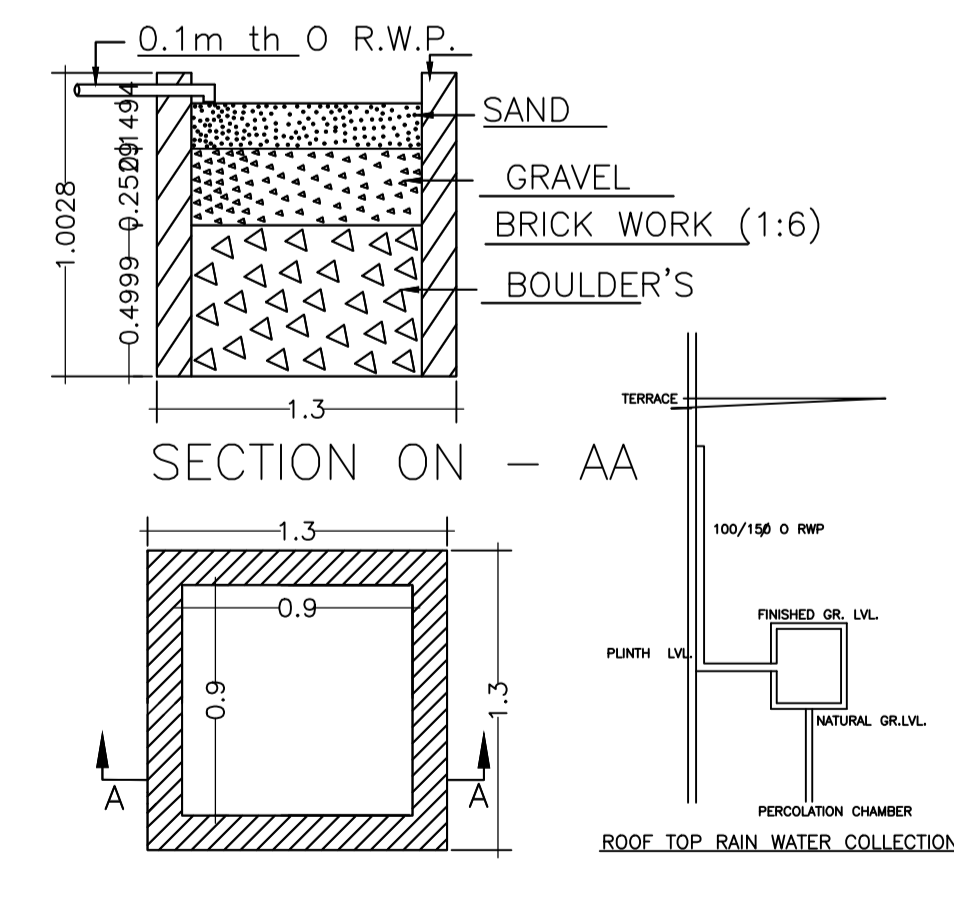
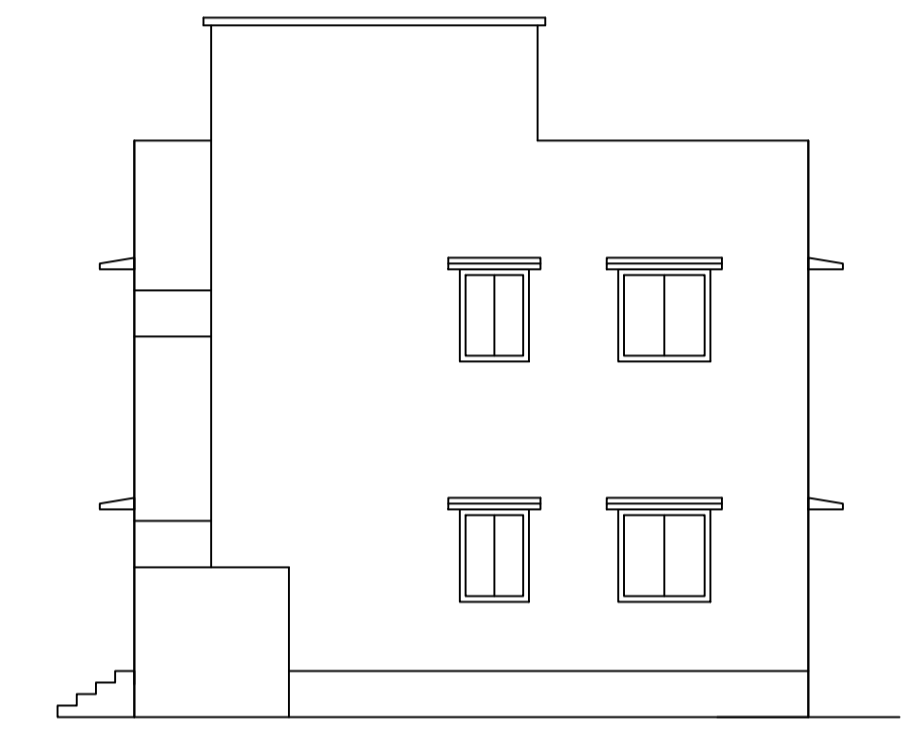
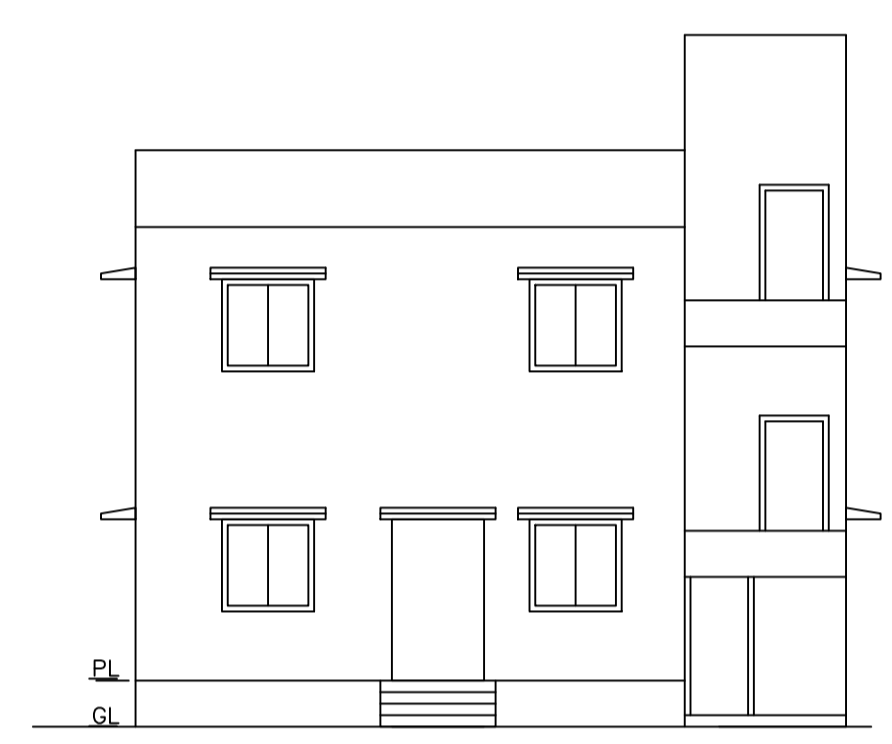
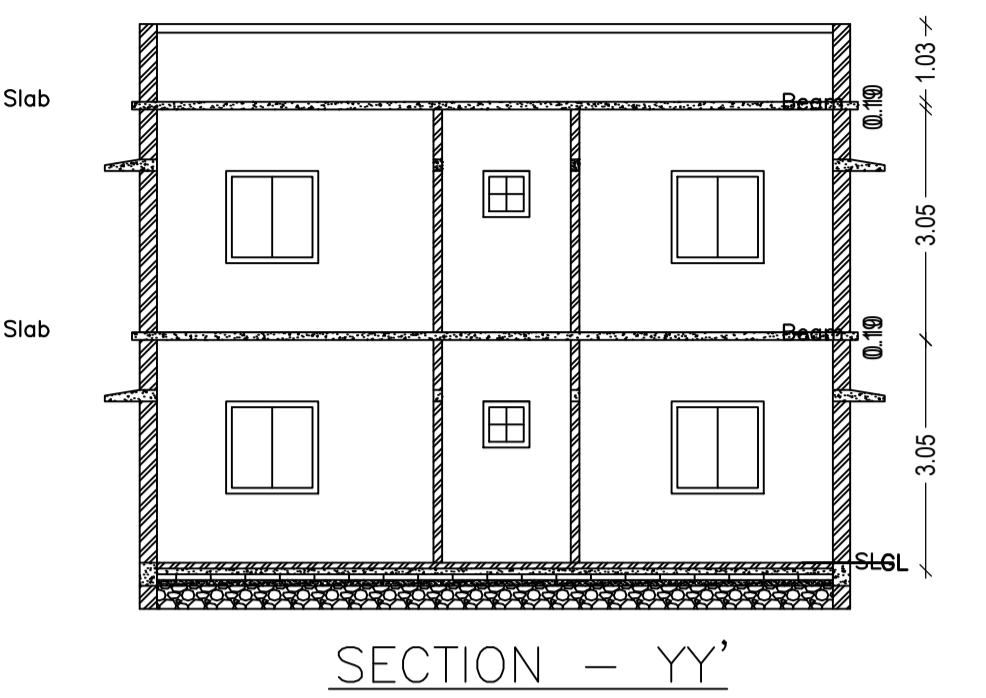
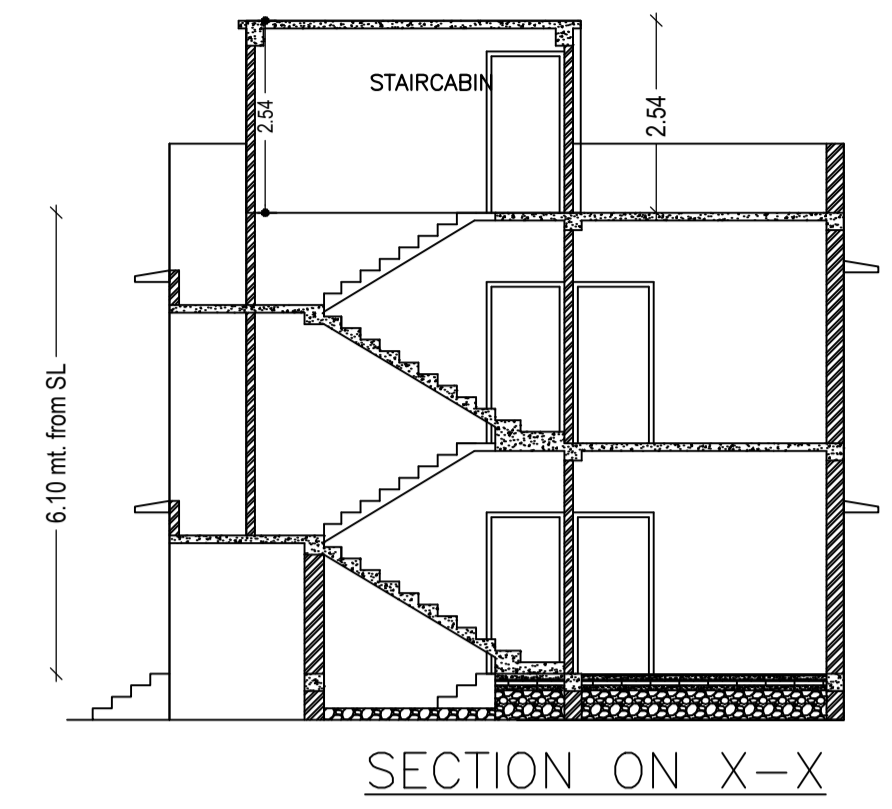

Proposal Basic Information

Proposal File No.	MADA/0053/2020
Owner Name	SRI ABHISHEK KUMAR SINGH
Khata No	OLD KHATA NO-72,NEW KHATA NO-82
Plot No	OLD PLOT NO. 2558, NEW PLOT NO. 4054
Village Name	Bara Pichari
Use	Residential
SubUse	Bungalow/ Dwelling / Non Apartment

AREA STATEMENT MINERAL AUTHORITY

Version No. : 1.0.54	Version Date: 16/10/2020		
Region: JHARKHAND URBAN LOCAL BODIES	Plot Use: Residential		
District: DHANBAD	Plot SubUse: Bungalow/ Dwelling / Non Apartment		
Authority: MINERAL AREA DEVELOPMENT AUTHORITY	PlotNearby/ReligiousStructure: NA		
Inward No: MADA/0053/2020	Plot/SubPlot No: OLD PLOT NO. 2558, NEW PLOT NO. 4054		
Application Type: General Proposal	North: Road Width - ROAD		
Project Type: Building Permission	South: Plot No. - SAME PLOT		
Nature of Development: New	East: Road Width - 6.0		
Location of Development Area: Old Area	West: Plot No. - SAME PLOT		
AREA DETAILS:			
AREA OF PLOT (Minimum)	(A)	SQ.MT.	138.85
NET AREA OF PLOT(Gross Plot Area - Deduction from Gross Plot area)	(A-Deductions)		138.85
Deduction for Balance Plot Area(from Gross Plot Area)			
Common Plot			23.63
Total			23.63
BALANCE AREA OF PLOT(Net Plot Area - Recreational/Amenity space)	(A-Deductions)		115.22
PLOT AREA FOR COVERAGE(Net Plot Area)	(A-Deductions)		138.85
Plot Area for FAR (Net Plot Area + Road/Widening Area)	(A-Deductions)		138.85
COVERAGE CHECK			
Permissible Coverage area (70.00 %)			97.19
Proposed Coverage Area (58.83 %)			81.68
Total Prop. Coverage Area (58.83 %)			81.68
Balance coverage area (11.17 %)			15.51
FAR CHECK			
Perm. FAR Area (2.50)			347.13
Total Perm. FAR area			347.13
Residential FAR			163.36
Proposed FAR Area			163.36
Total Proposed FAR Area			163.36
Consumed FAR (Factor)			1.18
Balance FAR Area			183.77
BUILT UP AREA CHECK			
Total Proposed BuiltUp Area			163.36
ARCHITECT (Regd)			RAM PRATAP SINGH
ENGINEER (Regd)			
SUPERVISOR (Regd)			
OWNER (Regd)			SRI ABHISHEK KUMAR SINGH
DEVELOPMENT AUTHORITY			LOCAL BODY

COLOR INDEX

PLOT BOUNDARY	Black
ABUTTING ROAD	Green
PROPOSED CONSTRUCTION	Red
COMMON PLOT	Yellow
ROAD WIDENING AREA	Blue
EXISTING (To be retained)	Orange
EXISTING (To be demolished)	White

Buildingwise Floor FAR Details

Floor Name	Building Name A (A)		Total	
	Proposed Built Up Area (Sq.mt.)	Proposed FAR Area (Sq.mt.)	Total Proposed Built Up Area (Sq.mt.)	Total FAR Area (Sq.mt.)
Ground Floor	81.68	81.68	81.68	81.68
First Floor	81.68	81.68	81.68	81.68
Terrace Floor	0.00	0.00	0.00	0.00
Total :	163.36	163.36	163.36	163.36

Building USE/SUBUSE Details

Building Name	Building Use	Building SubUse	Building Structure
A (A)	Residential	Residential Bldg/Apartment	Non-Highrise

FAR & Tenement Details (Table 4c-1)

Building	No. of Same Bldg	Total Built Up Area (Sq.mt.)	Proposed FAR Area (Sq.mt.) Resi.	Total FAR Area (Sq.mt.)	Total Consumed Additional FAR Area (Sq.mt.)	Tnmt (No.)
A (A)	1	163.36	163.36	163.36	163.36	01
Grand Total :	1	163.36	163.36	163.36	163.36	01

UnitBUA Table for Building :A (A)

FLOOR	Name	UnitBUA Type	UnitBUA Area	Carpet Area	No. of Rooms	No. of Tenement
GROUND FLOOR-PLAN	SPLIT 1	FLAT	163.36	163.33	6	1
FIRST FLOOR-PLAN	SPLIT 1	FLAT	0.00	0.00	6	0
Total:	-	-	163.36	163.33	12	1

LTP NAME AND SIGNATURE	STRUCTURAL ENG'S NAME AND SIGNATURE	BUILDER NAME AND SIGNATURE	DIGITAL SIGNATURE
RAM PRATAP SINGH MADA/ARC/0024/2019			

Proposal Basic Information

Proposal File No.	MADA/PI/0053/2020
Owner Name	SRI ABHISHEK KUMAR SINGH
Khata No	OLD KHATA NO-72, NEW KHATA NO-82
Plot No	OLD PLOT NO. 2558, NEW PLOT NO. 4054
Village Name	Bara Pichari
Use	Residential
SubUse	Bungalow/ Dwelling / Non Apartment

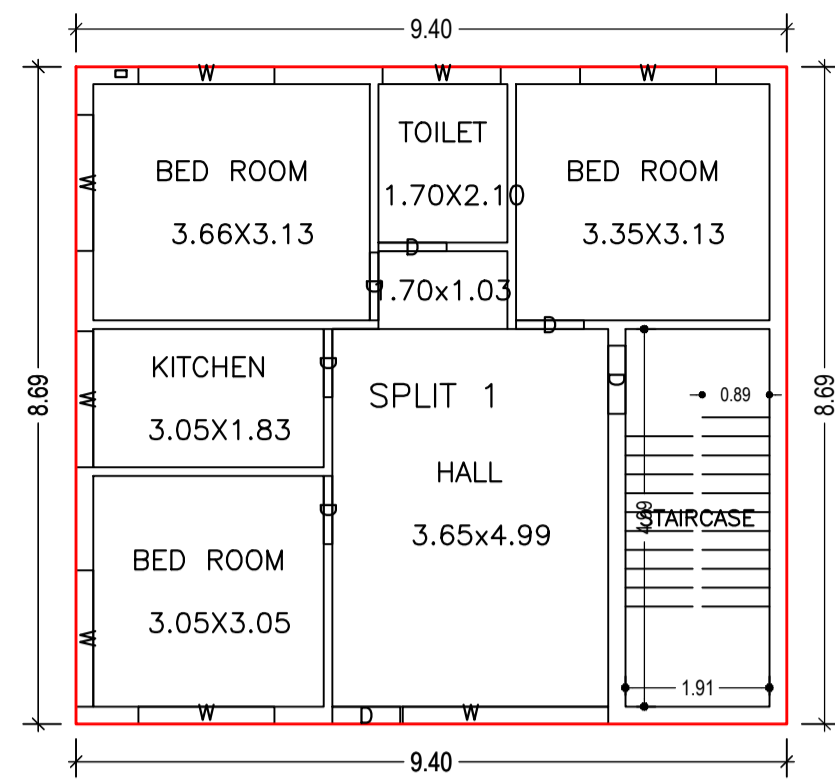

GROUND FLOOR PLAN
(Proposed)
(SCALE 1:100)

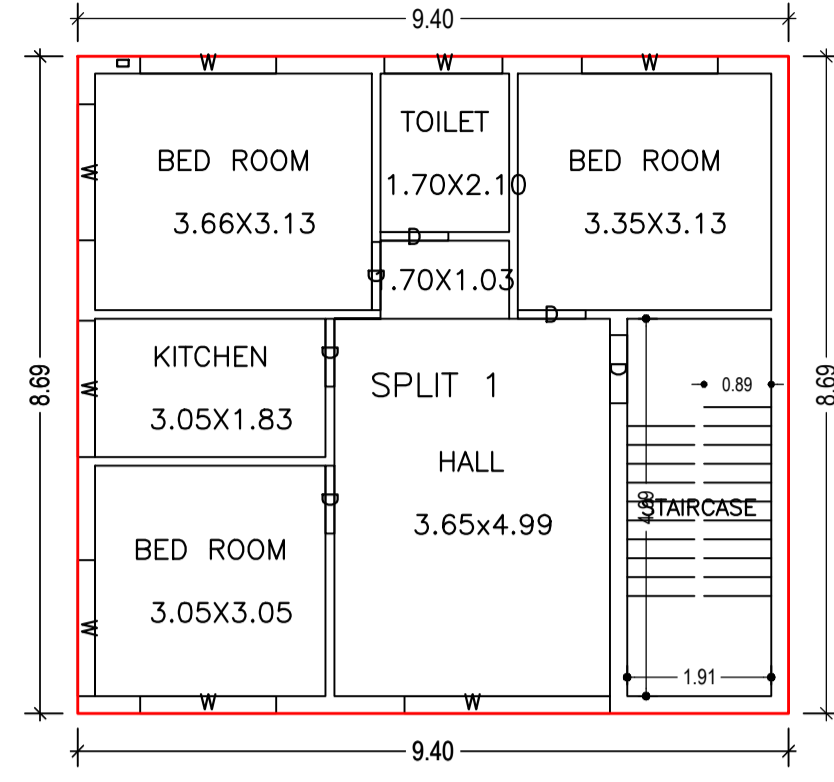

FIRST FLOOR PLAN
(Proposed)
(SCALE 1:100)

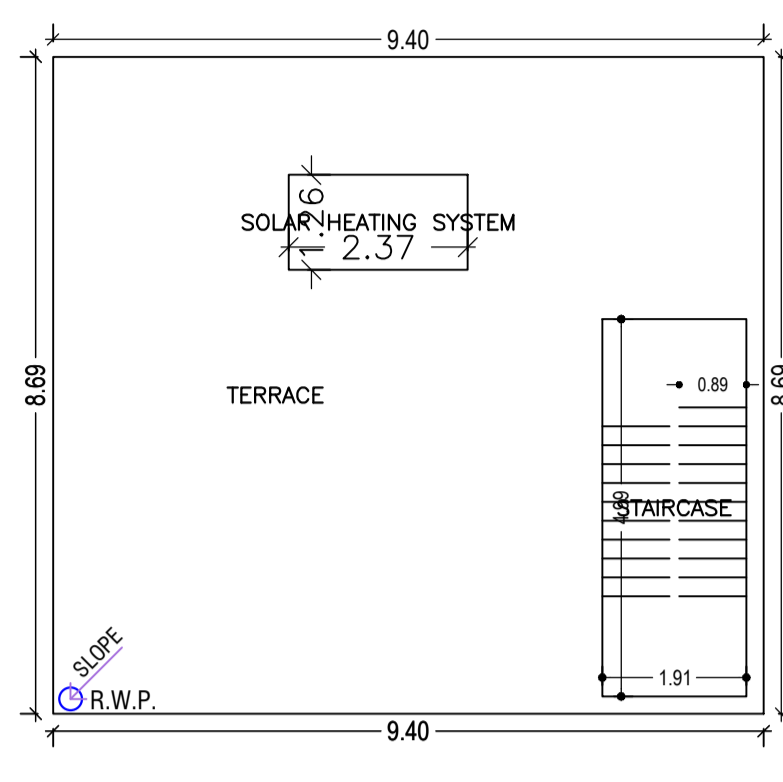

TERRACE FLOOR PLAN
(SCALE 1:100)

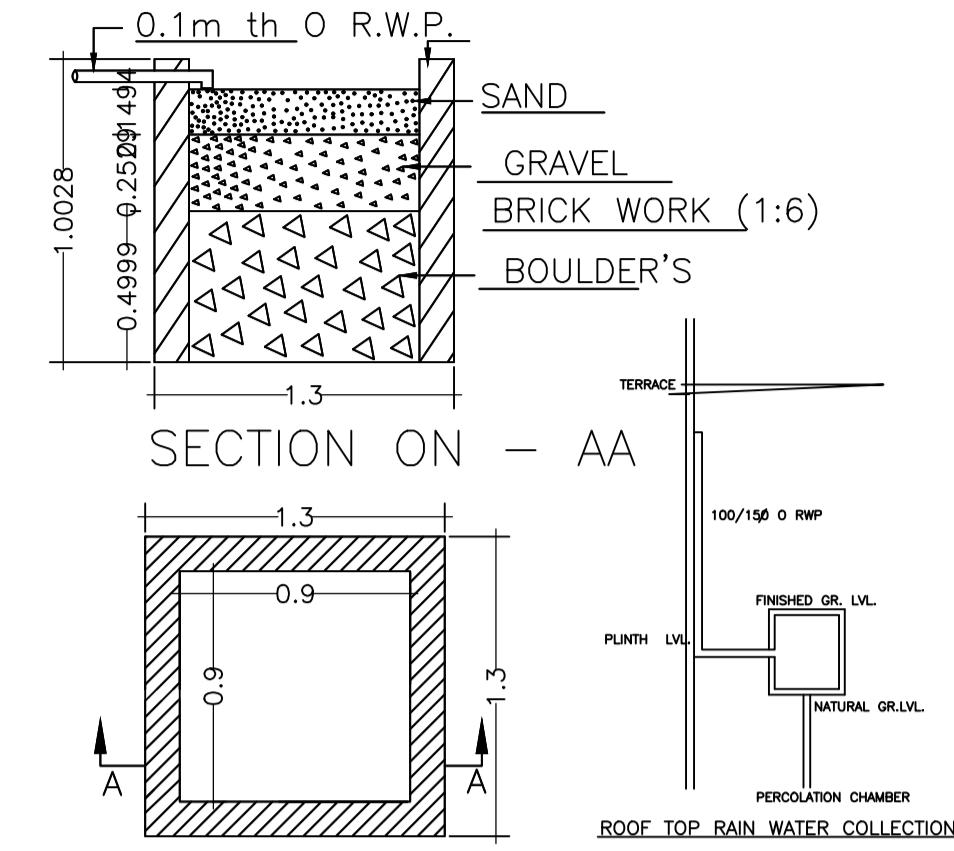
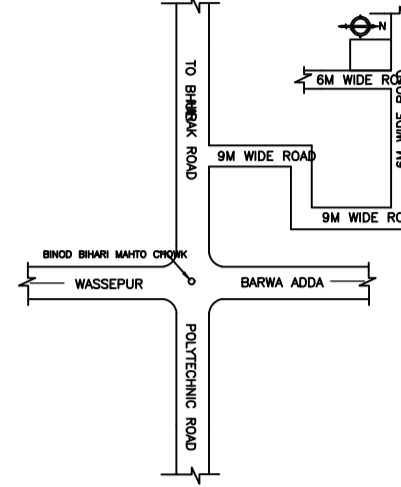

DETAIL'S OF WATER HARVESTING

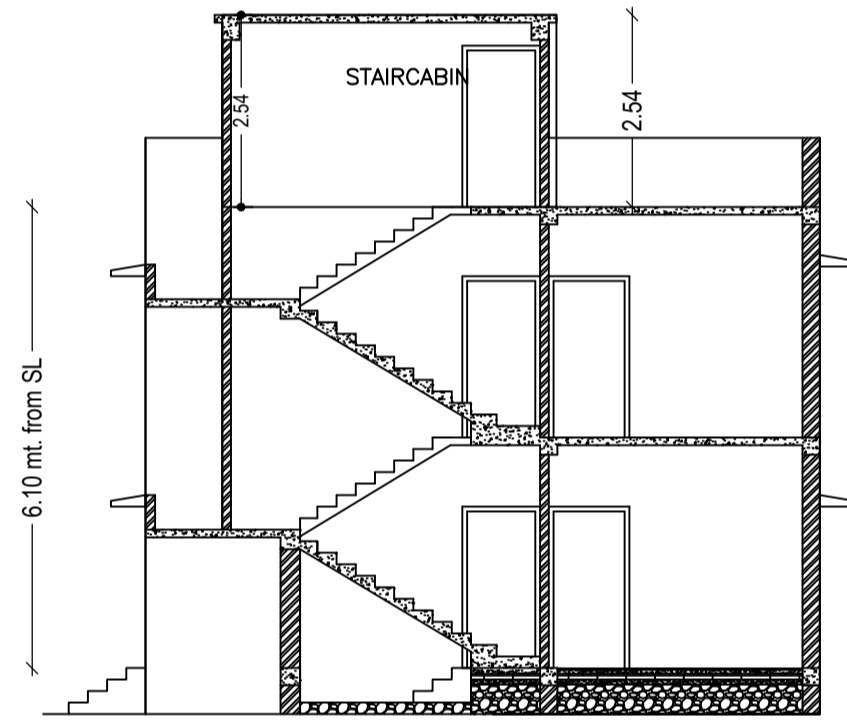

SECTION ON X-X

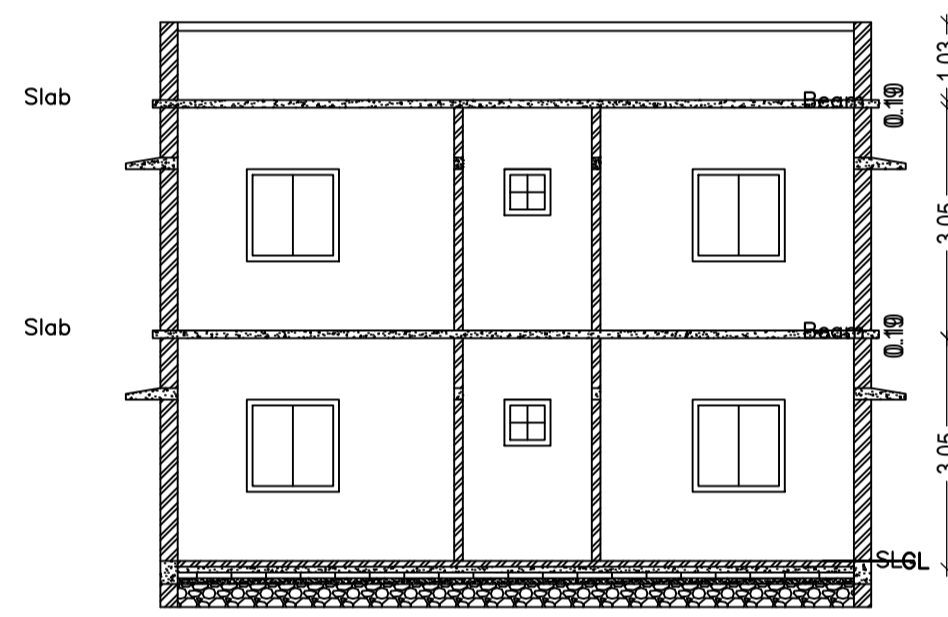

SECTION - YY'

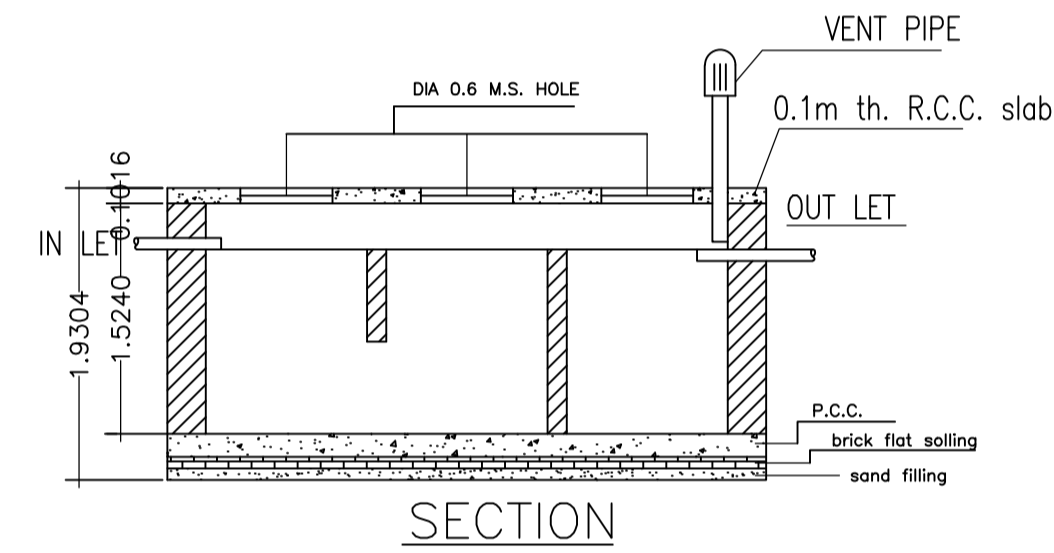

SECTION

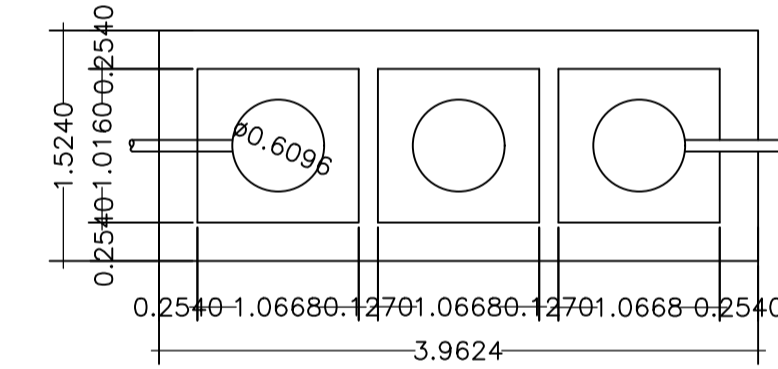

DETAILS OF SEPTIC TANK

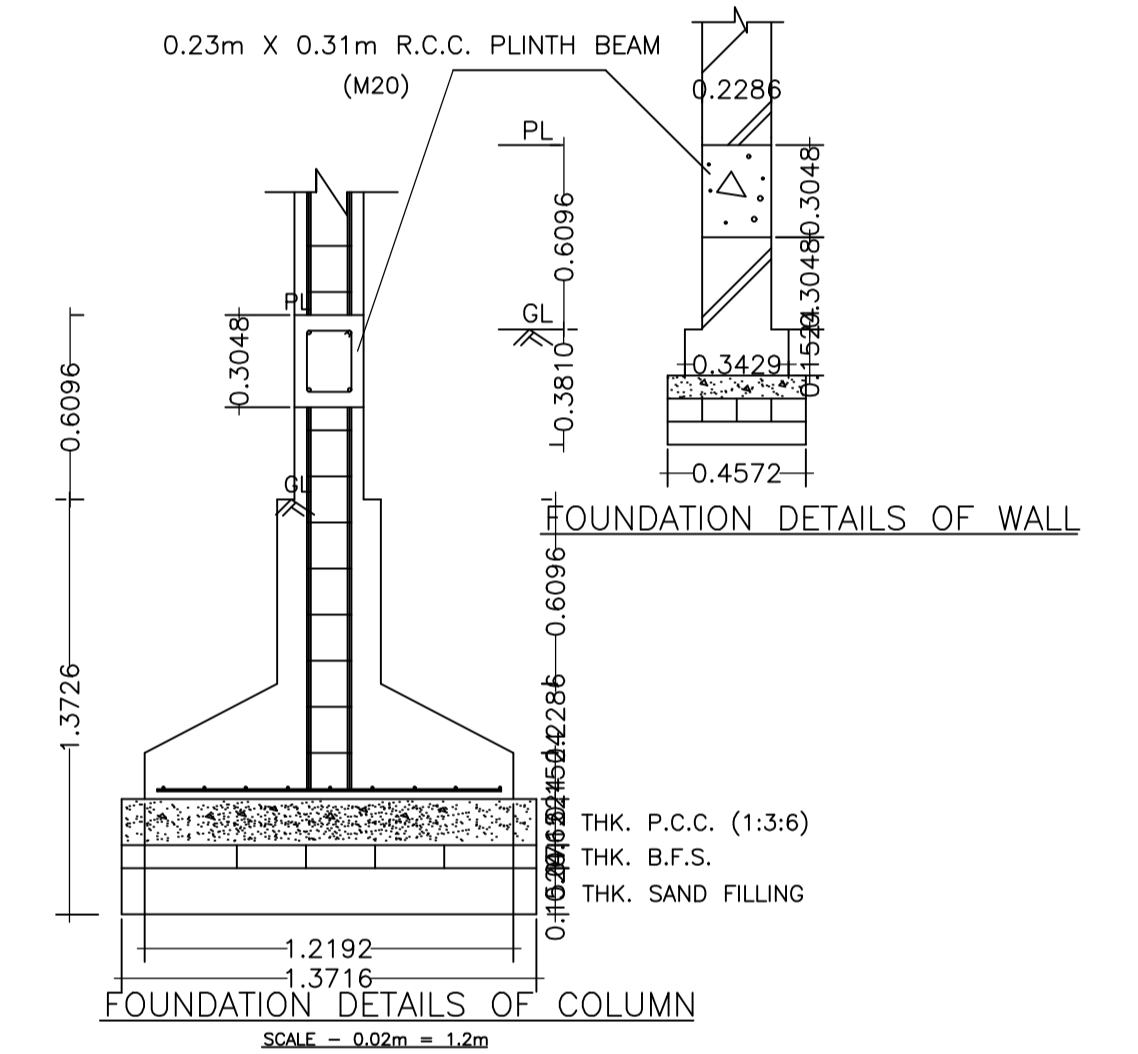

FOUNDATION DETAILS OF WALL

FOUNDATION DETAILS OF COLUMN

SCALE = 0.02m = 1.2m

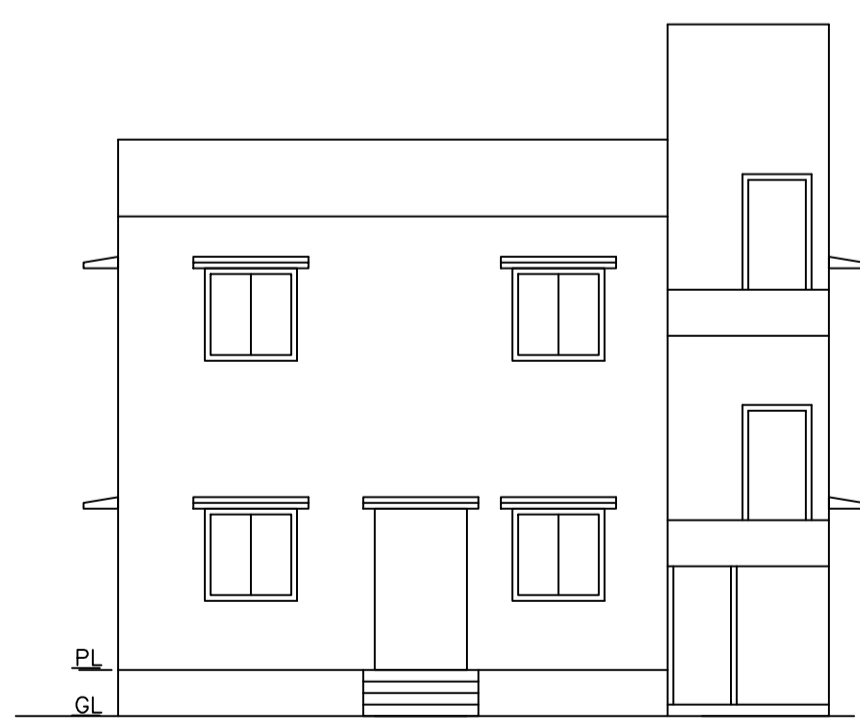

FRONT ELEVATION

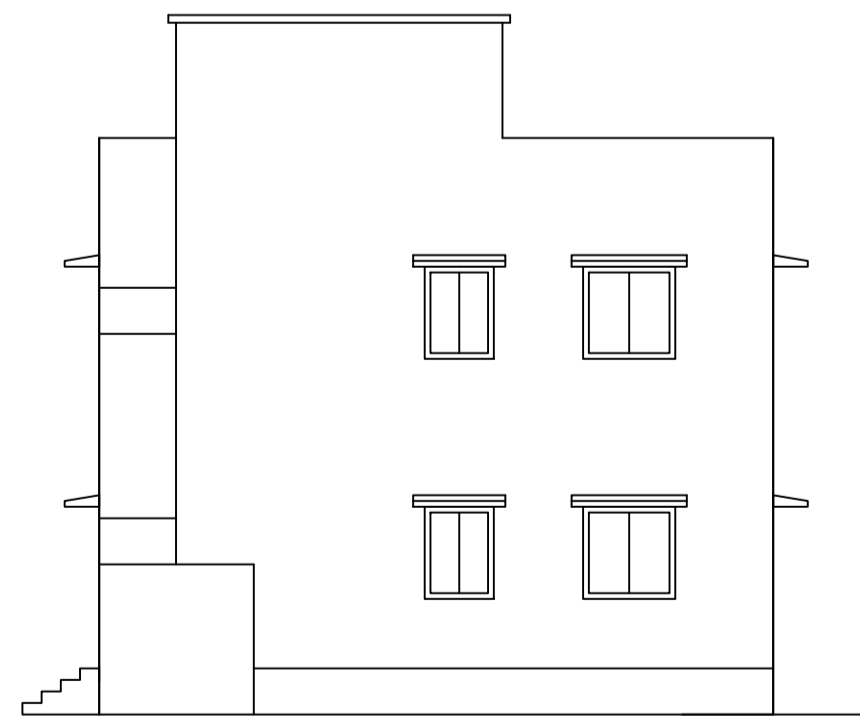

RIGHT ELEVATION

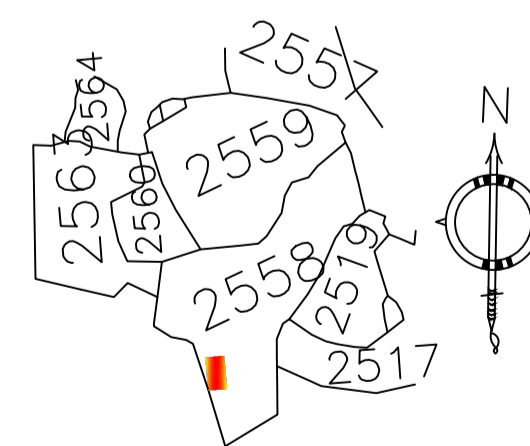

KEY PLAN

LTP NAME AND SIGNATURE	STRUCTURAL ENG'S NAME AND SIGNATURE	BUILDER NAME AND SIGNATURE	DIGITAL SIGNATURE
RAM PRATAP SINGH MADA/ARC/0024/2019			