

Proposal Basic Information

Proposal File No.	MADA/BP/0057/2020
Owner Name	SMT KAUSHALYA DEVI
Khata No	OLD : 101 ; NEW : 243
Plot No	OLD : 846 ; NEW : 1933
Village Name	Damodarpur
Use	Residential
SubUse	Bungalow/ Dwelling / Non Apartment

AREA STATEMENT MINERAL AREA DEVELOPMENT AUTHORITY	VERSION NO.: 1.0.50 VERSION DATE: 16/10/2020
PROJECT DETAIL:	
Region: JHARKHAND URBAN LOCAL BODIES	Plot Use: Residential
District: DHANBAD	Plot SubUse: Bungalow/ Dwelling / Non Apartment
Authority: MINERAL AREA DEVELOPMENT AUTHORITY	PlotNearby/ReligiousStructure: NA
Inward No: MADA/BP/0057/2020	Plot/SubPlot No: OLD : 846 ; NEW : 1933
Application Type: General Proposal	North: Plot No. - PARWATI DEVI
Project Type: Building Permission	South: Plot No. - NEW PLOT NO. 2045
Nature of Development: New	East: Road Width - 3.05
Location of Development Area: Old Area	West: Plot No. - 2045 , 2046
AREA DETAILS: SQ.MT.	
AREA OF PLOT (Minimum)	(A) 70.37
NET AREA OF PLOT(Gross Plot Area - Deduction from Gross Plot area)	(A-Deductions) 70.37
Deduction for Balance Plot Area(from Gross Plot Area)	
Common Plot	8.65
Total	8.65
BALANCE AREA OF PLOT(Net Plot Area - Recreational/Amenity space)	(A-Deductions) 61.72
PLOT AREA FOR COVERAGE(Net Plot Area)	(A-Deductions) 70.37
Plot Area for FAR (Net Plot Area + RoadWidening Area)	(A-Deductions) 70.37
COVERAGE CHECK	
Permissible Coverage area ( 70.00 % )	49.26
Proposed Coverage Area ( 58.90 % )	41.45
Total Prop. Coverage Area ( 58.9 % )	41.45
Balance coverage area ( 11.10 % )	7.81
FAR CHECK	
Perm. FAR Area ( 1.50 )	105.56
Total Perm. FAR area	105.56
Residential FAR	82.91
Proposed FAR Area	82.91
Total Proposed FAR Area	82.91
Consumed FAR (Factor)	1.18
Balance FAR Area	22.65
BUILT UP AREA CHECK	
Total Proposed BuiltUp Area	82.90
ARCHITECT (Regd)	RAJEEV RANJAN SINGH
ENGINEER (Regd)	
SUPERVISOR (Regd)	
OWNER (Regd)	SMT KAUSHALYA DEVI
DEVELOPMENT AUTHORITY LOCAL BODY	

COLOR INDEX

PLOT BOUNDARY	Black
ABUTTING ROAD	Red
PROPOSED CONSTRUCTION	Green
COMMON PLOT	Yellow
ROAD WIDENING AREA	Blue
EXISTING (To be retained)	Orange
EXISTING (To be demolished)	Purple

Buildingwise Floor FAR Details

Floor Name	Building Name A (A)		Total	
	Proposed Built Up Area (Sq.mt.)	Proposed FAR Area (Sq.mt.)	Total Proposed Built Up Area (Sq.mt.)	Total FAR Area (Sq.mt.)
Ground Floor	41.45	41.45	41.45	41.45
First Floor	41.45	41.45	41.45	41.45
Terrace Floor	0.00	0.00	0.00	0.00
Total:	82.90	82.90	82.90	82.90

FAR & Tenement Details (Table 4c-1)

Building	No. of Same Bldg	Total Built Up Area (Sq.mt.)	Proposed FAR Area (Sq.mt.)	Total FAR Area (Sq.mt.)	Total Consumed Additional FAR Area (Sq.mt.)	Tnmt (No.)
A (A)	1	82.90	82.90	82.90	82.90	01
Grand Total:	1	82.90	82.90	82.90	82.90	01

Building :A (A)

Floor Name	Total Built Up Area (Sq.mt.)	Proposed FAR Area (Sq.mt.)	Total FAR Area (Sq.mt.)	Total Consumed Additional FAR Area (Sq.mt.)	Tnmt (No.)
Ground Floor	41.45	41.45	41.45	41.45	01
First Floor	41.45	41.45	41.45	41.45	00
Terrace Floor	0.00	0.00	0.00	0.00	00
Total:	82.90	82.90	82.90	82.90	01
Total Number of Same Buildings	1				
Total:	82.90	82.90	82.90	82.90	01

LTP NAME AND SIGNATURE RAJEEV RANJAN SINGH MADA/ENG/0004/2019	STRUCTURAL ENG'S NAME AND SIGNATURE	BUILDER NAME AND SIGNATURE	DIGITAL SIGNATURE
---	-------------------------------------	----------------------------	-------------------

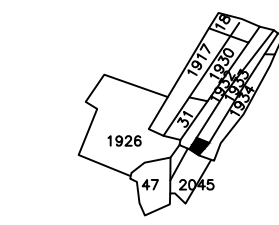
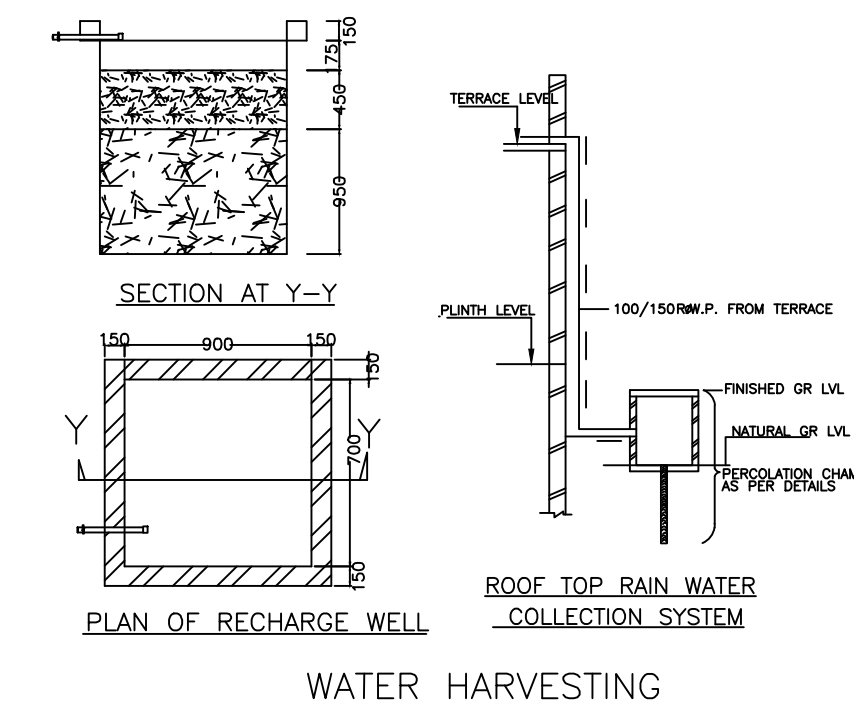
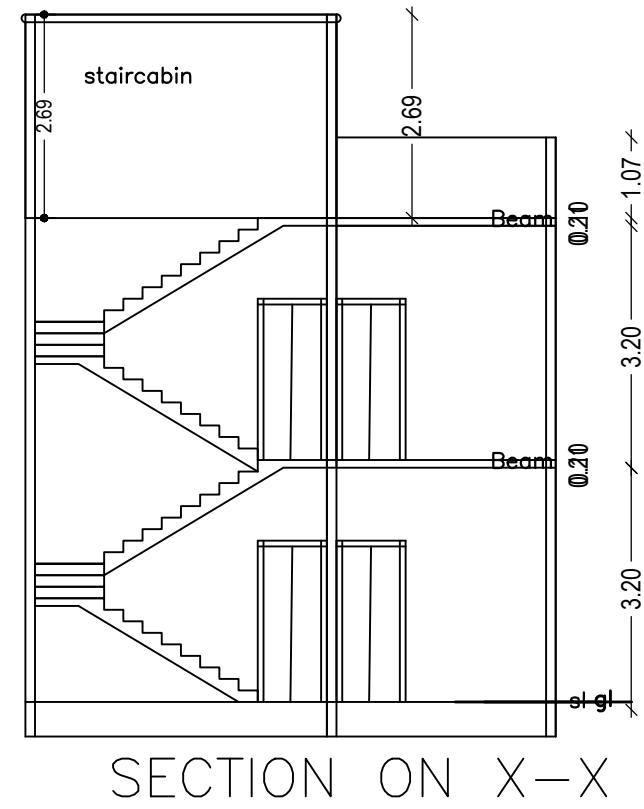
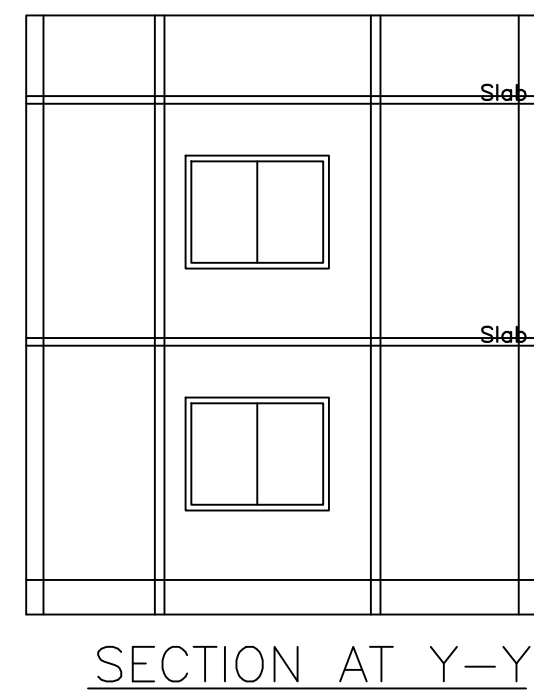
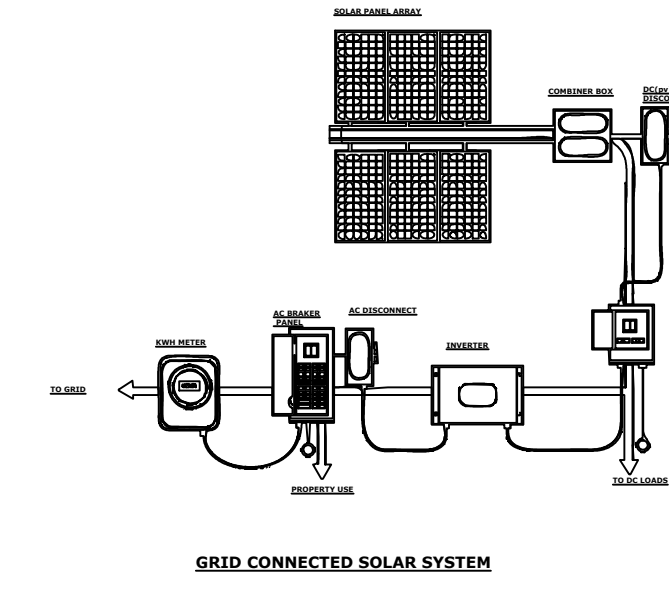
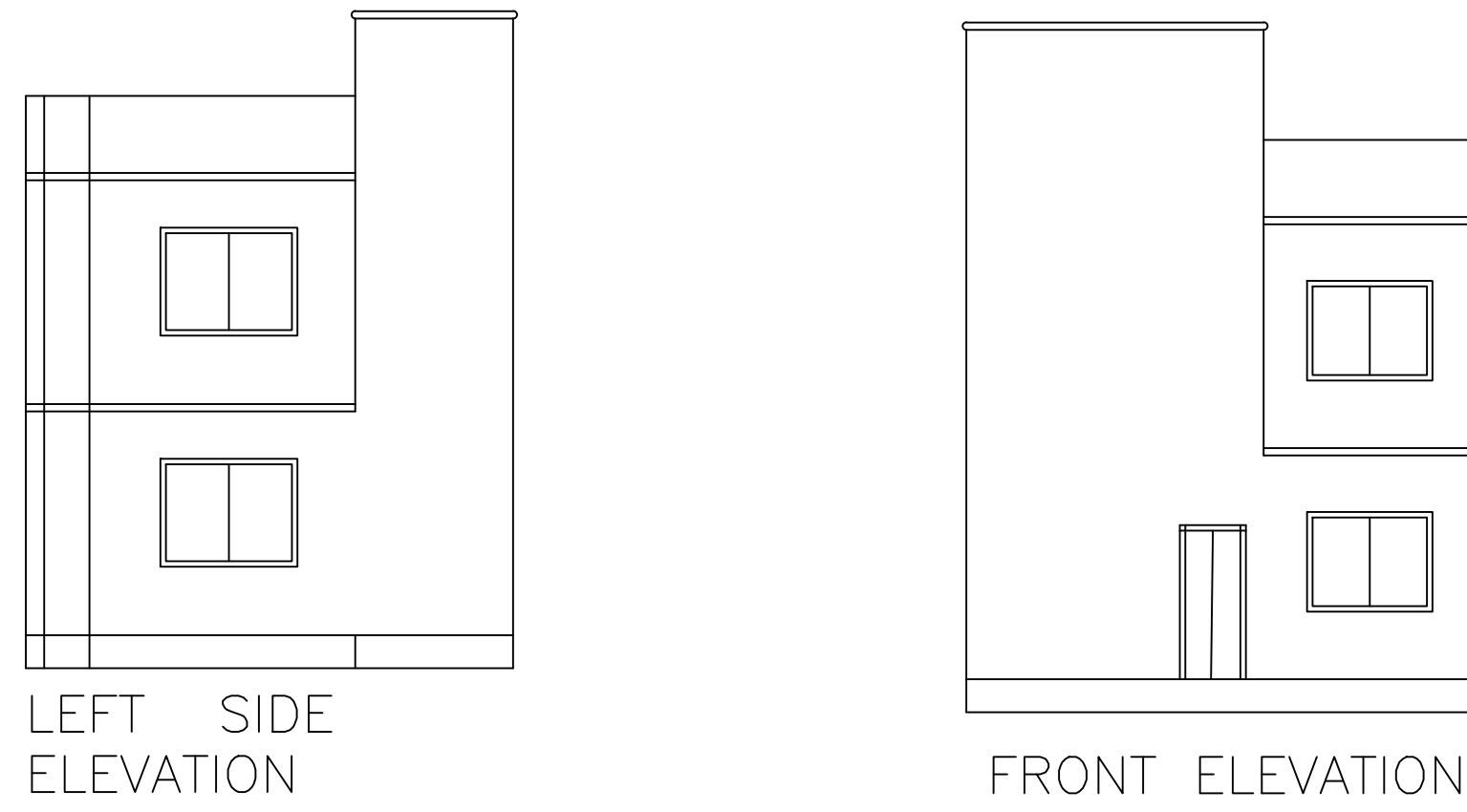
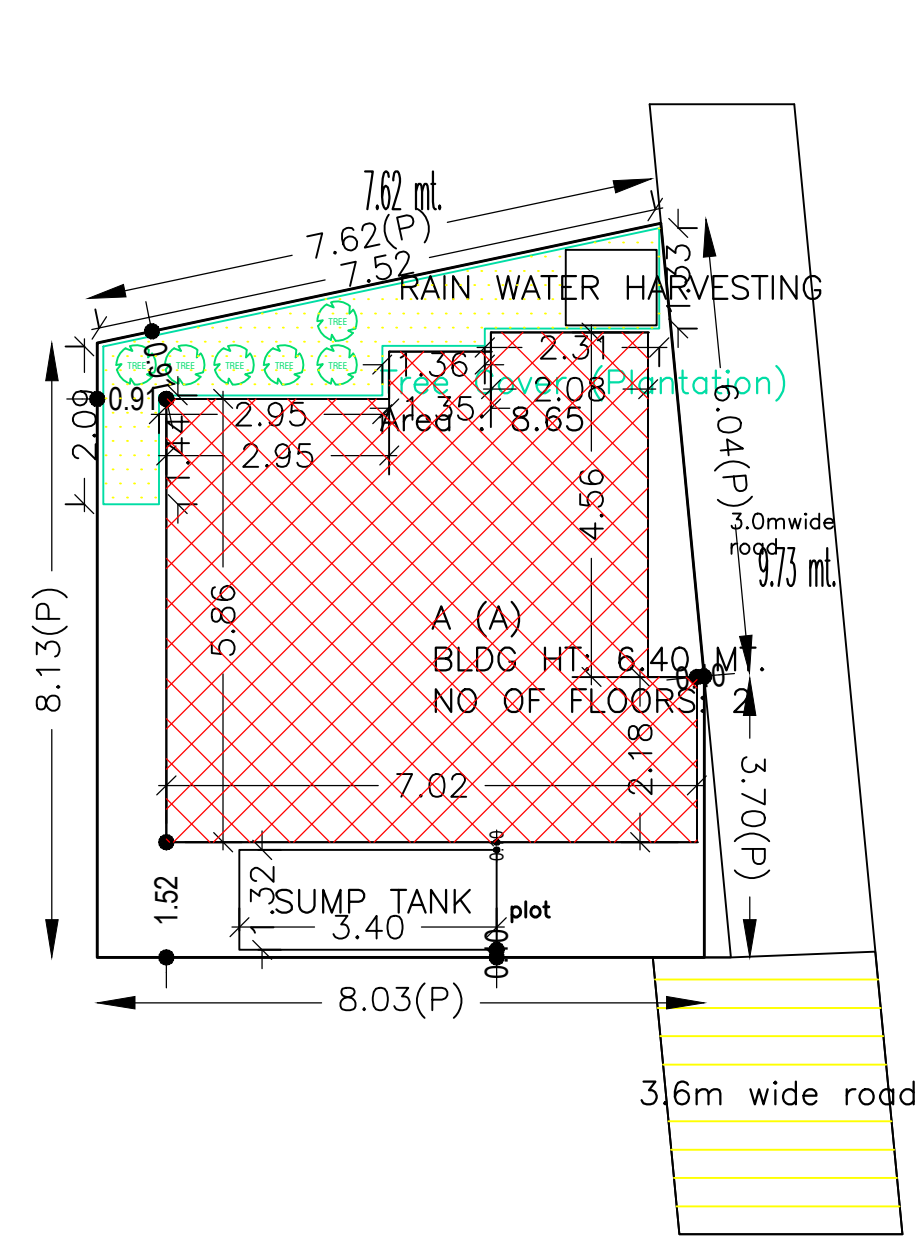

KEYPLAN

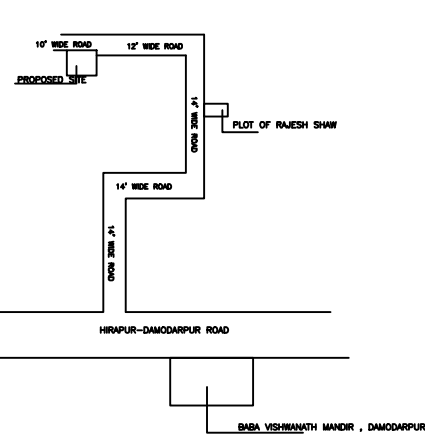

LOCATION

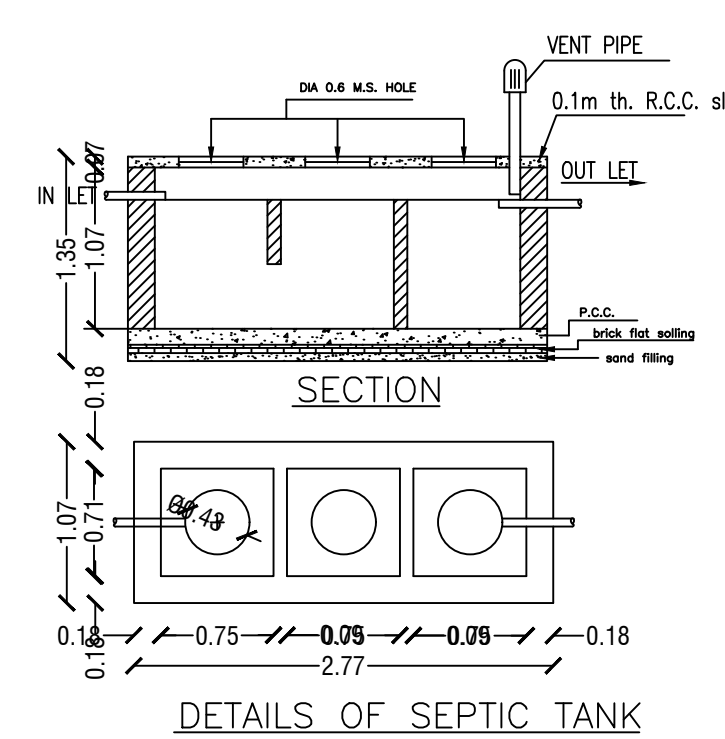
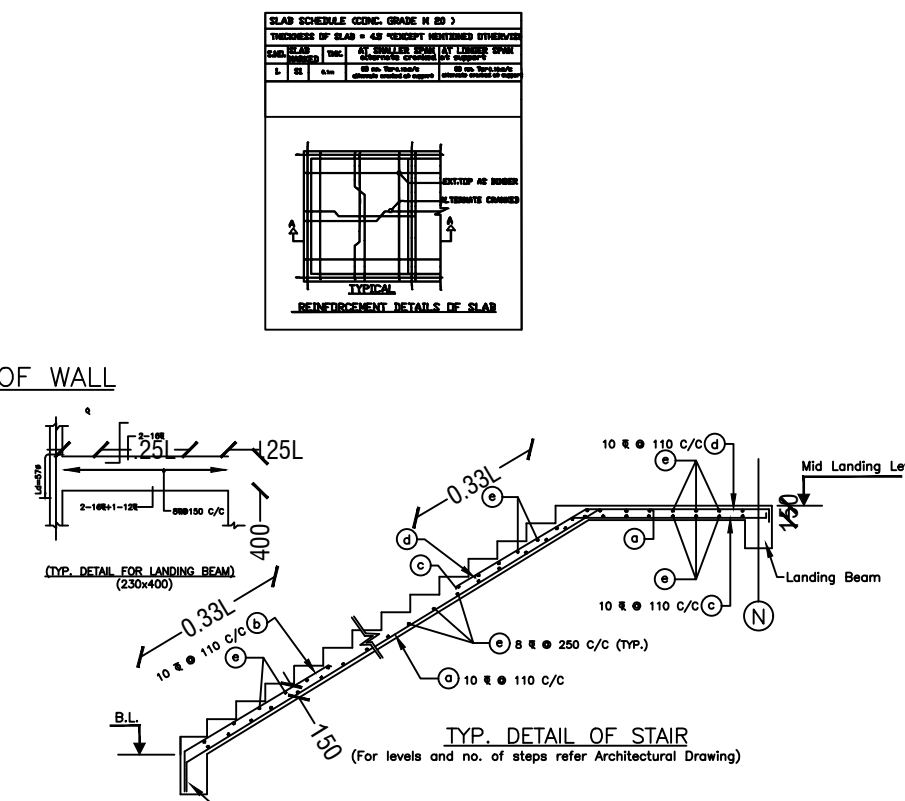
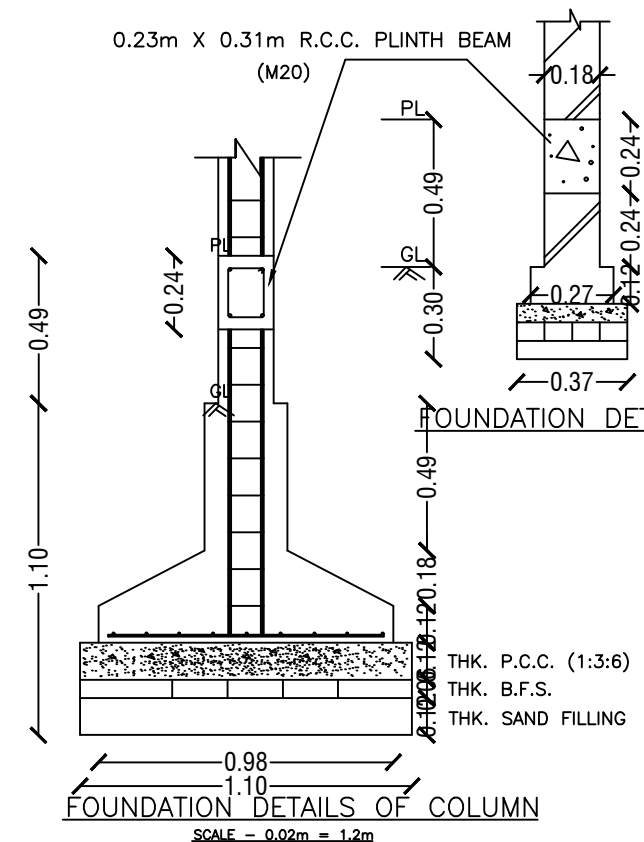
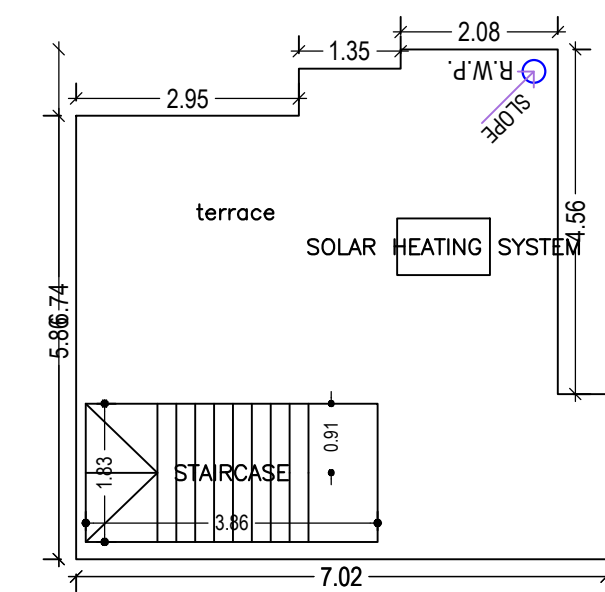
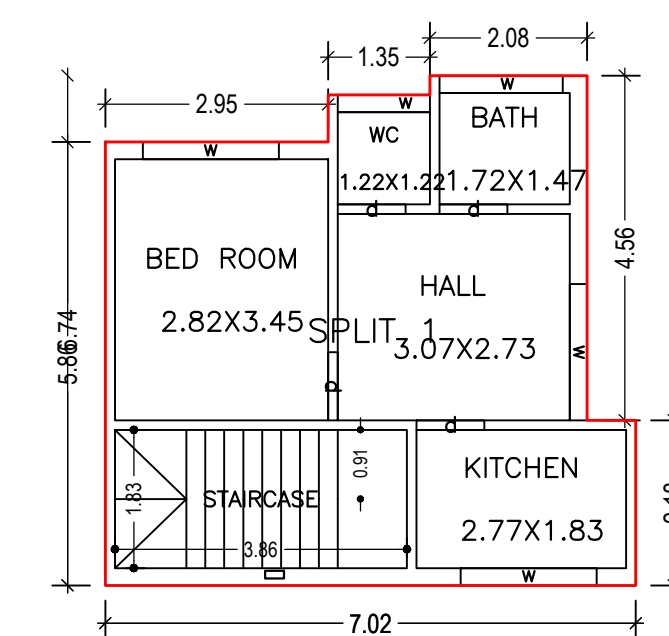
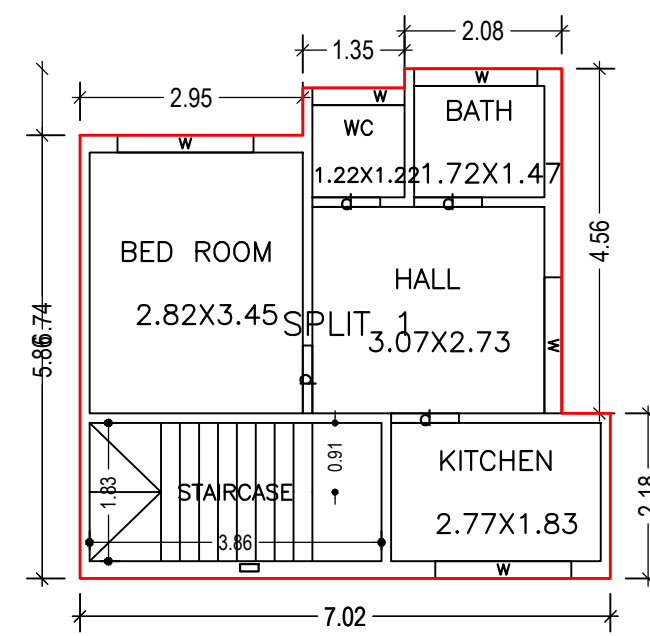

Building USE/SUBUSE Details

Building Name	Building Use	Building SubUse	Building Structure
A (A)	Residential	Residential Bldg/Apartment	Non-Highrise

SCHEDULE OF DOOR:

BUILDING NAME	NAME	LENGTH	HEIGHT	NOS
A (A)	d	0.90	2.10	08

SCHEDULE OF WINDOW/VENTILATION:

BUILDING NAME	NAME	LENGTH	HEIGHT	NOS
A (A)	w	1.22	1.20	02
A (A)	w	1.63	1.20	02
A (A)	w	1.80	1.20	06

UnitBUA Table for Building :A (A)

FLOOR	Name	UnitBUA Type	UnitBUA Area	Carpet Area	No. of Rooms	No. of Tenement
GROUND FLOOR PLAN	SPLIT 1	FLAT	82.91	82.86	5	1
FIRST FLOOR PLAN	SPLIT 1	FLAT	0.00	0.00	5	0
Total:	-	-	82.91	82.86	10	1

Proposal Basic Information	
Proposal File No.	MADA/BP/0057/2020
Owner Name	SMT KAUSHALYA DEVI
Khata No	OLD : 101 ; NEW : 243
Plot No	OLD : 846 ; NEW : 1933
Village Name	Damodarpur
Use	Residential
SubUse	Bungalow/ Dwelling / Non Apartment

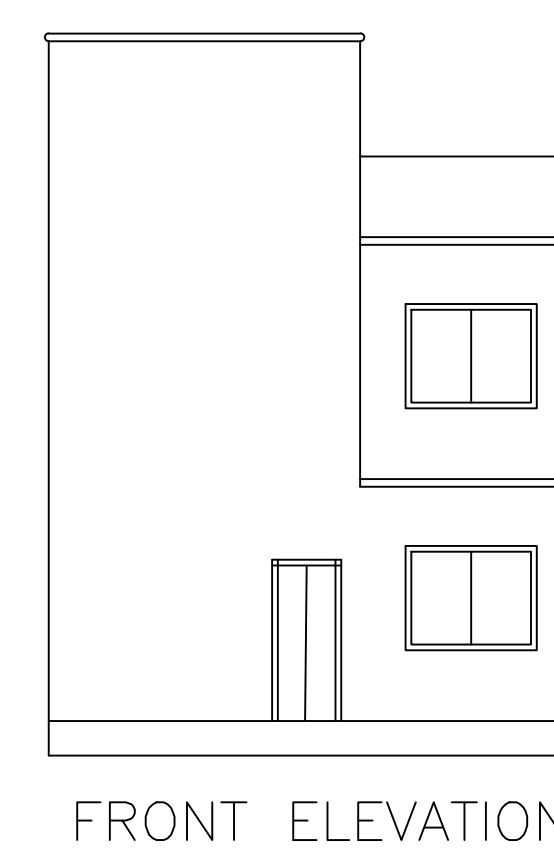
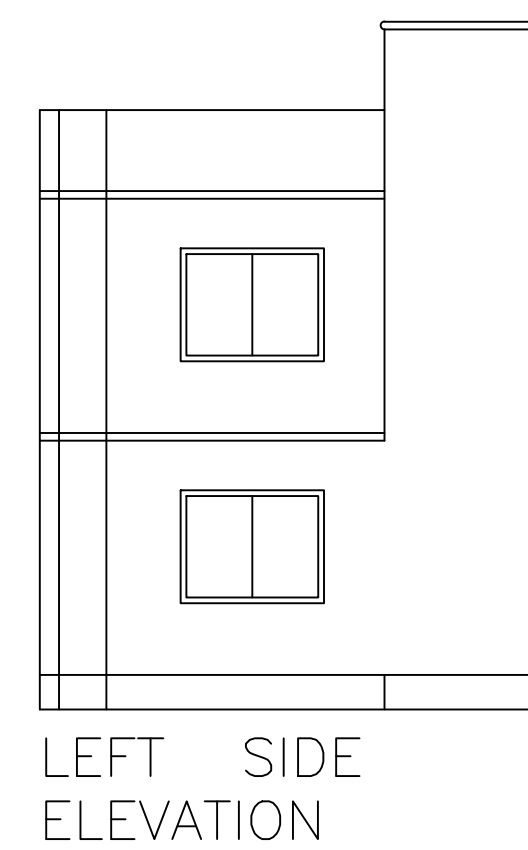
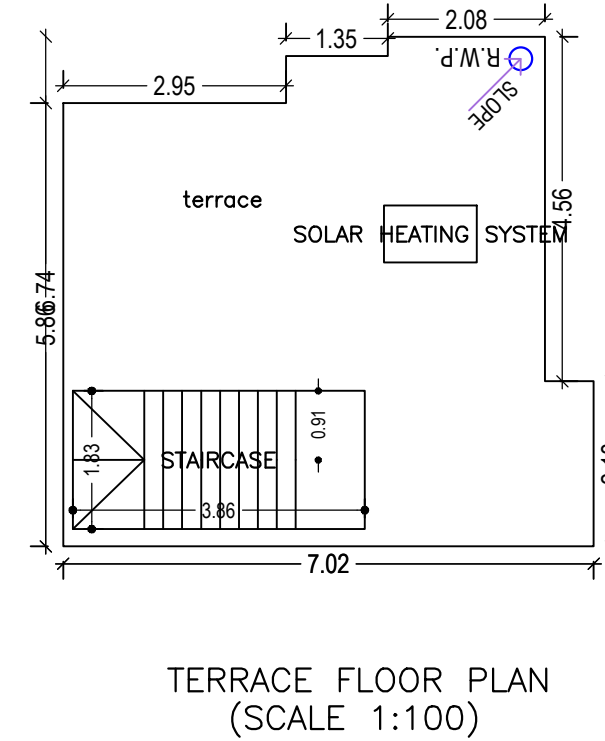
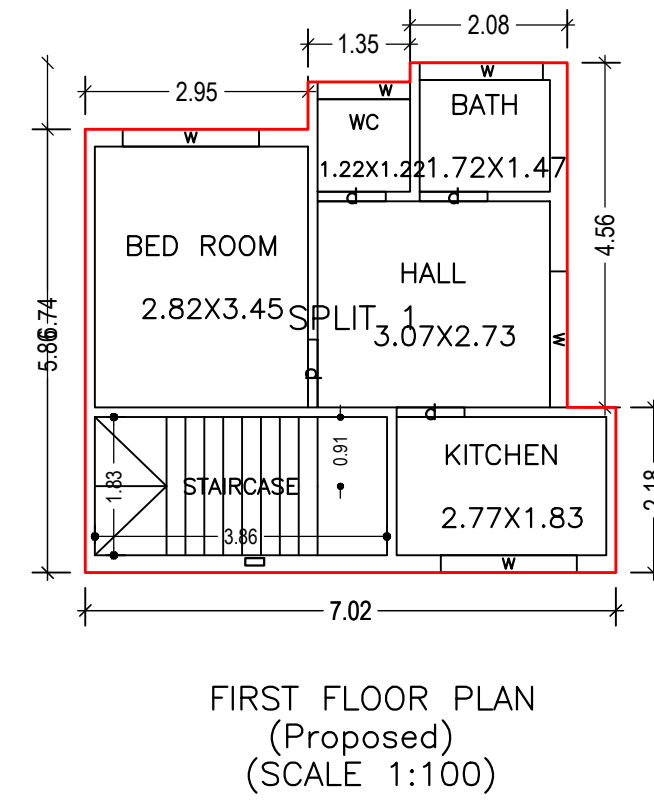
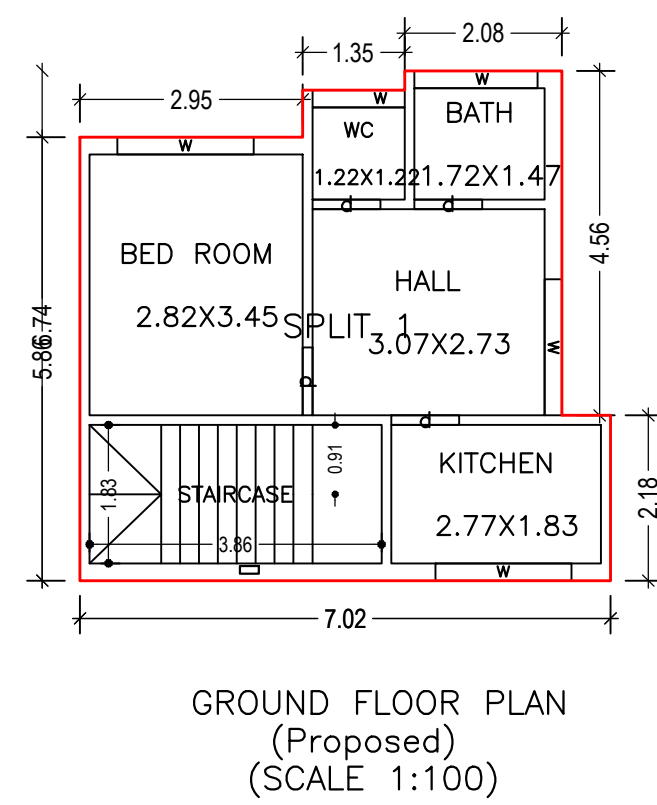
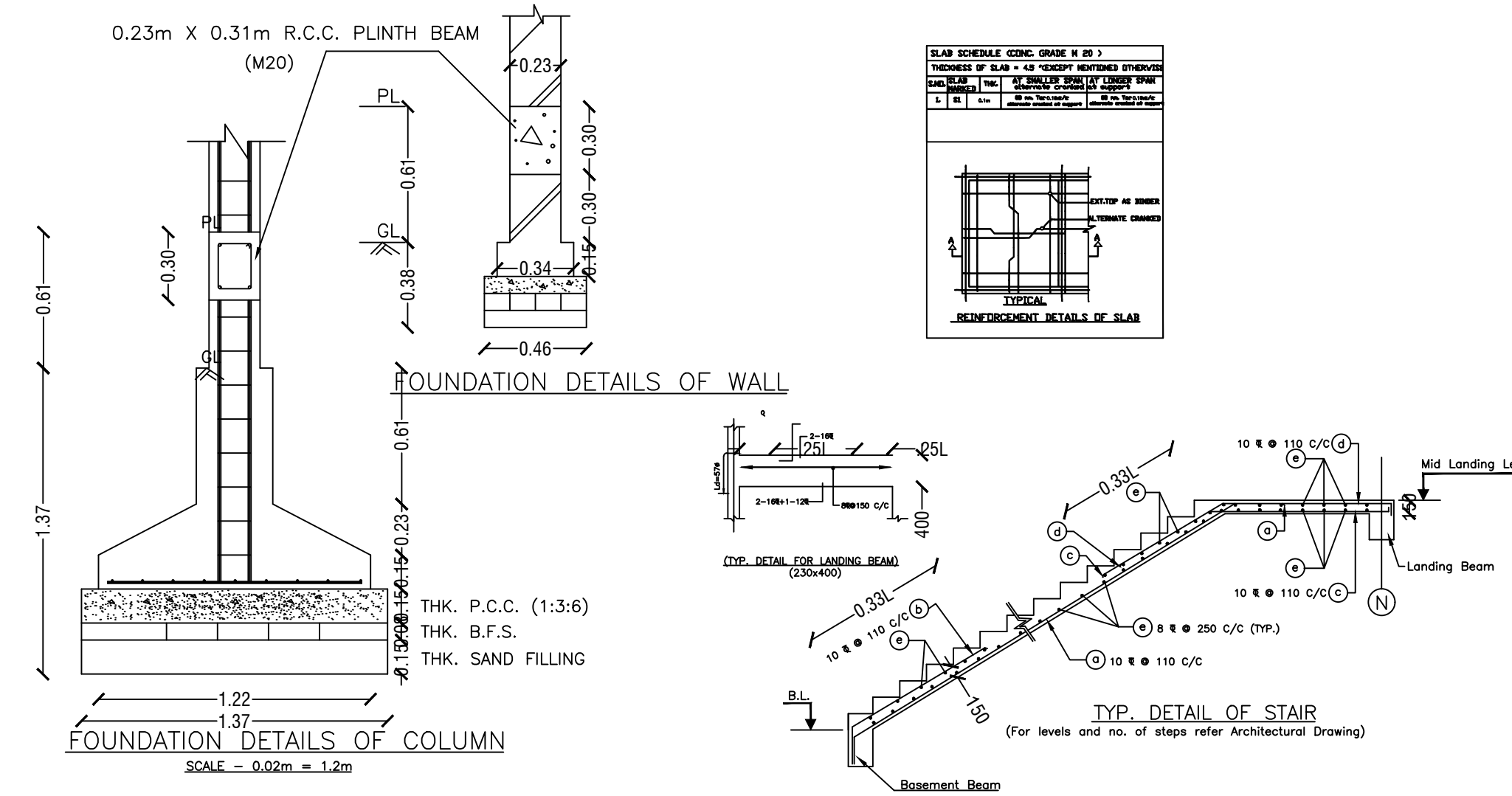
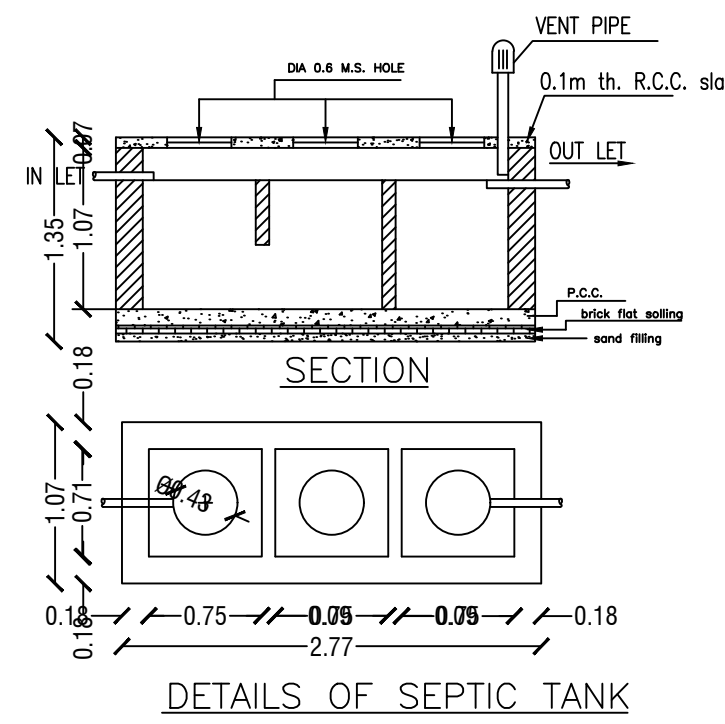
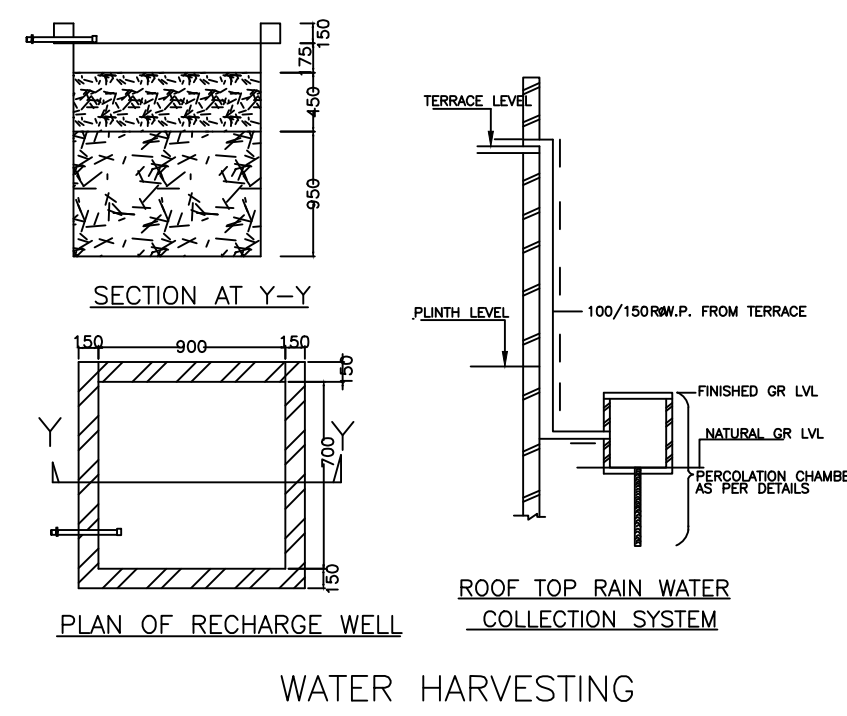
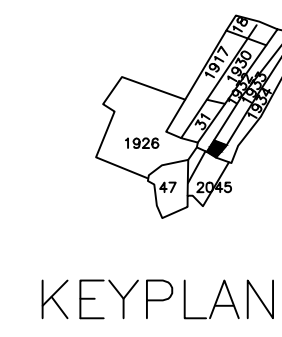
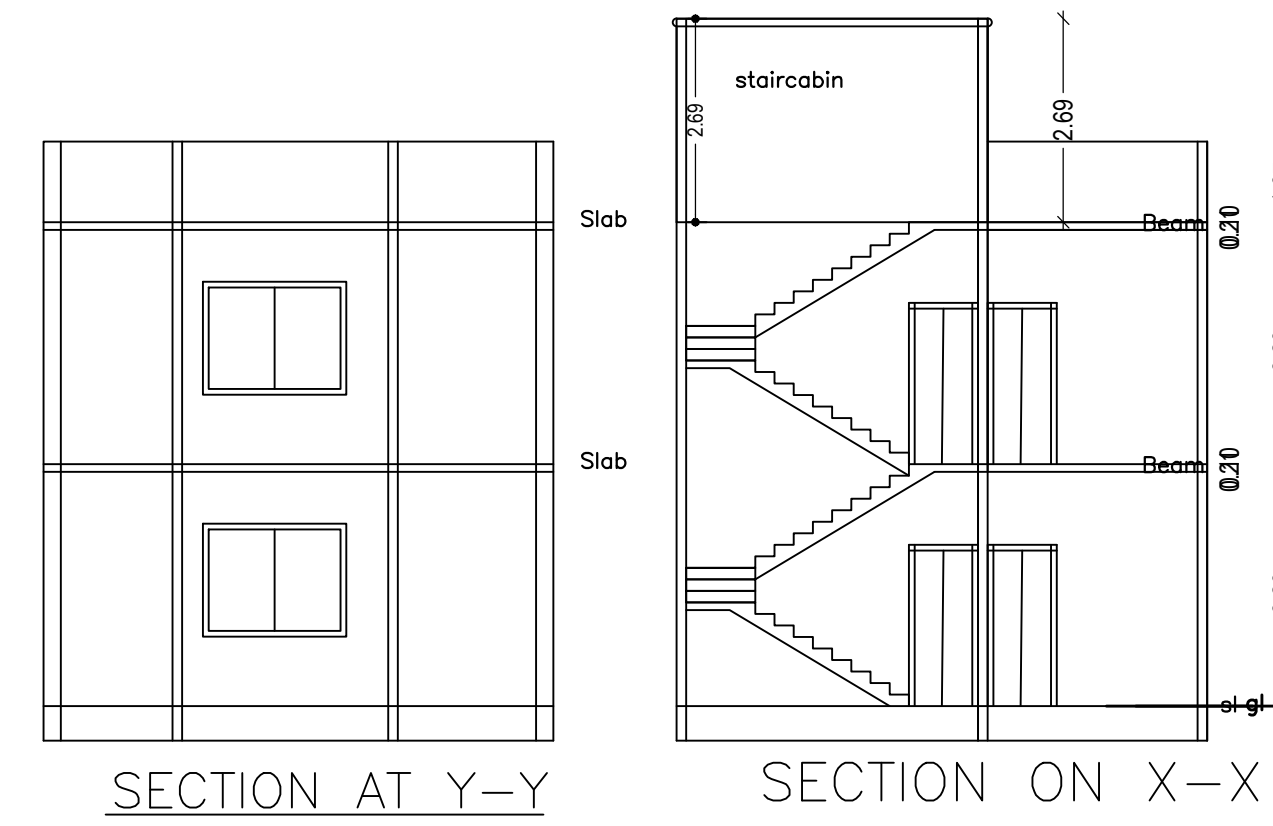
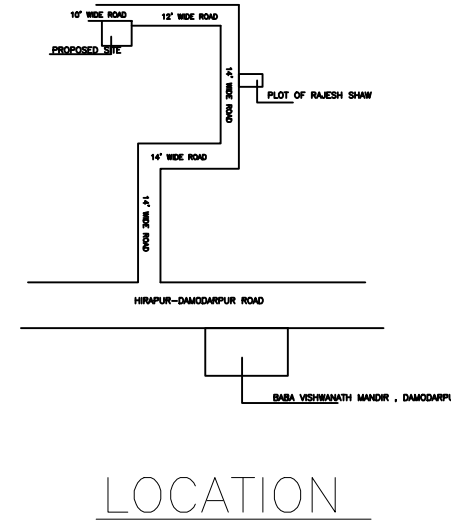
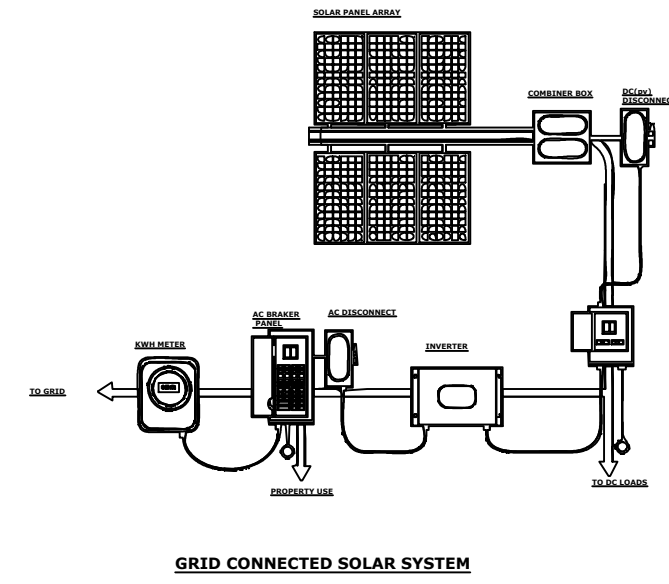

LTP NAME AND SIGNATURE	STRUCTURAL ENG'S NAME AND SIGNATURE	BUILDER NAME AND SIGNATURE	DIGITAL SIGNATURE
RAJEEV RANJAN SINGH MADA/ENG/0004/2019			