

ROOF TOP RAIN WATER COLLECTION SYSTEM

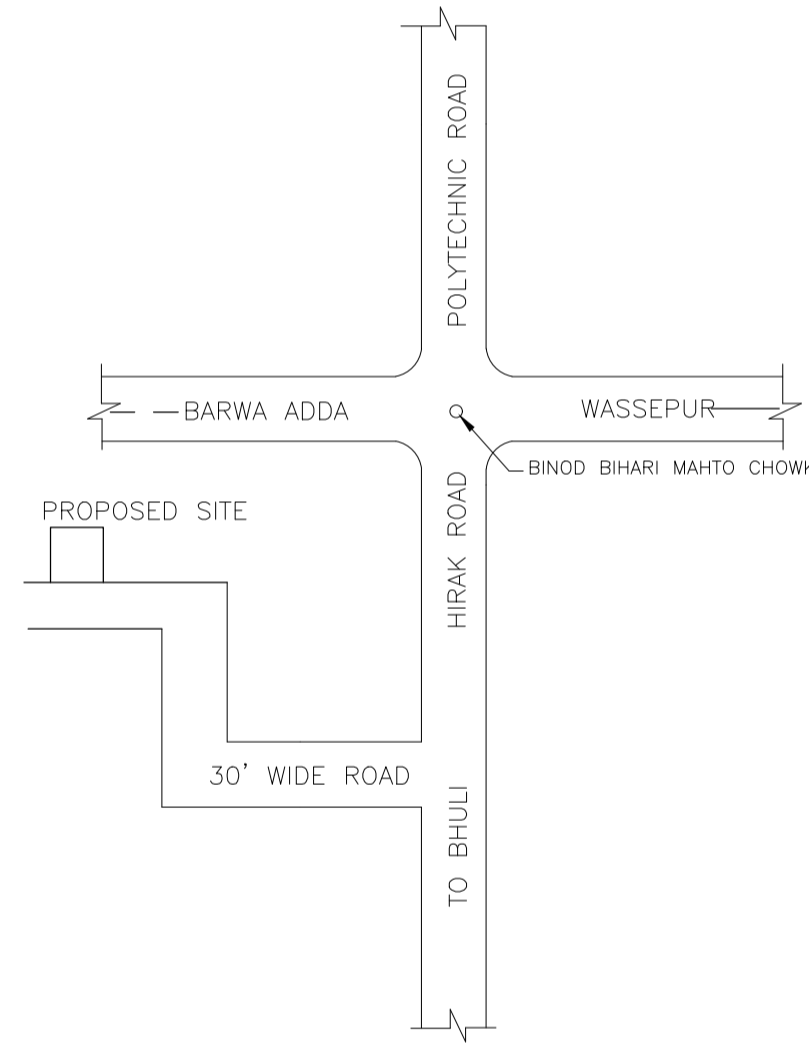

LOCATION PLAN NOT TO SCALE

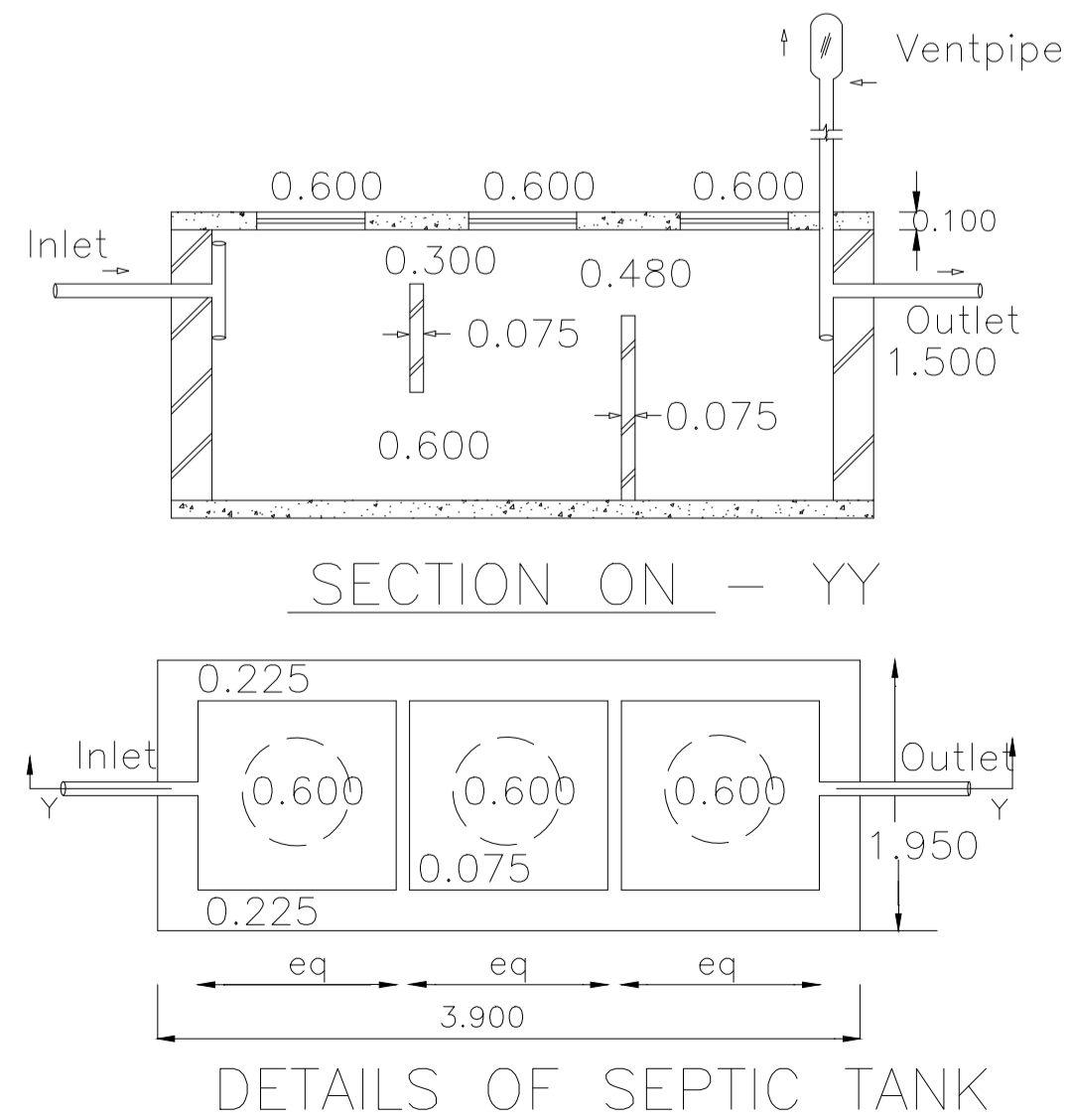

DETAILS OF SEPTIC TANK

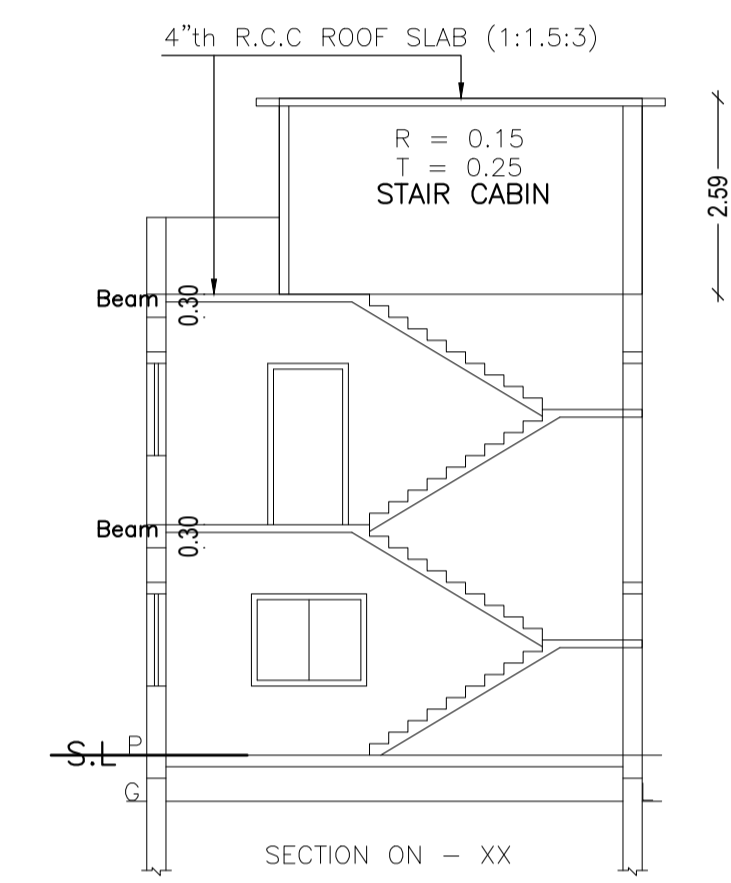

SECTION ON - XX

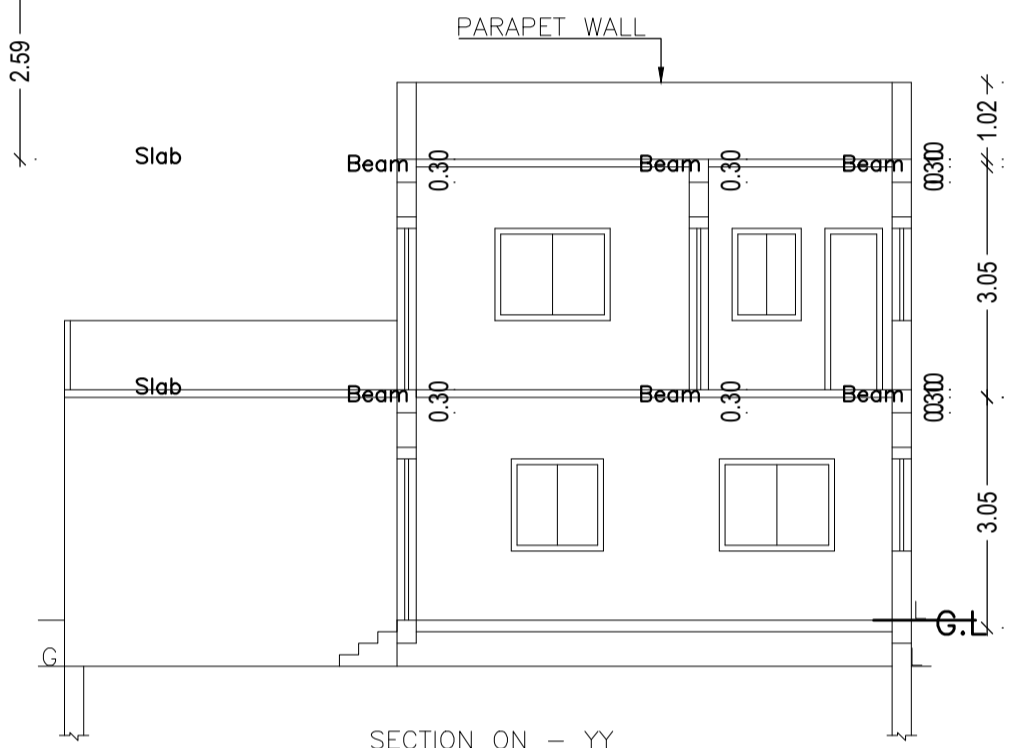

SECTION ON - YY

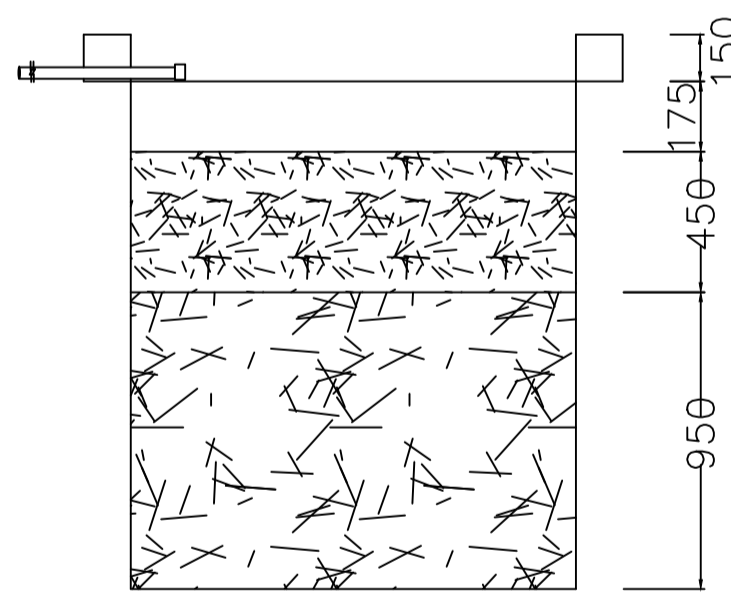

SECTION AT Y-Y

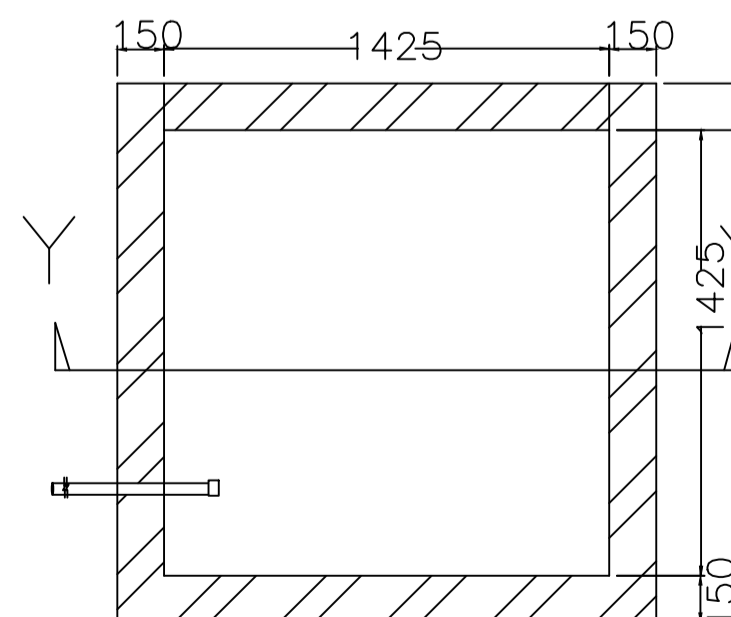

PLAN OF RECHARGE WELL

WATER HARVESTING

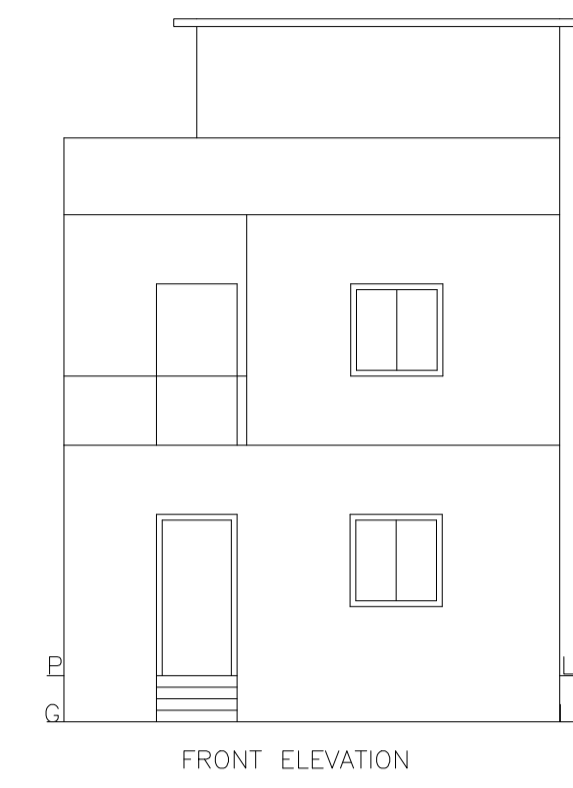

FRONT ELEVATION

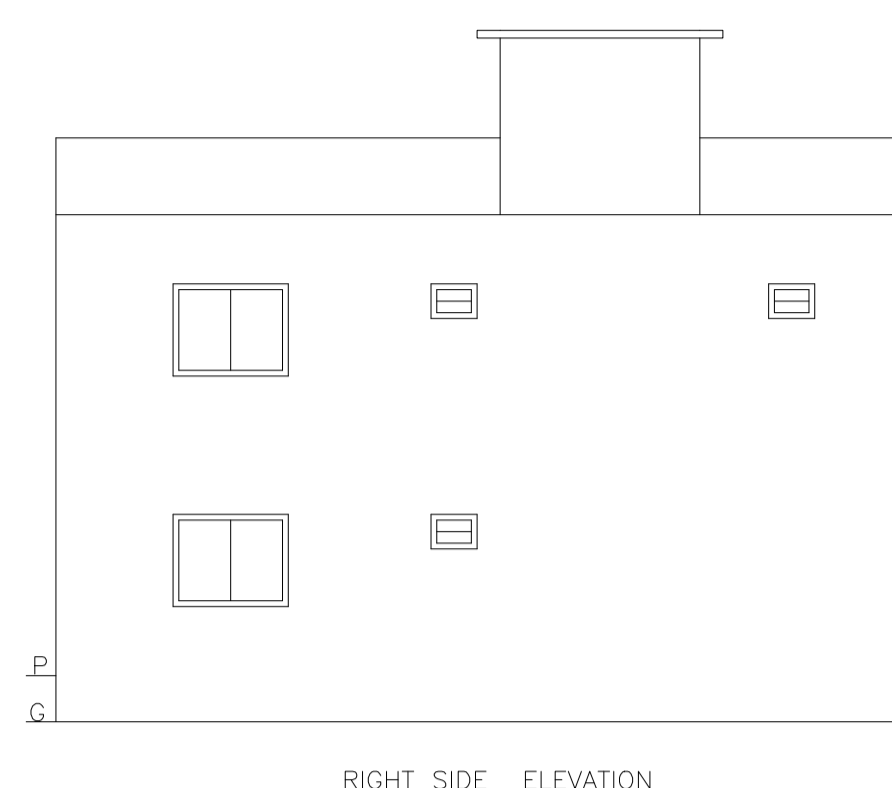

RIGHT SIDE ELEVATION

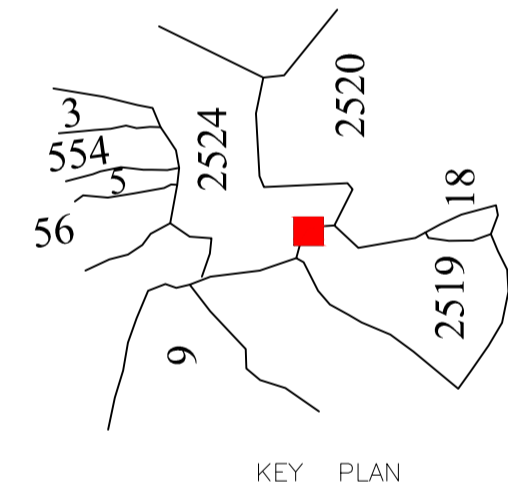

KEY PLAN

Proposal Basic Information

Proposal File No.	MADA/BP/0032/2020
Owner Name	SMT KRISHNA DEVI
Khata No	53, 35, NEW - 82, 247
Plot No	2519, 2524, NEW - 4052, 4015
Village Name	Bara Pichari
Use	Residential
SubUse	Bungalow/ Dwelling / Non Apartment

AREA STATEMENT MINERAL AUTHORITY	VERSION NO.: 1.0.46	SQ.MT.
PROJECT DETAIL:	VERSION DATE: 22/06/2020	
Region: JHARKHAND URBAN LOCAL BODIES	Plot Use: Residential	
District: DHANBAD	Plot SubUse: Bungalow/ Dwelling / Non Apartment	
Authority: MINERAL AREA DEVELOPMENT AUTHORITY	PlotNearby/ReligiousStructure: NA	
Inward No: MADA/BP/0032/2020	Plot/SubPlot No: 2519, 2524, NEW - 4052, 4015	
Application Type: General Proposal	North: Plot No. - PART OF PLOT NO - 2519 & 2524	
Project Type: Building Permission	South: Plot No. - PART OF PLOT NO - 2519 & 2524	
Nature of Development: New	East: Plot No. - PART OF PLOT NO - 2524	
Location of Development Area: Old Area	West: Road Width - 9.14 M WIDE ROAD.	
AREA OF PLOT (Minimum)	(A)	129.49
NET AREA OF PLOT(Gross Plot Area - Deduction from Gross Plot area)	(A-Deductions)	129.49
Deduction for Balance Plot Area(from Gross Plot Area)		
Common Plot		10.22
Total		10.22
BALANCE AREA OF PLOT(Net Plot Area - Recreational/Amenity space)	(A-Deductions)	119.27
PLOT AREA FOR COVERAGE(Net Plot Area)	(A-Deductions)	129.49
Plot Area for FAR (Net Plot Area + Road/Widening Area)	(A-Deductions)	129.49
COVERAGE CHECK		
Permissible Coverage area ( 70.00 % )		90.64
Proposed Coverage Area ( 55.94 % )		72.44
Total Prop. Coverage Area ( 55.94 % )		72.44
Balance coverage area ( 14.05 % )		18.20
FAR CHECK		
Perm. FAR Area ( 2.50 )		323.73
Total Perm. FAR area		323.73
Residential FAR		134.63
Proposed FAR Area		134.63
Total Proposed FAR Area		134.63
Consumed FAR (Factor)		1.04
Balance FAR Area		189.10
BUILT UP AREA CHECK		
Total Proposed BuiltUp Area		134.63
ARCHITECT (Regd)	AMARENDRA KUMAR	
ENGINEER (Regd)		
SUPERVISOR (Regd)		
OWNER (Regd)	SMT KRISHNA DEVI	
DEVELOPMENT AUTHORITY		LOCAL BODY

COLOR INDEX

PLOT BOUNDARY	Black
ABUTTING ROAD	Green
PROPOSED CONSTRUCTION	Red
COMMON PLOT	Yellow
ROAD WIDENING AREA	Blue
EXISTING (To be retained)	Light Blue
EXISTING (To be demolished)	Dark Blue

Buildingwise Floor FAR Details

Floor Name	Building Name A (A)		Total	
	Proposed Built Up Area (Sq.mt.)	Proposed FAR Area (Sq.mt.)	Total Proposed Built Up Area (Sq.mt.)	Total FAR Area (Sq.mt.)
Ground Floor	72.44	72.44	72.44	72.44
First Floor	62.19	62.19	62.19	62.19
Terrace Floor	0.00	0.00	0.00	0.00
Total :	134.63	134.63	134.63	134.63

Building USE/SUBUSE Details

Building Name	Building Use	Building SubUse	Building Structure
A (A)	Residential	Bungalow/ Dwelling / Non Apartment	Non-Highrise

SCHEDULE OF DOOR:

BUILDING NAME	NAME	LENGTH	HEIGHT	NOS
A (A)	D	0.58	2.10	01
A (A)	D	0.76	2.10	04
A (A)	D	0.82	2.10	01
A (A)	D	0.90	2.10	01
A (A)	D	1.07	2.10	05

SCHEDULE OF WINDOW/VENTILATION:

BUILDING NAME	NAME	LENGTH	HEIGHT	NOS
A (A)	W	0.61	1.20	03
A (A)	W	0.91	1.20	02
A (A)	W	1.22	1.20	03
A (A)	W	1.52	1.20	06

Building :A (A)

Floor Name	Total Built Up Area (Sq.mt.)	Proposed FAR Area (Sq.mt.)	Total FAR Area (Sq.mt.)	Total Consumed Additional FAR Area (Sq.mt.)	Tnmt (No.)
Ground Floor	72.44	72.44	72.44	72.44	01
First Floor	62.19	62.19	62.19	62.19	00
Terrace Floor	0.00	0.00	0.00	0.00	00
Total :	134.63	134.63	134.63	134.63	01
Total Number of Same Buildings :	1				
Total :	134.63	134.63	134.63	134.63	01

UnitBUA Table for Building :A (A)

FLOOR	Name	UnitBUA Type	UnitBUA Area (Sq.mt.)	Carpet Area (Sq.mt.)	No. of Rooms	No. of Tenement
GROUND FLOOR PLAN	SPLIT A	FLAT	134.63	134.43	5	1
FIRST FLOOR PLAN	SPLIT A	FLAT	0.00	0.00	6	0
Total:	-	-	134.63	134.43	11	1

FAR & Tenement Details (Table 4c-1)

Building	No. of Same Bldg	Total Built Up Area (Sq.mt.)	Proposed FAR Area (Sq.mt.)	Total FAR Area (Sq.mt.)	Total Consumed Additional FAR Area (Sq.mt.)	Tnmt (No.)
A (A)	1	134.63	134.63	134.63	134.63	01
Grand Total :	1	134.63	134.63	134.63	134.63	01

LTP NAME AND SIGNATURE AMARENDRA KUMAR MADA/ENG/0008/2019	STRUCTURAL ENG'S NAME AND SIGNATURE	BUILDER NAME AND SIGNATURE	DIGITAL SIGNATURE
---	-------------------------------------	----------------------------	-------------------

Proposal Basic Information

Proposal File No.	MADA/BP/0032/2020
Owner Name	SMT KRISHNA DEVI
Khata No	53, 35, NEW - 82, 247
Plot No	2519, 2524, NEW - 4052, 4015
Village Name	Bara Pichari
Use	Residential
SubUse	Bungalow/ Dwelling / Non Apartment

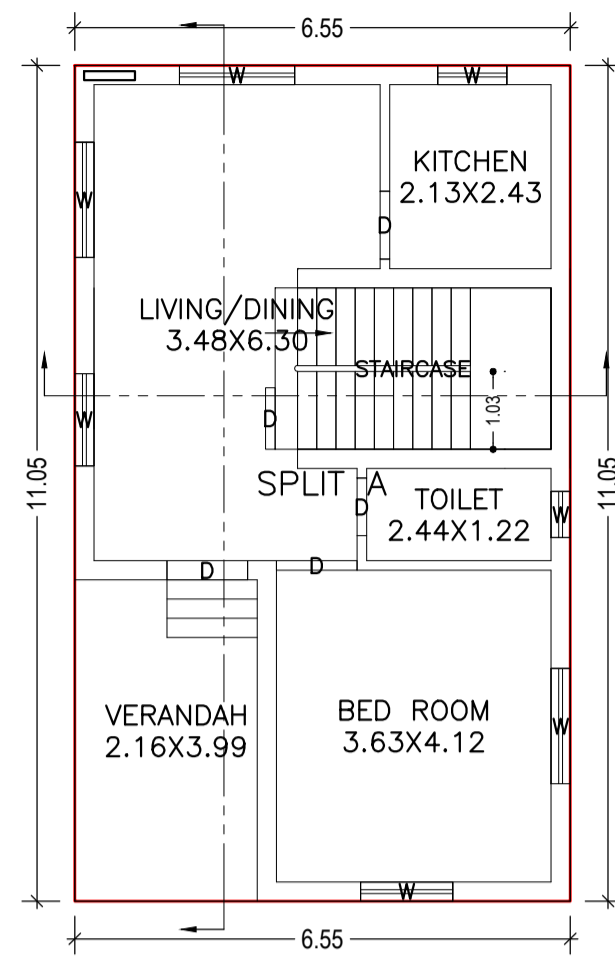

GROUND FLOOR PLAN (Proposed) (SCALE 1:100)

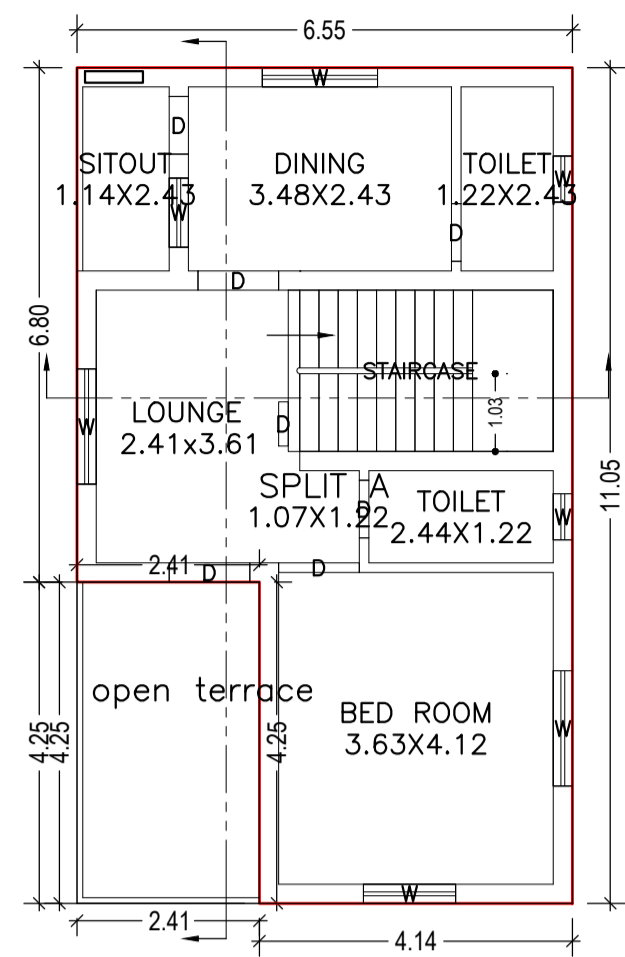

FIRST FLOOR PLAN (Proposed) (SCALE 1:100)

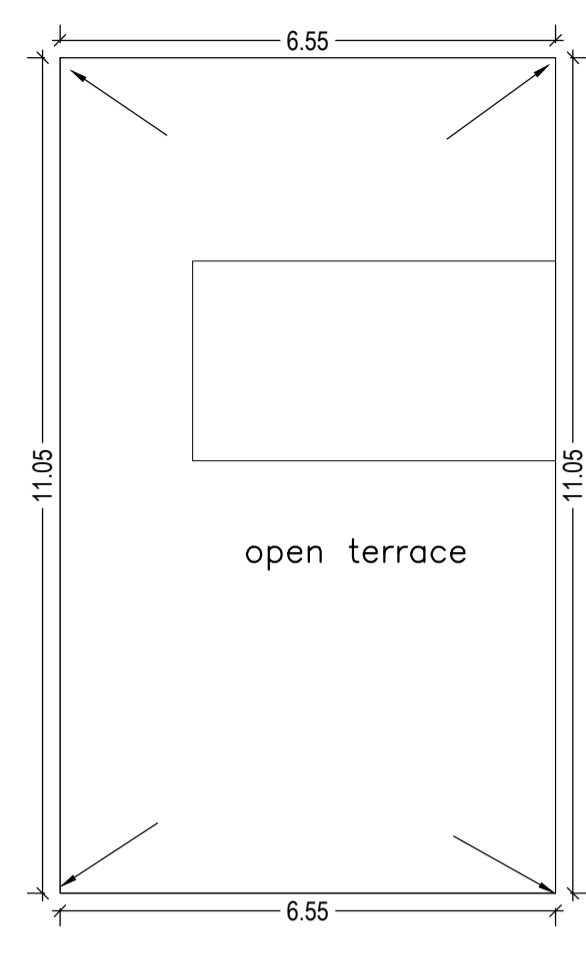

TERRACE FLOOR PLAN (SCALE 1:100)

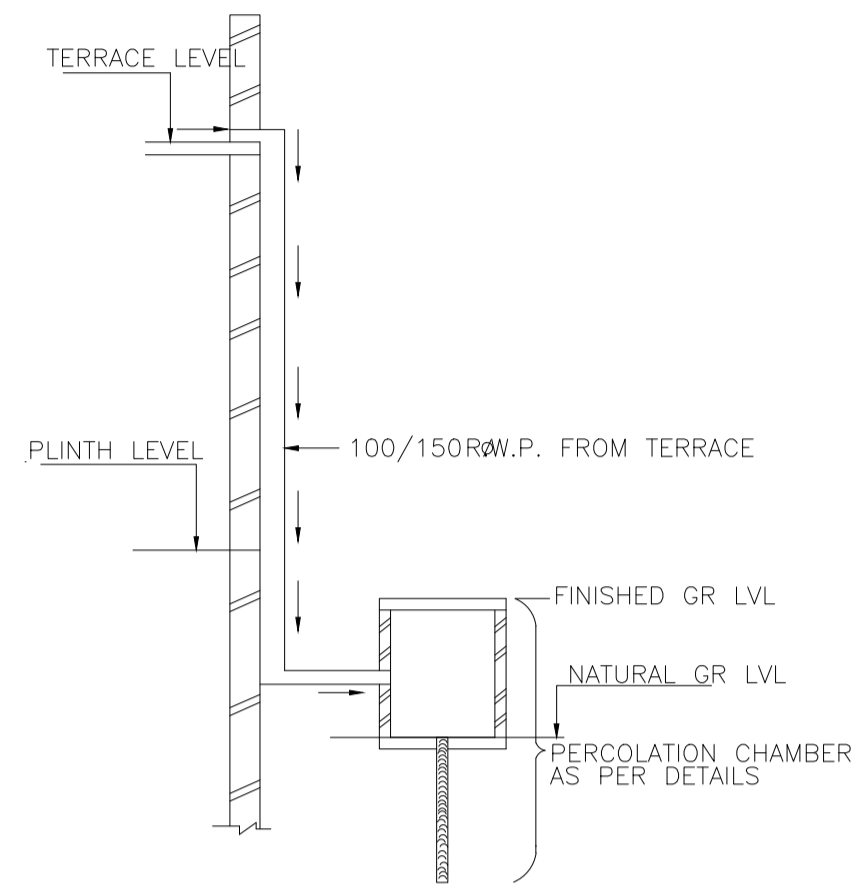

ROOF TOP RAIN WATER COLLECTION SYSTEM

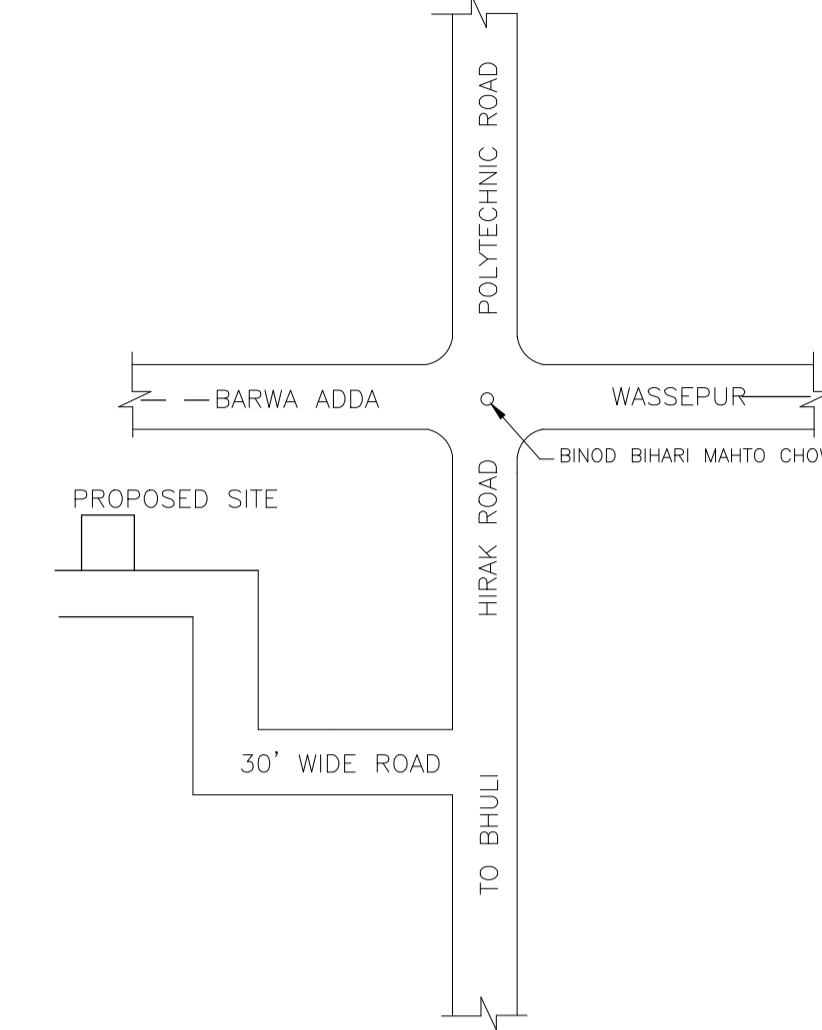

LOCATION PLAN NOT TO SCALE

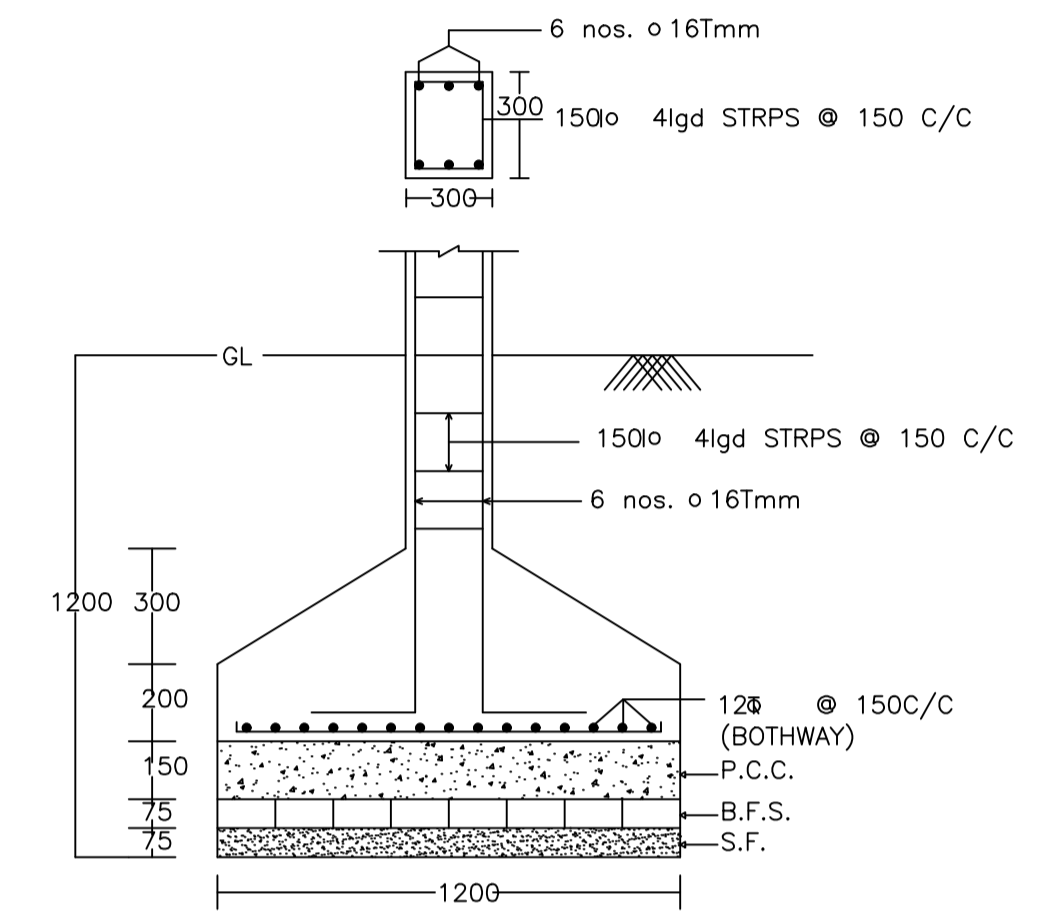

SECTION

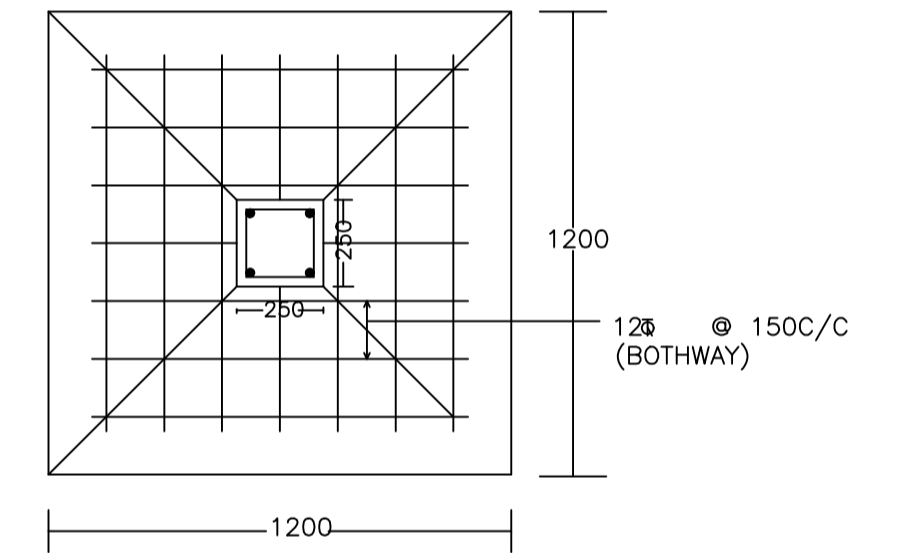

PLAN

DETAIL OF COLUMNS

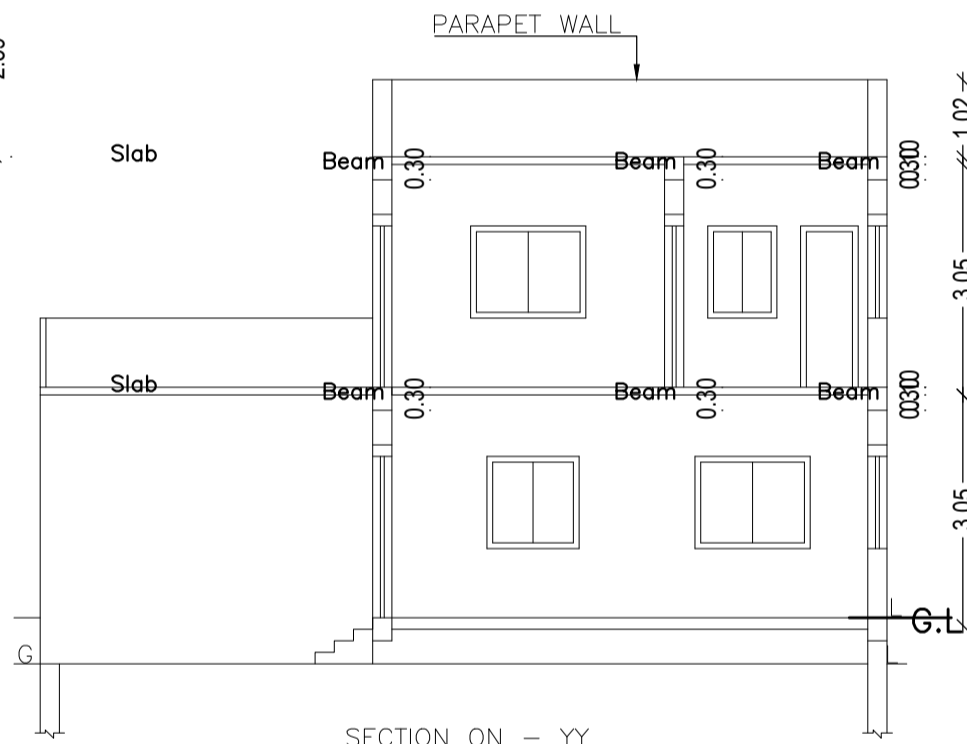
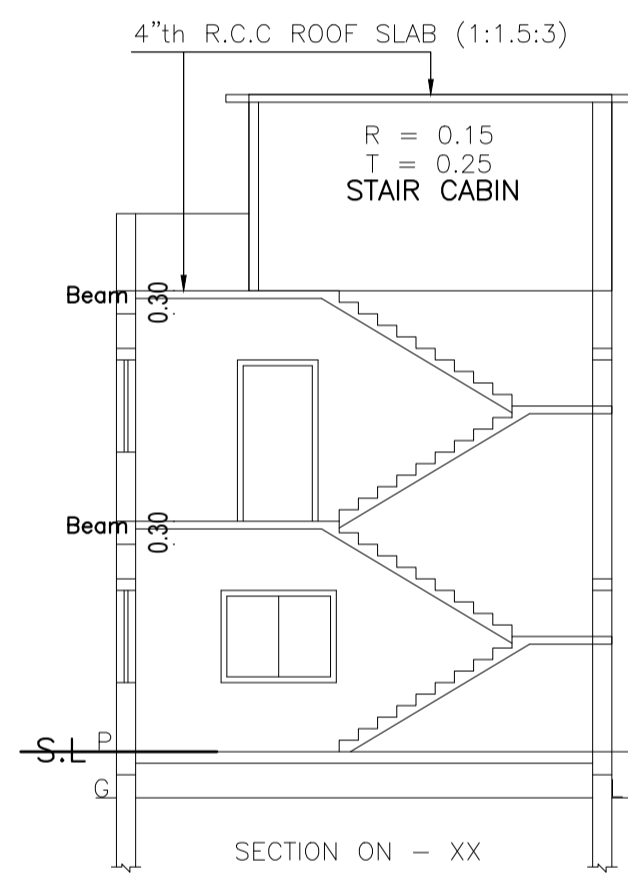

SECTION ON - XX

SECTION ON - YY

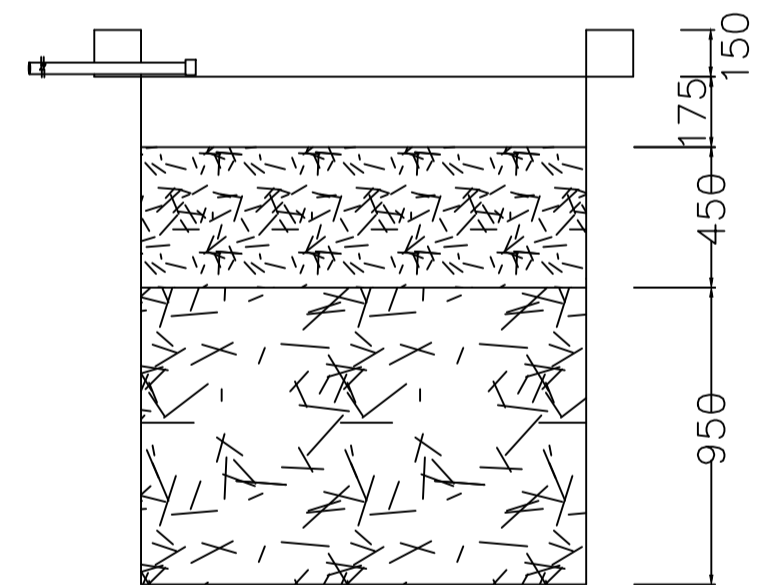

SECTION AT Y-Y

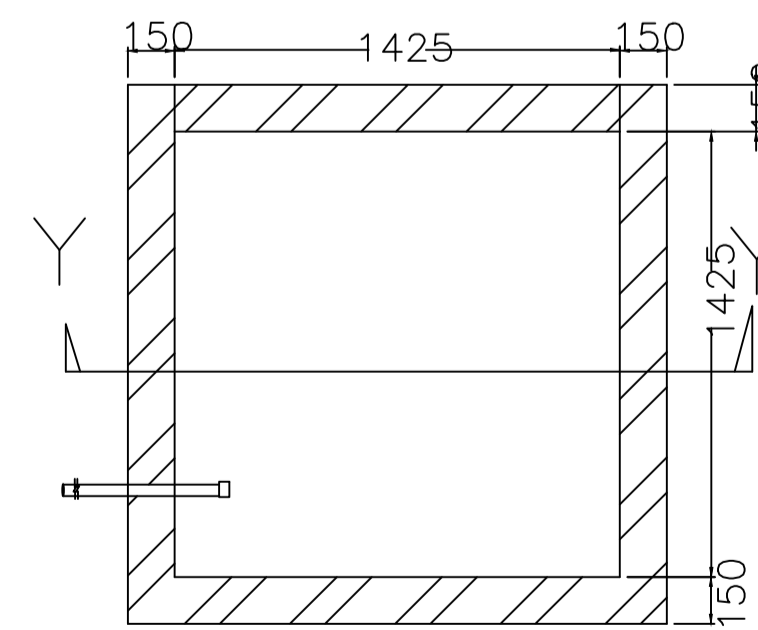

PLAN OF RECHARGE WELL

WATER HARVESTING

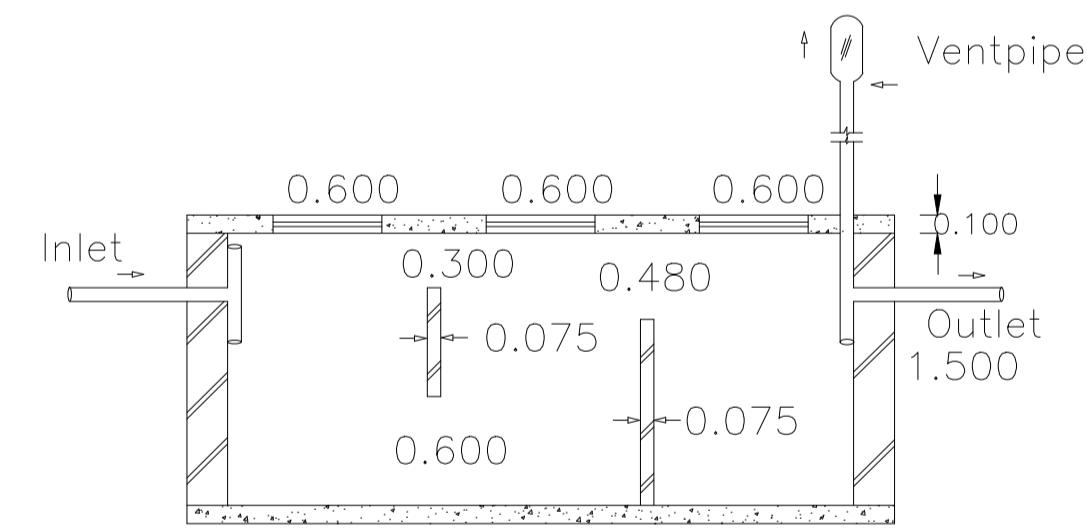

SECTION ON - YY

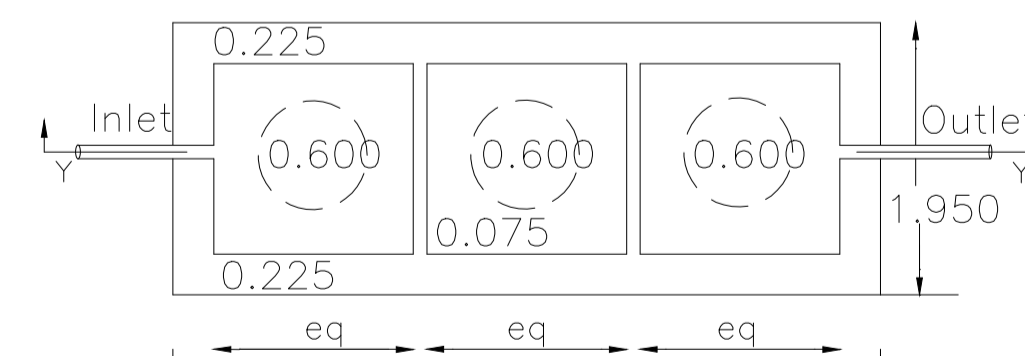

DETAILS OF SEPTIC TANK

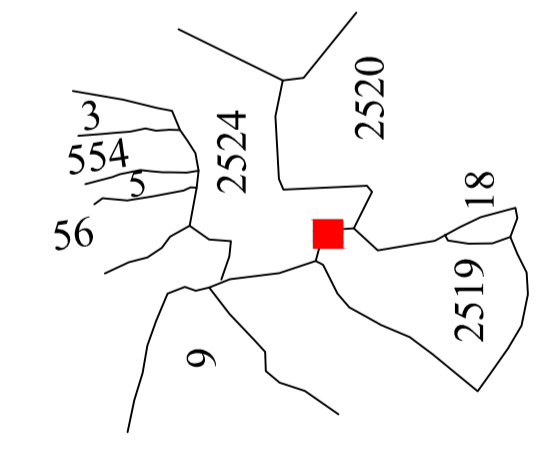

KEY PLAN

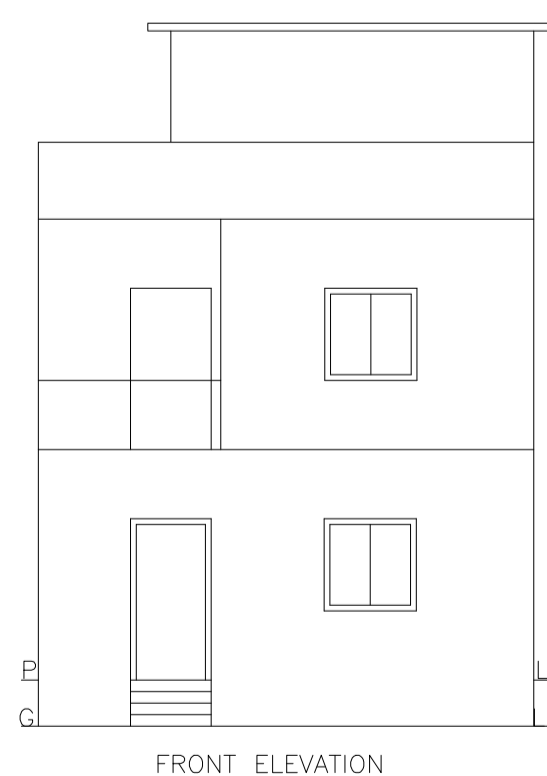

FRONT ELEVATION

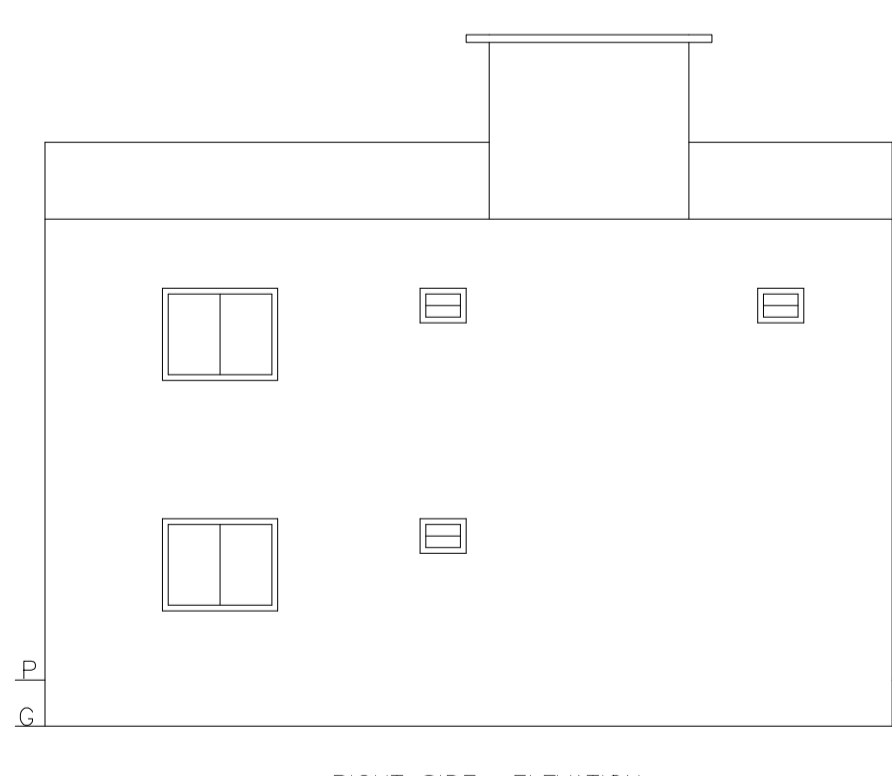

RIGHT SIDE ELEVATION

LTP NAME AND SIGNATURE	STRUCTURAL ENG'S NAME AND SIGNATURE	BUILDER NAME AND SIGNATURE	DIGITAL SIGNATURE
AMARENDRA KUMAR MADA/ENG/0008/2019			