

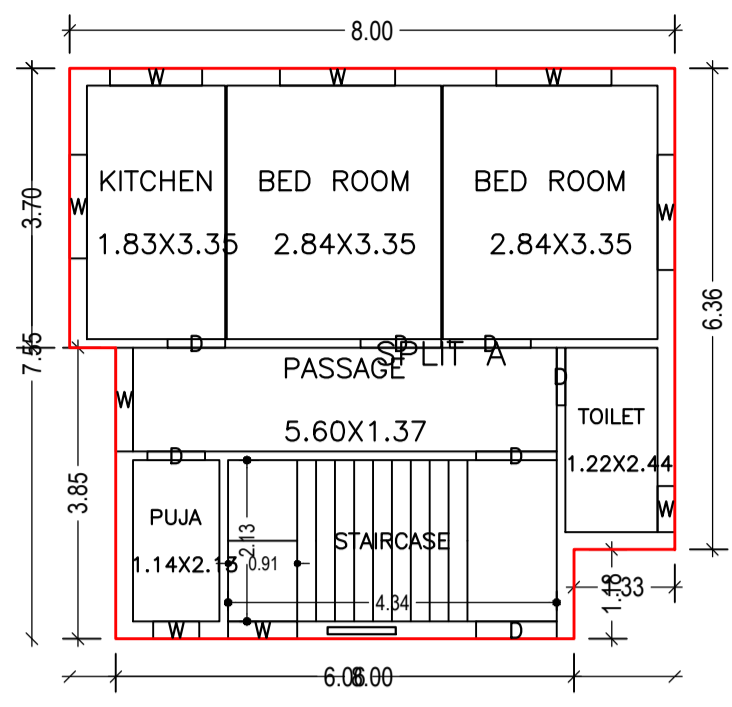

Proposal Basic Information	
Proposal File No.	MADA/BP/0143/2020
Owner Name	SMT ANU KUMARI
Khata No	OLD-82,NEW-566
Plot No	OLD-1418,NEW-1181
Village Name	Govindpur
Use	Residential
SubUse	Semidetached

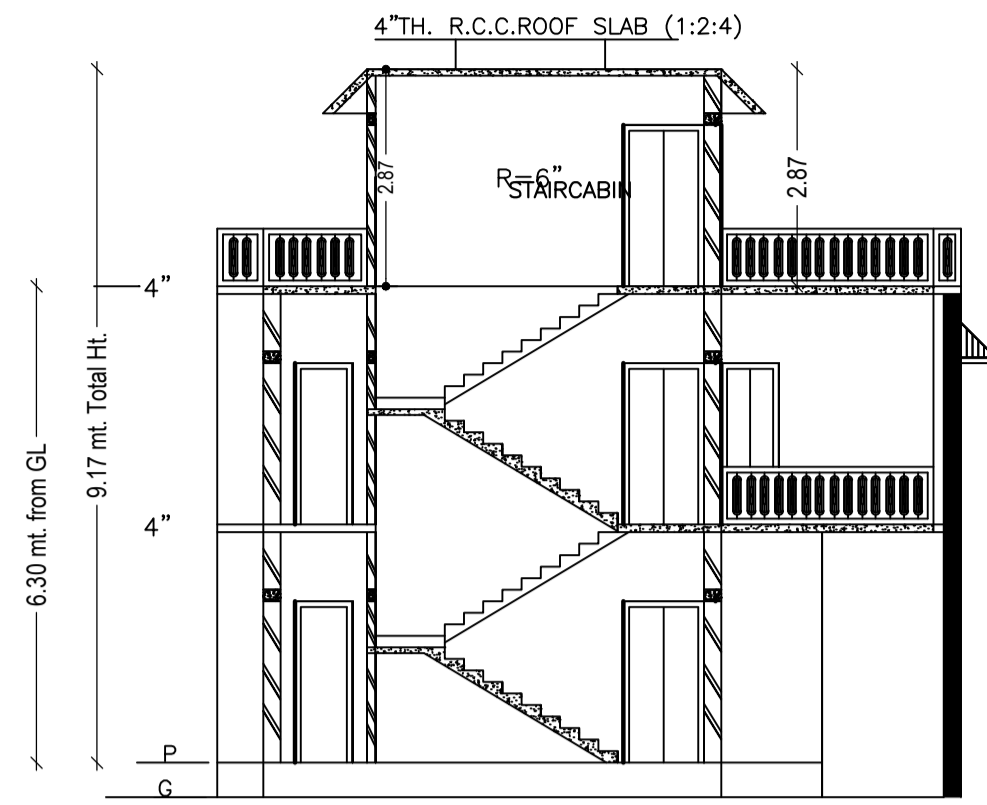

GROUND FLOOR PLAN (Proposed) (SCALE 1:100)



SECTION AT X-X

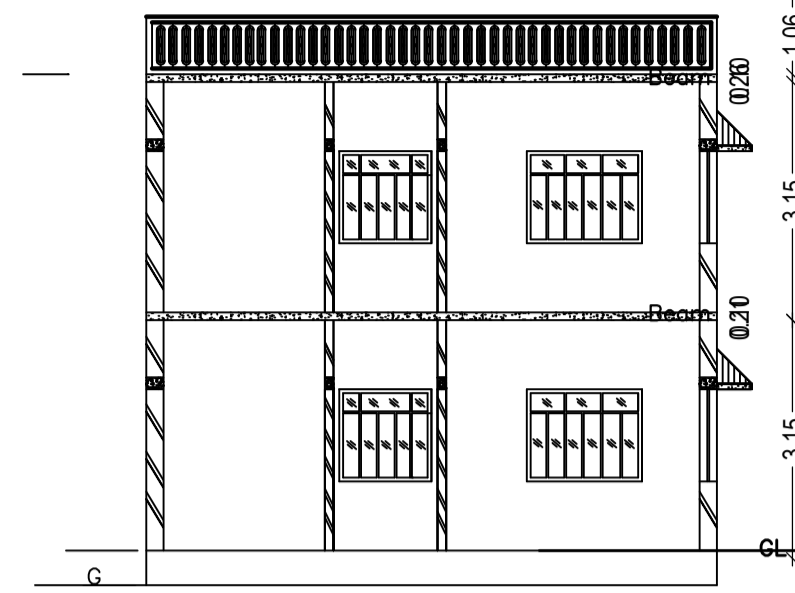

SECTION AT Y-Y

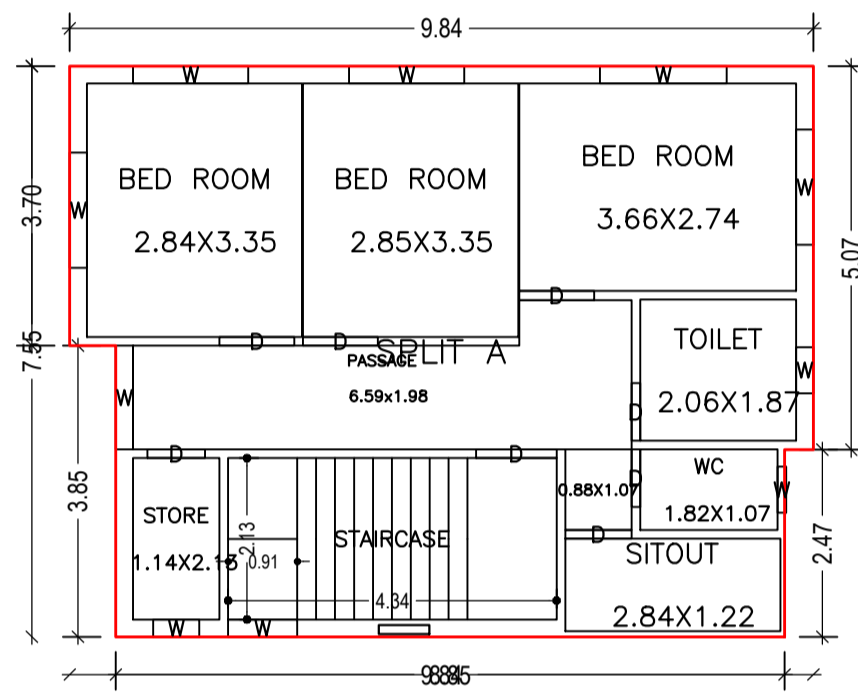

FIRST FLOOR PLAN (Proposed) (SCALE 1:100)

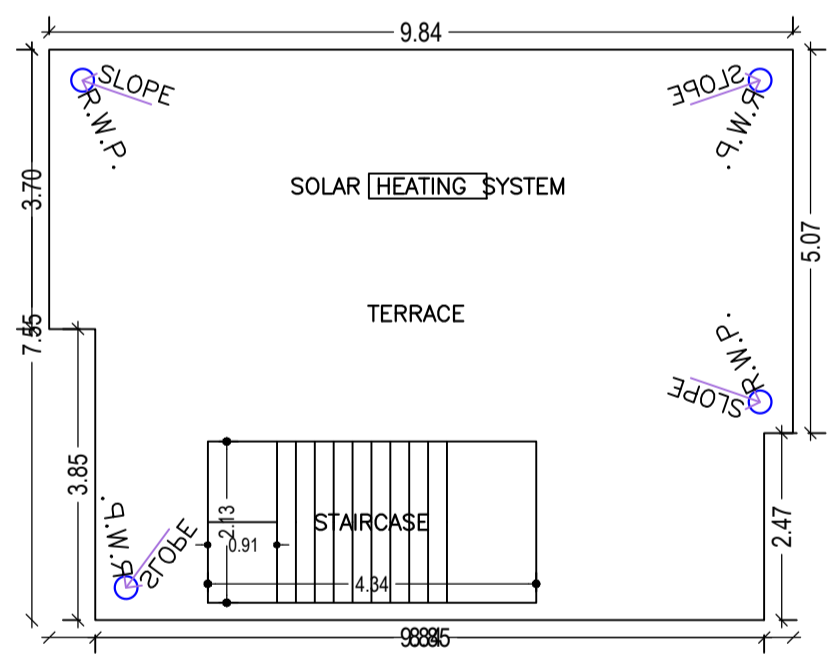

TERRACE FLOOR PLAN (SCALE 1:100)

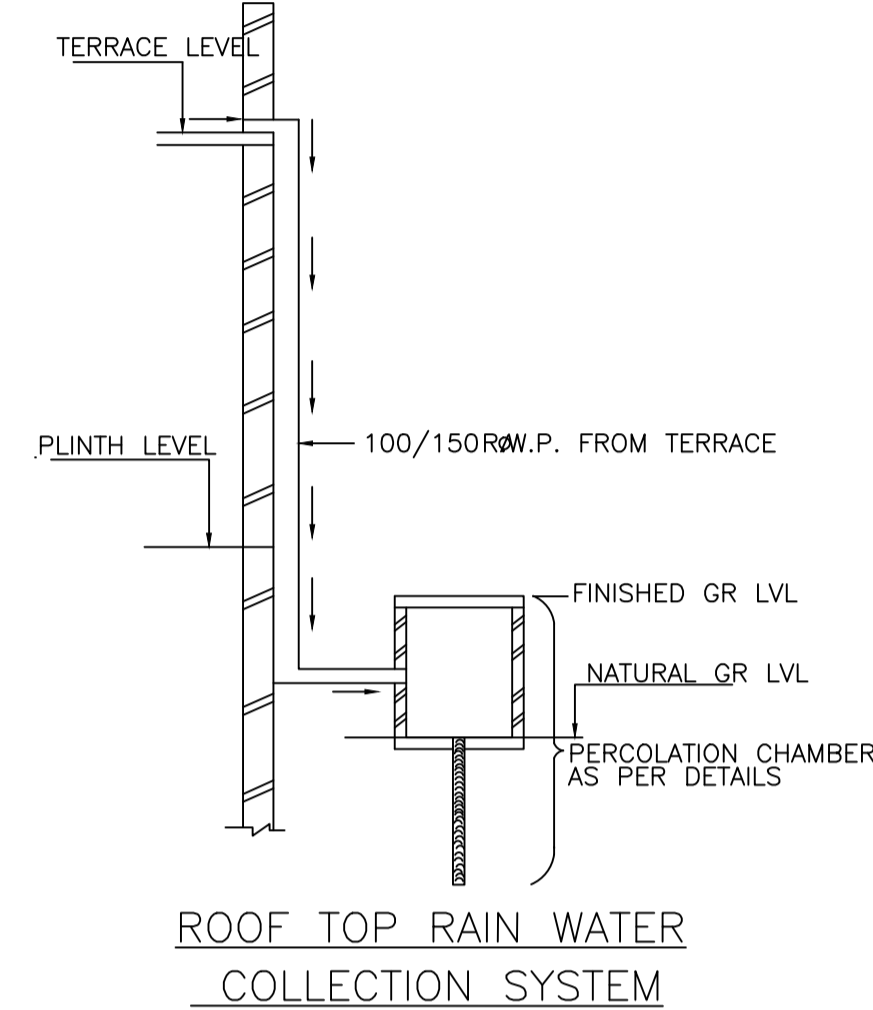

ROOF TOP RAIN WATER COLLECTION SYSTEM

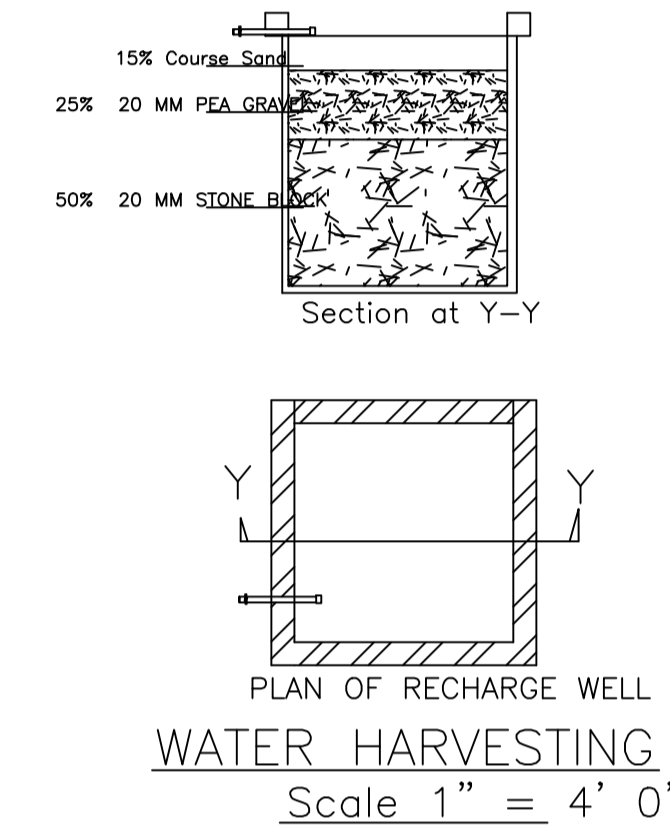

PLAN OF RECHARGE WELL WATER HARVESTING Scale 1" = 4' 0"

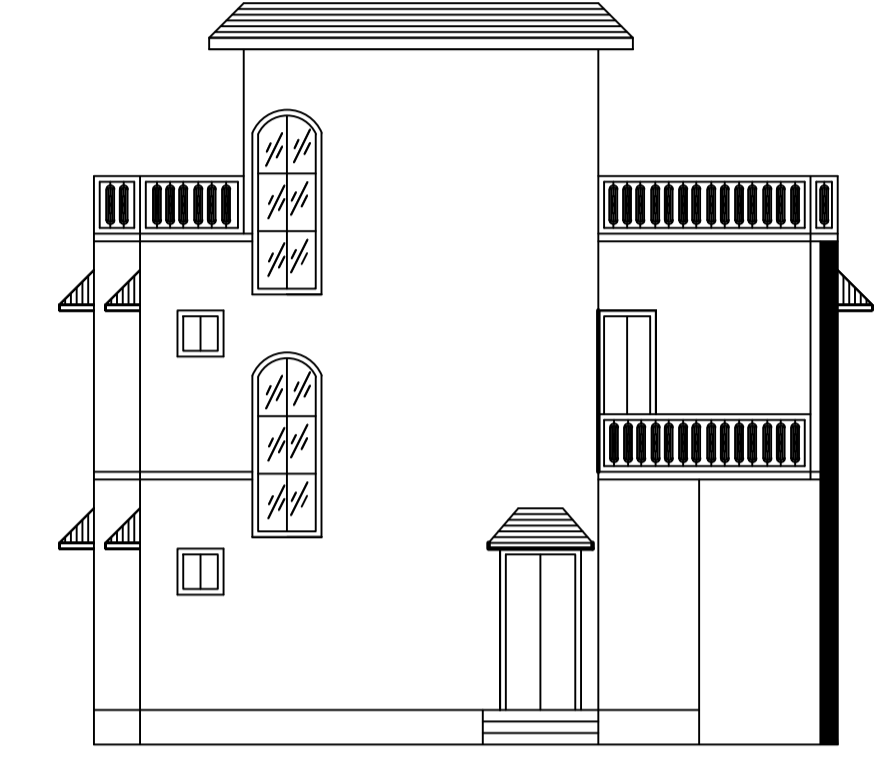

FRONT ELEVATION

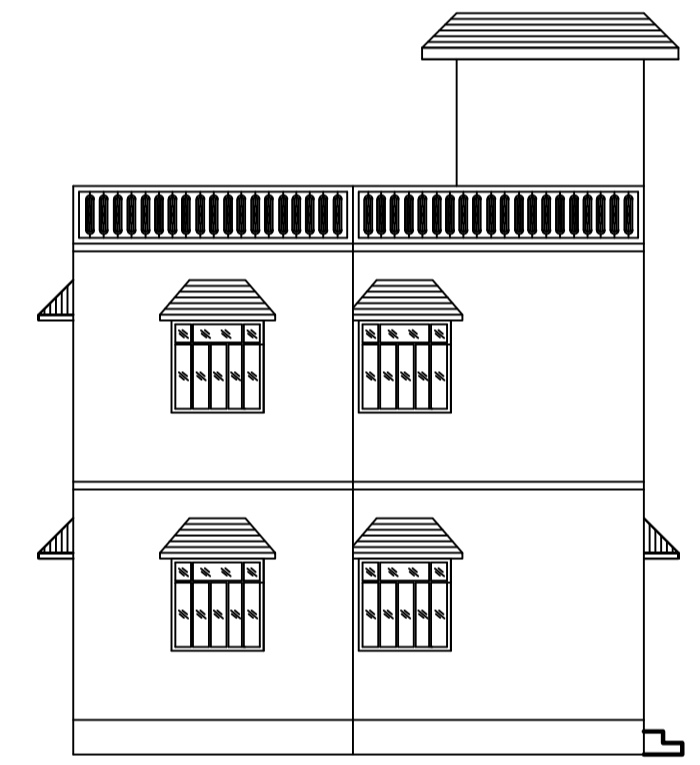

LEFT SIDE ELEVATION

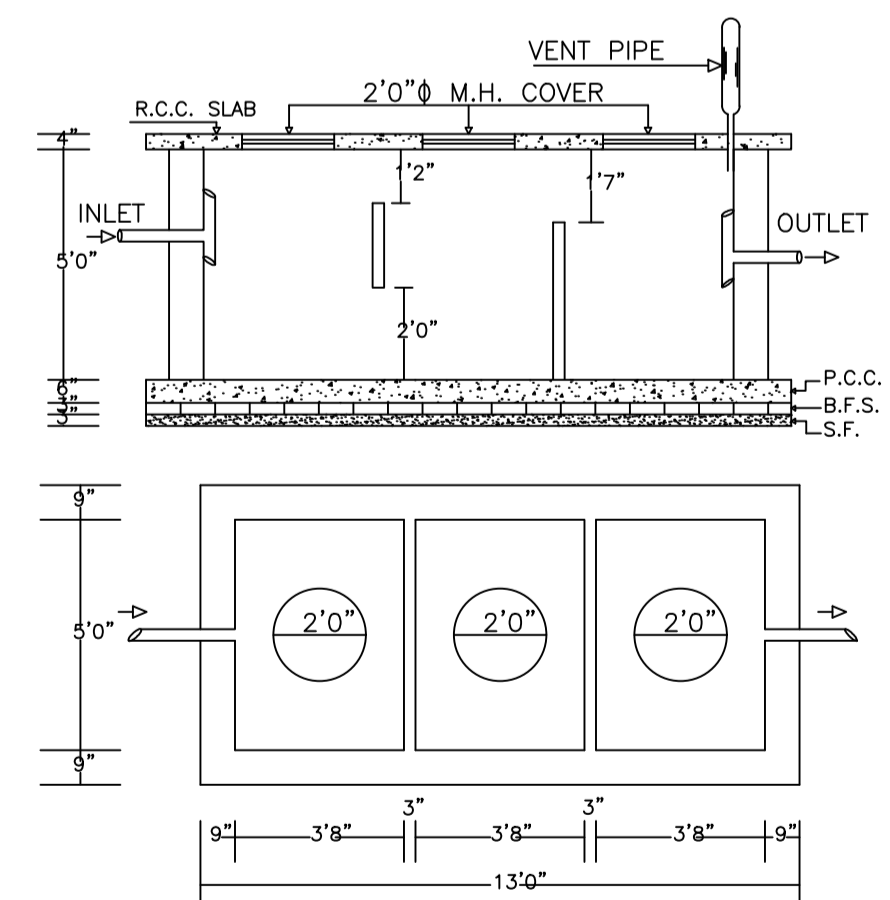

PLAN OF SEPTIC TANK SCALE:- 1" = 4' - 0"

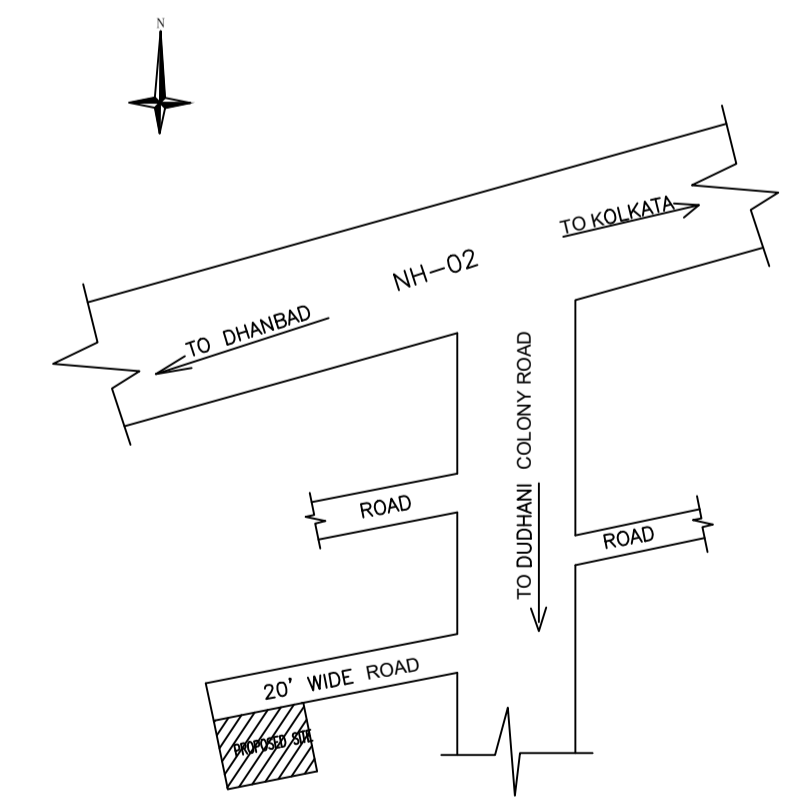
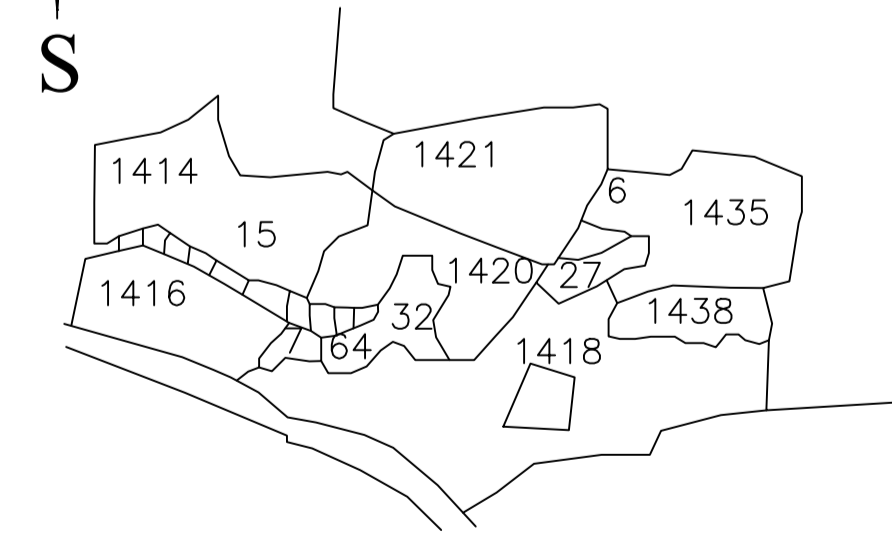
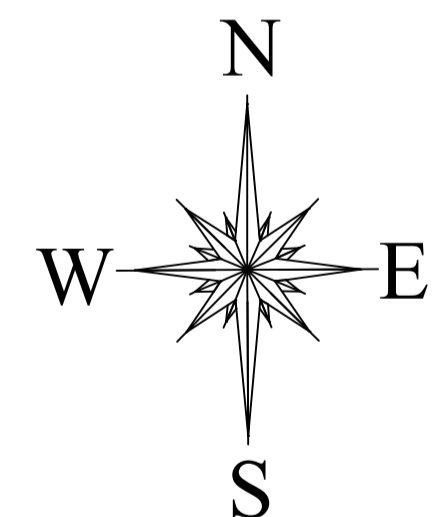

LTP NAME AND SIGNATURE	STRUCTURAL ENG'S NAME AND SIGNATURE	BUILDER NAME AND SIGNATURE	DIGITAL SIGNATURE
RAJEEV RANJAN SINGH MADA/ENG/0004/2019			