

SCHEDULE OF DOOR:

BUILDING NAME	NAME	LENGTH	HEIGHT	NOS
A (A)	d	0.88	2.10	12

SCHEDULE OF WINDOW/VENTILATION:

BUILDING NAME	NAME	LENGTH	HEIGHT	NOS
A (A)	w	1.02	1.20	04
A (A)	w	1.80	1.20	14

Floor Name	Total Built Up Area (Sq.mt.)	Proposed FAR Area (Sq.mt.) Resi.	Total FAR Area (Sq.mt.)	Total Consumed Additional FAR Area (Sq.mt.)	Tnmt (No.)
Ground Floor	78.47	78.47	78.47	78.47	01
First Floor	78.47	78.47	78.47	78.47	00
Terrace Floor	0.00	0.00	0.00	0.00	00
Total :	156.94	156.94	156.94	156.94	01
Total Number of Same Buildings :	1				
Total :	156.94	156.94	156.94	156.94	01

Proposal Basic Information

Proposal File No.	MADA/BP/0079/2020
Owner Name	SMT ASHA SINGH
Khata No	42 (NEW : 108)
Plot No	1889 (NEW : 2148)
Village Name	Kurmidih
Use	Residential
SubUse	Bungalow/ Dwelling / Non Apartment

AREA STATEMENT MINERAL	VERSION NO: 1.0.50	
AREA DEVELOPMENT AUTHORITY	VERSION DATE: 16/10/2020	
PROJECT DETAIL:		
Region: JHARKHAND URBAN	Plot Use: Residential	
LOCAL BODIES	Plot SubUse: Bungalow/ Dwelling / Non Apartment	
District: DHANBAD	PlotNearbyReligiousStructure: NA	
Authority: MINERAL AREA DEVELOPMENT AUTHORITY	Plot/SubPlot No: 1889 (NEW : 2148)	
Inward No: MADA/BP/0079/2020	North: Plot No. - plot 2148	
Application Type: General Proposal	South: Plot No. - plot 2148	
Project Type: Building Permission	East: Plot No. - plot 2156	
Nature of Development: New	West: Road Width - 4.84	
Location of Development Area: Old Area		
AREA DETAILS:		
AREA OF PLOT (Minimum)	(A)	130.16
NET AREA OF PLOT (Gross Plot Area - Deduction from Gross Plot area)	(A-Deductions)	130.16
Deduction for Balance Plot Area (from Gross Plot Area)		
Common Plot		19.60
Total		19.60
BALANCE AREA OF PLOT (Net Plot Area - Recreational/Amenity space)	(A-Deductions)	110.56
PLOT AREA FOR COVERAGE (Net Plot Area)	(A-Deductions)	130.16
Plot Area for FAR (Net Plot Area + Road Widening Area)	(A-Deductions)	130.16
COVERAGE CHECK		
Permissible Coverage area (70.00 %)		91.11
Proposed Coverage Area (60.29 %)		78.47
Total Prop. Coverage Area (60.29 %)		78.47
Balance coverage area (9.71 %)		12.64
FAR CHECK		
Perm. FAR Area (1.50)		195.24
Total Perm. FAR area		195.24
Residential FAR		156.94
Proposed FAR Area		156.94
Total Proposed FAR Area		156.94
Consumed FAR (Factor)		1.21
Balance FAR Area		38.30
BUILT UP AREA CHECK		
Total Proposed BuiltUp Area		156.94
ARCHITECT (Regd)	Sushil Kumar	
ENGINEER (Regd)		
SUPERVISOR (Regd)		
OWNER (Regd)	SMT ASHA SINGH	
DEVELOPMENT AUTHORITY		LOCAL BODY

COLOR INDEX

PLOT BOUNDARY	Black
ABUTTING ROAD	Red
PROPOSED CONSTRUCTION	Green
COMMON PLOT	Yellow
ROAD WIDENING AREA	Blue
EXISTING (To be retained)	Orange
EXISTING (To be demolished)	Purple

Buildingwise Floor FAR Details

Floor Name	Building Name A (A)		Total	
	Proposed Built Up Area (Sq.mt.)	Proposed FAR Area (Sq.mt.)	Total Proposed Built Up Area (Sq.mt.)	Total FAR Area (Sq.mt.)
Ground Floor	78.47	78.47	78.47	78.47
First Floor	78.47	78.47	78.47	78.47
Terrace Floor	0.00	0.00	0.00	0.00
Total :	156.94	156.94	156.94	156.94

Building USE/SUBUSE Details

Building Name	Building Use	Building SubUse	Building Structure
A (A)	Residential	Residential Bldg/Apartment	Non-Highrise

FAR & Tenement Details (Table 4c-1)

Building	No. of Same Bldg	Total Built Up Area (Sq.mt.)	Proposed FAR Area (Sq.mt.) Resi.	Total FAR Area (Sq.mt.)	Total Consumed Additional FAR Area (Sq.mt.)	Tnmt (No.)
A (A)	1	156.94	156.94	156.94	156.94	01
Grand Total :	1	156.94	156.94	156.94	156.94	01

UnitBUA Table for Building :A (A)

FLOOR	Name	UnitBUA Type	UnitBUA Area	Carpet Area	No. of Rooms	No. of Tenement
GROUND FLOOR PLAN	SPLIT 1	FLAT	156.94	156.89	7	1
FIRST FLOOR PLAN	SPLIT 1	FLAT	0.00	0.00	7	0
Total:	-	-	156.94	156.89	14	1

LTP NAME AND SIGNATURE	STRUCTURAL ENG'S NAME AND SIGNATURE	BUILDER NAME AND SIGNATURE	DIGITAL SIGNATURE
Sushil Kumar MADA/ENG/0009/2019			

Proposal Basic Information	
Proposal File No.	MADA/BP/0079/2020
Owner Name	SMT ASHA SINGH
Khata No	42 (NEW : 108)
Plot No	1889 (NEW : 2148)
Village Name	Kurmidih
Use	Residential
SubUse	Bungalow/ Dwelling / Non Apartment

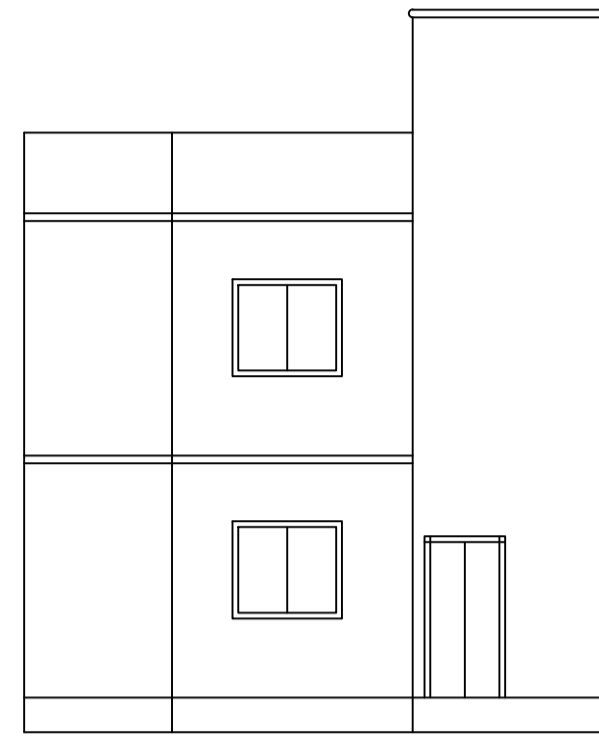

FRONT ELEVATION

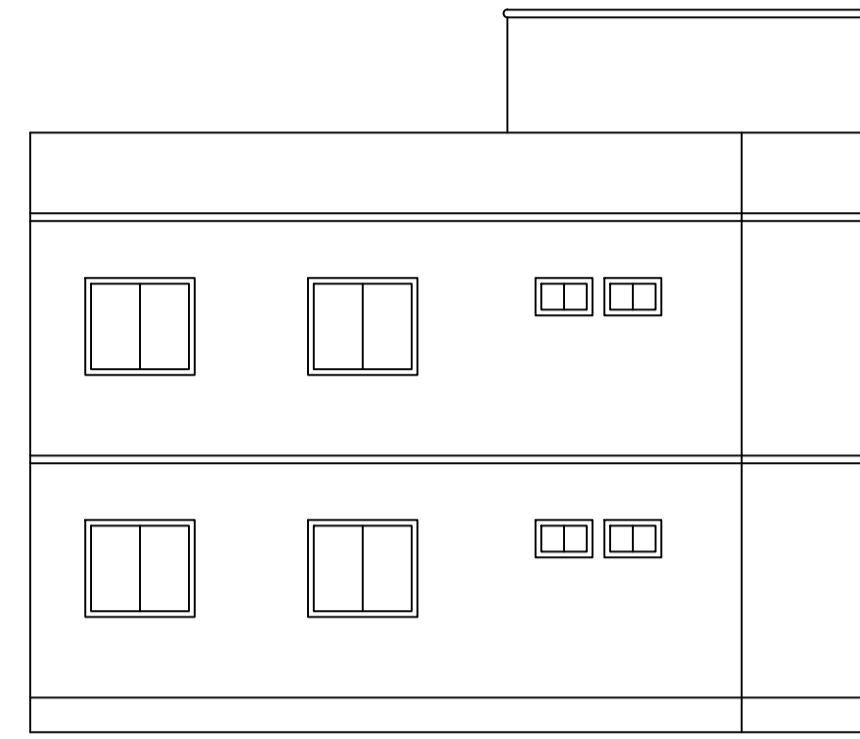

LEFT SIDE ELEVATION

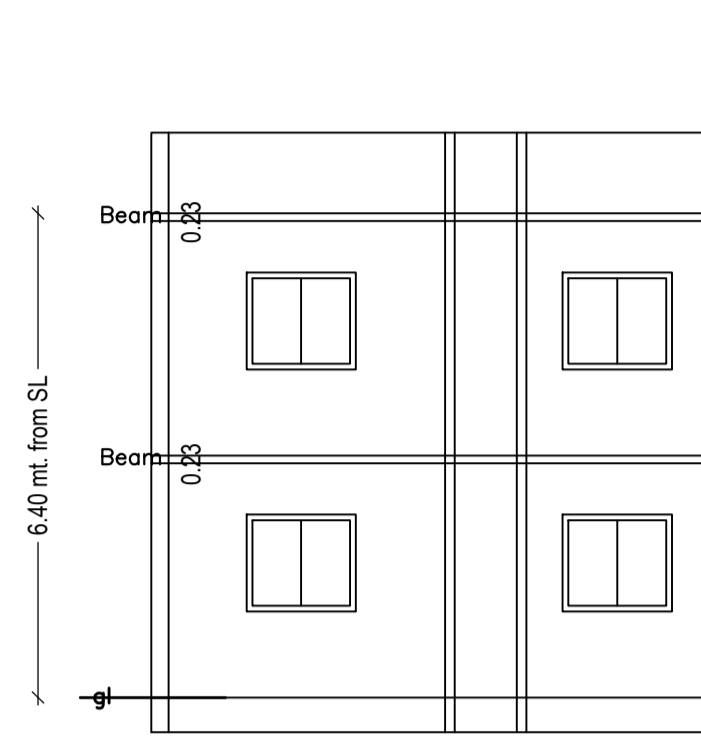

SECTIONAL AT X-X

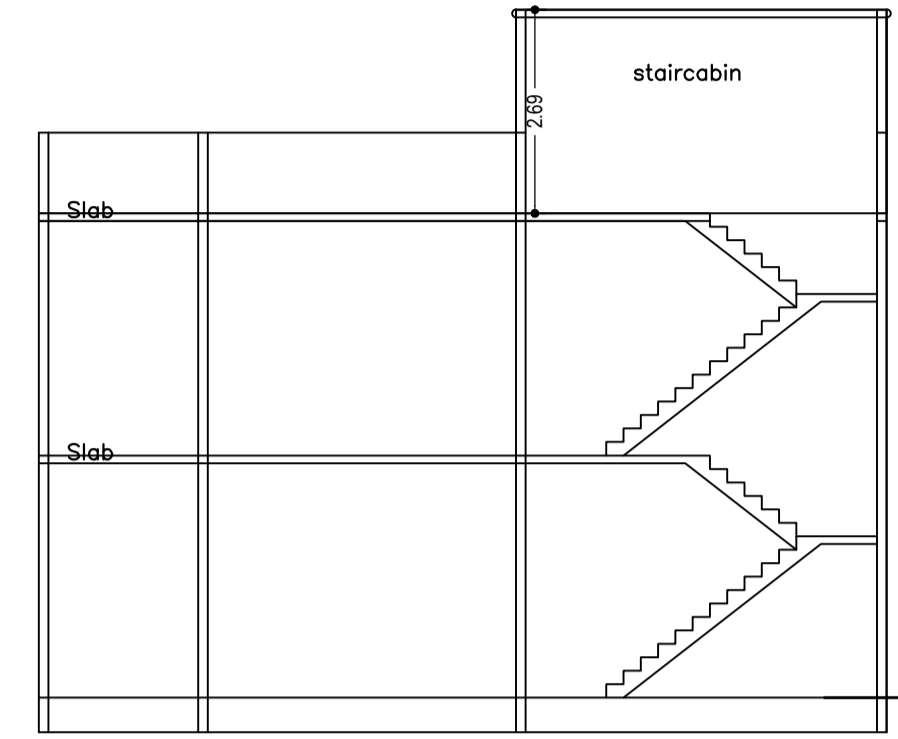

SECTIONAL AT Y-Y

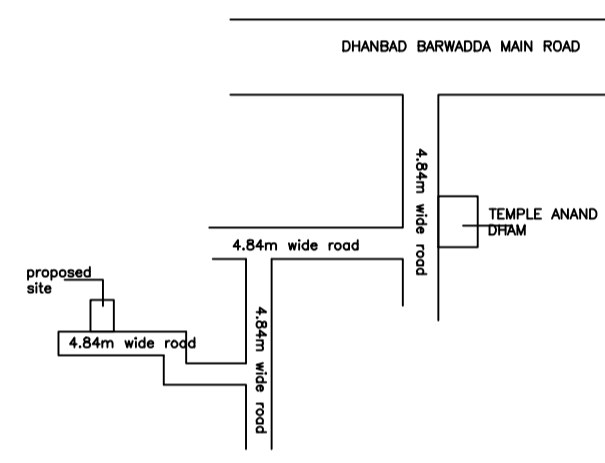

LOCATION

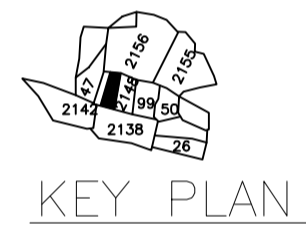

KEY PLAN

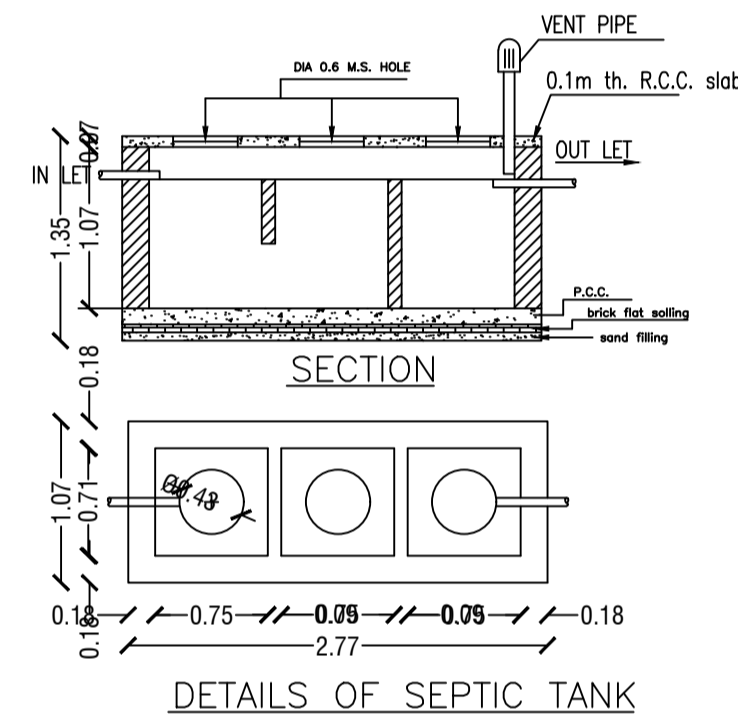

DETAILS OF SEPTIC TANK

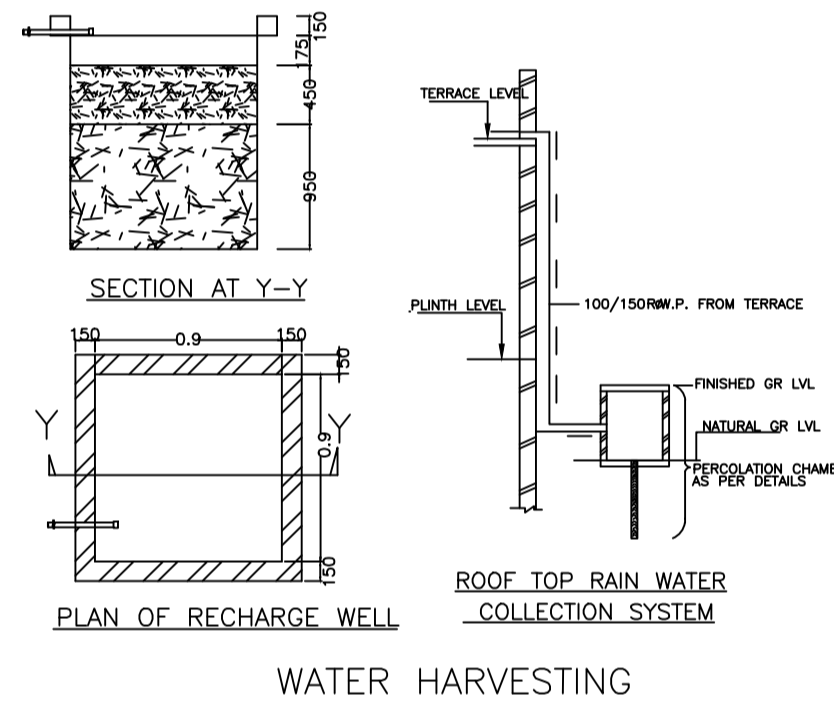

WATER HARVESTING

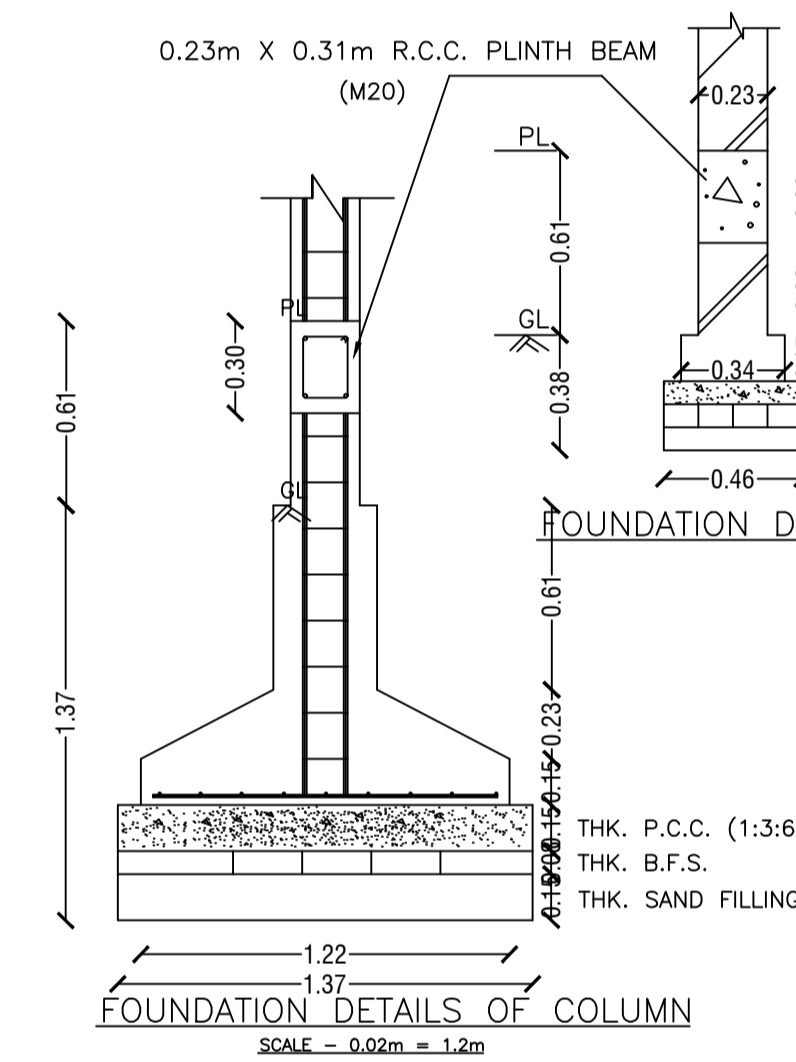

FOUNDATION DETAILS OF COLUMN

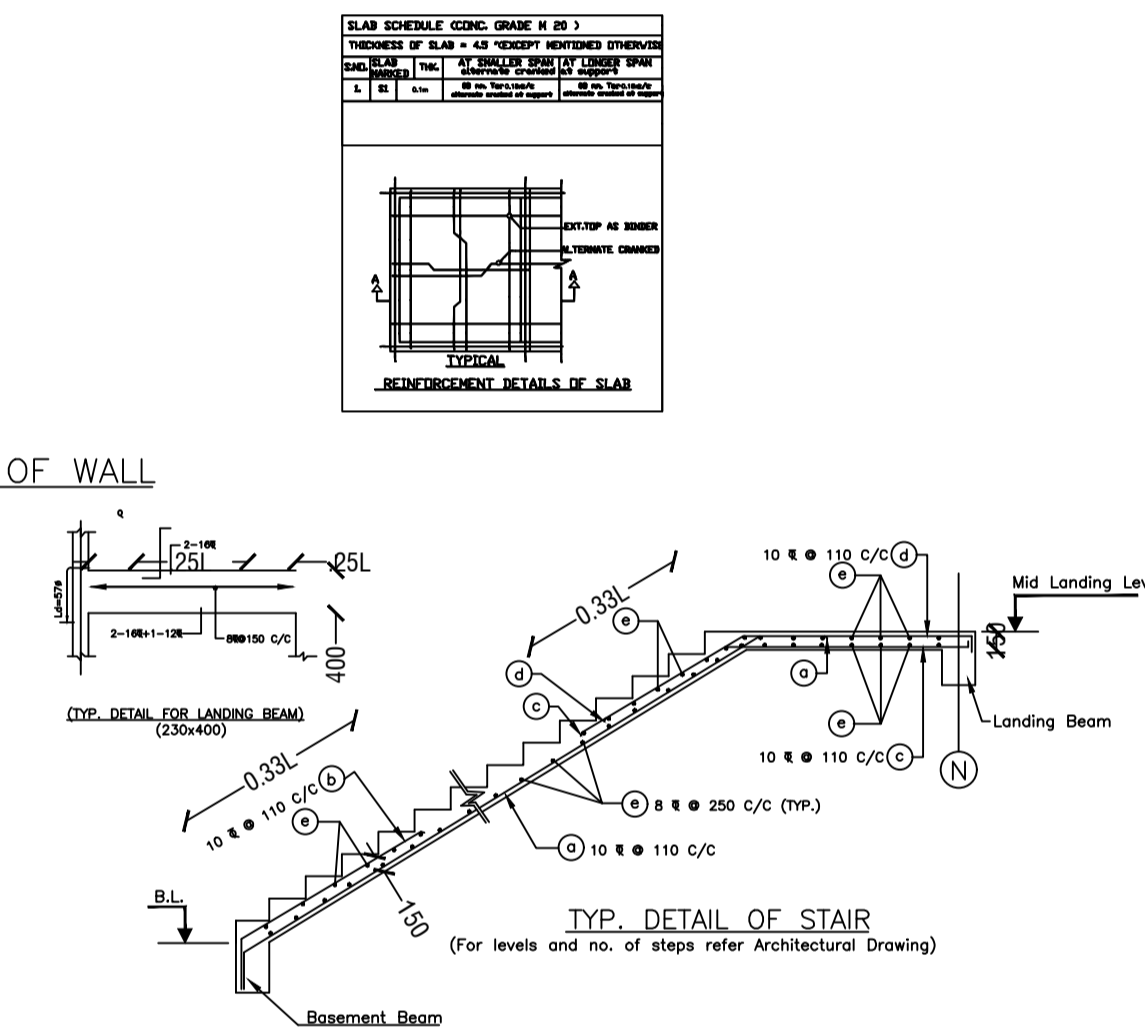

TYP. DETAIL OF STAIR

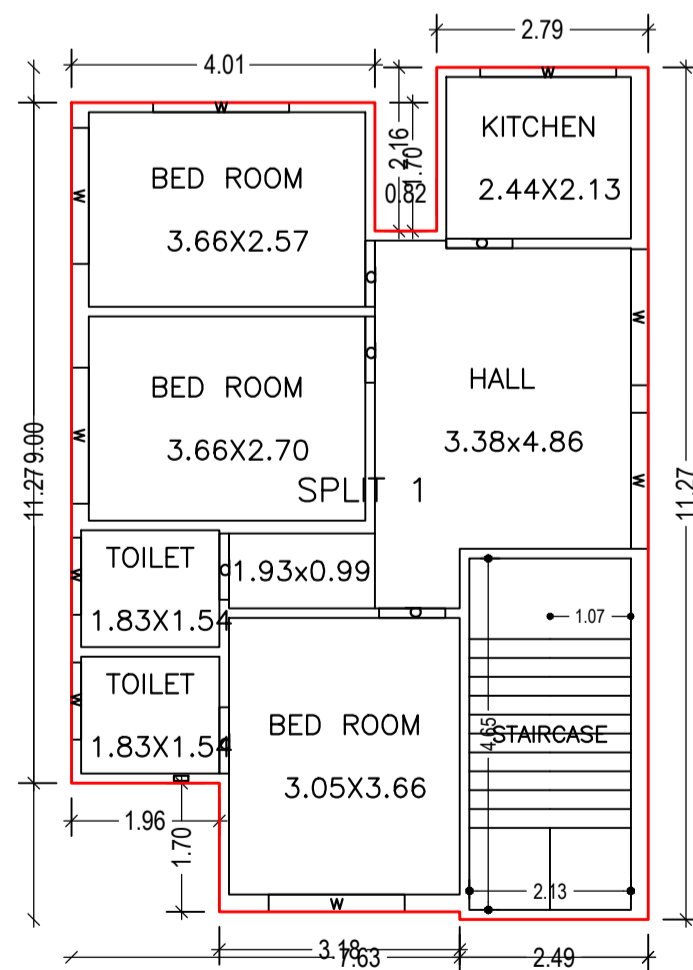

GROUND FLOOR PLAN (Proposed) (SCALE 1:100)

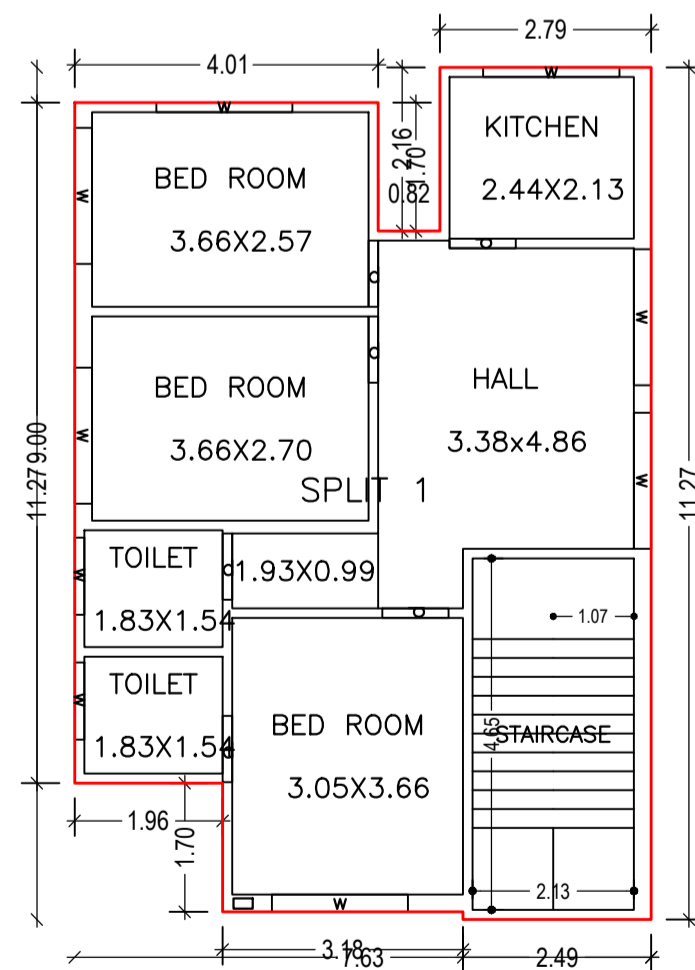

FIRST FLOOR PLAN (Proposed) (SCALE 1:100)

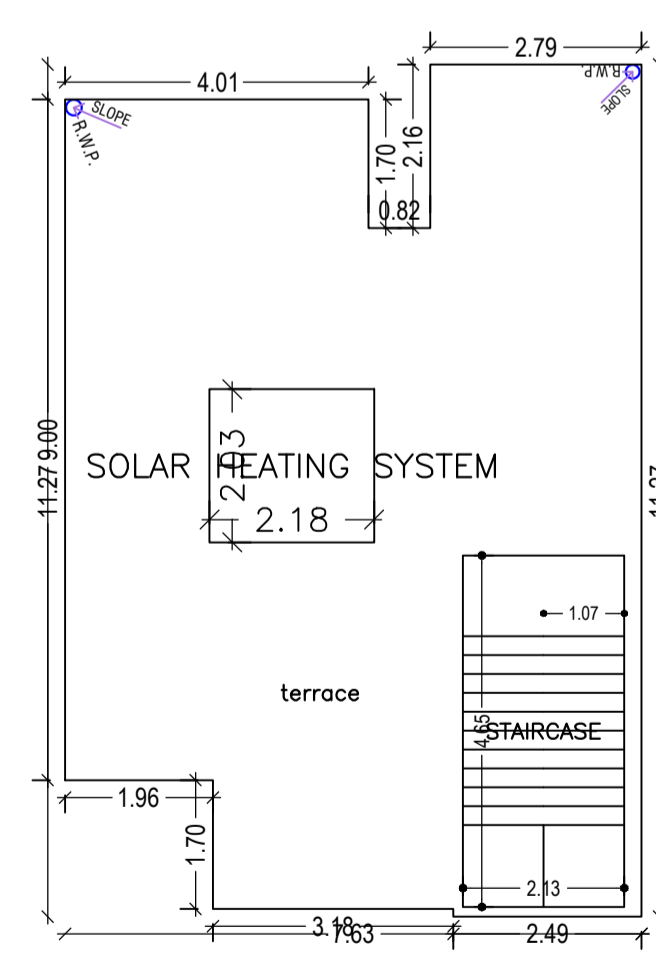

TERRACE FLOOR PLAN (SCALE 1:100)

LTP NAME AND SIGNATURE	STRUCTURAL ENG'S NAME AND SIGNATURE	BUILDER NAME AND SIGNATURE	DIGITAL SIGNATURE
Sushil Kumar MADA/ENG/0009/2019			