

Proposal Basic Information

Proposal File No.	MADA/EP/0076/2020
Owner Name	SRI OM PRAKASH VISHWAKARMA
Khata No	NEW - 60 , OLD - 14
Plot No	NEW - 698 , OLD - 764 , 765
Village Name	Narayanpur
Use	Residential
SubUse	Bungalow/ Dwelling / Non Apartment

AREA STATEMENT MINERAL AREA DEVELOPMENT AUTHORITY	VERSION NO.: 1.0.49 VERSION DATE: 22/06/2020
PROJECT DETAIL:	
Region : JHARKHAND URBAN LOCAL BODIES	Plot Use: Residential
District: DHANBAD	Plot SubUse: Bungalow/ Dwelling / Non Apartment
Authority: MINERAL AREA DEVELOPMENT AUTHORITY	PlotNearby/ReligiousStructure: NA
Inward No: MADA/BP/0076/2020	Plot/SubPlot No: NEW - 698 , OLD - 764 , 765
Application Type: General Proposal	North: Road Width - 6.1 M WIDE ROAD
Project Type: Building Permission	South: Plot No. - PART OF THIS PLOT
Nature of Development: New	East: Plot No. - LOT NO - 21
Location of Development Area: Old Area	West: Plot No. - LOT NO - 19
AREA DETAILS:	
AREA OF PLOT (Minimum)	(A) 184.97 SQ.MT.
NET AREA OF PLOT(Gross Plot Area - Deduction from Gross Plot area)	(A-Deductions) 184.97
Deduction for Balance Plot Area(from Gross Plot Area)	
Common Plot	13.78
Total	13.78
BALANCE AREA OF PLOT(Net Plot Area - Recreational/Amenity space)	(A-Deductions) 171.19
PLOT AREA FOR COVERAGE(Net Plot Area)	(A-Deductions) 184.97
Plot Area for FAR (Net Plot Area + Road Widening Area)	(A-Deductions) 184.97
COVERAGE CHECK	
Permissible Coverage area (70.03 %)	129.48
Proposed Coverage Area (69.03 %)	127.68
Total Prop. Coverage Area (69.03 %)	127.68
Balance coverage area (0.97 %)	1.80
FAR CHECK	
Perm. FAR Area (1.80)	332.95
Total Perm. FAR area	332.95
Residential FAR	255.36
Proposed FAR Area	255.36
Total Proposed FAR Area	255.36
Consumed FAR (Factor)	1.38
Balance FAR Area	77.59
BUILT UP AREA CHECK	
Total Proposed BuiltUp Area	255.36
ARCHITECT (Regd)	AMARENDRA KUMAR
ENGINEER (Regd)	
SUPERVISOR (Regd)	
OWNER (Regd)	SRI OM PRAKASH VISHWAKARMA
DEVELOPMENT AUTHORITY	LOCAL BODY

COLOR INDEX

PLOT BOUNDARY	Black
ABUTTING ROAD	Green
PROPOSED CONSTRUCTION	Red
COMMON PLOT	Yellow
ROAD WIDENING AREA	Orange
EXISTING (To be retained)	Blue
EXISTING (To be demolished)	Light Blue

Buildingwise Floor FAR Details

Floor Name	Building Name A (A)		Total	
	Proposed Built Up Area (Sq.mt.)	Proposed FAR Area (Sq.mt.)	Total Proposed Built Up Area (Sq.mt.)	Total FAR Area (Sq.mt.)
Ground Floor	127.68	127.68	127.68	127.68
First Floor	127.68	127.68	127.68	127.68
Terrace Floor	0.00	0.00	0.00	0.00
Total :	255.36	255.36	255.36	255.36

Building USE/SUBUSE Details

Building Name	Building Use	Building SubUse	Building Structure
A (A)	Residential	Bungalow/ Dwelling / Non Apartment	Non-Highrise

FAR & Tenement Details (Table 4c-1)

Building	No. of Same Bldg	Total Built Up Area (Sq.mt.)	Proposed FAR Area (Sq.mt.) Resi.	Total FAR Area (Sq.mt.)	Total Consumed Additional FAR Area (Sq.mt.)	Tnmt (No.)
A (A)	1	255.36	255.36	255.36	255.36	01
Grand Total :	1	255.36	255.36	255.36	255.36	01

UnitBUA Table for Building :A (A)

FLOOR	Name	UnitBUA Type	UnitBUA Area	Carpet Area	No. of Rooms	No. of Tenement
FIRST FLOOR	SPLIT A	FLAT	0.00	0.00	9	0
GROUND FLOOR	SPLIT A	FLAT	255.36	255.21	8	1
Total:	-	-	255.36	255.21	17	1

SCHEDULE OF DOOR:

BUILDING NAME	NAME	LENGTH	HEIGHT	NOS
A (A)	D	0.76	2.10	06
A (A)	D	0.91	2.10	02
A (A)	D	1.06	2.10	04
A (A)	D	1.07	2.10	05

SCHEDULE OF WINDOW/VENTILATION:

BUILDING NAME	NAME	LENGTH	HEIGHT	NOS
A (A)	W	0.61	1.20	04
A (A)	W	0.91	1.20	04
A (A)	W	1.22	1.20	02
A (A)	W	1.52	1.20	14

Building :A (A)

Floor Name	Total Built Up Area (Sq.mt.)	Proposed FAR Area (Sq.mt.) Resi.	Total FAR Area (Sq.mt.)	Total Consumed Additional FAR Area (Sq.mt.)	Tnmt (No.)
Ground Floor	127.68	127.68	127.68	127.68	01
First Floor	127.68	127.68	127.68	127.68	00
Terrace Floor	0.00	0.00	0.00	0.00	00
Total :	255.36	255.36	255.36	255.36	01
Total Number of Same Buildings :	1				
Total :	255.36	255.36	255.36	255.36	01

LTP NAME AND SIGNATURE	STRUCTURAL ENG'S NAME AND SIGNATURE	BUILDER NAME AND SIGNATURE	DIGITAL SIGNATURE
AMARENDRA KUMAR MADA/ENG/0008/2019			

Proposal Basic Information	
Proposal File No.	MADA/EN/0076/2020
Owner Name	SRI OM PRAKASH VISHWAKARMA
Khata No	NEW - 60 , OLD - 14
Plot No	NEW - 698 , OLD - 764 , 765
Village Name	Narayanpur
Use	Residential
SubUse	Bungalow/ Dwelling / Non Apartment

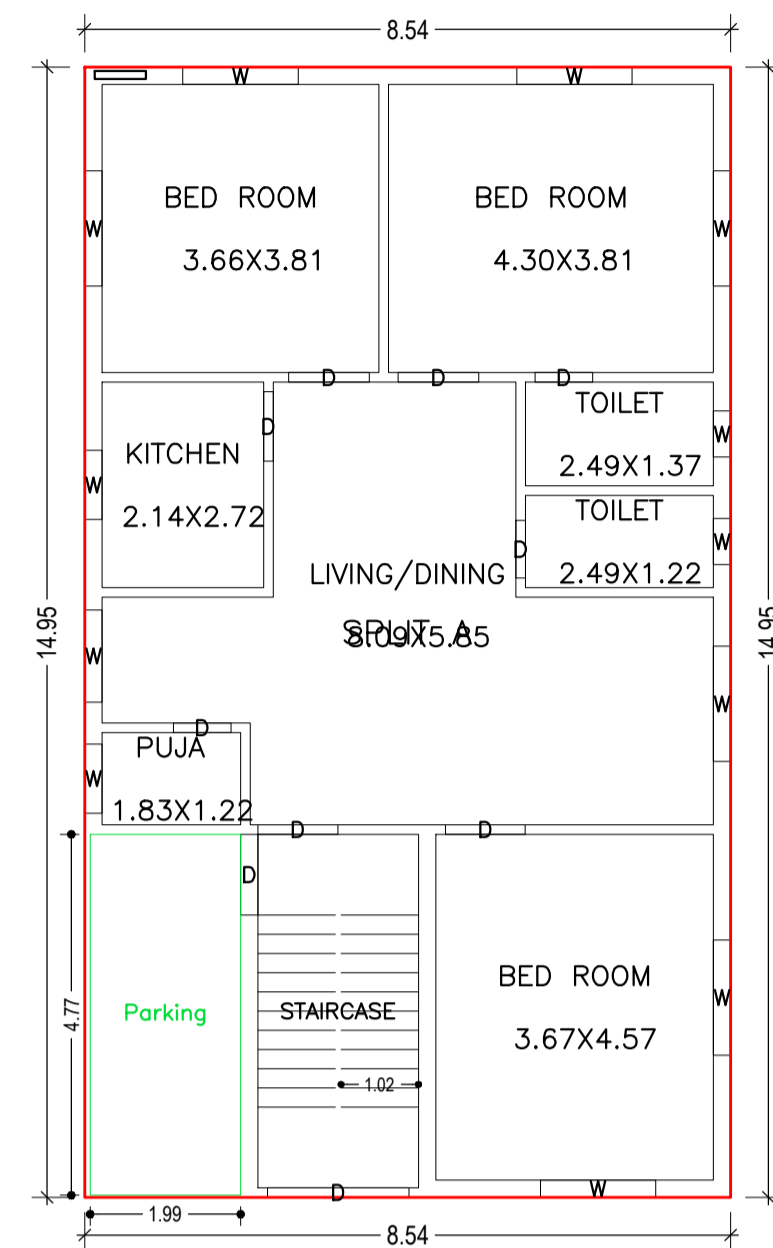

GROUND FLOOR PLAN
(Proposed)
(SCALE 1:100)

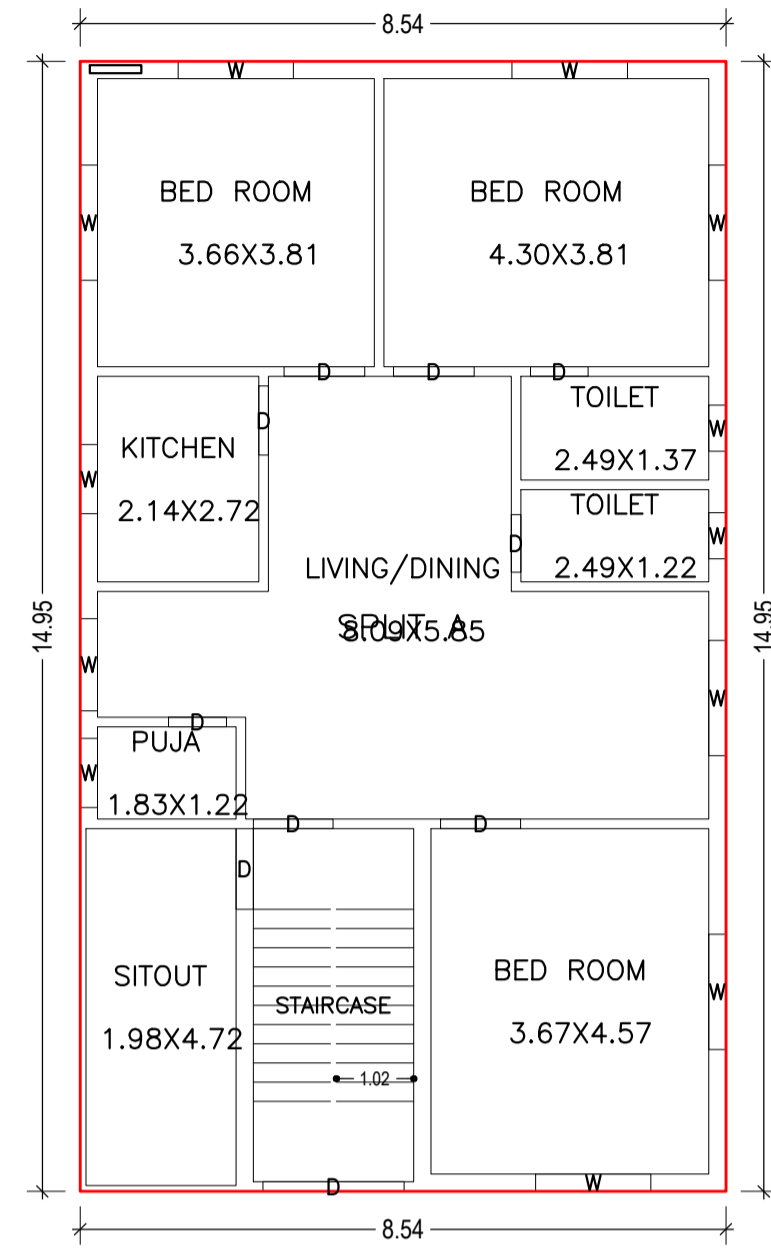

FIRST FLOOR PLAN
(Proposed)
(SCALE 1:100)

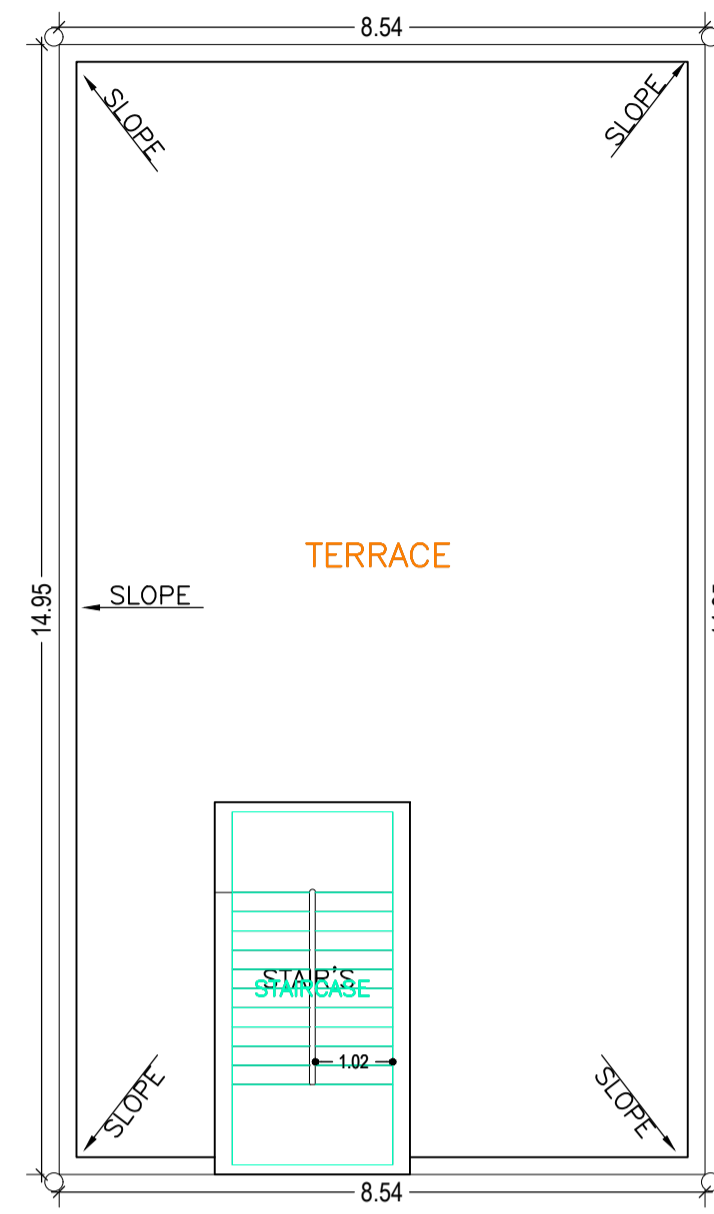

TERRACE FLOOR PLAN
(SCALE 1:100)

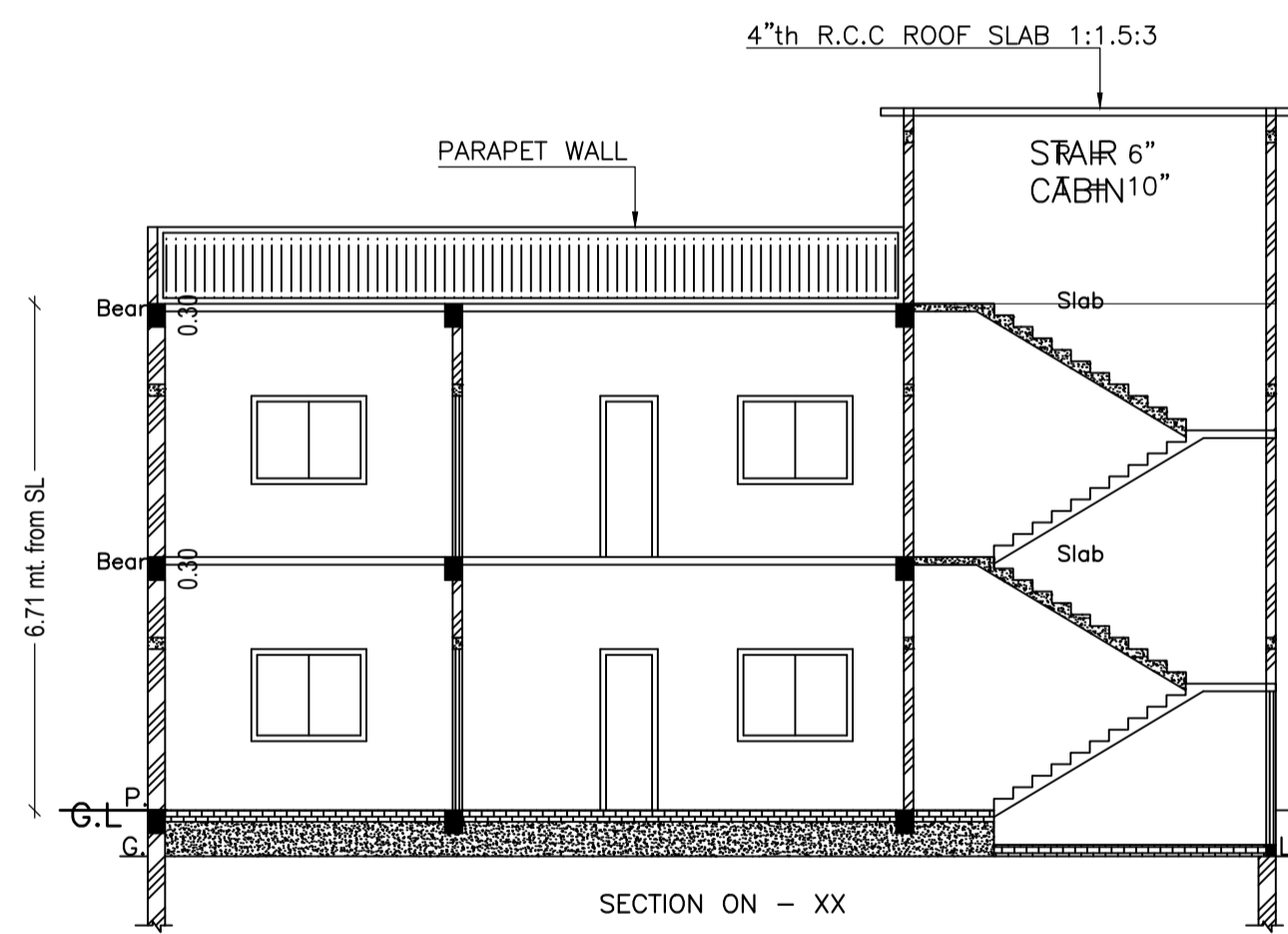
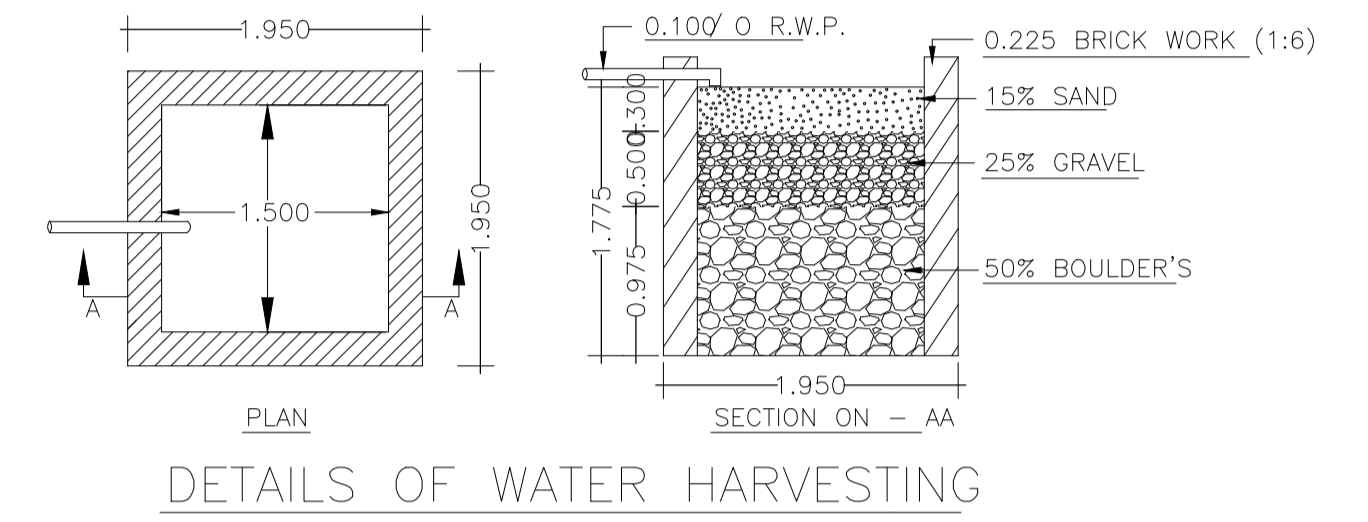
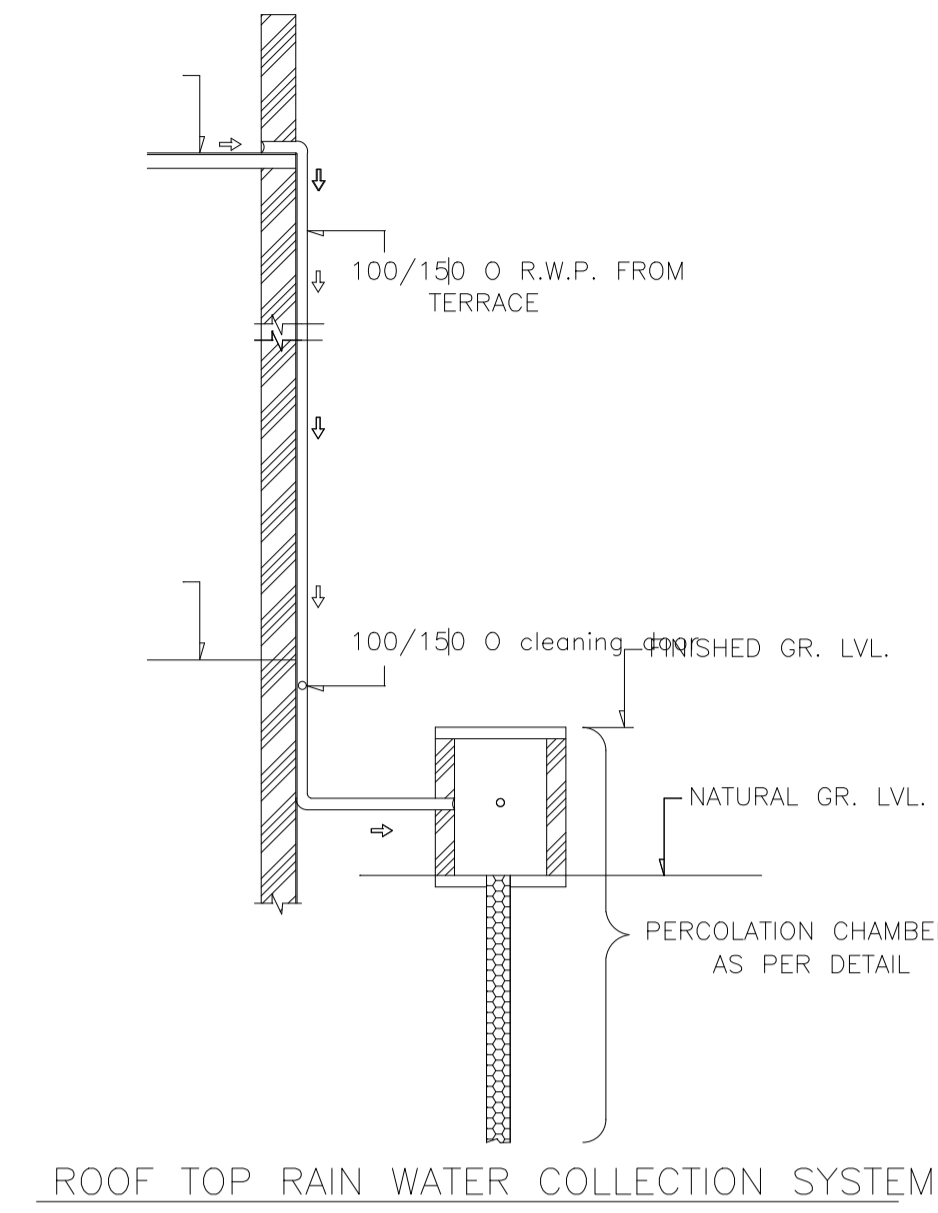

SECTION ON - XX

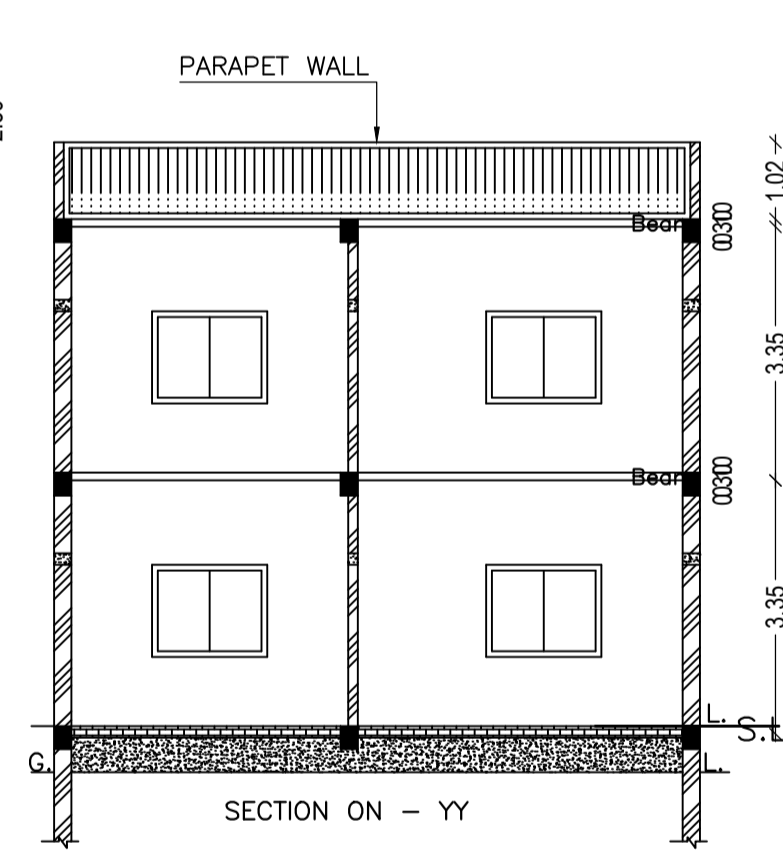

SECTION ON - YY

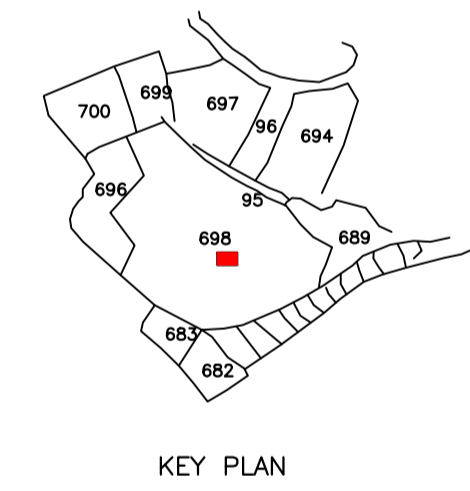

KEY PLAN

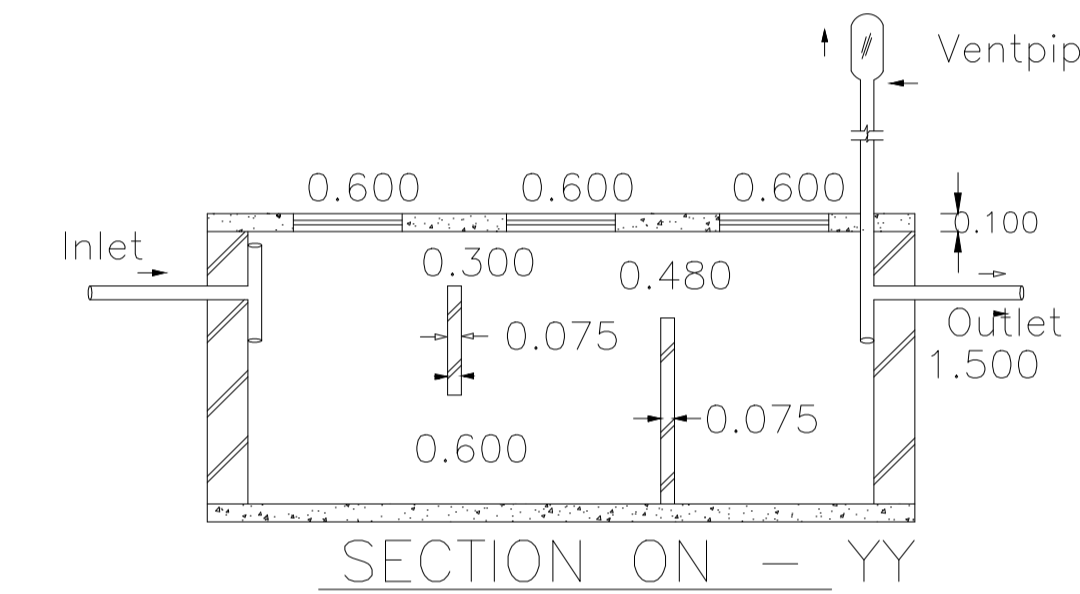

SECTION ON - YY



DETAILS OF SEPTIC TANK

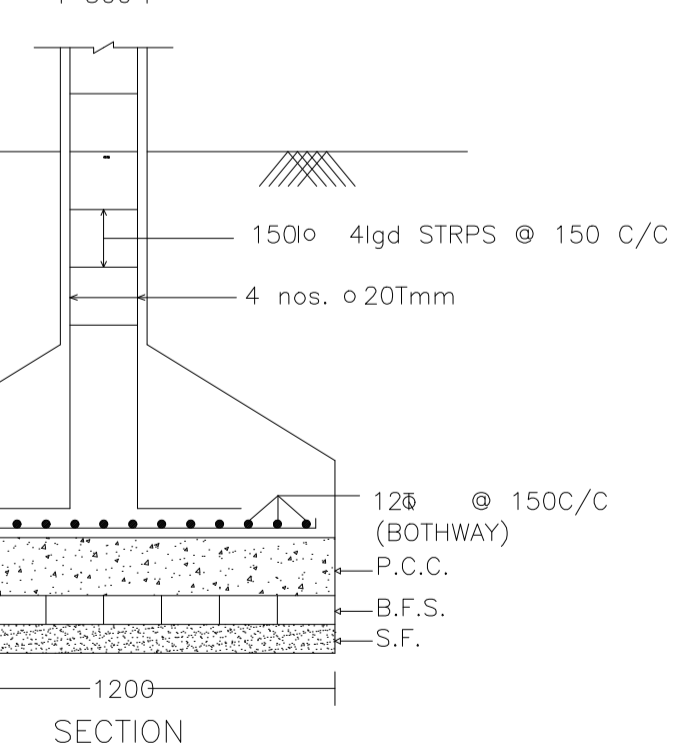
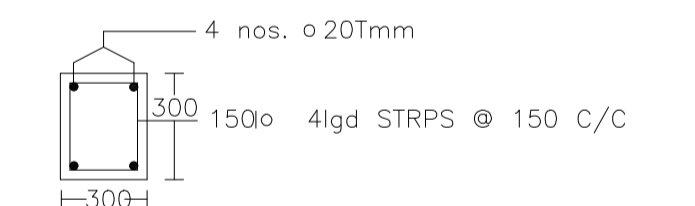

DETAIL OF COLUMNS

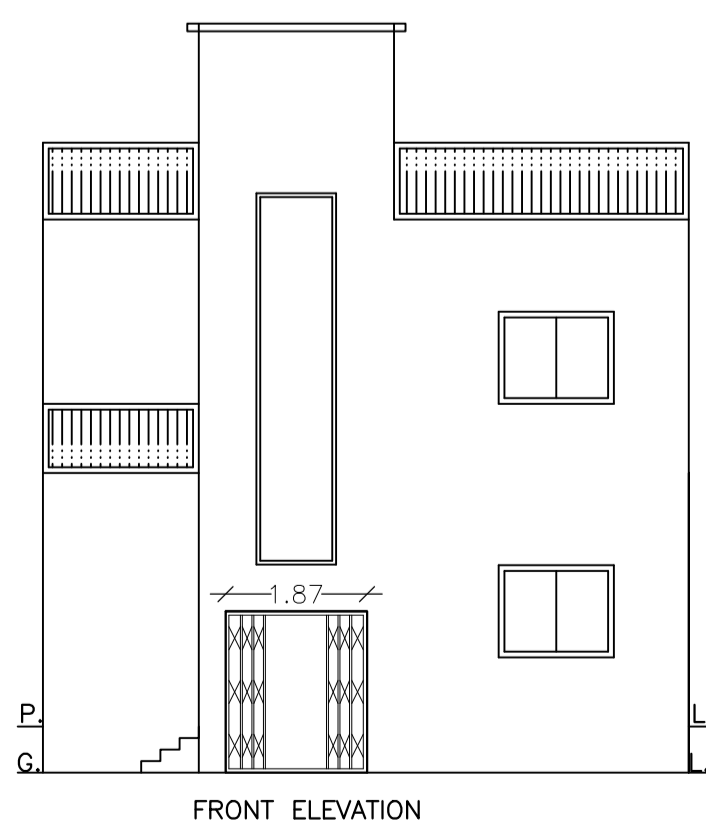

FRONT ELEVATION

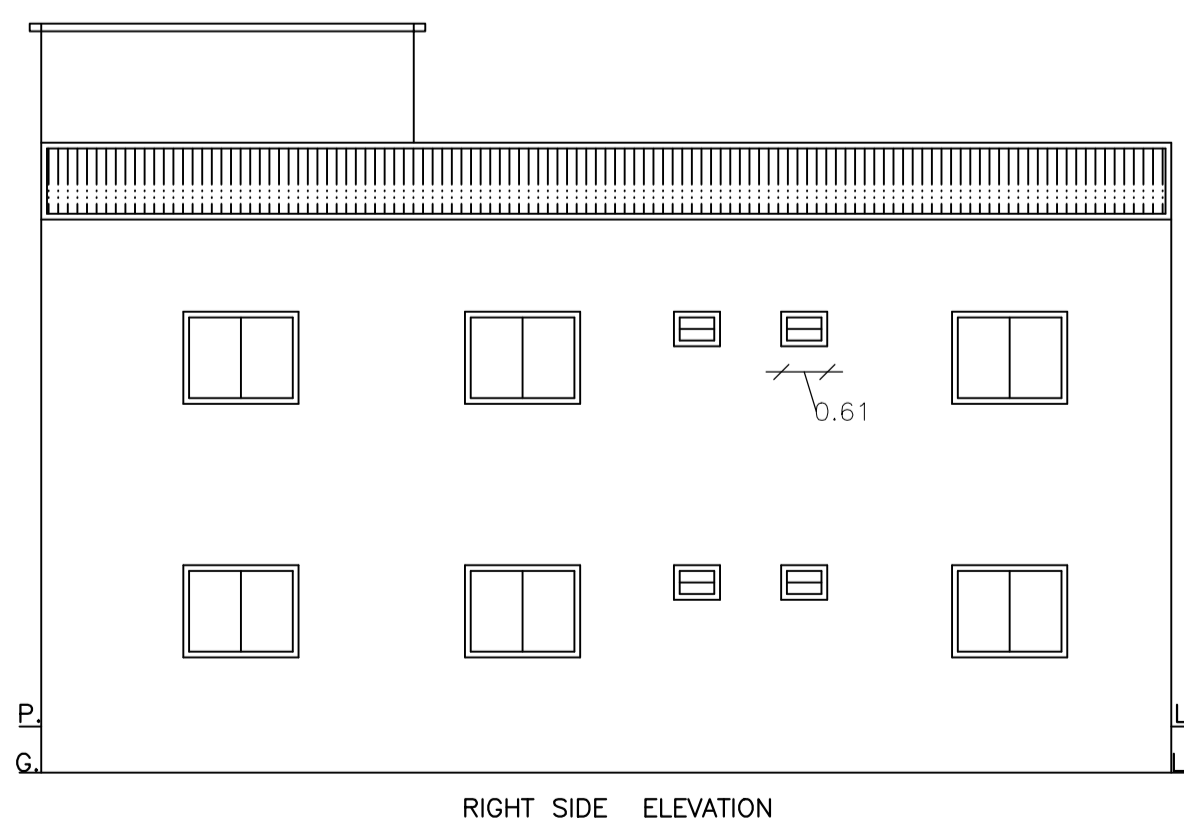

RIGHT SIDE ELEVATION

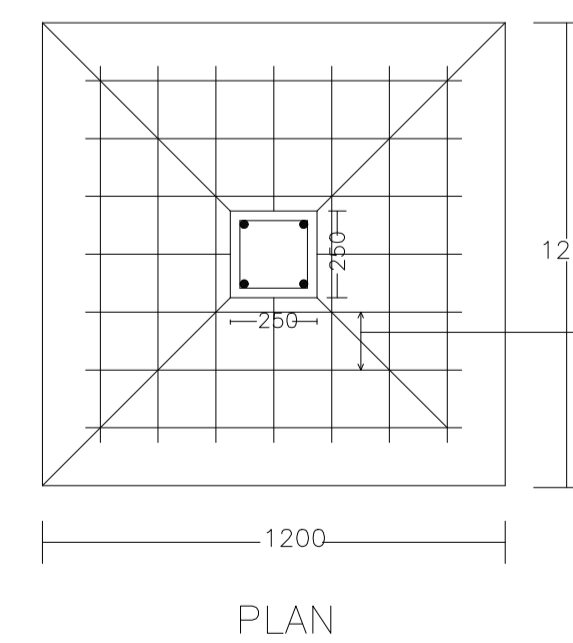
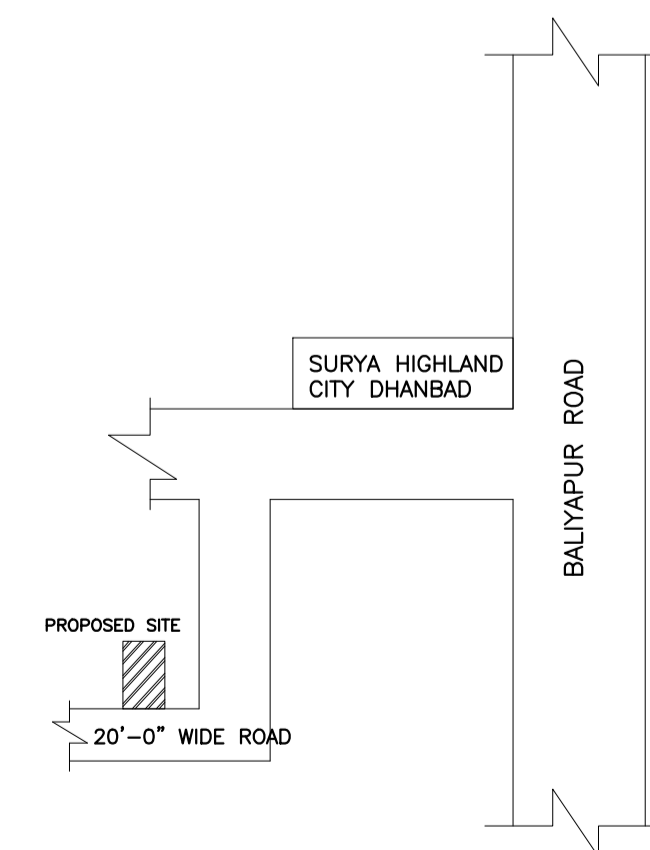

PLAN

LTP NAME AND SIGNATURE	STRUCTURAL ENG'S NAME AND SIGNATURE	BUILDER NAME AND SIGNATURE	DIGITAL SIGNATURE
AMARENDRA KUMAR MADA/ENG/0008/2019			