

Proposal Basic Information	
Proposal File No.	MADA/BP/0103/2021
Owner Name	SRI. MITHILESH KUMAR SINGH
Khata No	OLD KHATA NO-69,NEW KHATA NO-134
Plot No	OLD PLOT NO. 517, NEW PLOT NO. 1456
Village Name	Jialgora
Use	Residential
SubUse	Bungalow/ Dwelling / Non Apartment

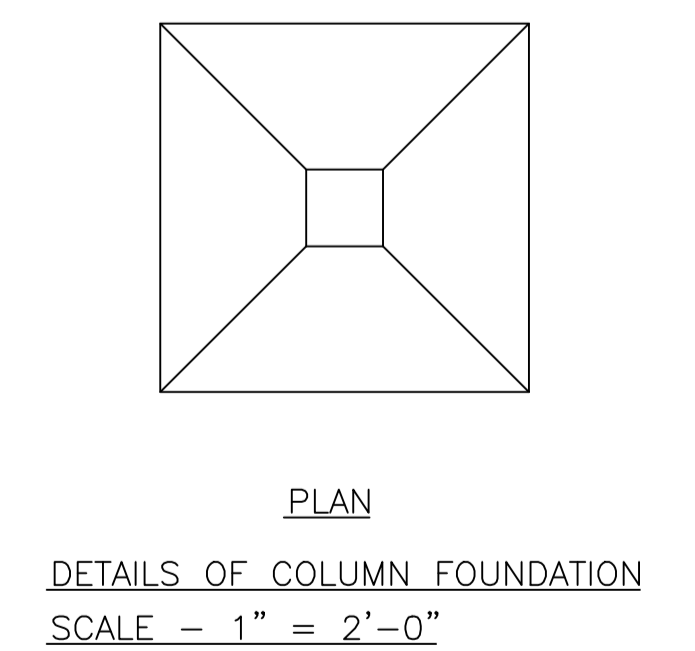
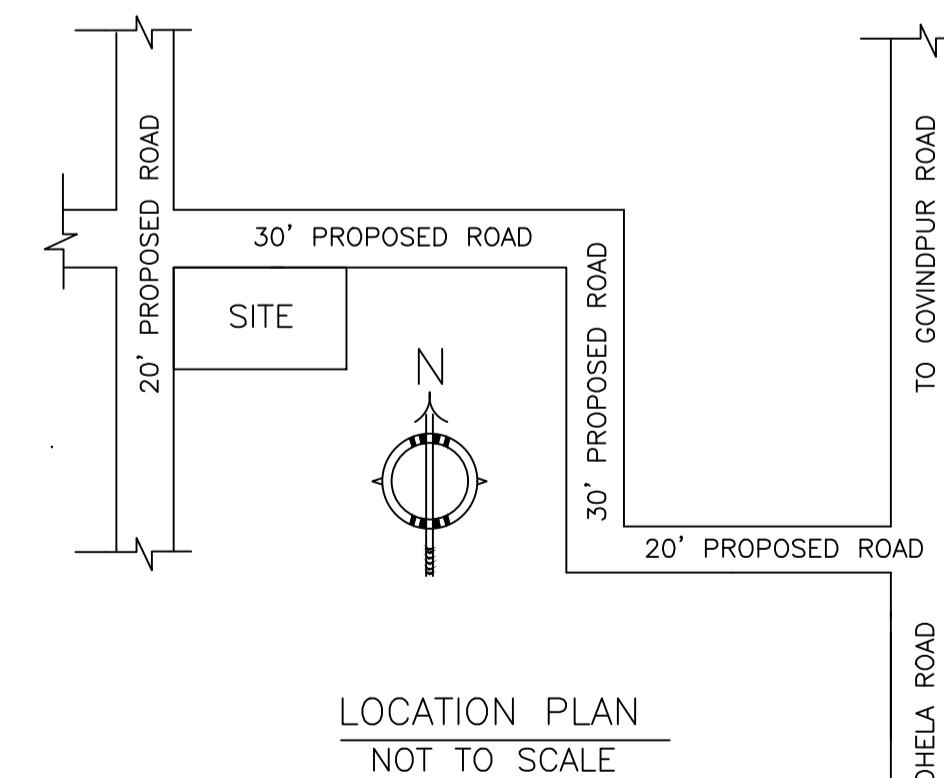
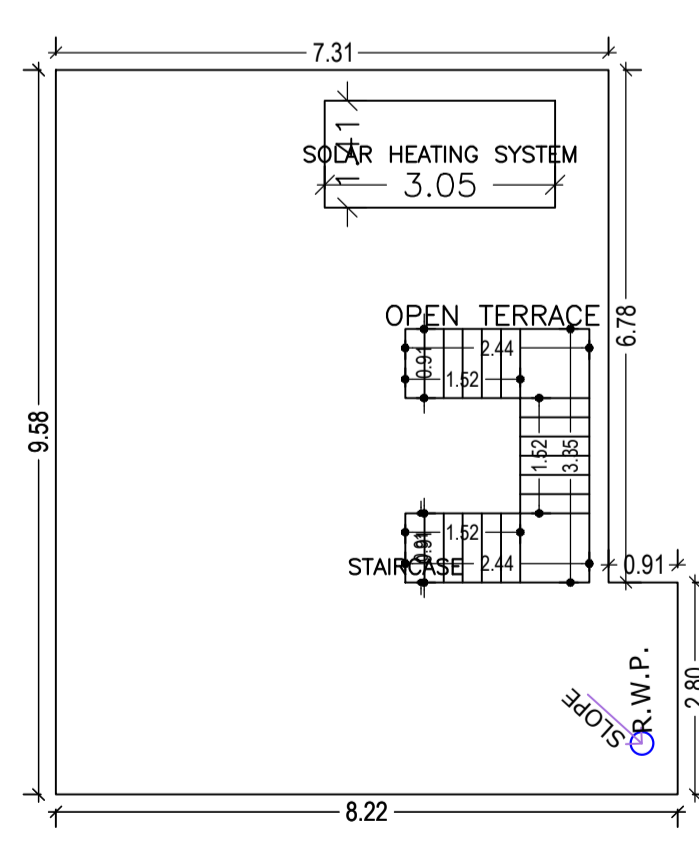
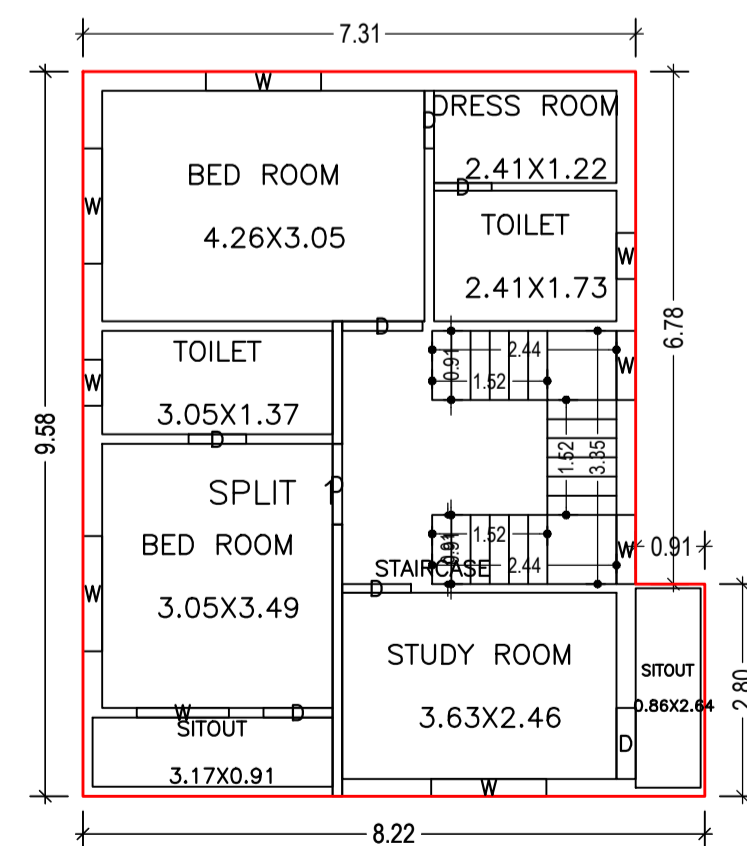
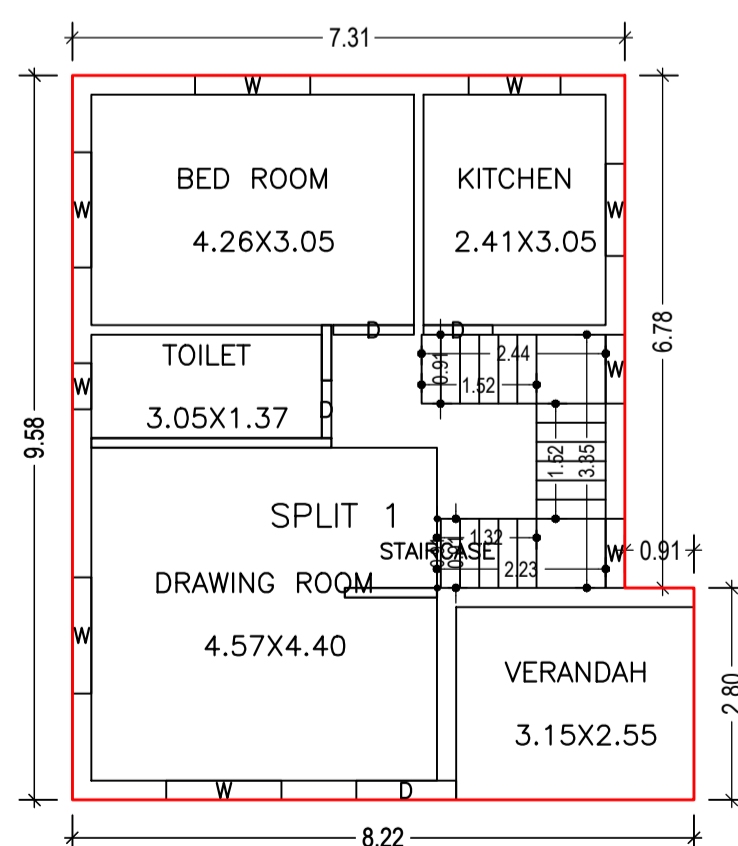
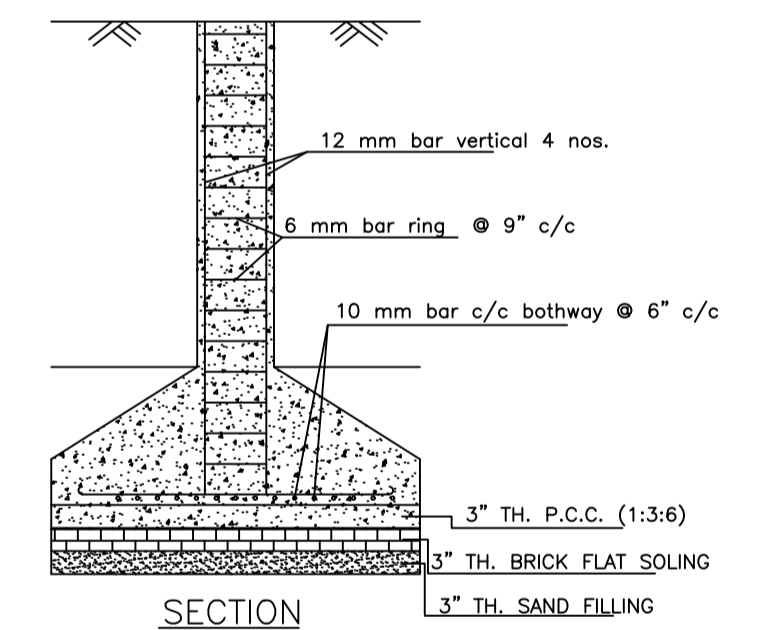
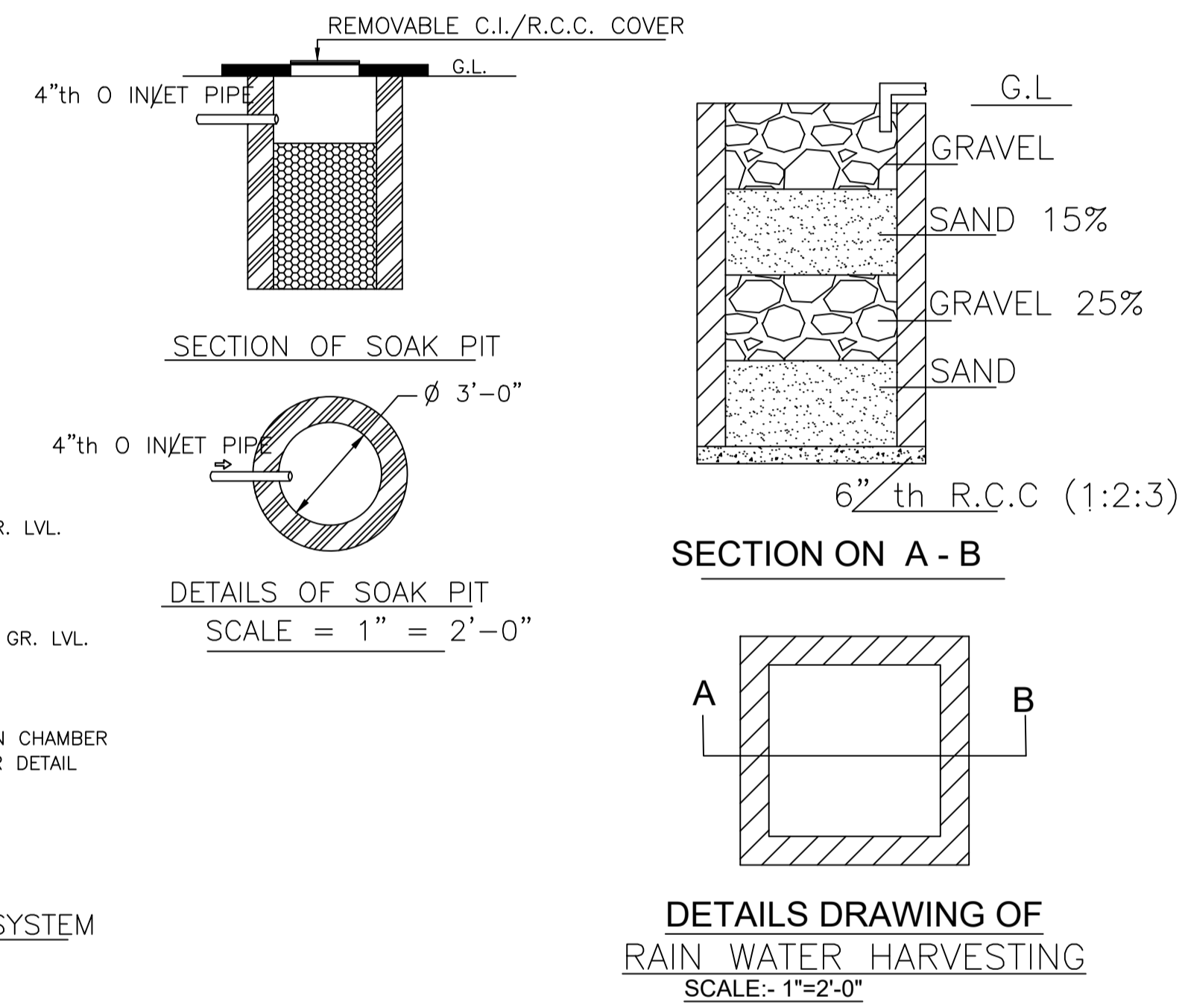
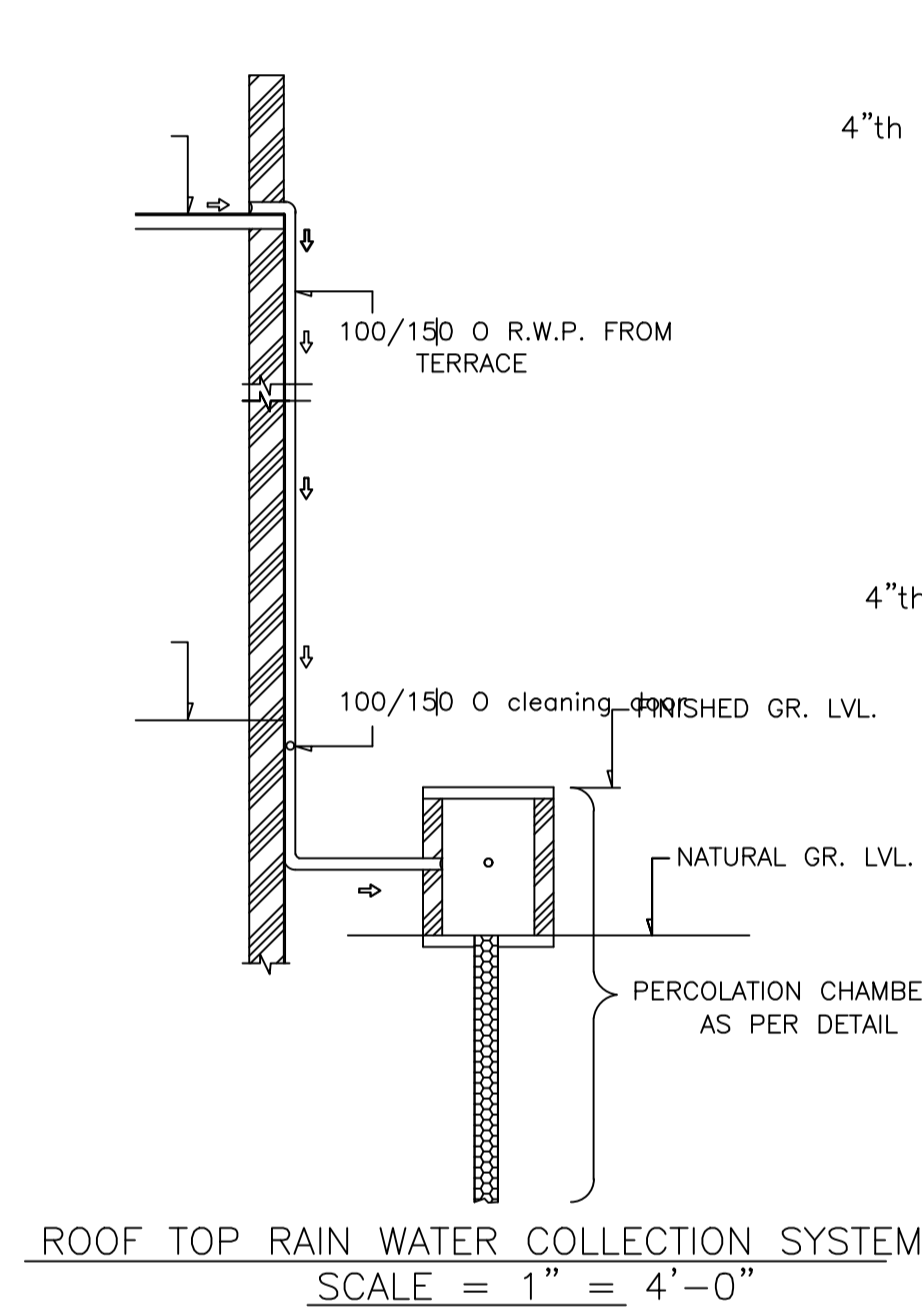
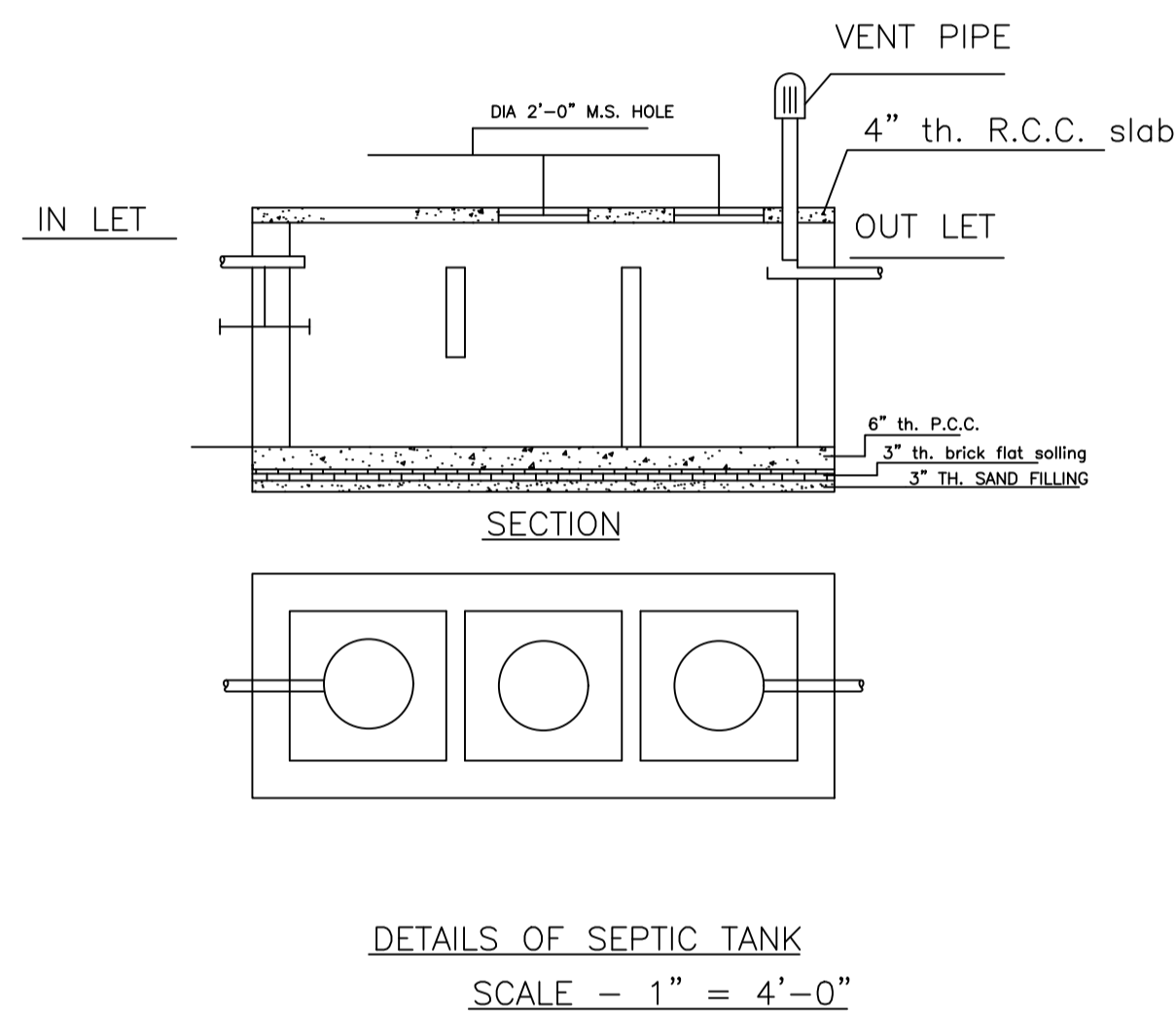
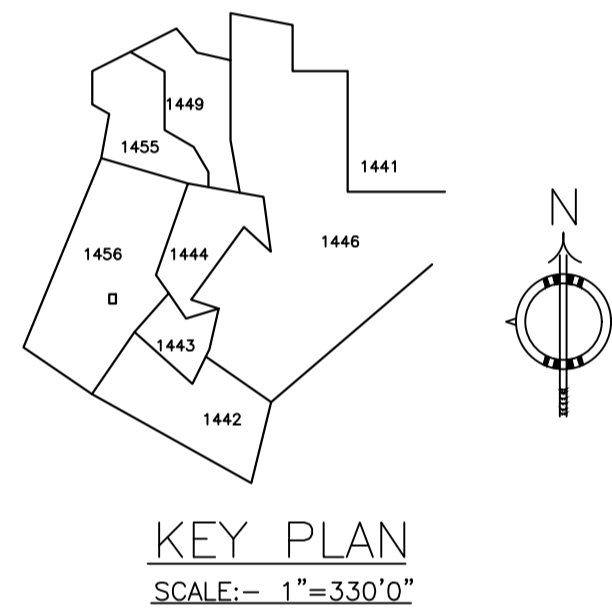
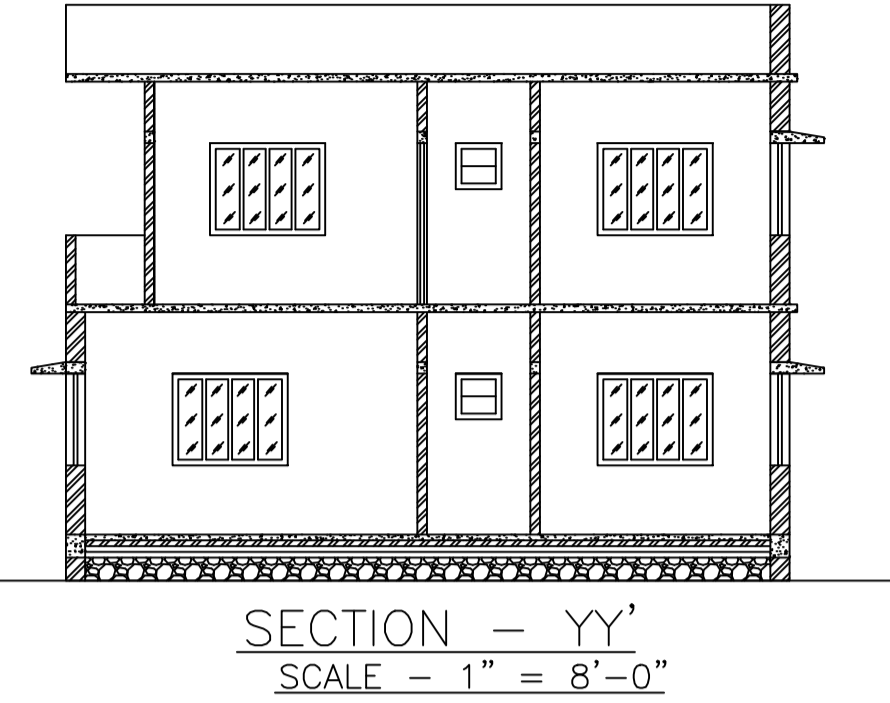
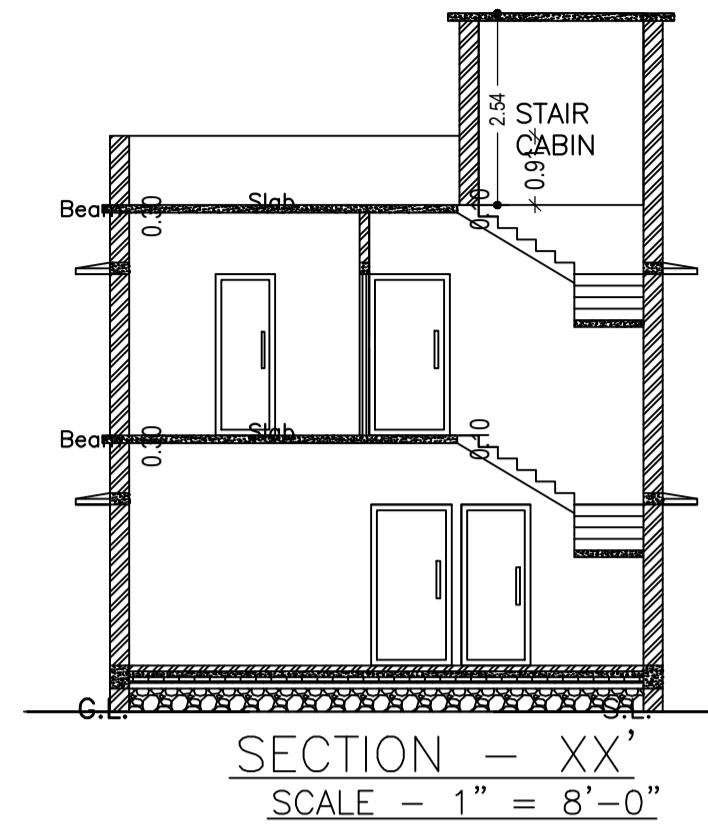
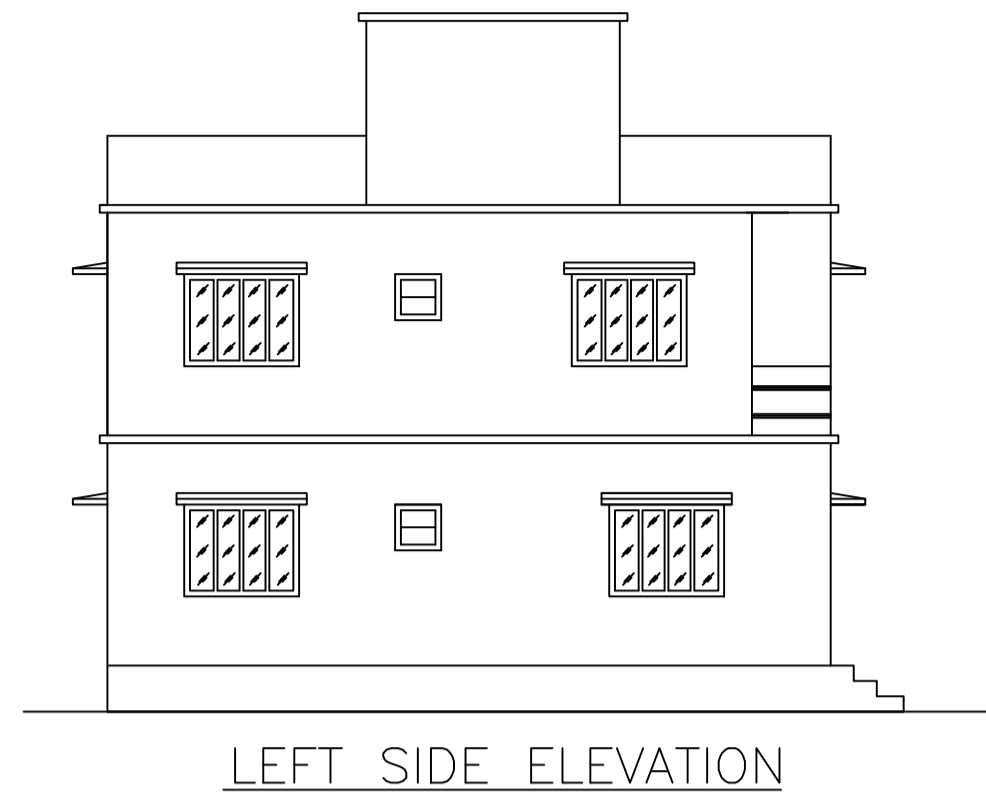
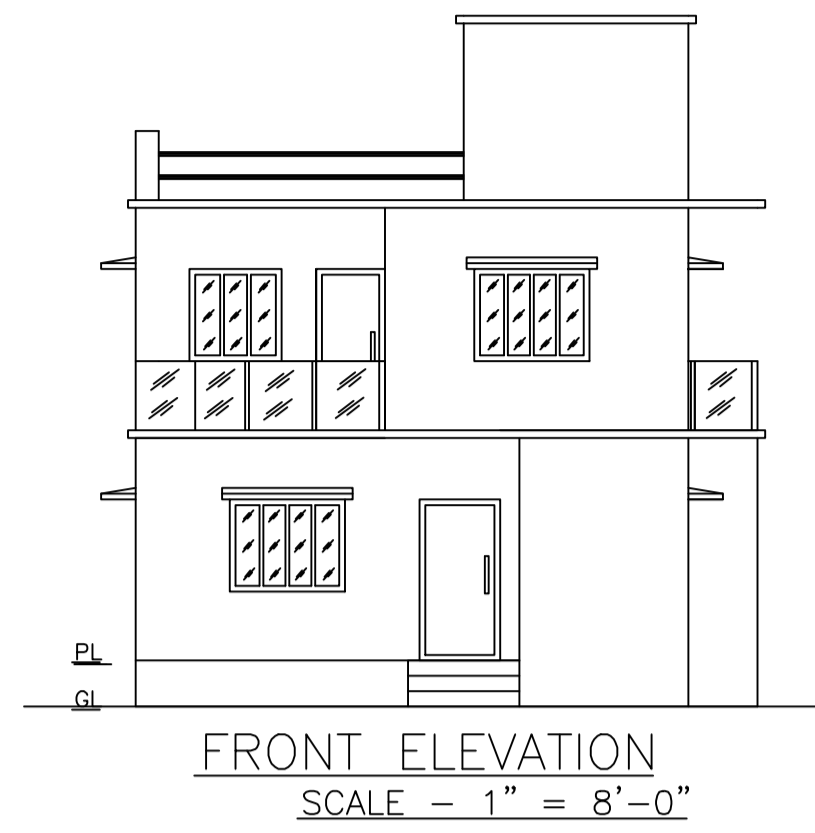

LTP NAME AND SIGNATURE	STRUCTURAL ENG'S NAME AND SIGNATURE	BUILDER NAME AND SIGNATURE	DIGITAL SIGNATURE
RAM PRATAP SINGH MADA/ARC/0024/2019			