

Proposal Basic Information

Proposal File No.	MADA/BP/0227/2021
Owner Name	1. SRI. RAJ KUMAR MALLAH AND 2. SMT. RAJ KUMARI DEVI
Khata No	OLD KHATA NO-36, NEW KHATA NO-350
Plot No	OLD PLOT NO. 2539, NEW PLOT NO. 3965
Village Name	Bara Pichri
Use	Residential
SubUse	Bungalow/ Dwelling / Non Apartment

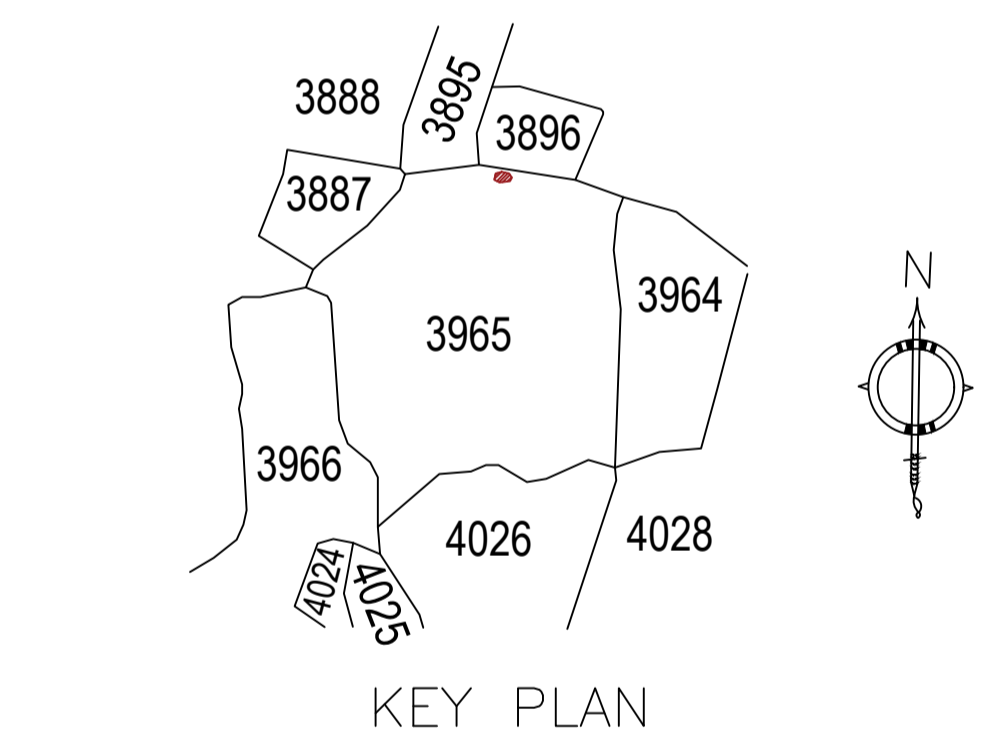
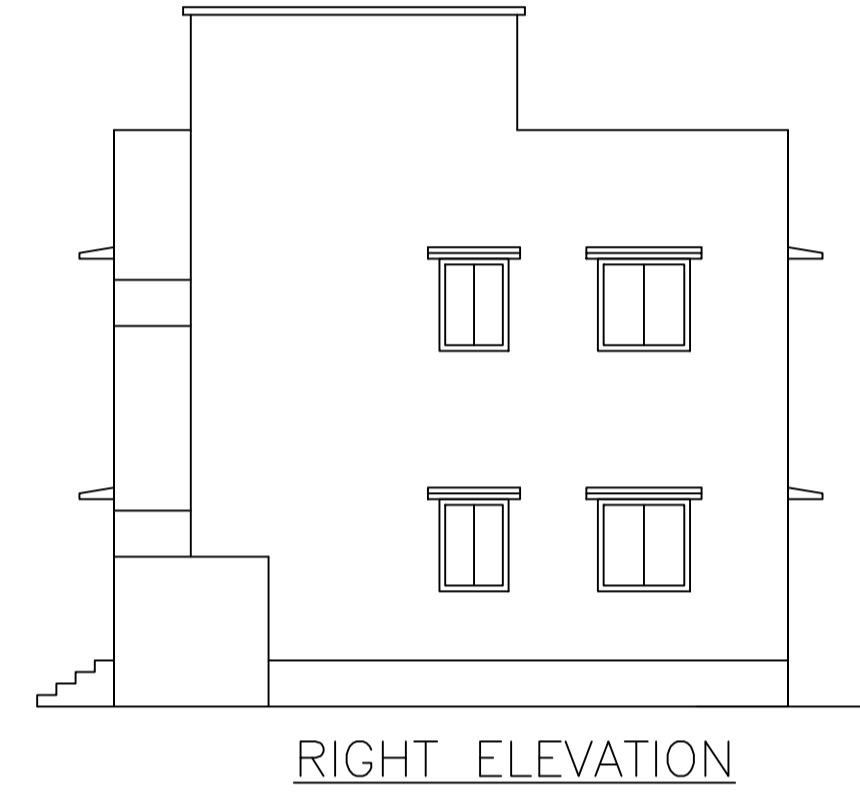
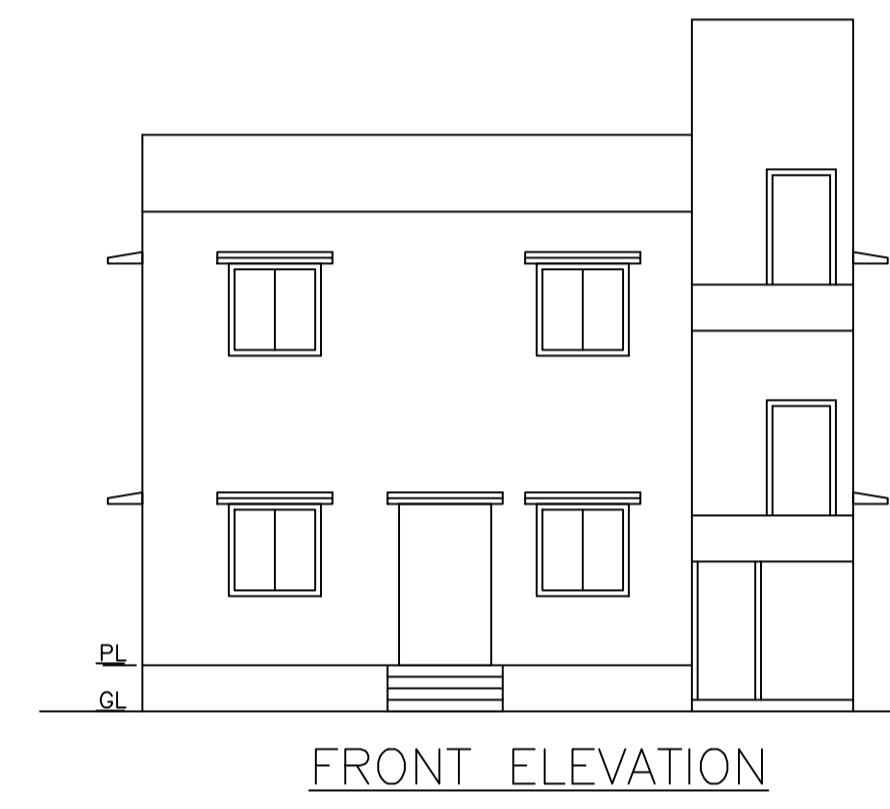
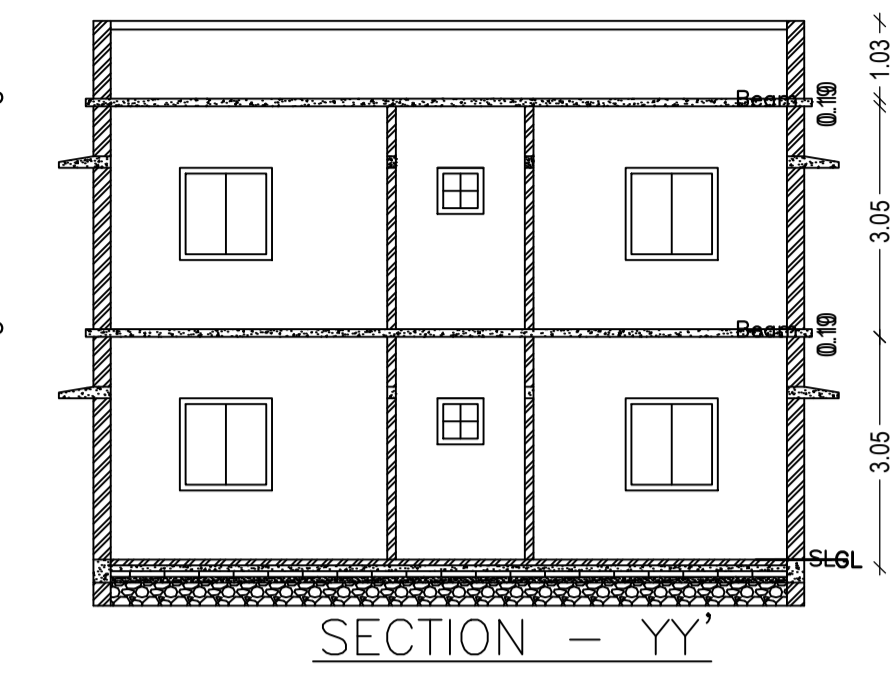
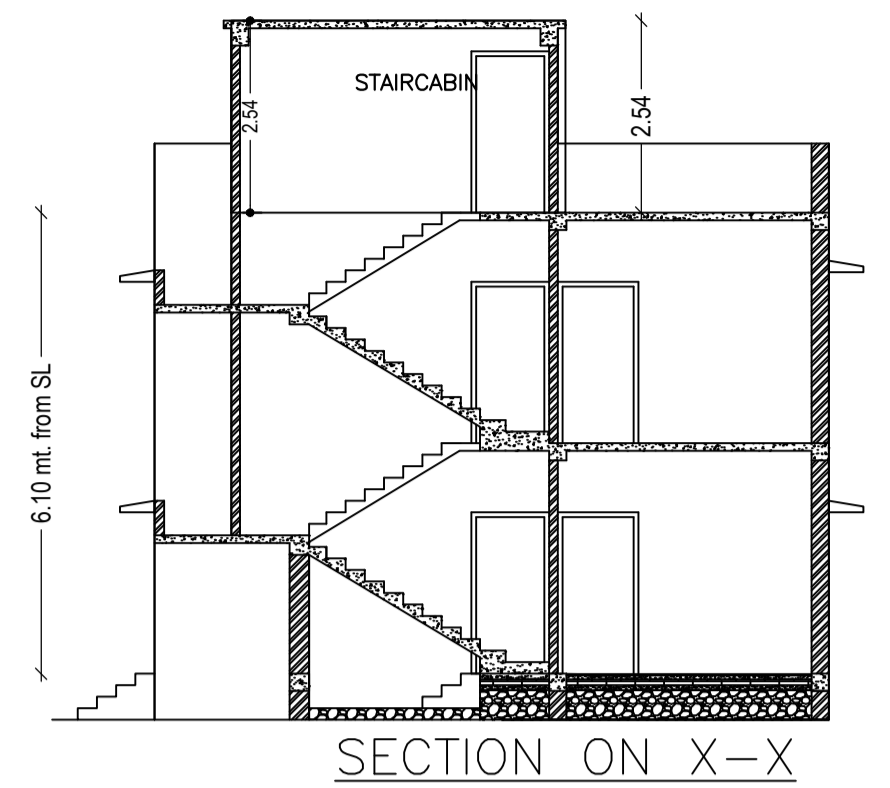
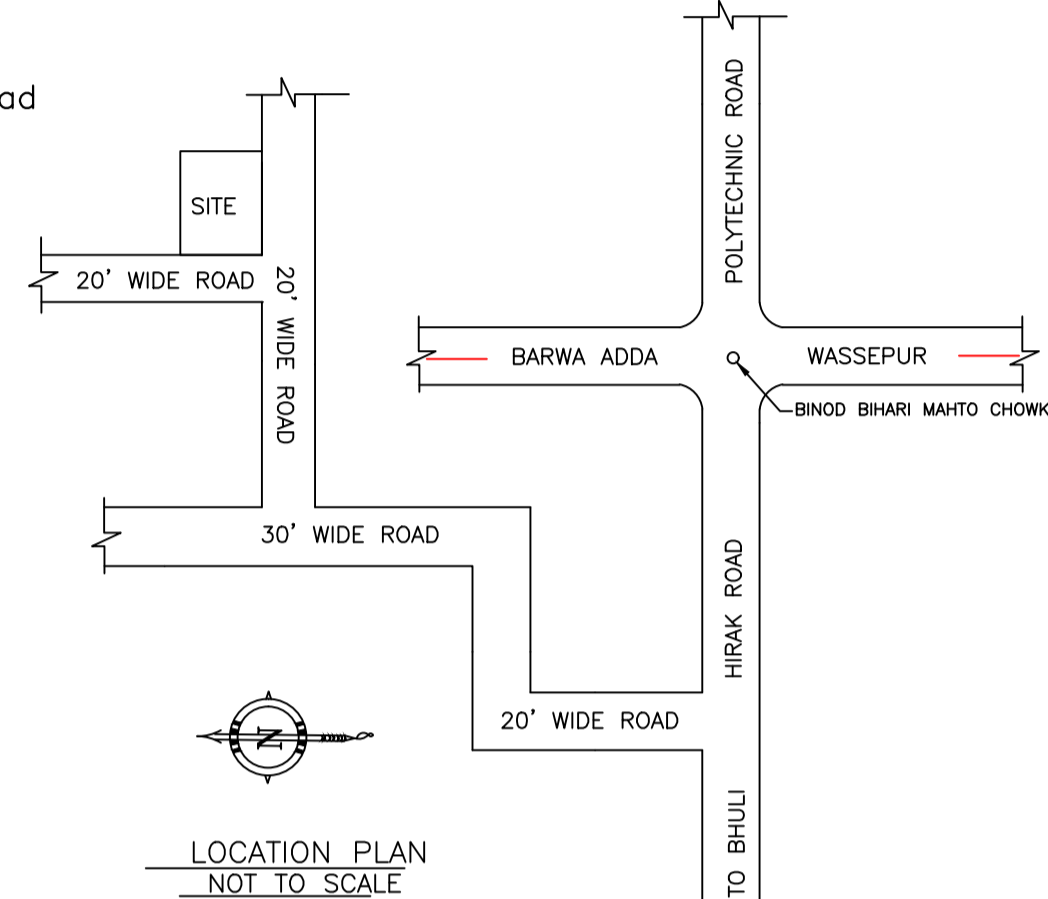
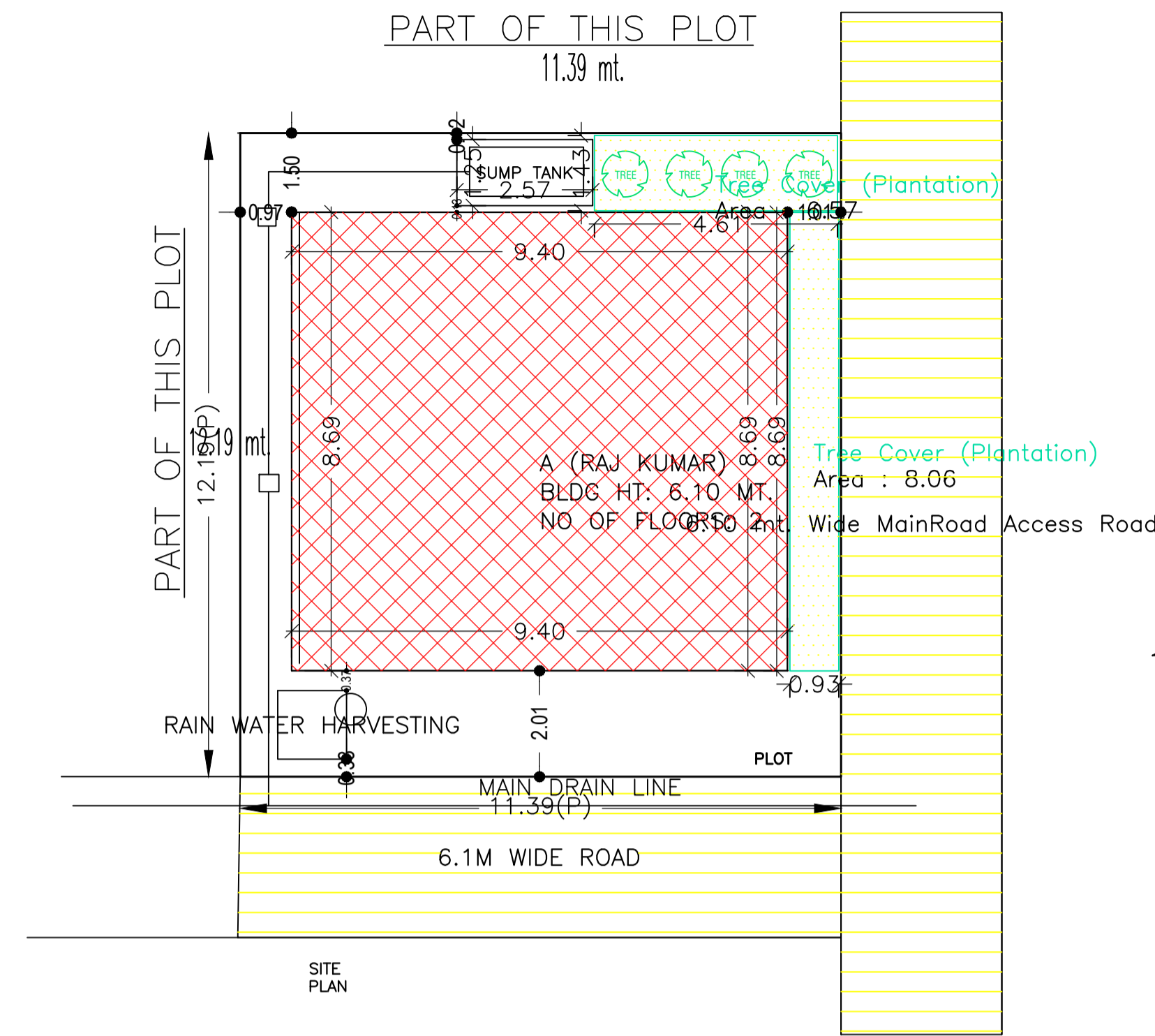

AREA STATEMENT MINERAL AREA DEVELOPMENT AUTHORITY	REGION NO.: 1.0.60	VERSION DATE: 16/10/2020
PROJECT DETAIL:	Region: JHARKHAND URBAN LOCAL BODIES	Plot Use: Residential
	District: DHANBAD	Plot SubUse: Bungalow/ Dwelling / Non Apartment
	Authority: MINERAL AREA DEVELOPMENT AUTHORITY	Plot/ReligiousStructure: NA
	Inward No: MADA/BP/0227/2021	Plot/SubPlot No: OLD PLOT NO. 2539, NEW PLOT NO. 3965
	Application Type: General Proposal	North: Plot No. - SAME PLOT
	Project Type: Building Permission	South: Road Width - 6.10
	Nature of Development: New	East: Plot No. - SAME PLOT
	Location of Development Area: Old Area	West: Road Width - 6.10
AREA DETAILS:		SQ.MT.
AREA OF PLOT (Minimum)	(A)	138.85
NET AREA OF PLOT (Gross Plot Area - Deduction from Gross Plot area)	(A-Deductions)	138.85
Deduction for Balance Plot Area (from Gross Plot Area)		
Common Plot		14.63
Total		14.63
BALANCE AREA OF PLOT (Net Plot Area - Recreational/Amenity space)	(A-Deductions)	124.22
PLOT AREA FOR COVERAGE (Net Plot Area)	(A-Deductions)	138.85
Plot Area for FAR (Net Plot Area + Road Widening Area)	(A-Deductions)	138.85
COVERAGE CHECK		
Permissible Coverage area ( 70.00 % )		97.19
Proposed Coverage Area ( 58.83 % )		81.68
Total Prop. Coverage Area ( 58.83 % )		81.68
Balance coverage area ( 11.17 % )		15.51
FAR CHECK		
Perm. FAR Area ( 2.50 )		347.13
Total Perm. FAR area		347.13
Residential FAR		163.36
Proposed FAR Area		163.36
Total Proposed FAR Area		163.36
Consumed FAR (Factor)		1.18
Balance FAR Area		183.77
BUILT UP AREA CHECK		
Total Proposed BuiltUp Area		164.52
ARCHITECT (Regd)	RAM PRATAP SINGH	
ENGINEER (Regd)		
SUPERVISOR (Regd)		
OWNER (Regd)	1. SRI. RAJ KUMAR MALLAH AND 2. SMT. RAJ KUMARI DEVI	
DEVELOPMENT AUTHORITY		LOCAL BODY

COLOR INDEX	
PLOT BOUNDARY	Black
ABUTTING ROAD	Green
PROPOSED CONSTRUCTION	Red
COMMON PLOT	Yellow
ROAD WIDENING AREA	Orange
EXISTING (To be retained)	Blue
EXISTING (To be demolished)	Light Blue

SCHEDULE OF DOOR:

BUILDING NAME	NAME	LENGTH	HEIGHT	NOS
A (RAJ KUMAR)	D	0.76	2.10	02
A (RAJ KUMAR)	D	0.90	2.10	06
A (RAJ KUMAR)	D	0.91	2.10	03
A (RAJ KUMAR)	D	1.03	2.10	02
A (RAJ KUMAR)	D	1.22	2.10	01

SCHEDULE OF WINDOW/VENTILATION:

BUILDING NAME	NAME	LENGTH	HEIGHT	NOS
A (RAJ KUMAR)	W	0.61	1.20	02
A (RAJ KUMAR)	W	0.91	1.20	04
A (RAJ KUMAR)	W	1.22	1.20	12
A (RAJ KUMAR)	W	1.80	1.20	02
A (RAJ KUMAR)	W	1.82	1.20	01
A (RAJ KUMAR)	W	2.43	1.20	01

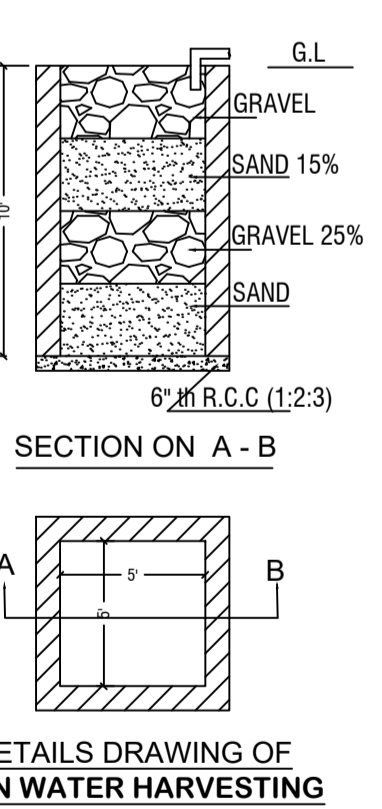
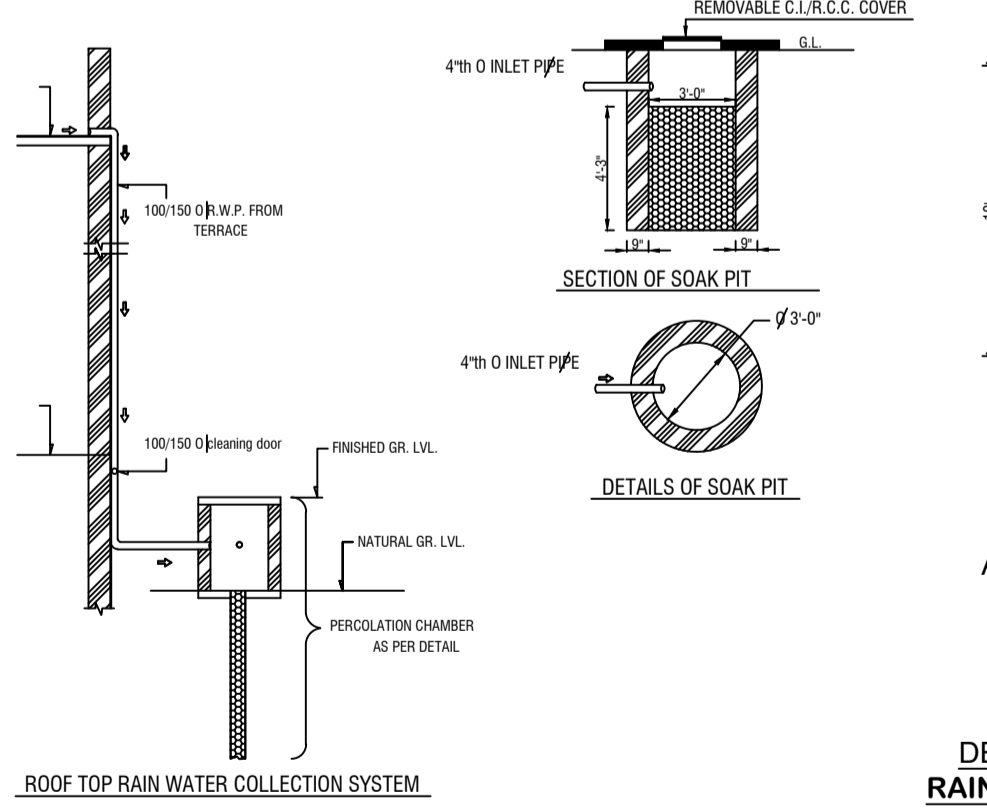
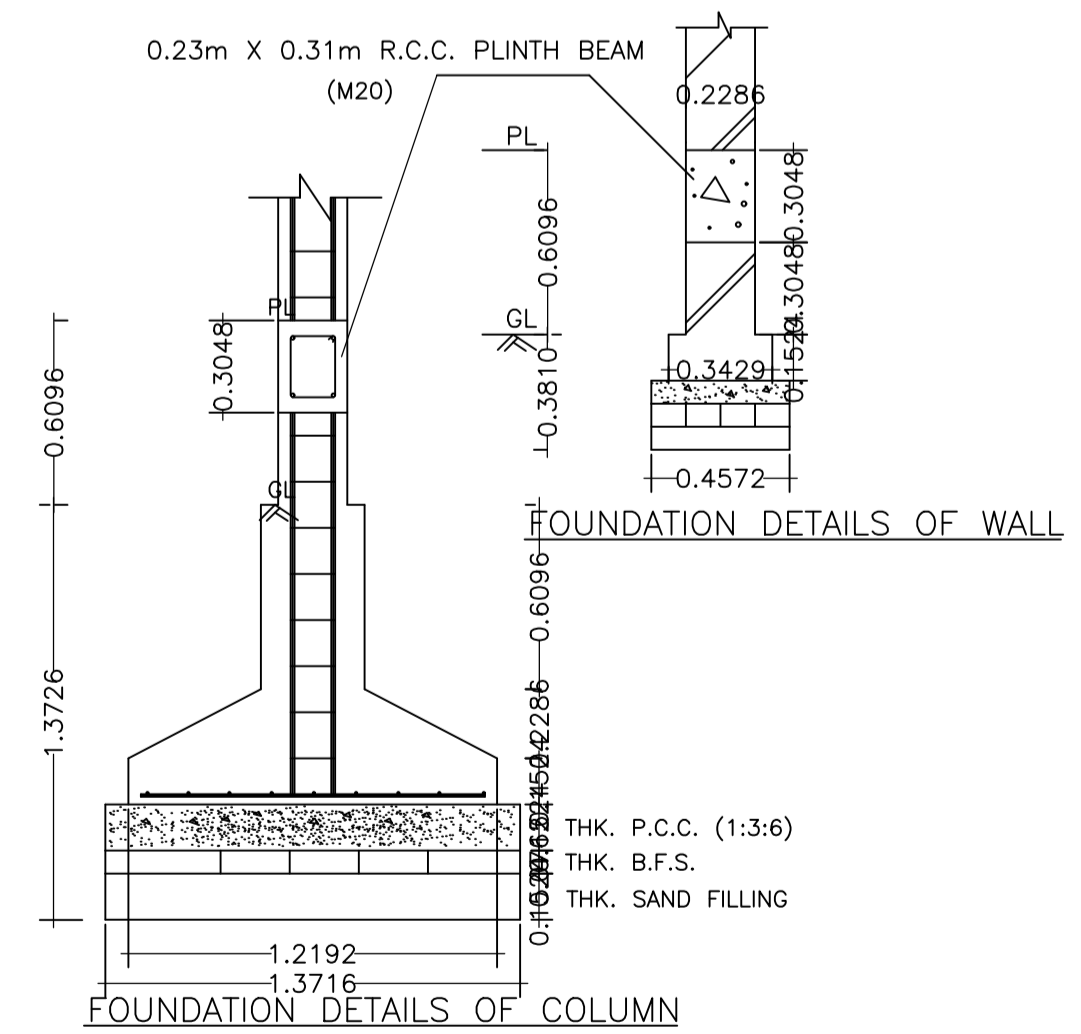
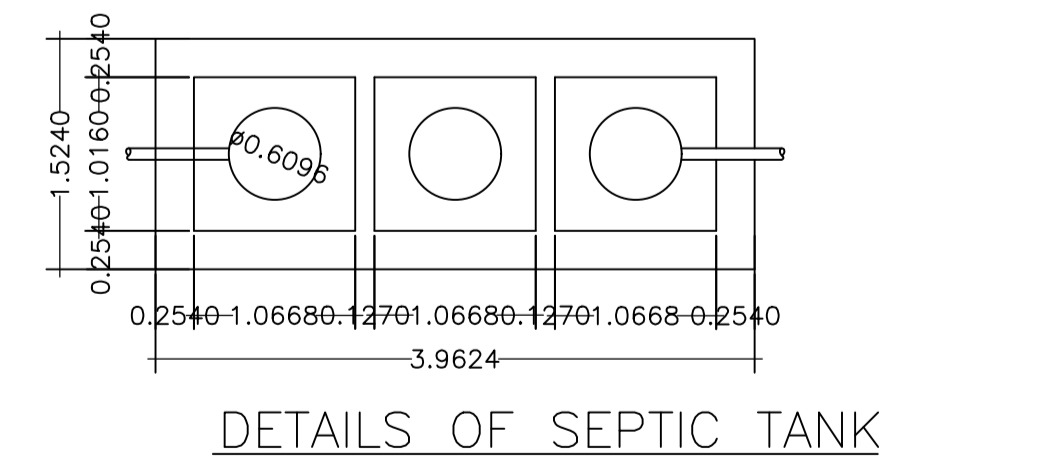
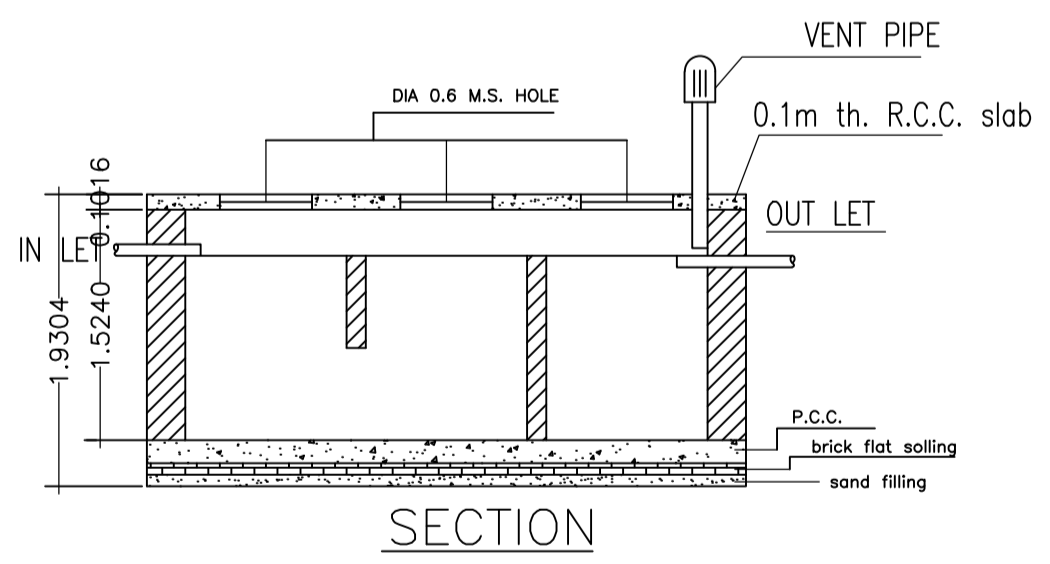

Buildingwise Floor FAR Details

Floor Name	Building Name A (RAJ KUMAR)		Total	
	Proposed Built Up Area (Sq.mt.)	Proposed FAR Area (Sq.mt.)	Total Proposed Built Up Area (Sq.mt.)	Total FAR Area (Sq.mt.)
Ground Floor	82.84	81.68	82.84	81.68
First Floor	81.68	81.68	81.68	81.68
Terrace Floor	0.00	0.00	0.00	0.00
Total :	164.52	163.36	164.52	163.36

Building USE/SUBUSE Details

Building Name	Building Use	Building SubUse	Building Structure
A (RAJ KUMAR)	Residential	Bungalow/ Dwelling / Non Apartment	Non-Highrise

UnitBUA Table for Building :A (RAJ KUMAR)

FLOOR	Name	UnitBUA Type	UnitBUA Area	Carpet Area	No. of Rooms	No. of Tenement
GROUND FLOOR PLAN	SPLIT 1	FLAT	163.36	161.44	6	1
FIRST FLOOR PLAN	SPLIT 1	FLAT	0.00	0.00	7	0
Total:	-	-	163.36	161.44	13	1

FAR & Tenement Details (Table 4c-1)

Building	No. of Same Bldg	Total Built Up Area (Sq.mt.)	Deductions (Area in Sq.mt.)	Proposed FAR Area (Sq.mt.)		Total FAR Area (Sq.mt.)	Total Consumed Additional FAR Area (Sq.mt.)	Trmt (No.)
				StairCase	Resi.			
A (RAJ KUMAR)	1	164.52	1.16	163.36	163.36	163.36	163.36	01
Grand Total :	1	164.52	1.16	163.36	163.36	163.36	163.36	01

Building :A (RAJ KUMAR)

Floor Name	Total Built Up Area (Sq.mt.)	Deductions (Area in Sq.mt.)	Proposed FAR Area (Sq.mt.)		Total Consumed Additional FAR Area (Sq.mt.)	Trmt (No.)
			StairCase	Resi.		
Ground Floor	82.84	1.16	81.68	81.68	81.68	01
First Floor	81.68	0.00	81.68	81.68	81.68	00
Terrace Floor	0.00	0.00	0.00	0.00	0.00	00
Total :	164.52	1.16	163.36	163.36	163.36	01
Total Number of Same Buildings	1					
Total :	164.52	1.16	163.36	163.36	163.36	01

LTP NAME AND SIGNATURE	STRUCTURAL ENG'S NAME AND SIGNATURE	BUILDER NAME AND SIGNATURE	DIGITAL SIGNATURE
RAM PRATAP SINGH MADA/ARC/0024/2019			

