

WATER HARVESTING Scale 1" = 4' 0"
ROOF TOP RAIN WATER COLLECTION SYSTEM

SITE PLAN 1"=8' SITE PLAN

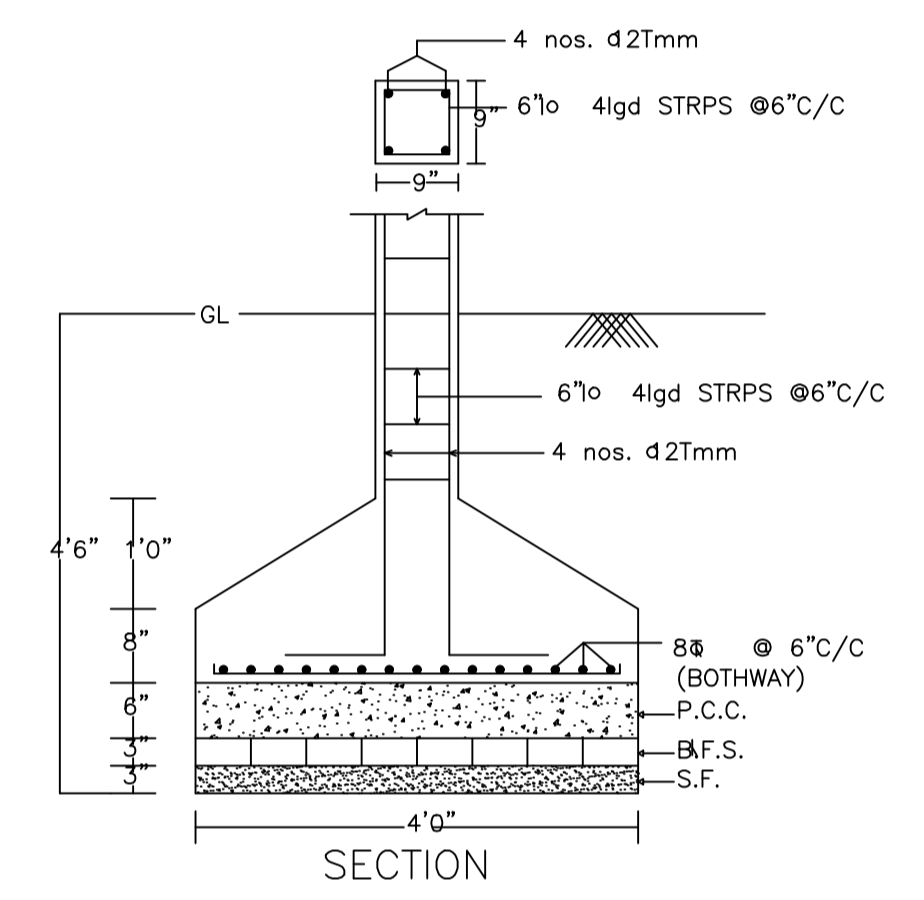

DETAIL OF COLUMNS



FAR & Tenement Details (Table 4c-1)

Building	No. of Same Bldg	Total Built Up Area (Sq.mt.)	Proposed FAR Area (Sq.mt.)	Total FAR Area (Sq.mt.)	Total Consumed Additional FAR Area (Sq.mt.)	Tnmt (No.)
A (1 SRI RAMIT KUMAR GUPTA, 2 SRI AJAY KUMAR GUPTA, 3 SRI SURESH KUMAR GUPTA)	1	404.40	404.40	404.40	404.40	01
Grand Total :	1	404.40	404.40	404.40	404.40	01

UnitBUA Table for Building :A (1 SRI RAMIT KUMAR GUPTA, 2 SRI AJAY KUMAR GUPTA, 3 SRI SURESH KUMAR GUPTA)

FLOOR	Name	UnitBUA Type	UnitBUA Area	Carpet Area	No. of Rooms	No. of Tenement
GROUND FLOOR PLAN	SPLIT A	FLAT	404.38	404.14	8	1
TYPICAL -1, 2, 3 FLOOR PLAN	SPLIT A	FLAT	0.00	0.00	8	0
Total:			404.38	404.14	32	1

Building :A (1 SRI RAMIT KUMAR GUPTA, 2 SRI AJAY KUMAR GUPTA, 3 SRI SURESH KUMAR GUPTA)

Floor Name	Total Built Up Area (Sq.mt.)	Proposed FAR Area (Sq.mt.)	Total FAR Area (Sq.mt.)	Total Consumed Additional FAR Area (Sq.mt.)	Tnmt (No.)
Ground Floor	101.10	101.10	101.10	101.10	01
First Floor	101.10	101.10	101.10	101.10	00
Second Floor	101.10	101.10	101.10	101.10	00
Third Floor	101.10	101.10	101.10	101.10	00
Terrace Floor	0.00	0.00	0.00	0.00	00
Total :	404.40	404.40	404.40	404.40	01
Total Number of Same Buildings :	1				01

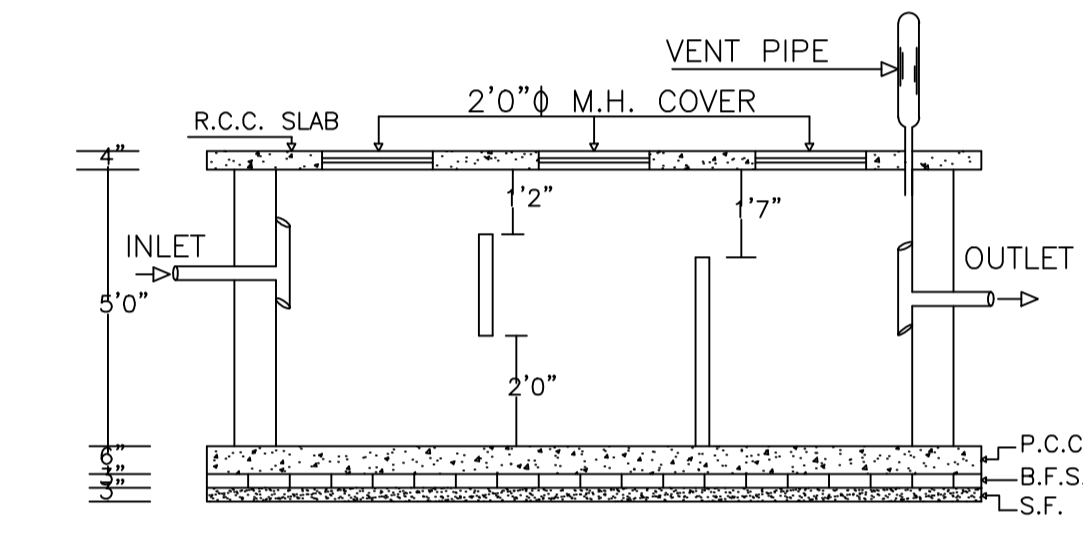

PLAN OF SEPTIC TANK SCALE:- 1" = 4' - 0"

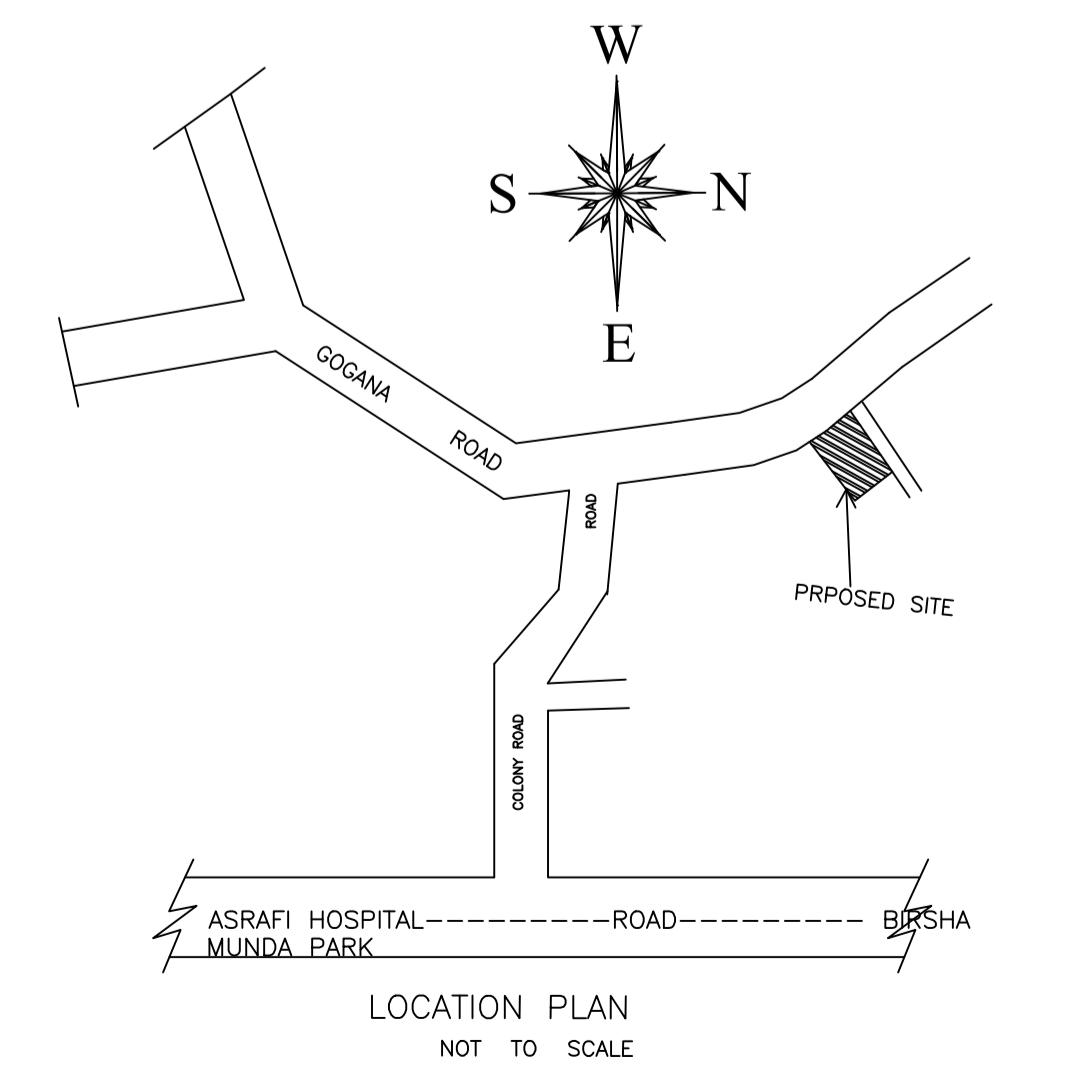

LOCATION PLAN NOT TO SCALE

SCHEDULE OF DOOR:

BUILDING NAME	NAME	LENGTH	HEIGHT	NOS
A (1 SRI RAMIT KUMAR GUPTA, 2 SRI AJAY KUMAR GUPTA, 3 SRI SURESH KUMAR GUPTA)	D	0.71	2.10	04
A (1 SRI RAMIT KUMAR GUPTA, 2 SRI AJAY KUMAR GUPTA, 3 SRI SURESH KUMAR GUPTA)	D	0.76	2.10	04
A (1 SRI RAMIT KUMAR GUPTA, 2 SRI AJAY KUMAR GUPTA, 3 SRI SURESH KUMAR GUPTA)	D	0.88	2.10	04
A (1 SRI RAMIT KUMAR GUPTA, 2 SRI AJAY KUMAR GUPTA, 3 SRI SURESH KUMAR GUPTA)	D	0.94	2.10	04
A (1 SRI RAMIT KUMAR GUPTA, 2 SRI AJAY KUMAR GUPTA, 3 SRI SURESH KUMAR GUPTA)	D	0.99	2.10	08
A (1 SRI RAMIT KUMAR GUPTA, 2 SRI AJAY KUMAR GUPTA, 3 SRI SURESH KUMAR GUPTA)	D	1.07	2.10	08

SCHEDULE OF WINDOW/VENTILATION:

BUILDING NAME	NAME	LENGTH	HEIGHT	NOS
A (1 SRI RAMIT KUMAR GUPTA, 2 SRI AJAY KUMAR GUPTA, 3 SRI SURESH KUMAR GUPTA)	W	0.73	1.20	04
A (1 SRI RAMIT KUMAR GUPTA, 2 SRI AJAY KUMAR GUPTA, 3 SRI SURESH KUMAR GUPTA)	W	0.75	1.20	04
A (1 SRI RAMIT KUMAR GUPTA, 2 SRI AJAY KUMAR GUPTA, 3 SRI SURESH KUMAR GUPTA)	W	1.20	1.20	04
A (1 SRI RAMIT KUMAR GUPTA, 2 SRI AJAY KUMAR GUPTA, 3 SRI SURESH KUMAR GUPTA)	W	1.54	1.20	04
A (1 SRI RAMIT KUMAR GUPTA, 2 SRI AJAY KUMAR GUPTA, 3 SRI SURESH KUMAR GUPTA)	W	1.92	1.20	04
A (1 SRI RAMIT KUMAR GUPTA, 2 SRI AJAY KUMAR GUPTA, 3 SRI SURESH KUMAR GUPTA)	W	2.11	1.20	04
A (1 SRI RAMIT KUMAR GUPTA, 2 SRI AJAY KUMAR GUPTA, 3 SRI SURESH KUMAR GUPTA)	W	2.13	1.20	04
A (1 SRI RAMIT KUMAR GUPTA, 2 SRI AJAY KUMAR GUPTA, 3 SRI SURESH KUMAR GUPTA)	W	2.17	1.20	04
A (1 SRI RAMIT KUMAR GUPTA, 2 SRI AJAY KUMAR GUPTA, 3 SRI SURESH KUMAR GUPTA)	W	2.25	1.20	04
A (1 SRI RAMIT KUMAR GUPTA, 2 SRI AJAY KUMAR GUPTA, 3 SRI SURESH KUMAR GUPTA)	W	2.34	1.20	04
A (1 SRI RAMIT KUMAR GUPTA, 2 SRI AJAY KUMAR GUPTA, 3 SRI SURESH KUMAR GUPTA)	W	3.15	1.20	04

Proposal Basic Information

Proposal File No.	MADA/BP/0382/2021
Owner Name	1. SRI RAMIT KUMAR GUPTA, 2. SRI AJAY KUMAR GUPTA, 3. SRI SURESH KUMAR GUPTA
Khata No.	5, NEW- 97
Plot No.	932, NEW-727
Village Name	Nawadh
Use	Residential
SubUse	Bungalow/ Dwelling / Non Apartment

AREA STATEMENT MINERAL AREA DEVELOPMENT AUTHORITY

VERSION NO.:	1.0.62
VERSION DATE:	16/10/2020
PROJECT DETAIL:	
Region: JHARKHAND URBAN LOCAL BODIES	Plot Use: Residential
District: DHANBAD	Plot SubUse: Bungalow/ Dwelling / Non Apartment
Authority: MINERAL AREA DEVELOPMENT AUTHORITY	PlotNearby/ReligiousStructure: NA
Inward No: MADA/BP/0382/2021	Plot/SubPlot No: 932, NEW-727
Application Type: General Proposal	North: Plot No. - LOT NO. 49 (P)
Project Type: Building Permission	South: Plot No. - LOT NO. 50 (P)
Nature of Development: New	East: Plot No. - LOT NO. 5 AND 4
Location of Development Area: Old Area	West: Road Width - 7.01
AREA DETAILS:	
AREA OF PLOT (Minimum)	(A) 174.00
NET AREA OF PLOT(Gross Plot Area - Deduction from Gross Plot area)	(A-Deductions) 174.00
Deduction for Balance Plot Area(from Gross Plot Area)	
Common Plot Total	26.79
BALANCE AREA OF PLOT(Net Plot Area - Recreational/Amenity spaces)	(A-Deductions) 147.21
PLOT AREA FOR COVERAGE(Net Plot Area)	(A-Deductions) 174.00
Plot Area for FAR (Net Plot Area + RoadWidening Area)	(A-Deductions) 174.00
COVERAGE CHECK	
Permissible Coverage area (60.00 %)	104.40
Proposed Coverage Area (58.10 %)	101.10
Total Prop. Coverage Area (58.1 %)	101.10
Balance coverage area (1.90 %)	3.30
FAR CHECK	
Perm. FAR Area (2.50)	435.00
Total Perm. FAR area	435.00
Residential FAR	404.38
Proposed FAR Area	404.38
Total Proposed FAR Area	404.38
Consumed FAR (Factor)	2.32
Balance FAR Area	30.62
BUILT UP AREA CHECK	
Total Proposed BuiltUp Area	404.40
ARCHITECT (Regd)	RAJEEV RANJAN SINGH
ENGINEER (Regd)	
SUPERVISOR (Regd)	
OWNER (Regd)	1. SRI RAMIT KUMAR GUPTA, 2. SRI AJAY KUMAR GUPTA, 3. SRI SURESH KUMAR GUPTA
DEVELOPMENT AUTHORITY LOCAL BODY	

COLOR INDEX

PLOT BOUNDARY	Black
ABUTTING ROAD	Green
PROPOSED CONSTRUCTION	Red
COMMON PLOT	Yellow
ROAD WIDENING AREA	Blue
EXISTING (To be retained)	Light Blue
EXISTING (To be demolished)	Dark Blue

Buildingwise Floor FAR Details

Floor Name	Building Name		Total	
	Proposed Built Up Area (Sq.mt.)	Proposed FAR Area (Sq.mt.)	Total Proposed Built Up Area (Sq.mt.)	Total FAR Area (Sq.mt.)
Ground Floor	101.10	101.10	101.10	101.10
First Floor	101.10	101.10	101.10	101.10
Second Floor	101.10	101.10	101.10	101.10
Third Floor	101.10	101.10	101.10	101.10
Terrace Floor	0.00	0.00	0.00	0.00
Total :	404.40	404.40	404.40	404.40

Building USE/SUBUSE Details

Building Name	Building Use	Building SubUse	Building Structure
A (1 SRI RAMIT KUMAR GUPTA, 2 SRI AJAY KUMAR GUPTA, 3 SRI SURESH KUMAR GUPTA)	Residential	Residential Bldg/Apartment	Non-Highrise

LTP NAME AND SIGNATURE RAJEEV RANJAN SINGH MADA/ENG/0004/2019	STRUCTURAL ENG'S NAME AND SIGNATURE	BUILDER NAME AND SIGNATURE	DIGITAL SIGNATURE
---	-------------------------------------	----------------------------	-------------------

Proposal Basic Information	
Proposal File No.	MADA/BP/0382/2021
Owner Name	1. SRI RAMIT KUMAR GUPTA, 2. SRI AJAY KUMAR GUPTA, 3. SRI SURESH KUMAR GUPTA
Khata No	5, NEW- 97
Plot No	932, NEW-727
Village Name	Nawadhi
Use	Residential
SubUse	Bungalow/ Dwelling / Non Apartment

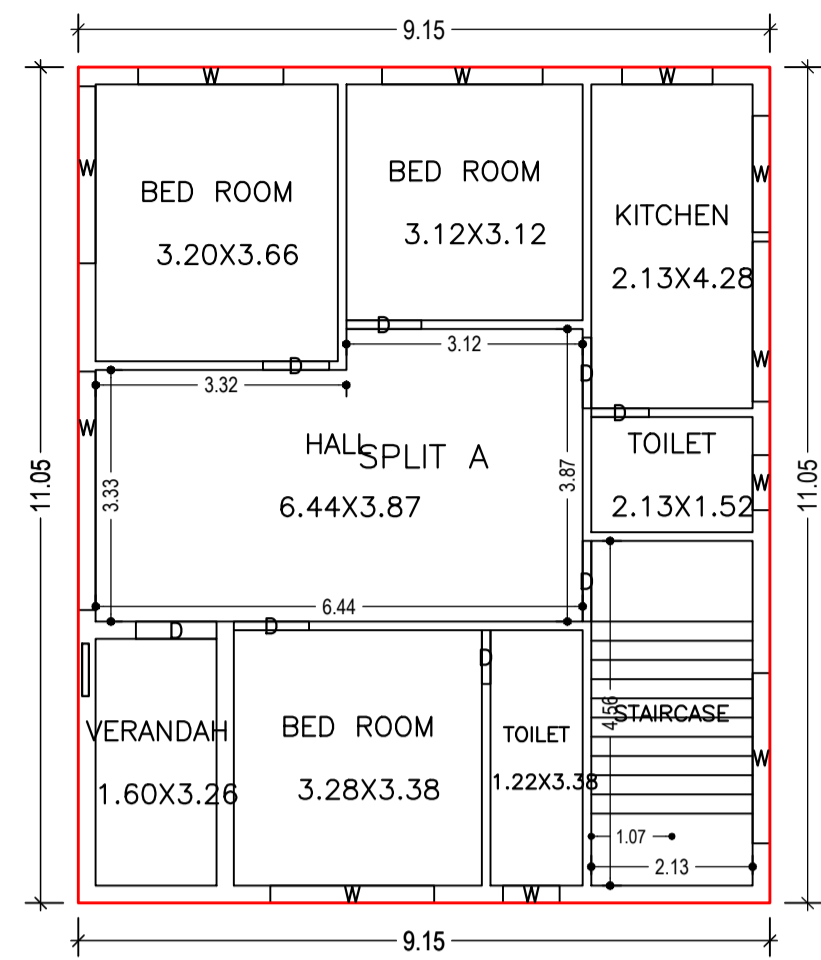

GROUND FLOOR PLAN
(Proposed)
(SCALE 1:100)

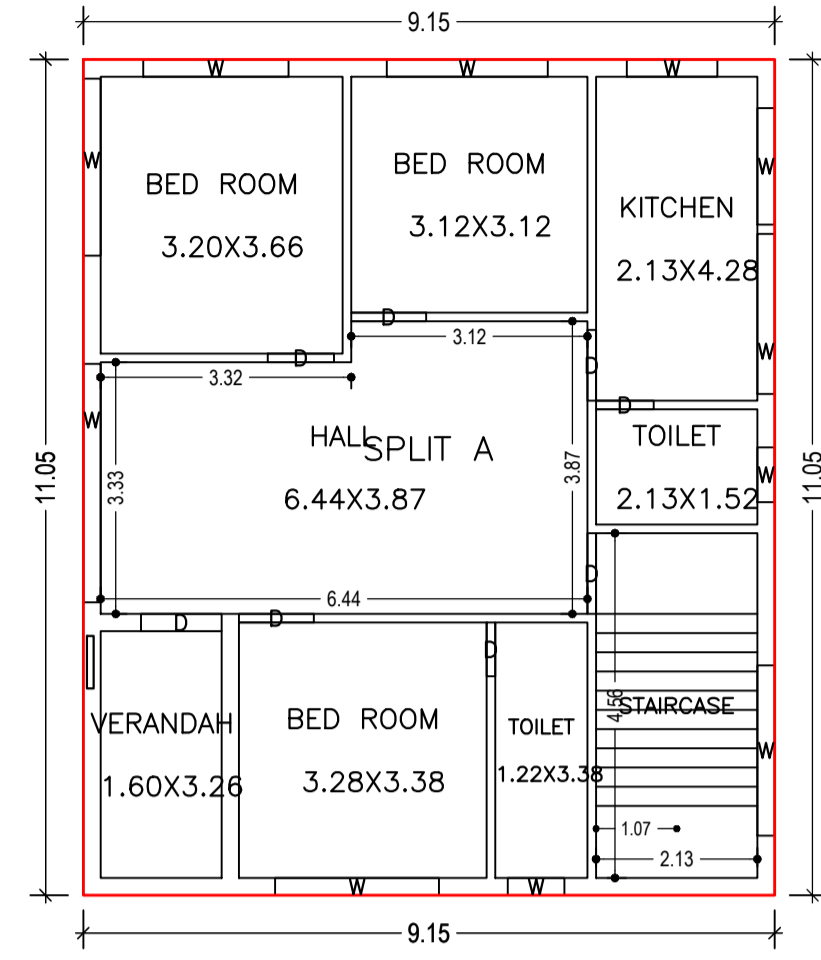

TYPICAL - 1, 2, 3 FLOOR PLAN
(Proposed)
(SCALE 1:100)

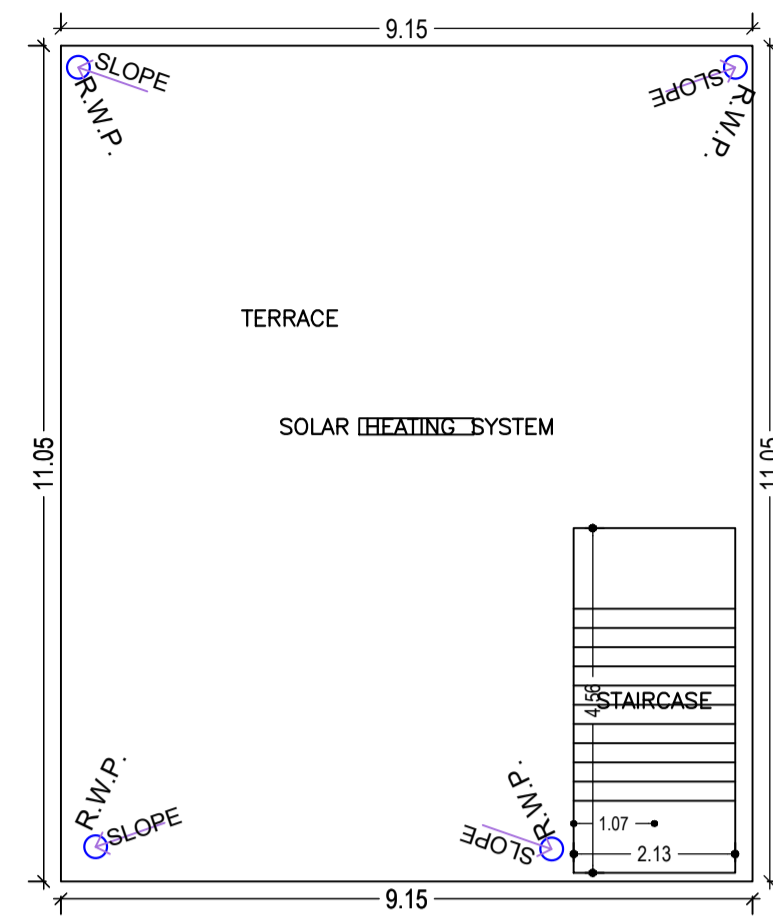

TERRACE FLOOR PLAN
(SCALE 1:100)

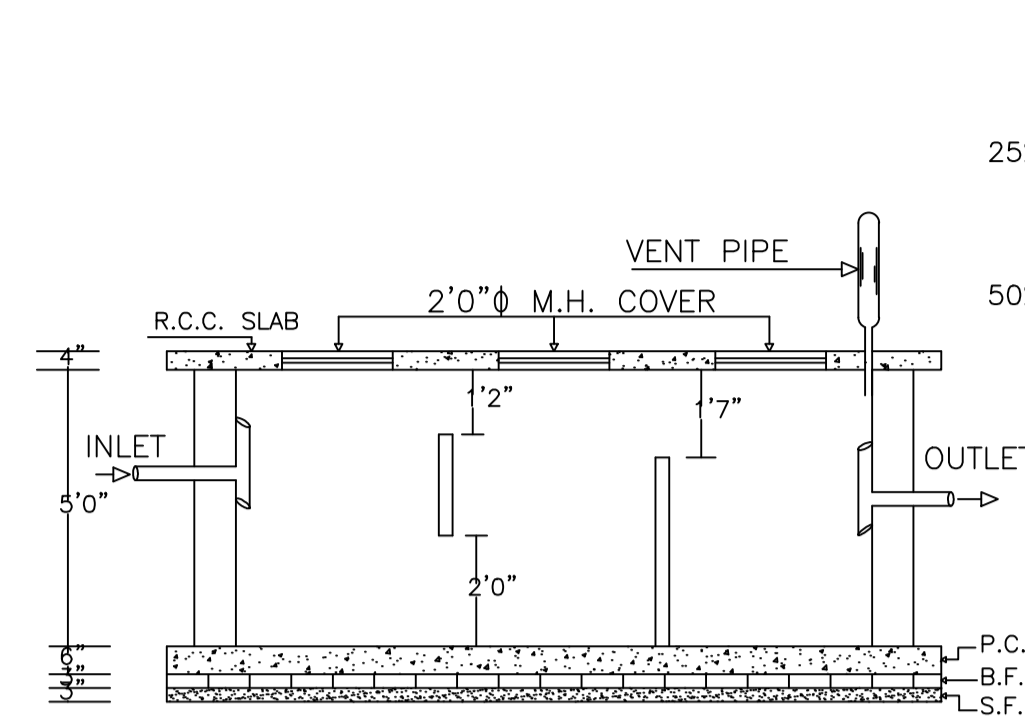

Section at Y-Y

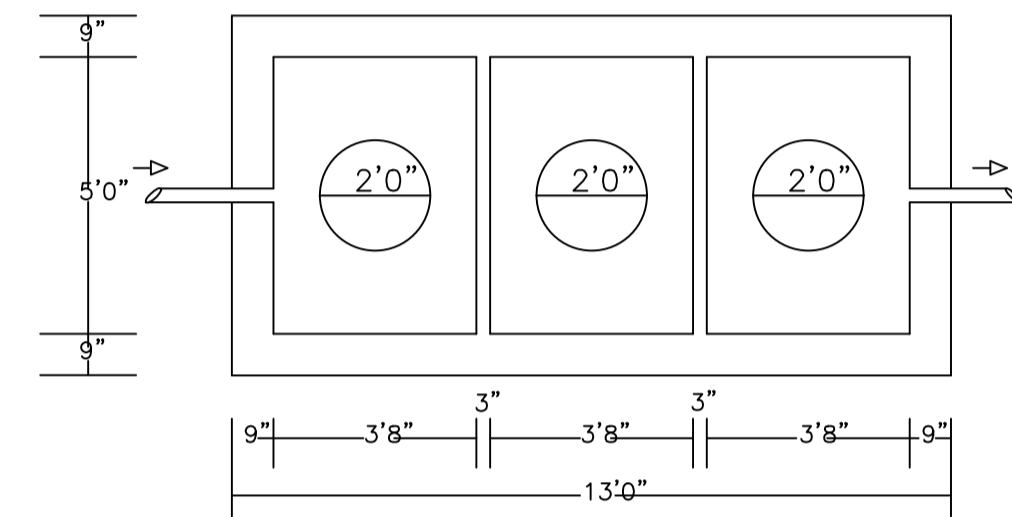

PLAN OF SEPTIC TANK
SCALE:- 1" = 4' - 0"

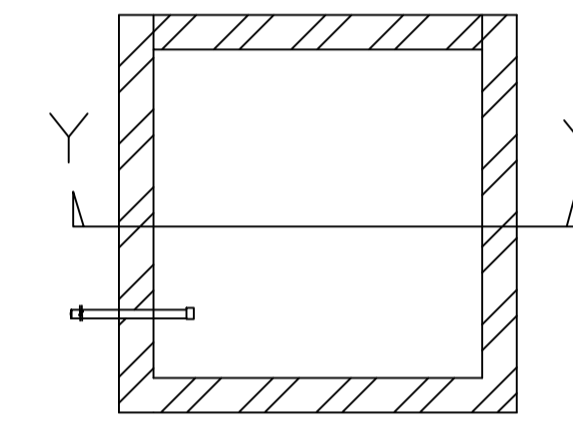

PLAN OF RECHARGE WELL

WATER HARVESTING
Scale 1" = 4' 0"

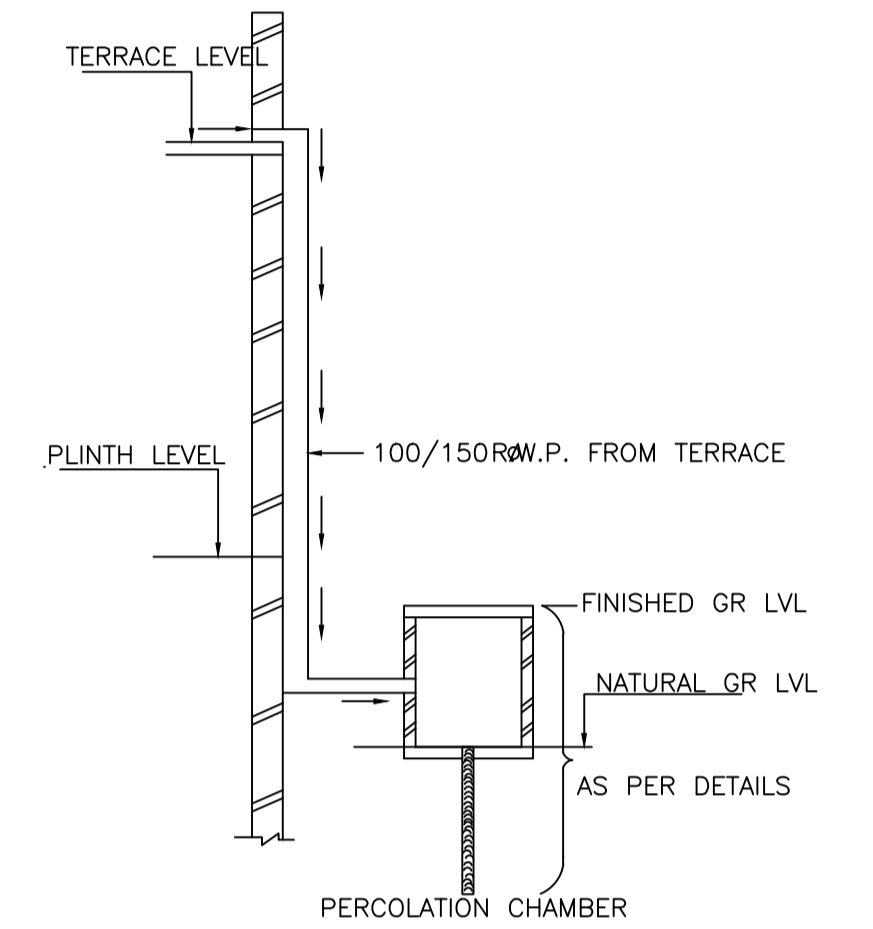

ROOF TOP RAIN WATER
COLLECTION SYSTEM

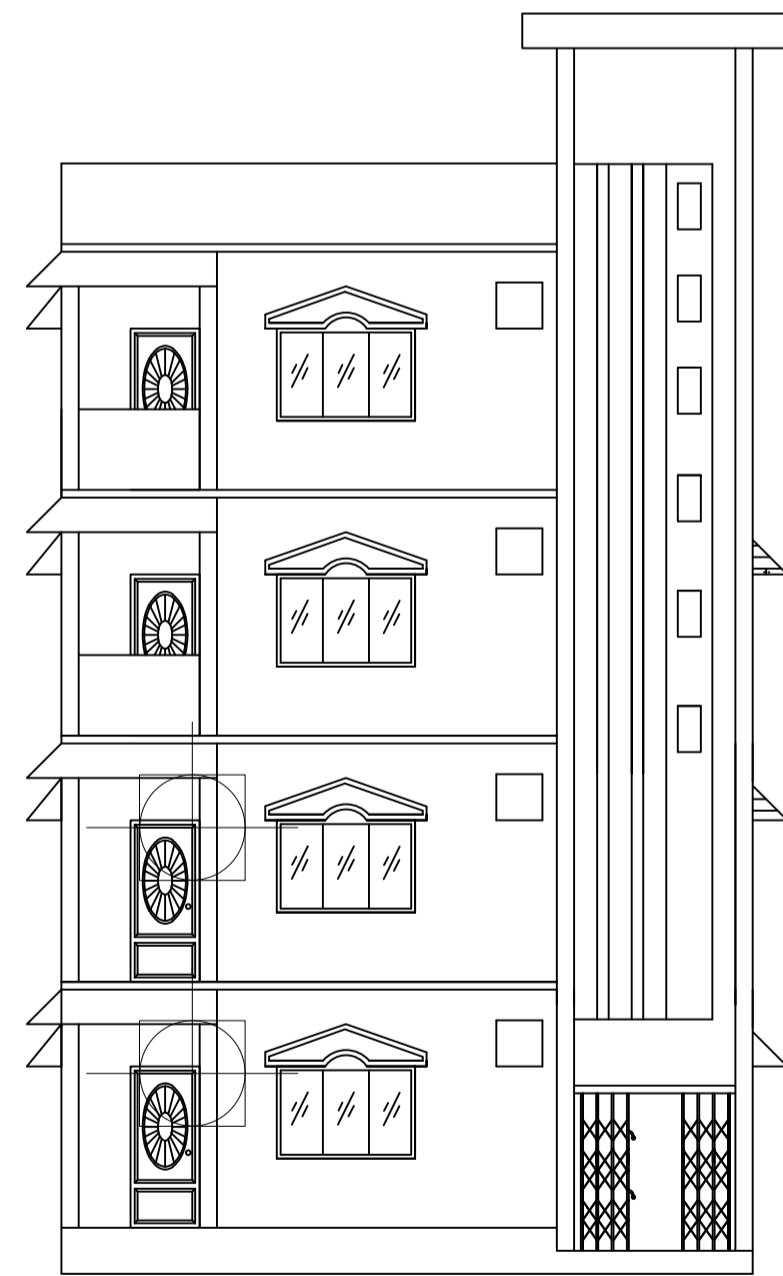

FRONT ELEVATION

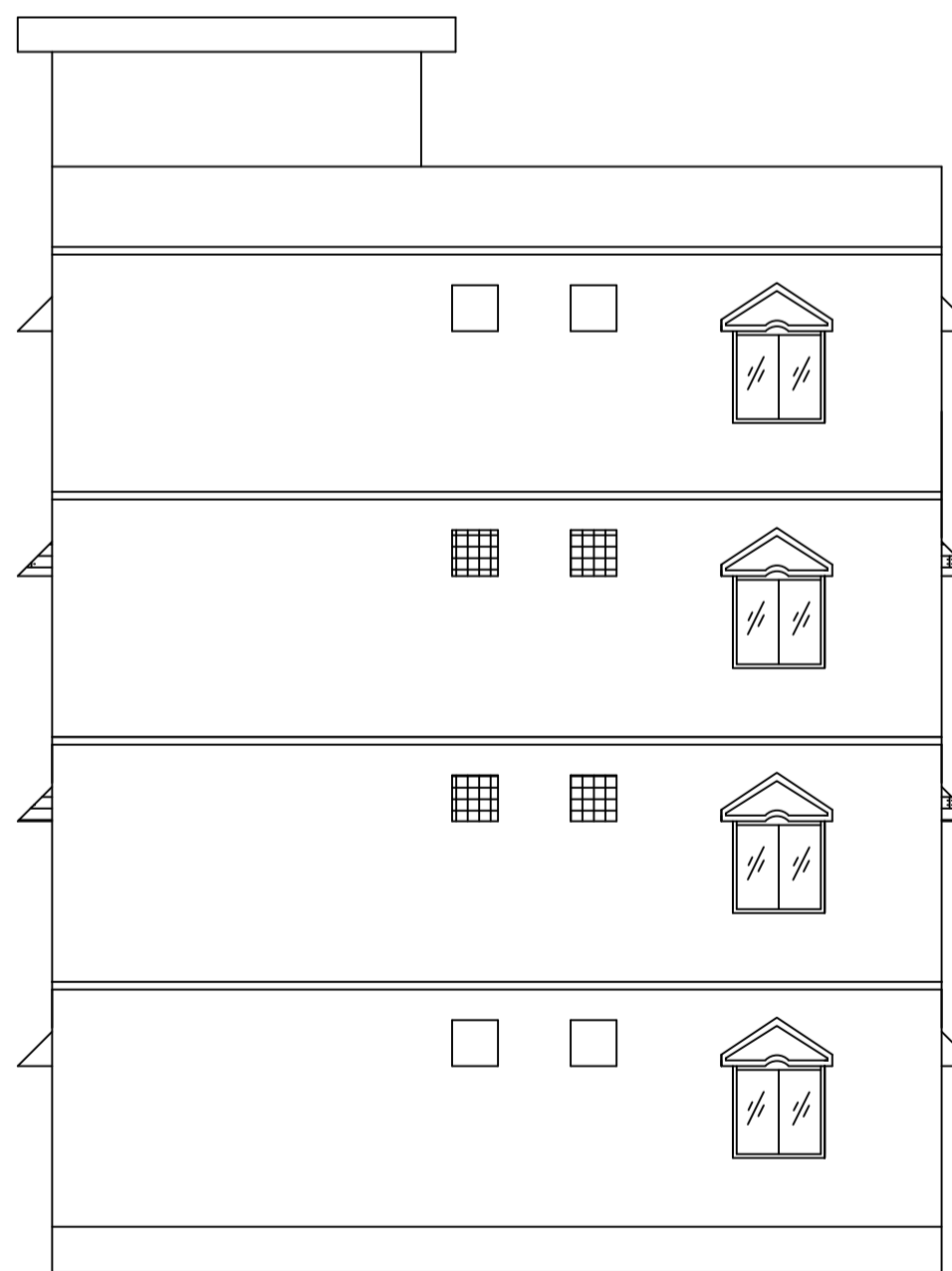

LEFT SIDE ELEVATION

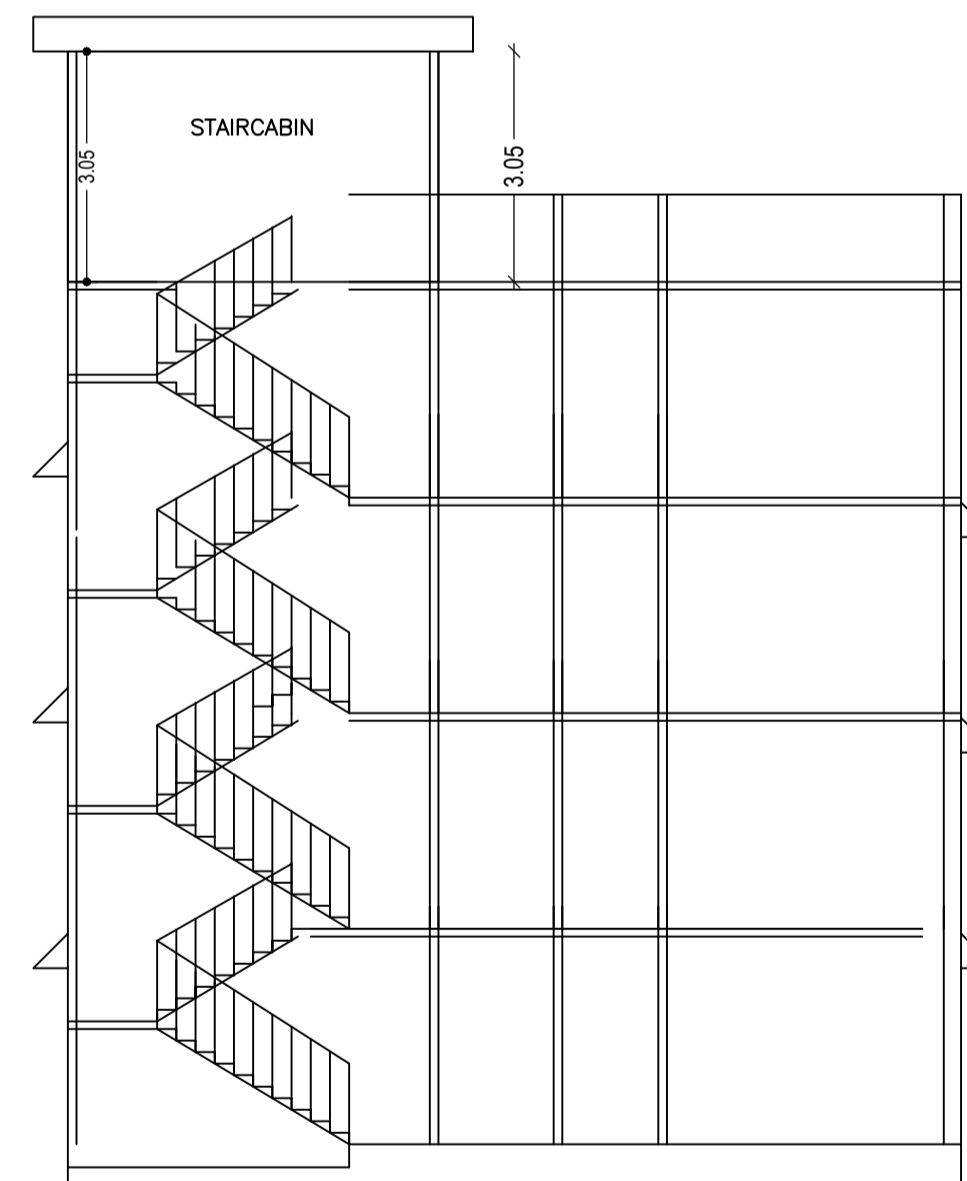

SECTION ON XX

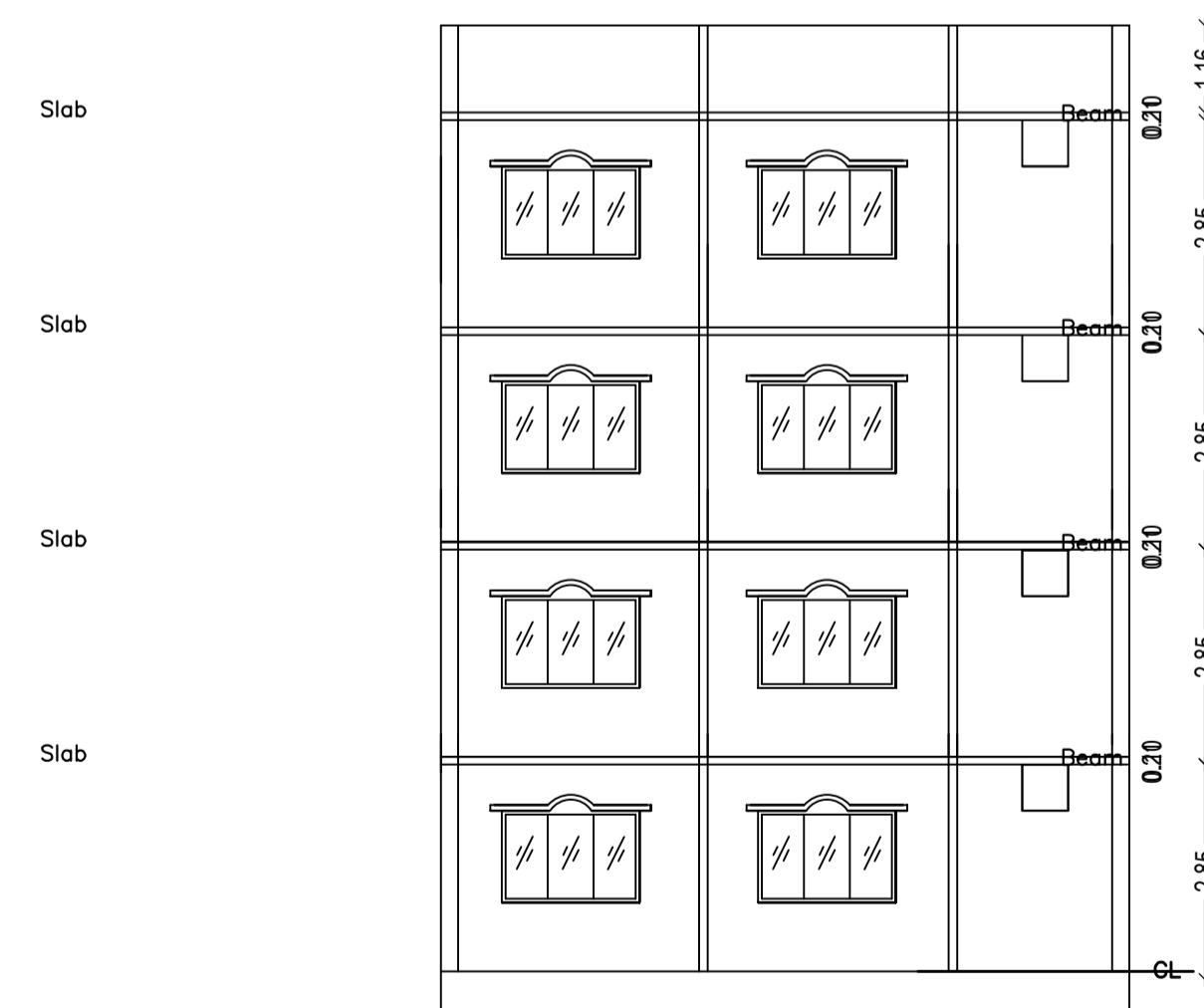

SECTION ON YY

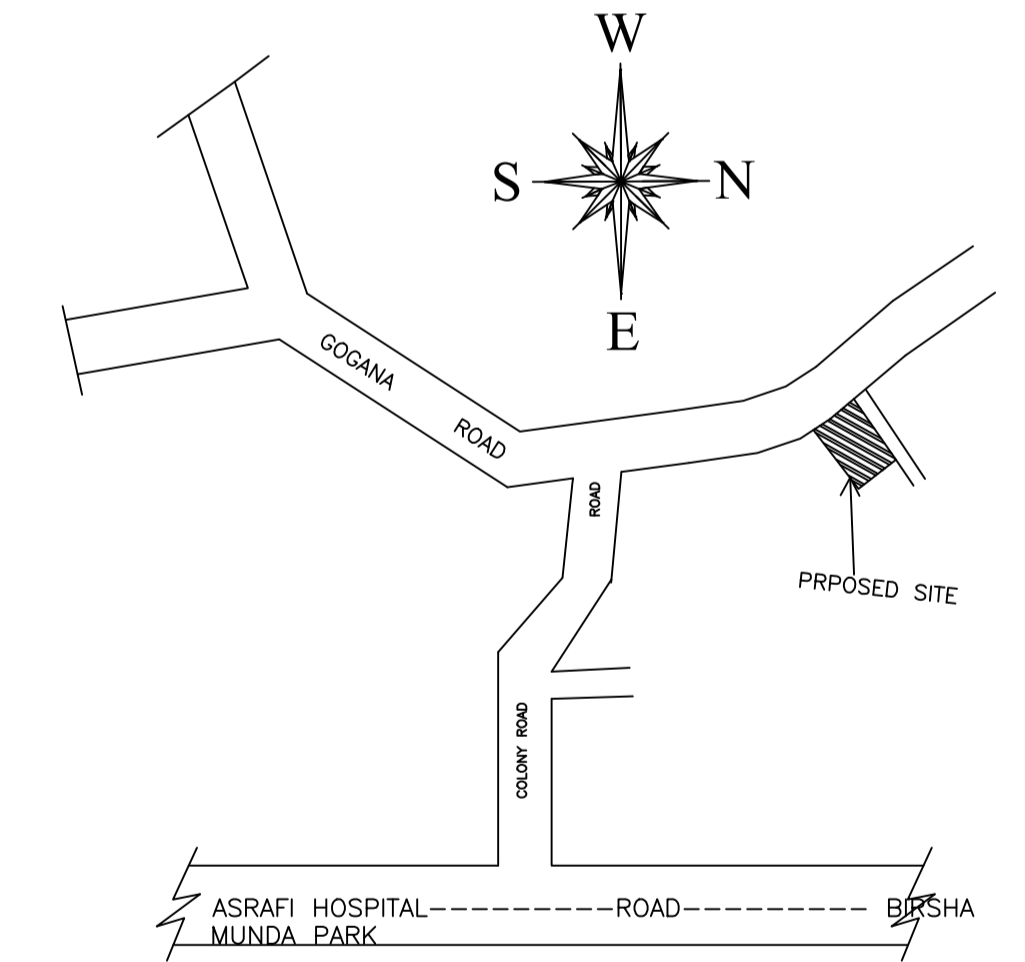

LOCATION PLAN
NOT TO SCALE



KEY PLAN
NOT TO SCALE

LTP NAME AND SIGNATURE	STRUCTURAL ENG'S NAME AND SIGNATURE	BUILDER NAME AND SIGNATURE	DIGITAL SIGNATURE
RAJEEV RANJAN SINGH MADA/ENG/0004/2019			