

**SITE PLAN**  
SCALE - 1" = 16'-0"

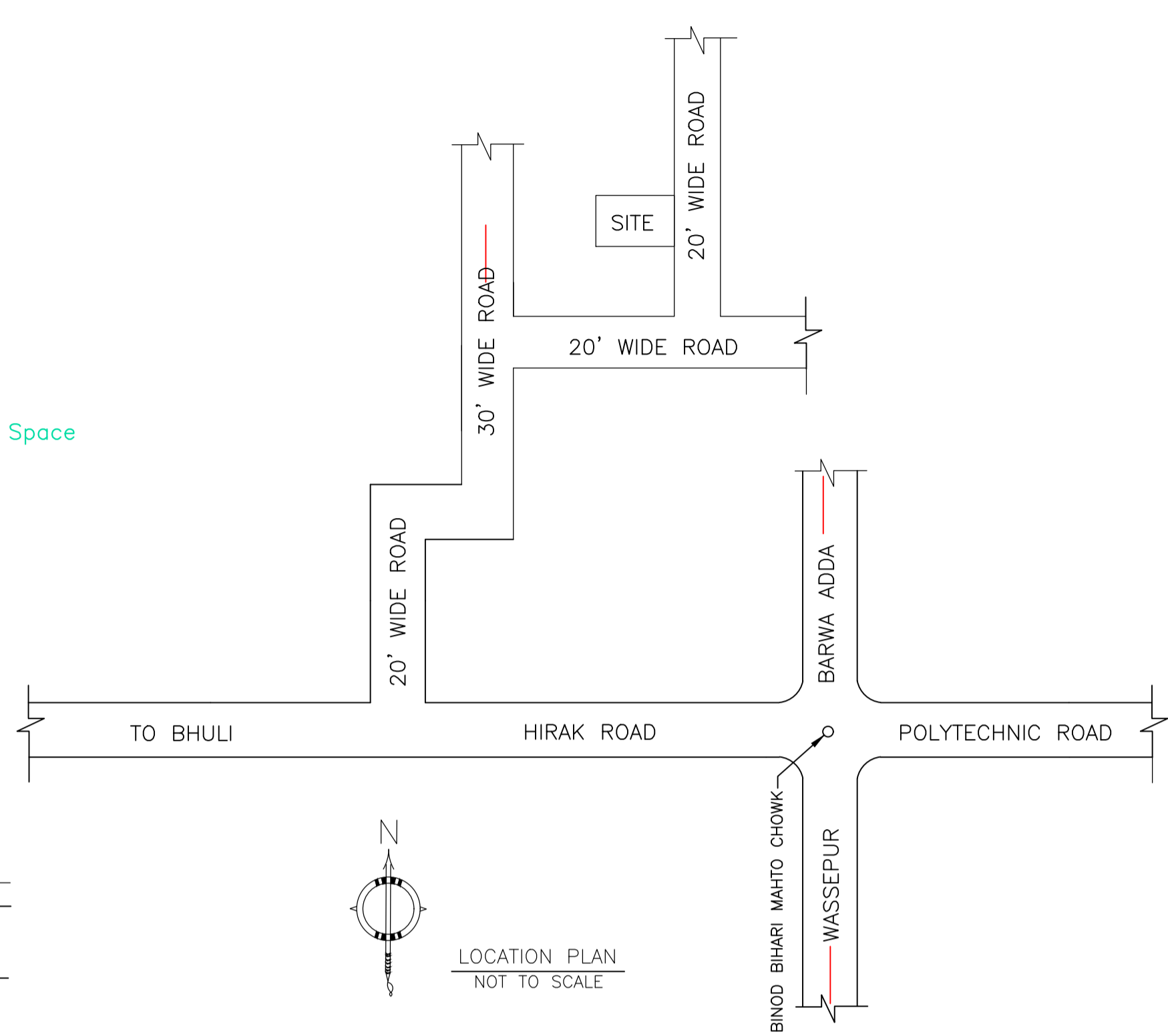

**LOCATION PLAN**  
NOT TO SCALE

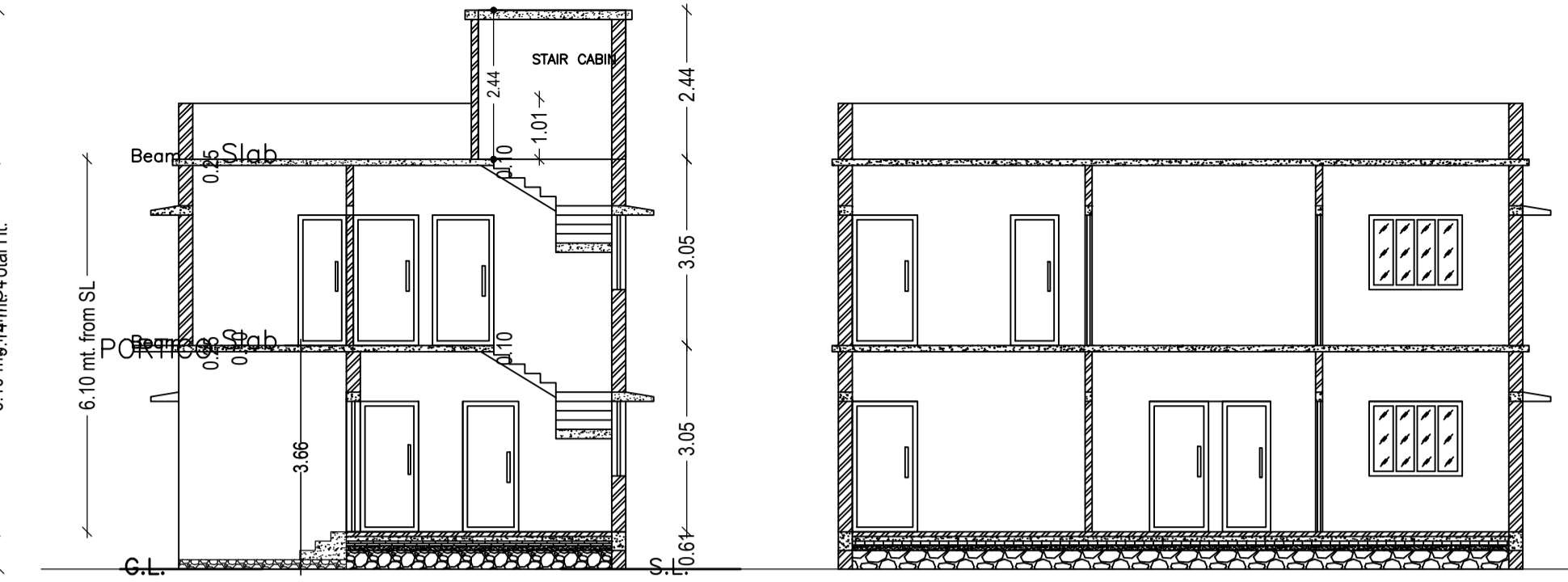

**SECTION - XX'**  
SCALE - 1" = 8'-0"

**SECTION - YY'**  
SCALE - 1" = 8'-0"

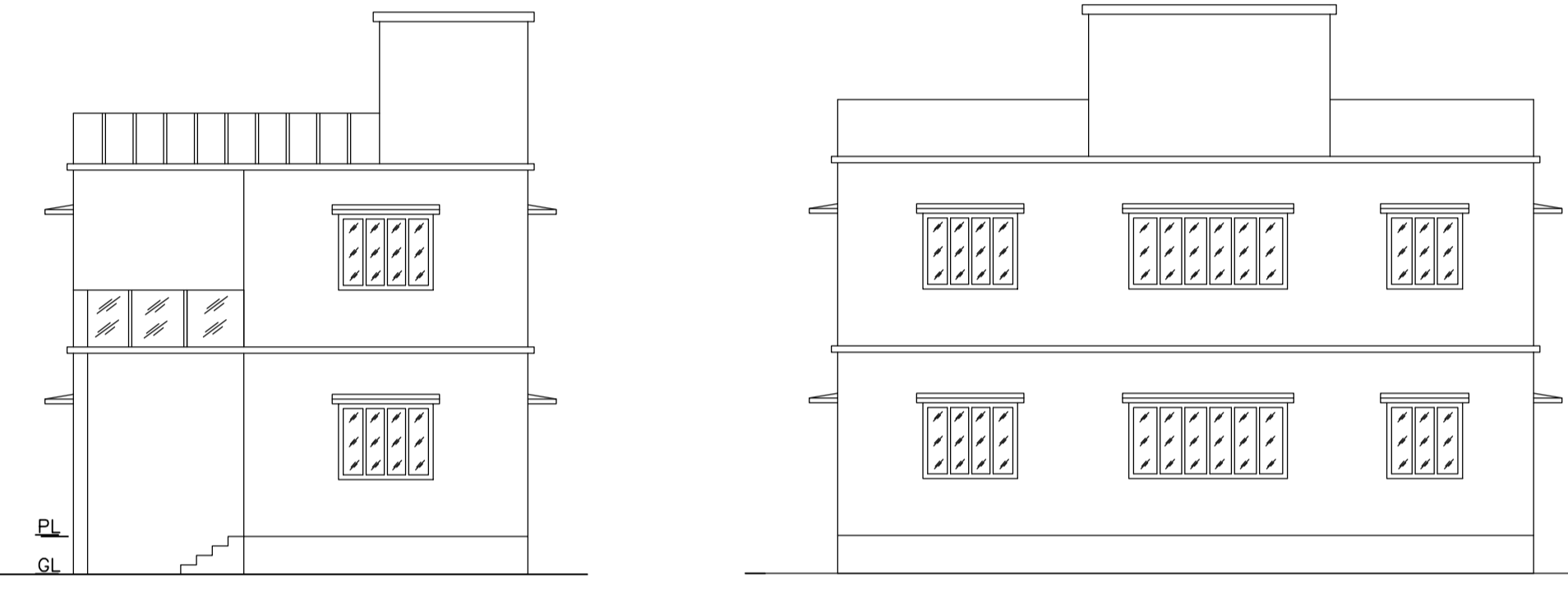

**FRONT ELEVATION**  
SCALE - 1" = 8'-0"

**RIGHT SIDE ELEVATION**  
SCALE - 1" = 8'-0"

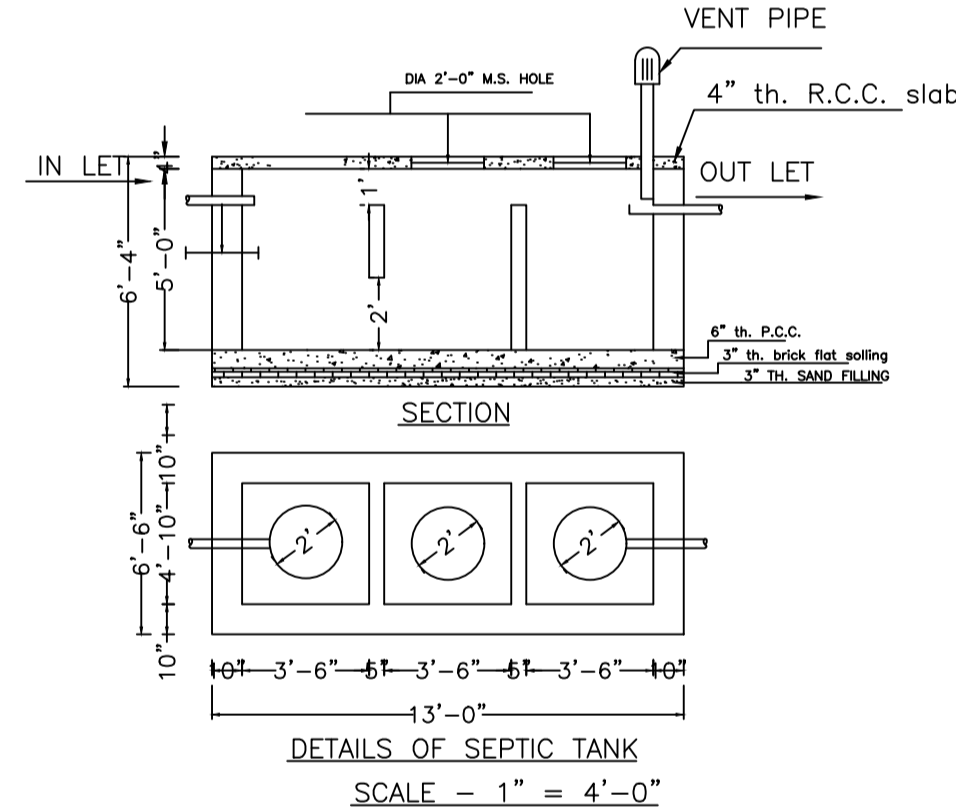
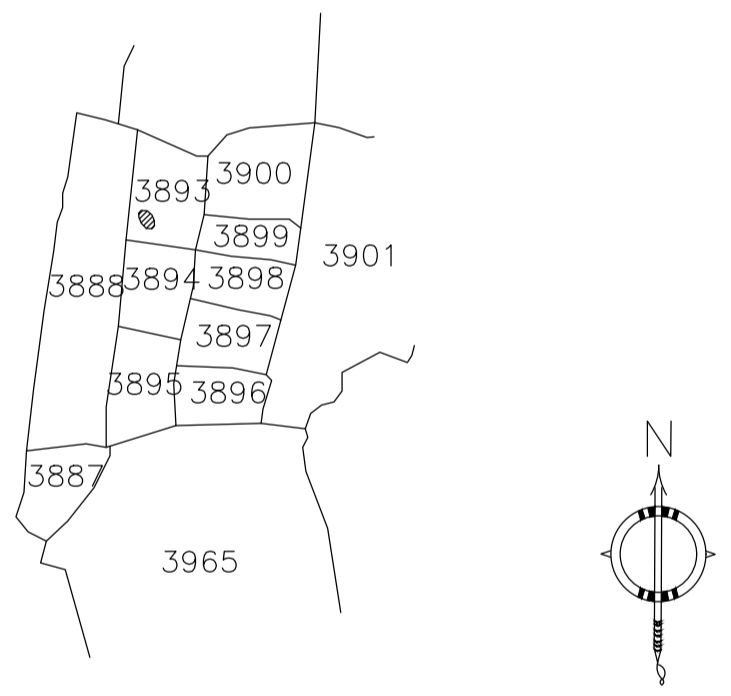

**DETAILS OF SEPTIC TANK**  
SCALE - 1" = 4'-0"

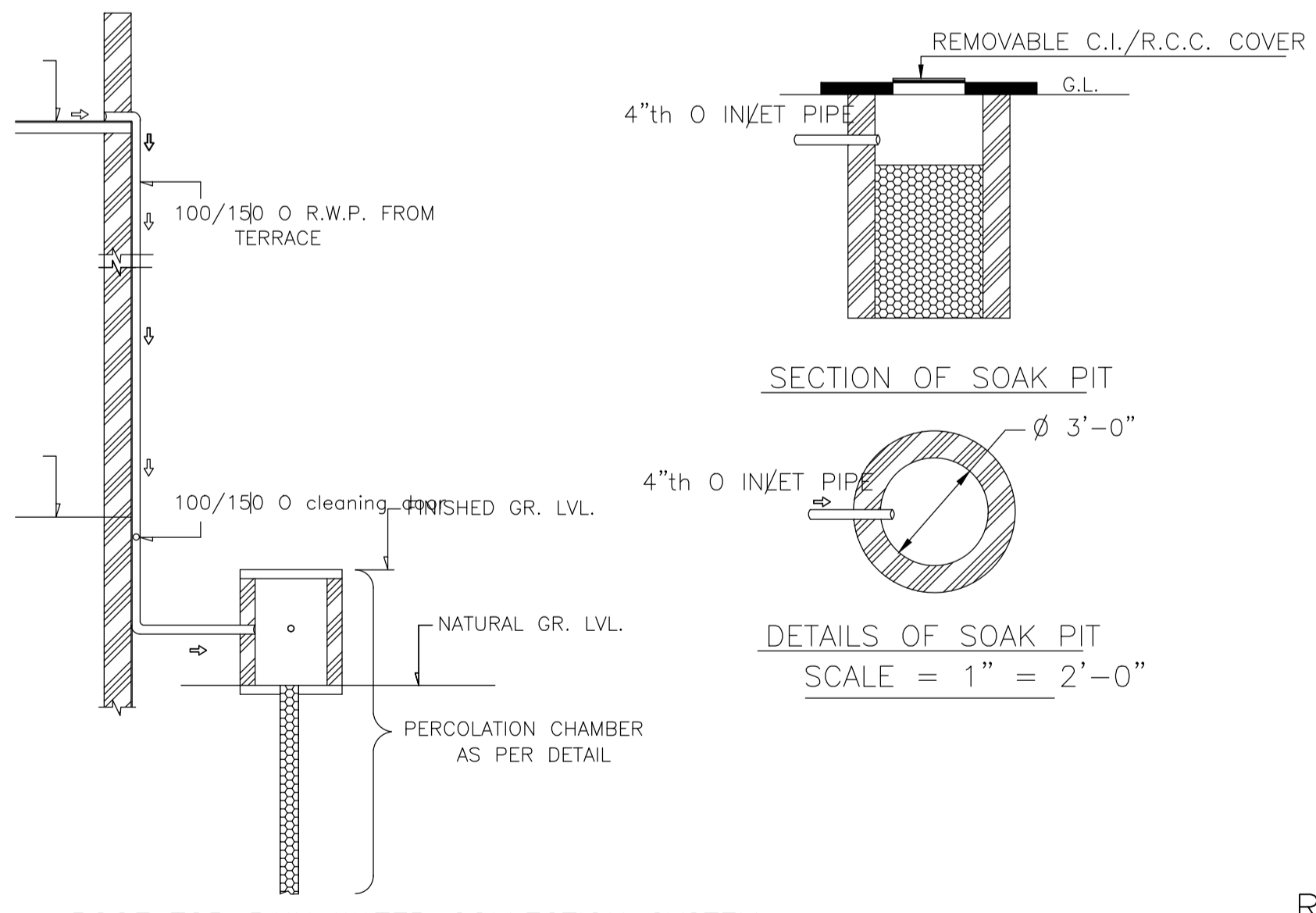

**ROOF TOP RAIN WATER COLLECTION SYSTEM**  
SCALE = 1" = 4'-0"

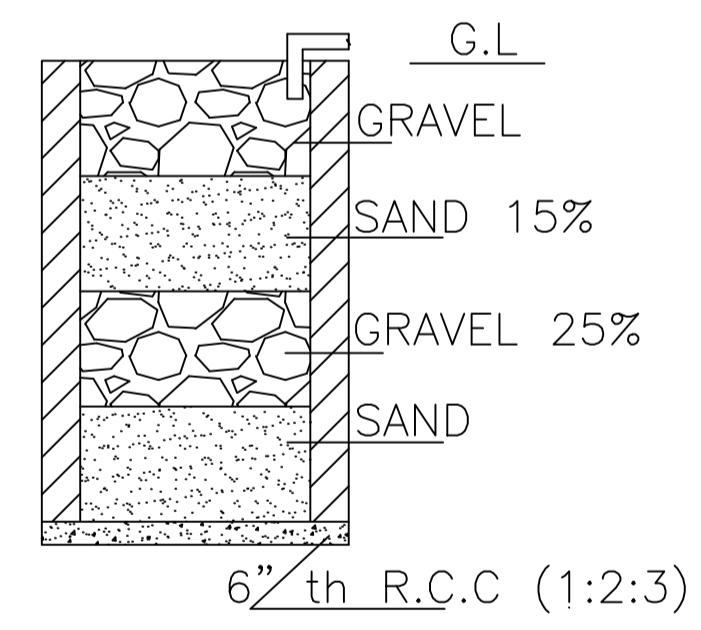

**SECTION ON A - B**

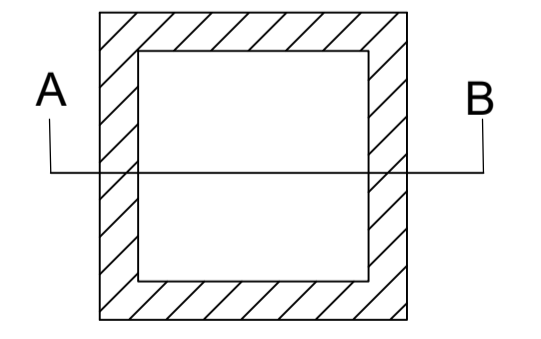

**DETAILS DRAWING OF RAIN WATER HARVESTING**  
SCALE:- 1"=2'-0"

**SCHEDULE OF DOOR:**

BUILDING NAME	NAME	LENGTH	HEIGHT	NOS
A (PARVATI)	D	0.76	2.10	02
A (PARVATI)	D	0.79	2.10	01
A (PARVATI)	D	0.91	2.10	01
A (PARVATI)	D	0.93	2.10	01
A (PARVATI)	D	0.97	2.10	01
A (PARVATI)	D	1.00	2.10	01
A (PARVATI)	D	1.07	2.10	04
A (PARVATI)	D	1.52	2.10	01

**SCHEDULE OF WINDOW/VENTILATION:**

BUILDING NAME	NAME	LENGTH	HEIGHT	NOS
A (PARVATI)	W	0.84	1.20	03
A (PARVATI)	W	1.22	1.20	01
A (PARVATI)	W	1.52	1.20	10
A (PARVATI)	W	2.55	1.20	02

**UnitBUA Table for Building :A (PARVATI)**

FLOOR	Name	UnitBUA Type	UnitBUA Area	Carpel Area	No. of Rooms	No. of Tenement
GROUND FLOOR PLAN	SPLIT 1	FLAT	147.26	146.60	5	1
FIRST FLOOR PLAN	SPLIT 1	FLAT	0.00	0.00	7	0
Total:	-	-	147.26	146.60	12	1

**FAR & Tenement Details (Table 4c-1)**

Building	No. of Same Bldg	Total Built Up Area (Sq.mt.)	Deductions (Area in Sq.mt.)	Proposed FAR Area (Sq.mt.)	Total FAR Area (Sq.mt.)	Total Consumed Additional FAR Area (Sq.mt.)	Tnmt (No.)
A (PARVATI)	1	163.88	16.62	147.26	147.26	147.26	01
Grand Total:	1	163.88	16.62	147.26	147.26	147.26	01

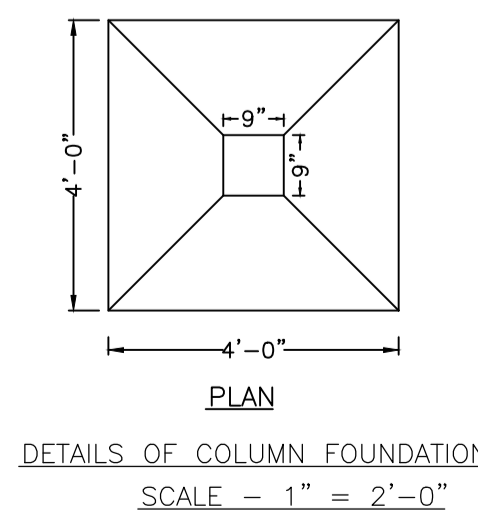

**DETAILS OF COLUMN FOUNDATION**  
SCALE - 1" = 2'-0"

**Proposal Basic Information**

Proposal File No.	MADA/BP/0375/2021
Owner Name	SMT. PARVATI DEVI
Khata No	OLD KHATA NO-79,NEW KHATA NO-156
Plot No	OLD PLOT NO. 2540, NEW PLOT NO. 3893
Village Name	Bara Pichri
Use	Residential
SubUse	Bungalow/ Dwelling / Non Apartment

**AREA STATEMENT MINERAL AREA DEVELOPMENT AUTHORITY**

Version No.	1.0.62
Version Date	16/10/2020
Region	JHARKHAND URBAN LOCAL BODIES
District	DHANBAD
Authority	MINERAL AREA DEVELOPMENT AUTHORITY
Inward No.	MADA/BP/0375/2021
Application Type	General Proposal
Project Type	Building Permission
Nature of Development	New
Location of Development Area	Old Area
Area	West: Plot No. - SAME PLOT
Plot Use	Residential
Plot SubUse	Bungalow/ Dwelling / Non Apartment
PlotNearby/ReligiousStructure	NA
Plot/SubPlot No.	OLD PLOT NO. 2540, NEW PLOT NO. 3893
North: Plot No.	- SAME PLOT
South: Plot No.	- SAME PLOT
East: Road Width	- 6.10
West: Plot No.	- SAME PLOT

**AREA DETAILS:**

AREA OF PLOT (Minimum)	(A)	SQ.MT.
NET AREA OF PLOT(Gross Plot Area - Deduction from Gross Plot area)	(A-Deductions)	138.76
Deduction for Balance Plot Area(from Gross Plot Area)		
Common Plot		14.07
Total		14.07
BALANCE AREA OF PLOT(Net Plot Area - Recreational/Amenity space)	(A-Deductions)	124.69
PLOT AREA FOR COVERAGE(Net Plot Area)	(A-Deductions)	138.76
Plot Area for FAR (Net Plot Area + Road/Widening Area)	(A-Deductions)	138.76

**COVERAGE CHECK**

Permissible Coverage area ( 70.00 % )	97.13
Proposed Coverage Area ( 47.08 % )	65.32
Total Prop. Coverage Area ( 47.08 % )	65.32
Balance coverage area ( 22.93 % )	31.81

**FAR CHECK**

Perm. FAR Area ( 2.50 )	346.90
Total Perm. FAR area	346.90
Residential FAR	147.26
Proposed FAR Area	147.26
Total Proposed FAR Area	147.26
Consumed FAR (Factor)	1.06
Balance FAR Area	199.64

**BUILT UP AREA CHECK**

Total Proposed BuiltUp Area	163.88
-----------------------------	--------

**ARCHITECT (Regd)** RAM PRATAP SINGH  
**ENGINEER (Regd)**  
**SUPERVISOR (Regd)**  
**OWNER (Regd)** SMT. PARVATI DEVI

**DEVELOPMENT AUTHORITY** LOCAL BODY

**COLOR INDEX**

PLOT BOUNDARY	Black
ABUTTING ROAD	Green
PROPOSED CONSTRUCTION	Red
COMMON PLOT	Yellow
ROAD WIDENING AREA	Blue
EXISTING (To be retained)	Light Blue
EXISTING (To be demolished)	Dark Blue

**Buildingwise Floor FAR Details**

Floor Name	A (PARVATI)		Total	
	Proposed Built Up Area (Sq.mt.)	Proposed FAR Area (Sq.mt.)	Total Proposed Built Up Area (Sq.mt.)	Total FAR Area (Sq.mt.)
Ground Floor	81.94	65.32	81.94	65.32
First Floor	81.94	81.94	81.94	81.94
Terrace Floor	0.00	0.00	0.00	0.00
Total:	163.88	147.26	163.88	147.26

**Building USE/SUBUSE Details**

Building Name	Building Use	Building SubUse	Building Structure
A (PARVATI)	Residential	Bungalow/ Dwelling / Non Apartment	Non-Highrise

**Building :A (PARVATI)**

Floor Name	Total Built Up Area (Sq.mt.)	Deductions (Area in Sq.mt.)		Total FAR Area (Sq.mt.)	Total Consumed Additional FAR Area (Sq.mt.)	Tnmt (No.)
		Archi.Proj.	Resi.			
Ground Floor	81.94	16.62	65.32	65.32	65.32	01
First Floor	81.94	0.00	81.94	81.94	81.94	00
Terrace Floor	0.00	0.00	0.00	0.00	0.00	00
Total:	163.88	16.62	147.26	147.26	147.26	01
Total Number of Same Buildings	1					
Total:	163.88	16.62	147.26	147.26	147.26	01

LTP NAME AND SIGNATURE	STRUCTURAL ENG'S NAME AND SIGNATURE	BUILDER NAME AND SIGNATURE	DIGITAL SIGNATURE
RAM PRATAP SINGH MADA/ARC/0024/2019			

Proposal Basic Information	
Proposal File No.	MADA/BP/0375/2021
Owner Name	SMT. PARVATI DEVI
Khata No	OLD KHATA NO-79, NEW KHATA NO-156
Plot No	OLD PLOT NO. 2540, NEW PLOT NO. 3893
Village Name	Bara Pichri
Use	Residential
SubUse	Bungalow/ Dwelling / Non Apartment

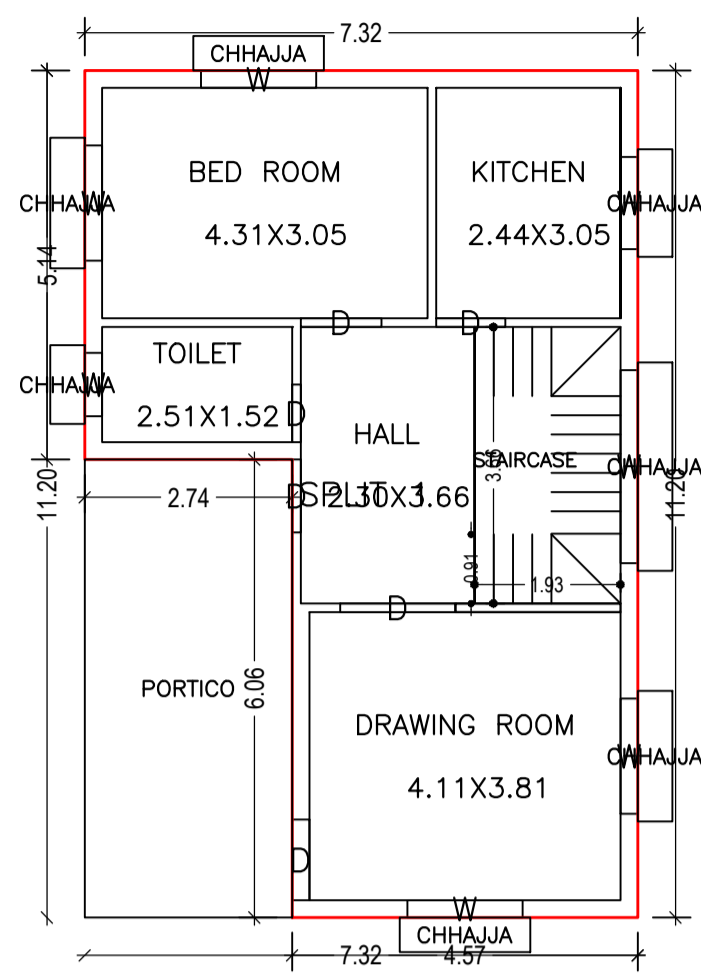

GROUND FLOOR PLAN  
(Proposed)  
(SCALE 1:100)

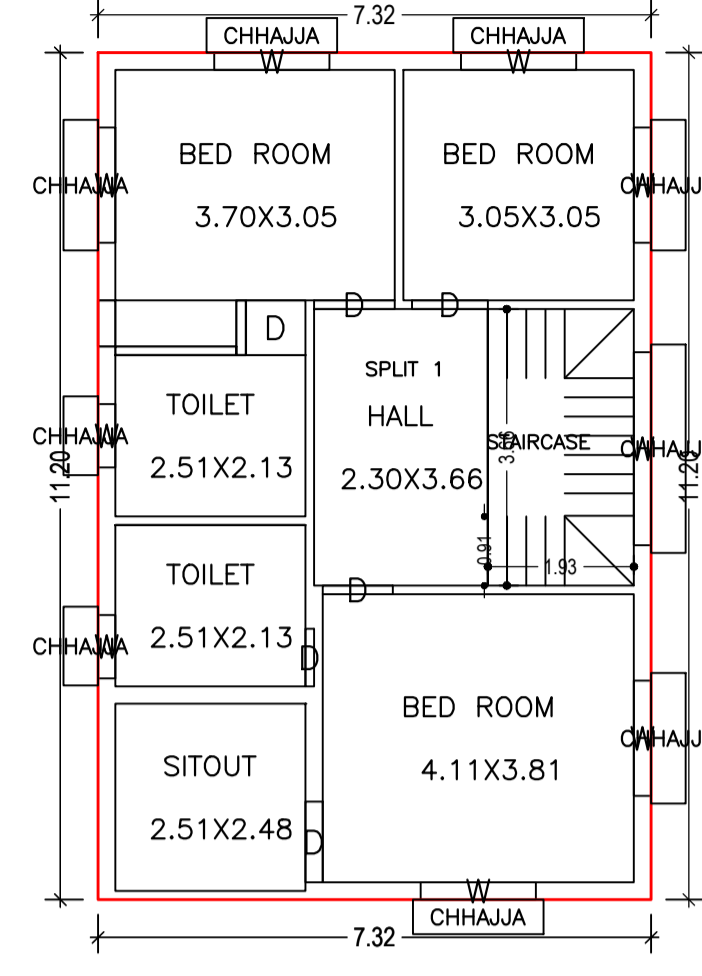

FIRST FLOOR PLAN  
(Proposed)  
(SCALE 1:100)

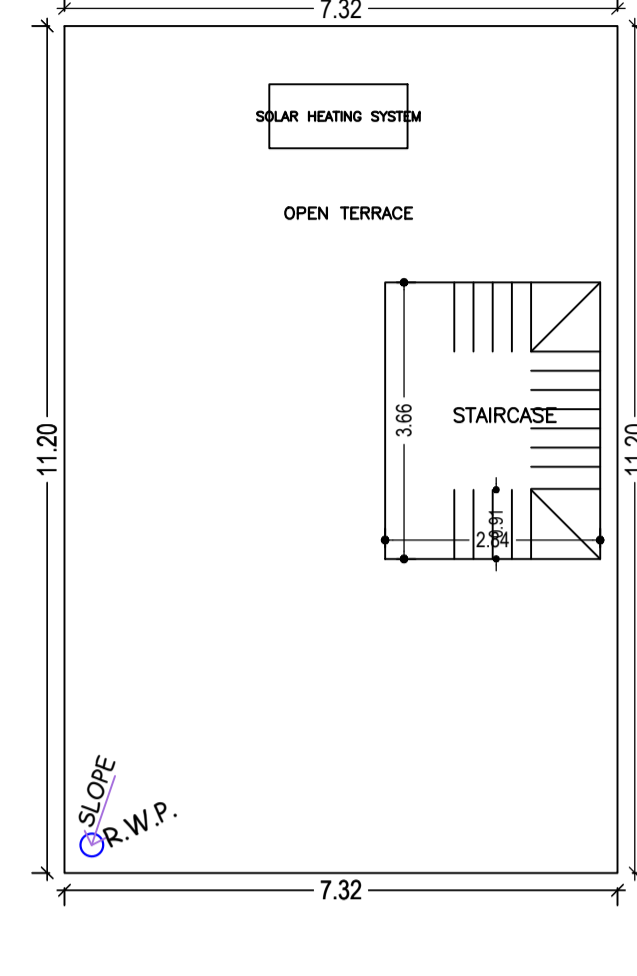

TERRACE FLOOR PLAN  
(SCALE 1:100)

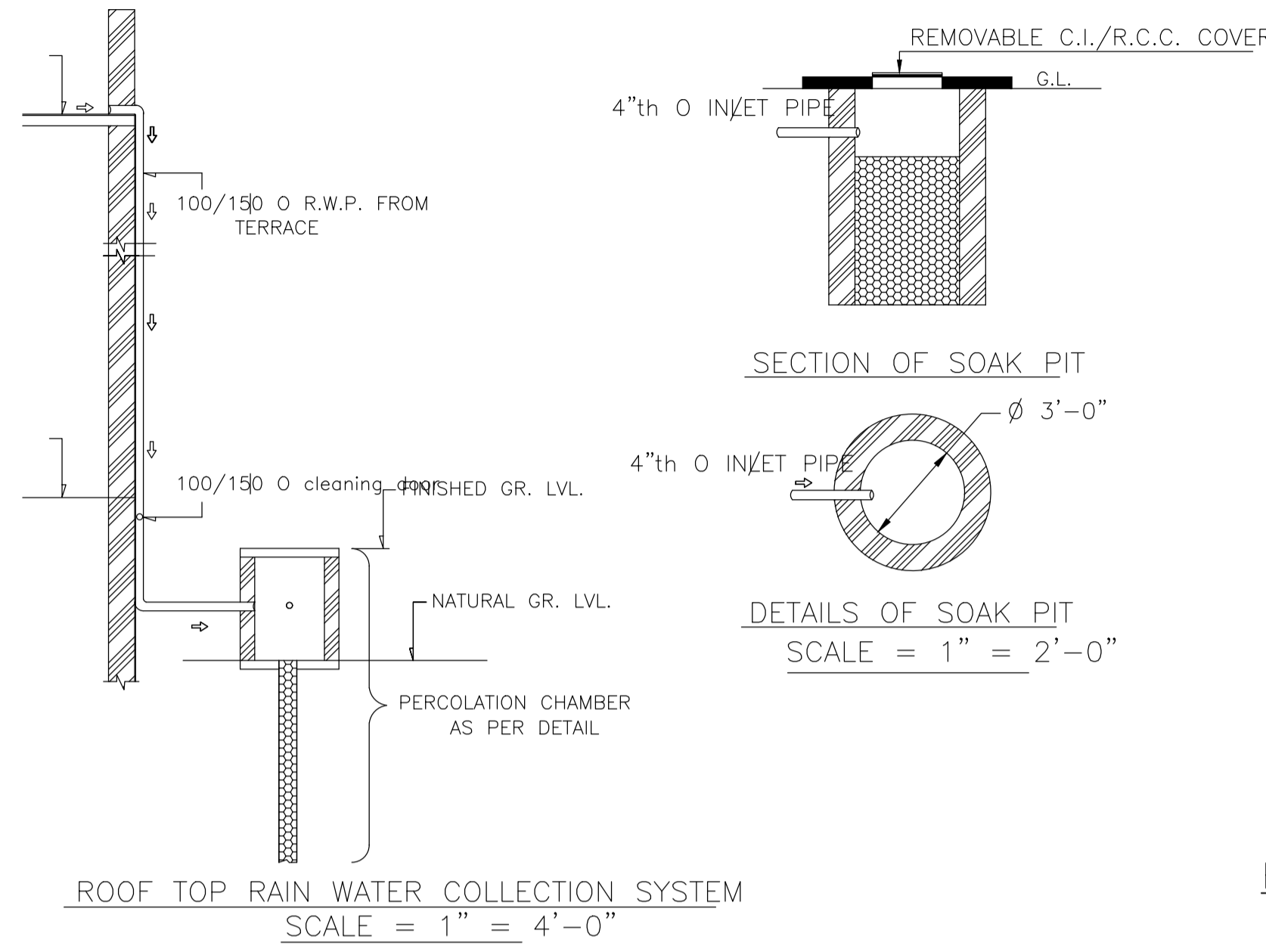

ROOF TOP RAIN WATER COLLECTION SYSTEM  
SCALE = 1" = 4'-0"

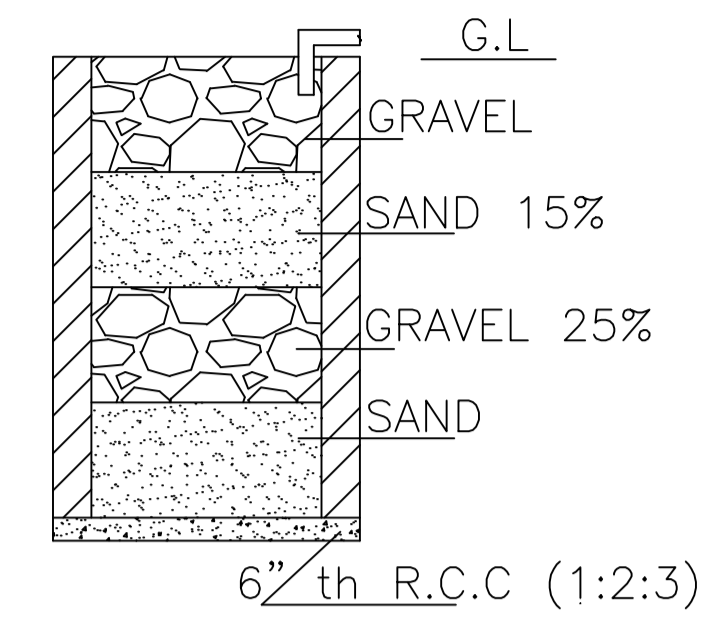

SECTION ON A - B

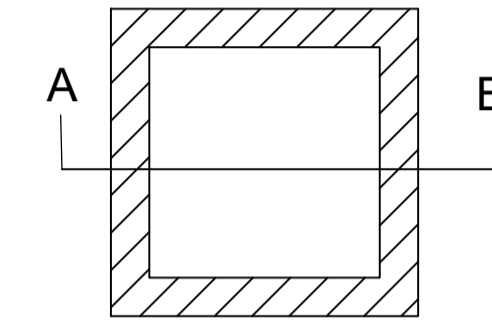

DETAILS DRAWING OF  
RAIN WATER HARVESTING  
SCALE:- 1"=2'-0"

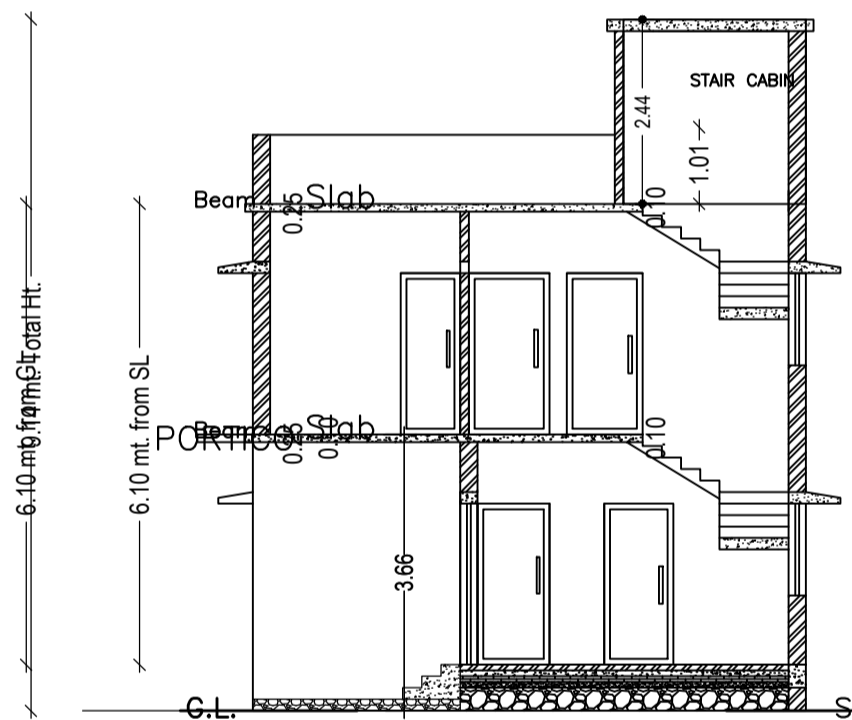

SECTION - XX'  
SCALE - 1" = 8'-0"

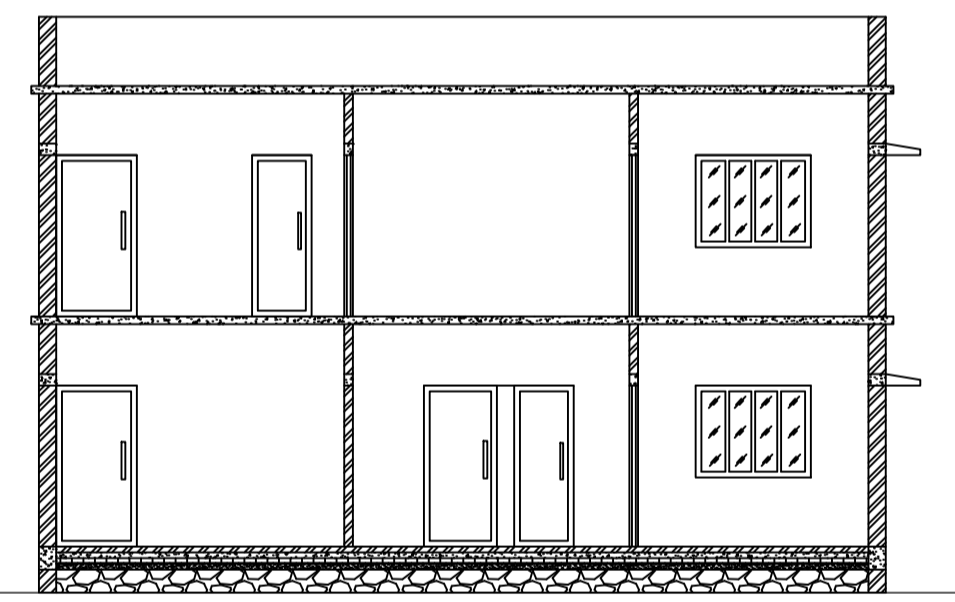

SECTION - YY'  
SCALE - 1" = 8'-0"

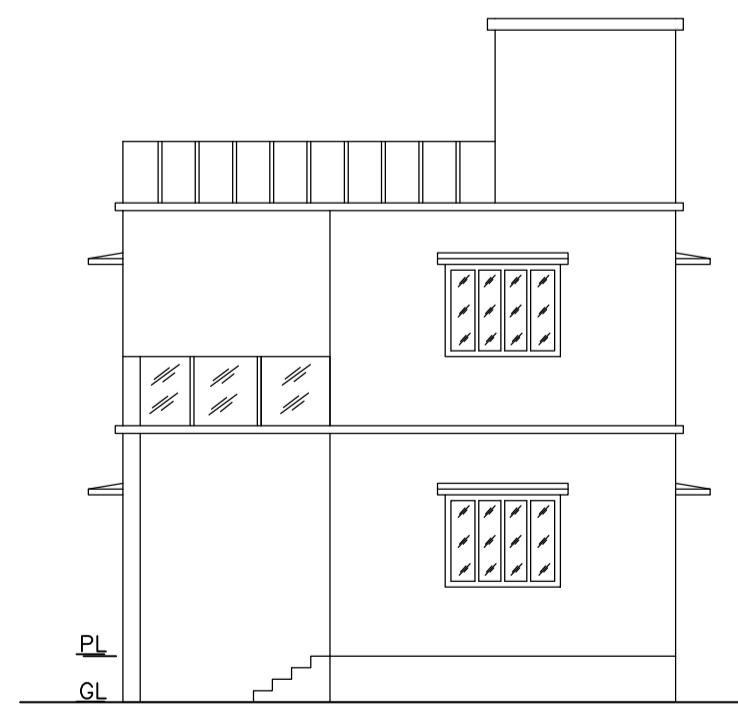

FRONT ELEVATION  
SCALE - 1" = 8'-0"

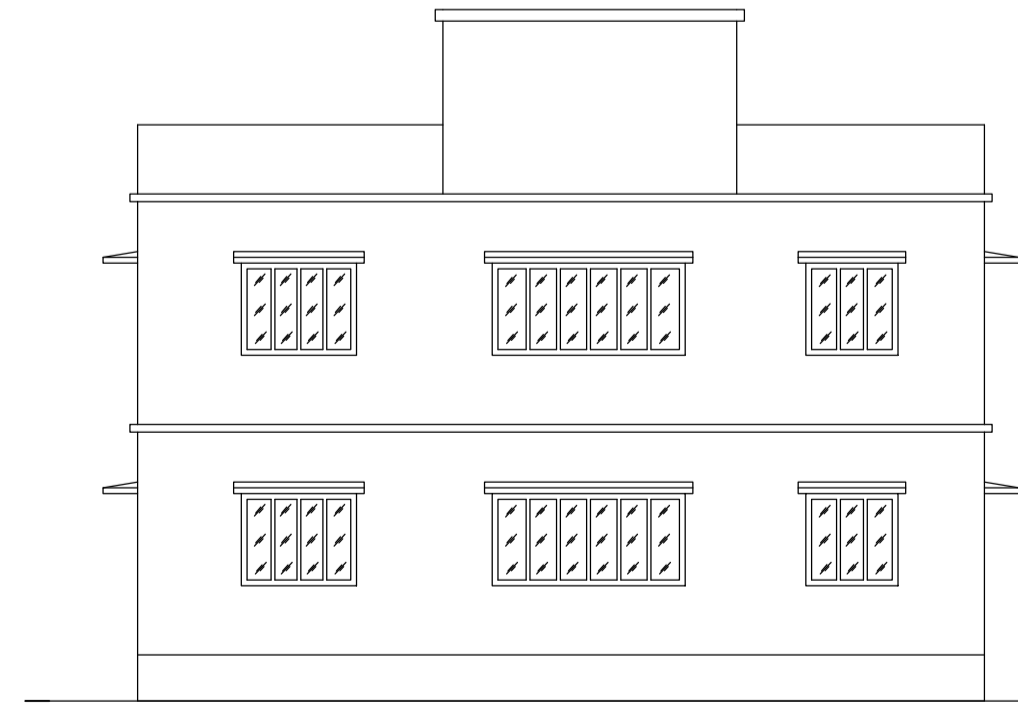

RIGHT SIDE ELEVATION  
SCALE - 1" = 8'-0"

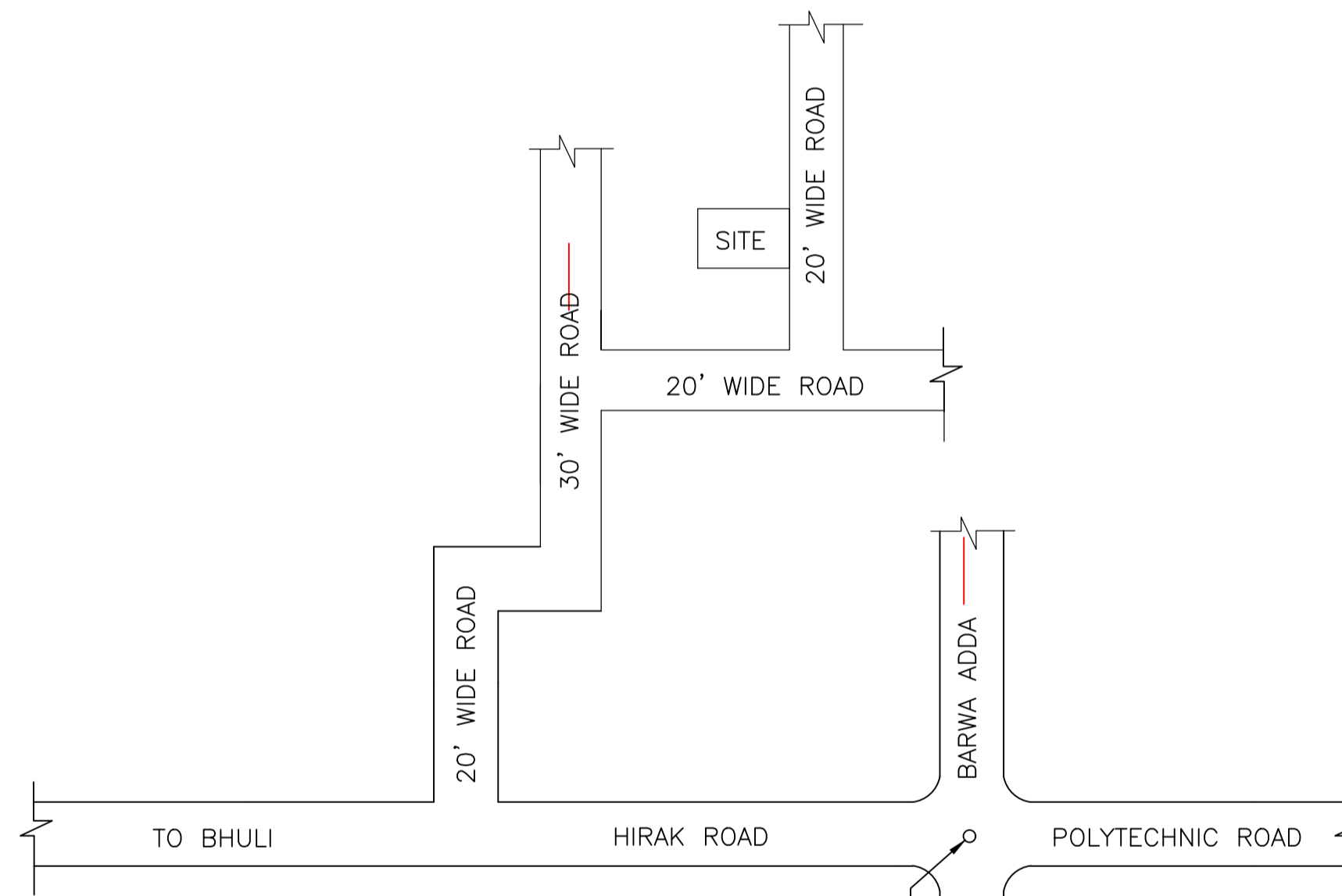

LOCATION PLAN  
NOT TO SCALE

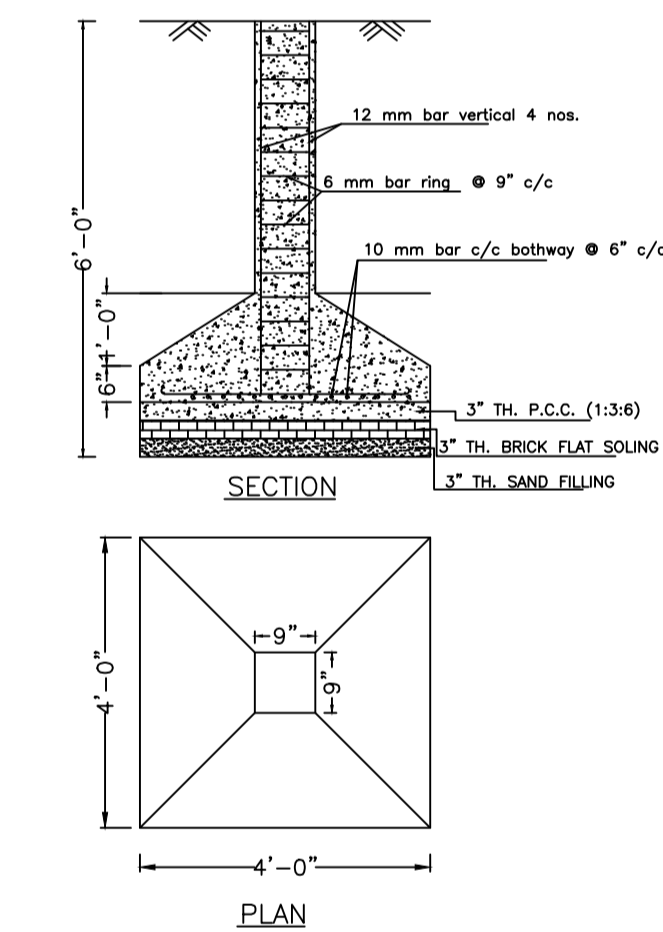
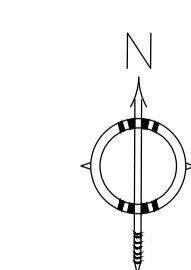
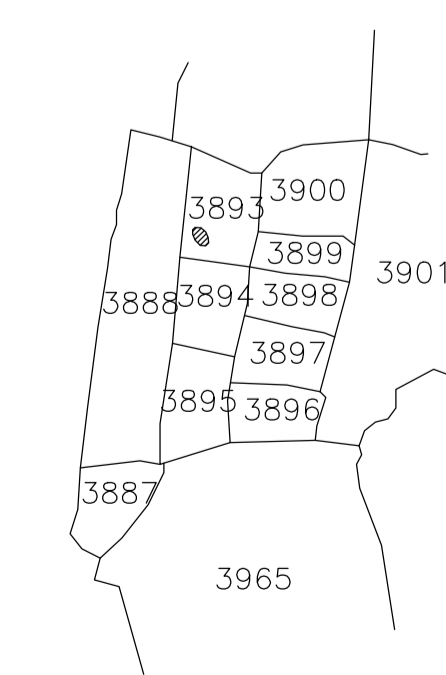

DETAILS OF COLUMN FOUNDATION  
SCALE - 1" = 2'-0"

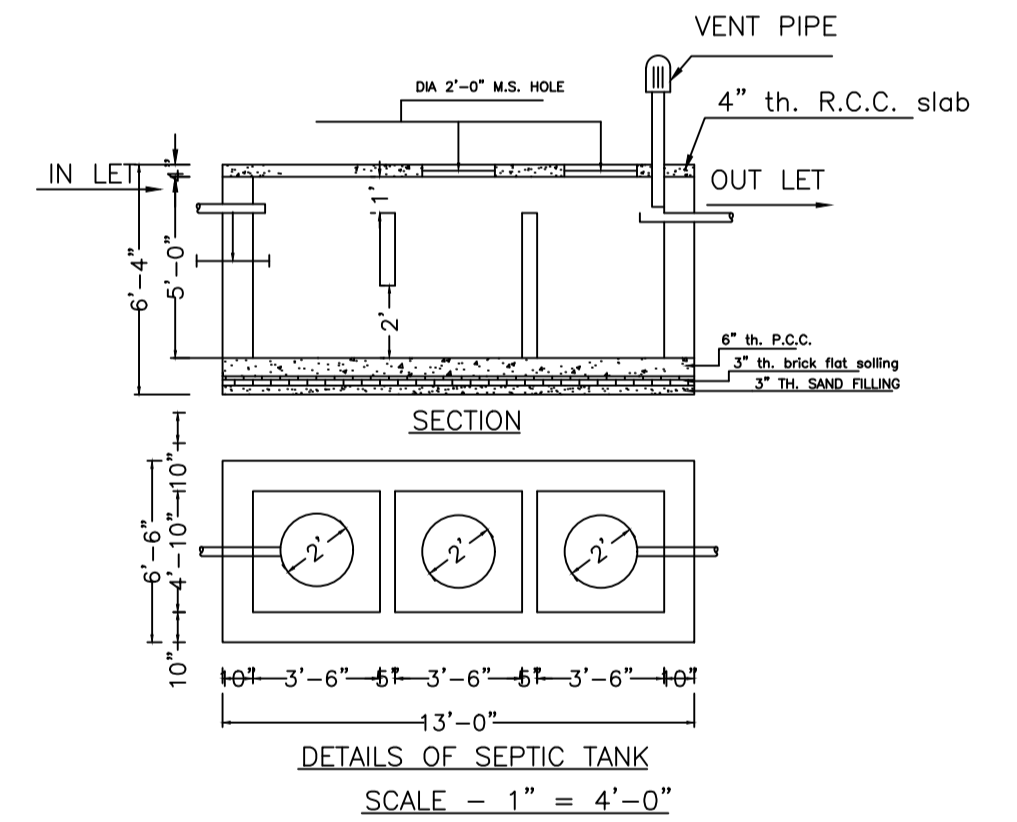

DETAILS OF SEPTIC TANK  
SCALE - 1" = 4'-0"

LTP NAME AND SIGNATURE	STRUCTURAL ENG'S NAME AND SIGNATURE	BUILDER NAME AND SIGNATURE	DIGITAL SIGNATURE
RAM PRATAP SINGH MADA/ARC/0024/2019			