

Proposal Basic Information

Proposal File No.	MADA/BP/0081/2021
Owner Name	SRI. SANTOSH KUMAR GOSWAMI
Khata No	07 (OLD) , New Khata No. - 20
Plot No	302 (OLD) , NEW PLOT NO. - 529
Village Name	Narayanpur
Use	Residential
SubUse	Bungalow/ Dwelling / Non Apartment

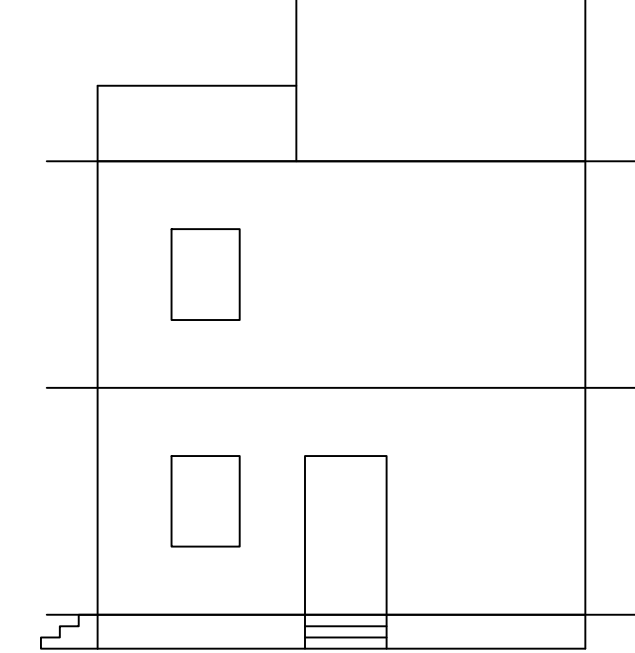
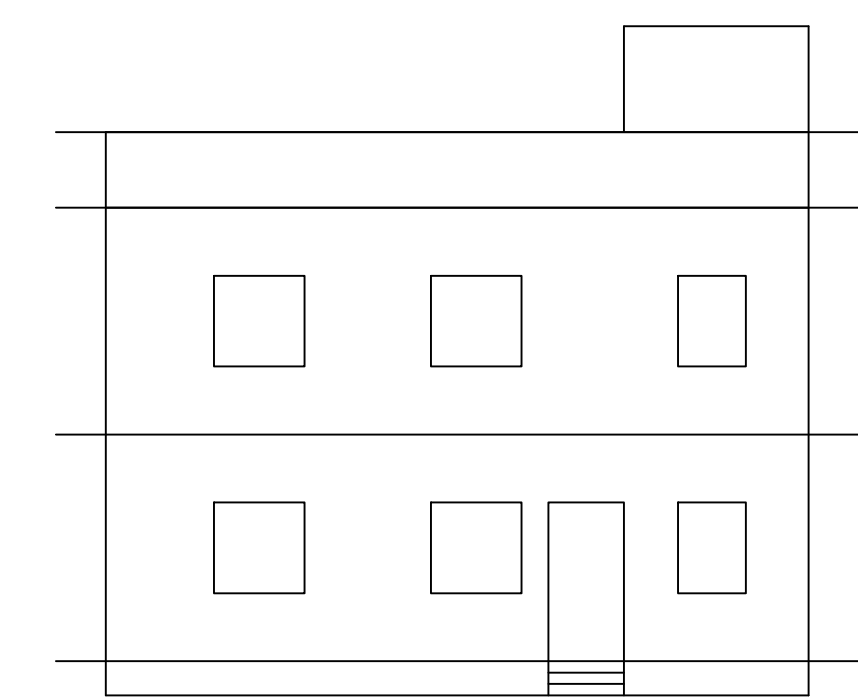
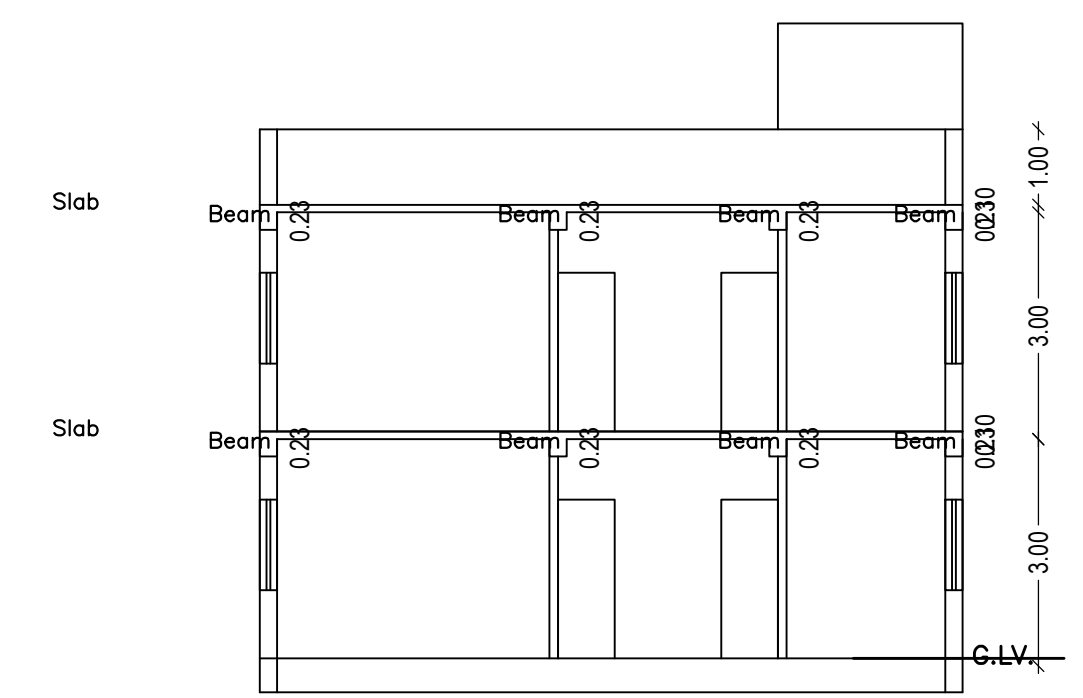
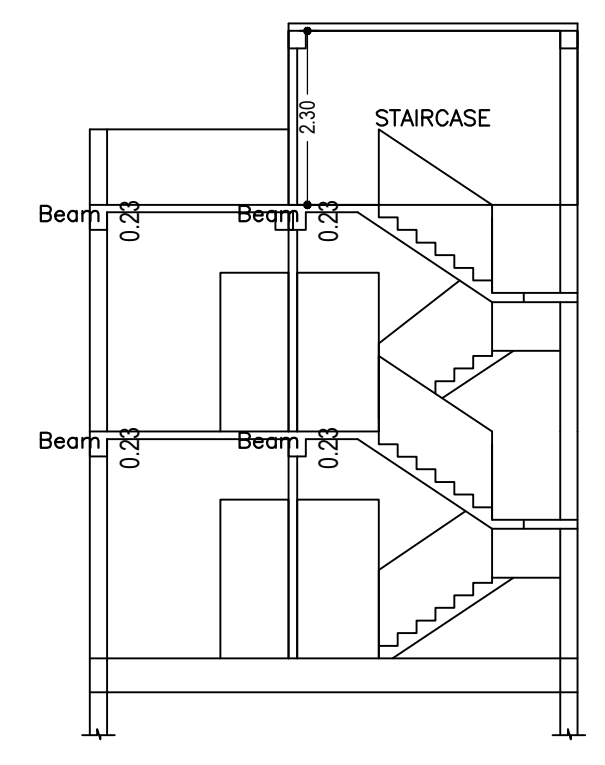
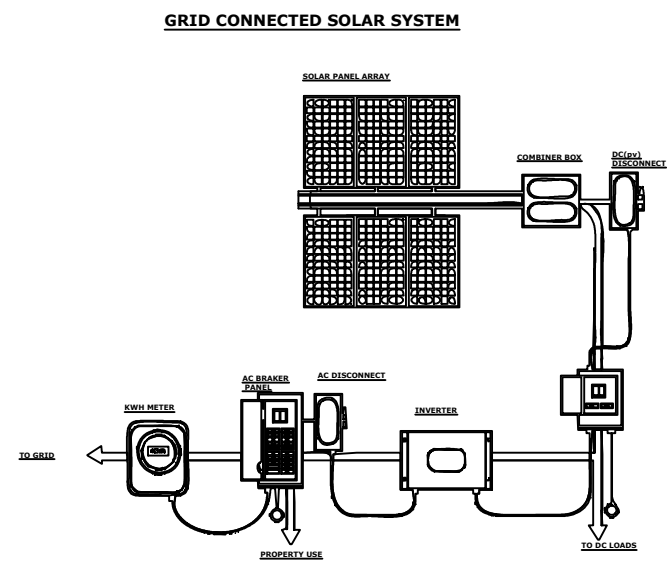
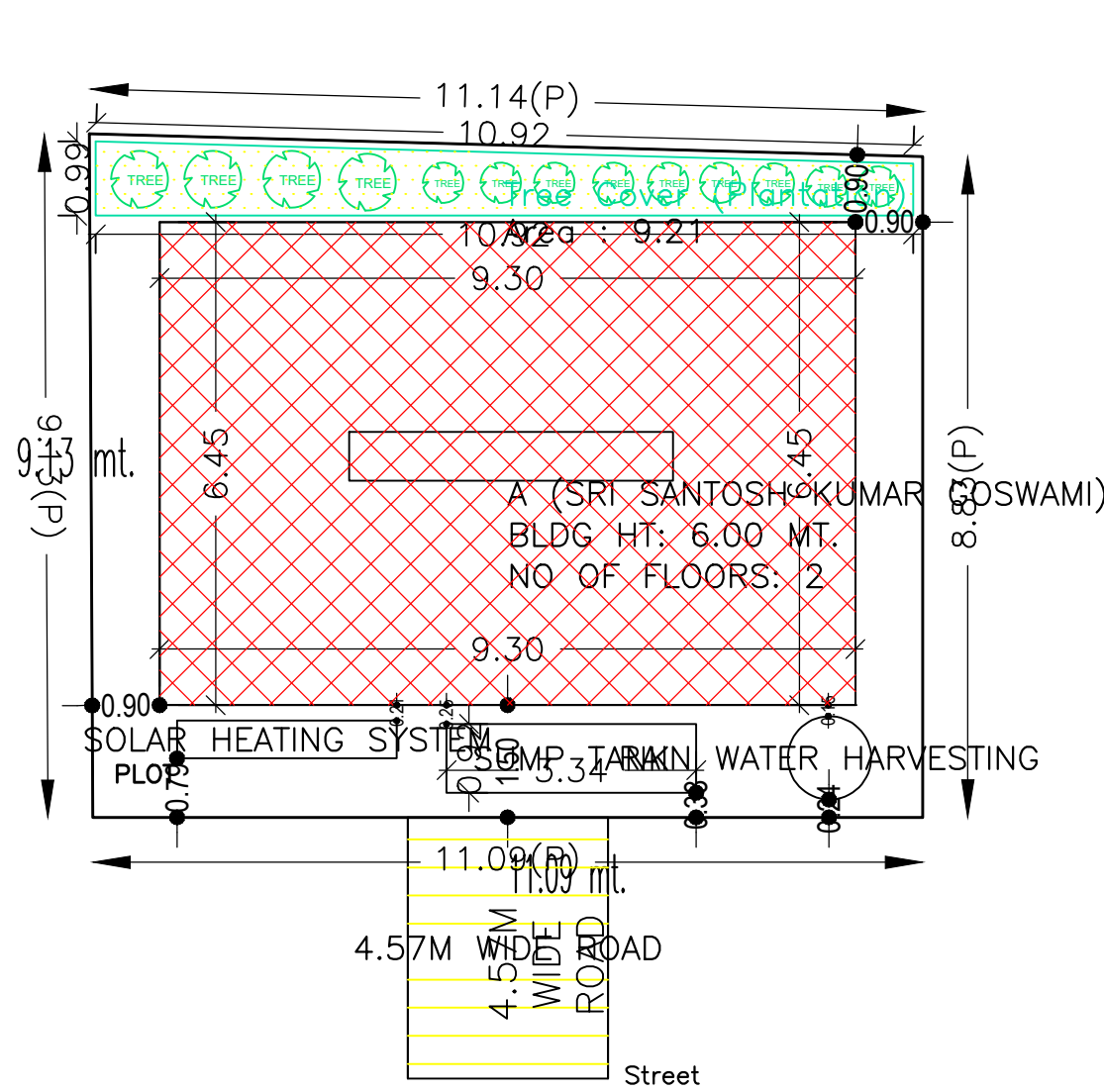

AREA STATEMENT MINERAL AREA DEVELOPMENT AUTHORITY	VERSION NO.: 1.0.60 VERSION DATE: 16/10/2020
PROJECT DETAIL:	
Region: JHARKHAND URBAN LOCAL BODIES	Plot Use: Residential
District: DHANBAD	Plot SubUse: Bungalow/ Dwelling / Non Apartment
Authority: MINERAL AREA DEVELOPMENT AUTHORITY	Plot/Nearby/ReligiousStructure: NA
Inward No: MADA/BP/0081/2021	Plot/SubPlot No: 302 (OLD) , NEW PLOT NO. - 529
Application Type: General Proposal	North: Plot No. - BISWAS BANERJI
Project Type: Building Permission	South: Plot No. - RASTA & NIZ
Nature of Development: New	East: Plot No. - PURCHASER NIZ
Location of Development Area: Old Area	West: Plot No. - SANGITA DEVI
AREA DETAILS:	
AREA OF PLOT (Minimum)	(A) 99.81 SQ.MT.
NET AREA OF PLOT(Gross Plot Area - Deduction from Gross Plot area)	(A-Deductions) 99.81
Deduction for Balance Plot Area(from Gross Plot Area)	
Common Plot	9.21
Total	9.21
BALANCE AREA OF PLOT(Net Plot Area - Recreational/Amenity space)	(A-Deductions) 90.60
PLOT AREA FOR COVERAGE(Net Plot Area)	(A-Deductions) 99.81
Plot Area for FAR (Net Plot Area + RoadWidening Area)	(A-Deductions) 99.81
COVERAGE CHECK	
Permissible Coverage area (70.00 %)	69.87
Proposed Coverage Area (60.12 %)	60.01
Total Prop. Coverage Area (60.12 %)	60.01
Balance coverage area (9.88 %)	9.86
FAR CHECK	
Perm. FAR Area (1.50)	149.71
Total Perm. FAR area	149.71
Residential FAR	120.02
Proposed FAR Area	120.02
Total Proposed FAR Area	120.02
Consumed FAR (Factor)	1.20
Balance FAR Area	29.69
BUILT UP AREA CHECK	
Total Proposed BuiltUp Area	120.02
ARCHITECT (Regd)	Piyush Kanti Singh
ENGINEER (Regd)	
SUPERVISOR (Regd)	
OWNER (Regd)	SRI SANTOSH KUMAR GOSWAMI
DEVELOPMENT AUTHORITY LOCAL BODY	

SITE PLAN

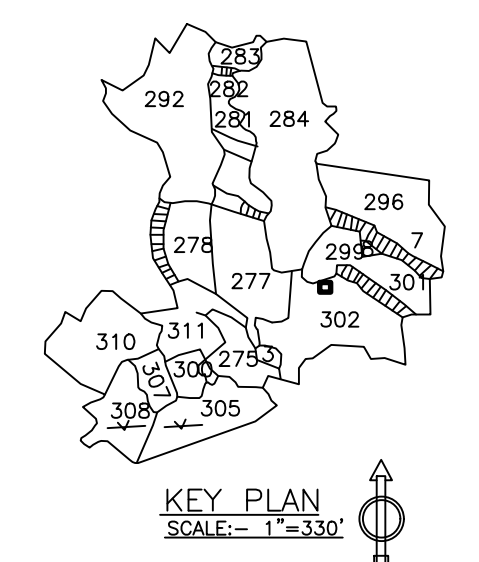
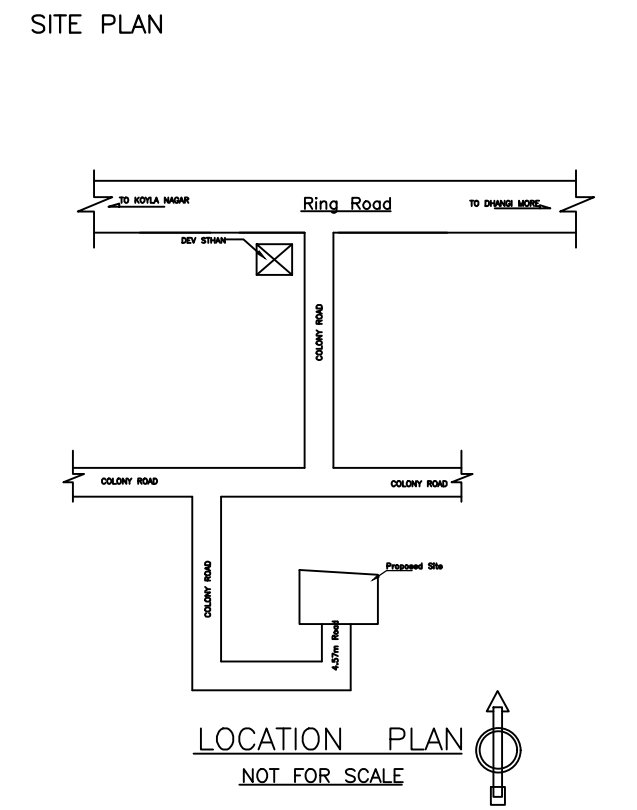

SCHEDULE OF DOOR:

BUILDING NAME	NAME	LENGTH	HEIGHT	NOS
A (SRI SANTOSH KUMAR GOSWAMI)	D2	0.75	2.10	04
A (SRI SANTOSH KUMAR GOSWAMI)	D1	0.90	2.10	02
A (SRI SANTOSH KUMAR GOSWAMI)	D	1.00	2.10	06

SCHEDULE OF WINDOW/VENTILATION:

BUILDING NAME	NAME	LENGTH	HEIGHT	NOS
A (SRI SANTOSH KUMAR GOSWAMI)	V	0.60	0.60	04
A (SRI SANTOSH KUMAR GOSWAMI)	W1	0.90	1.20	06
A (SRI SANTOSH KUMAR GOSWAMI)	W	1.20	1.20	10

Building :A (SRI SANTOSH KUMAR GOSWAMI)

Floor Name	Total Built Up Area (Sq.mt.)	Proposed FAR Area (Sq.mt.) Res.	Total FAR Area (Sq.mt.)	Total Consumed Additional FAR Area (Sq.mt.)	Tnmt (No.)
Ground Floor	60.01	60.01	60.01	60.01	01
First Floor	60.01	60.01	60.01	60.01	00
Terrace Floor	0.00	0.00	0.00	0.00	00
Total:	120.02	120.02	120.02	120.02	01
Total Number of Same Buildings	1				
Total:	120.02	120.02	120.02	120.02	01

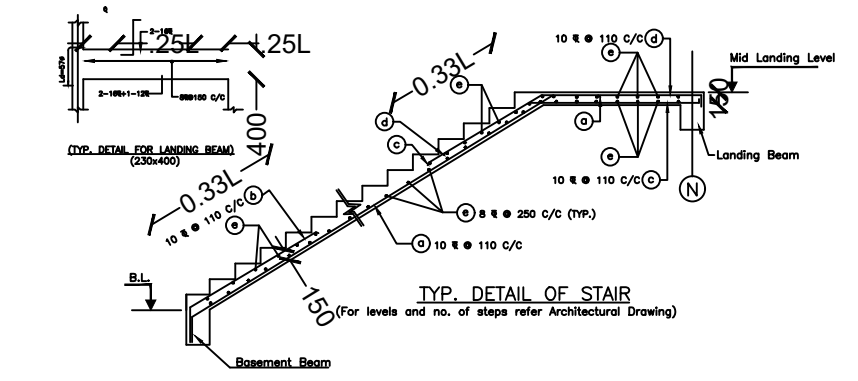
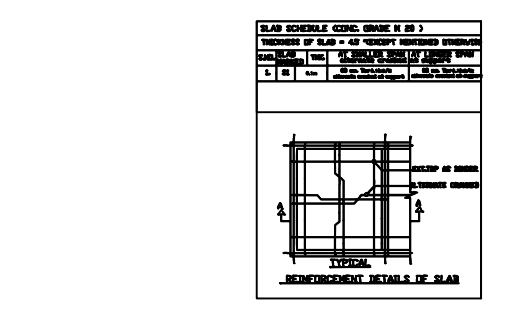
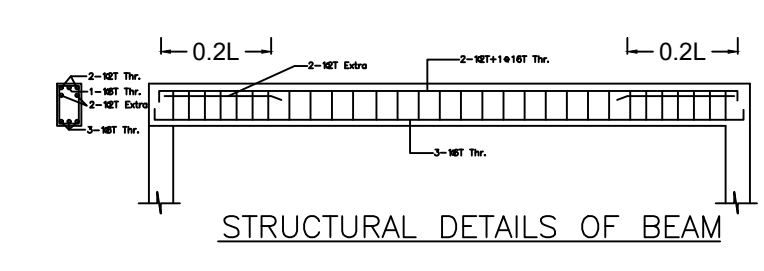
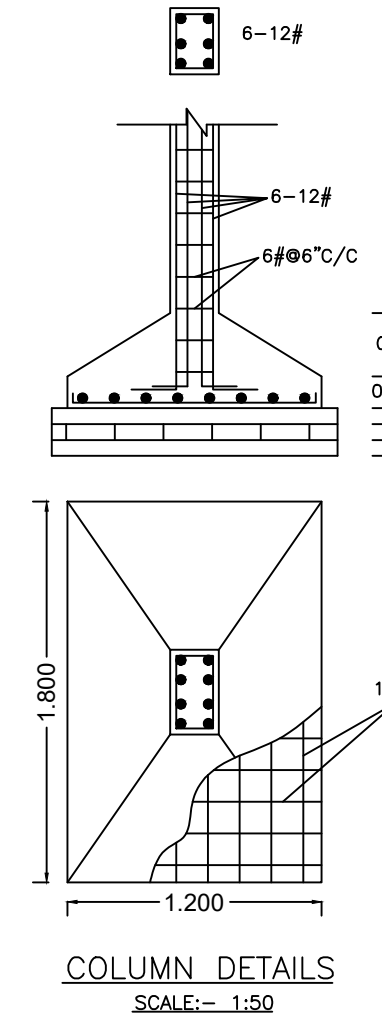
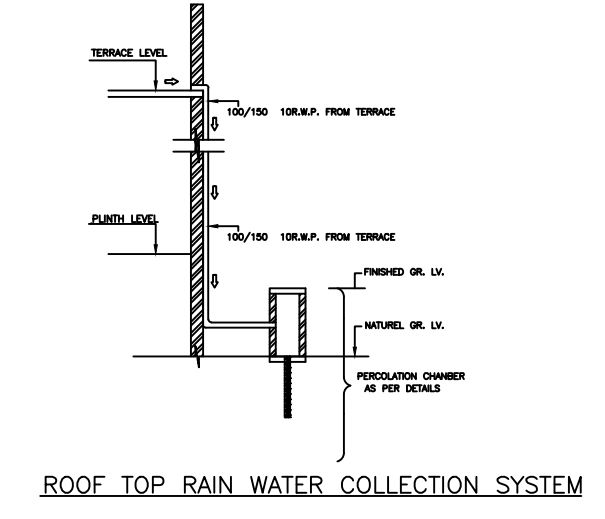
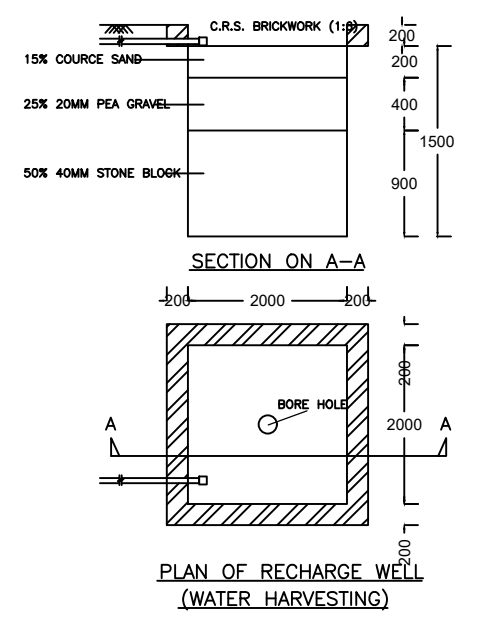
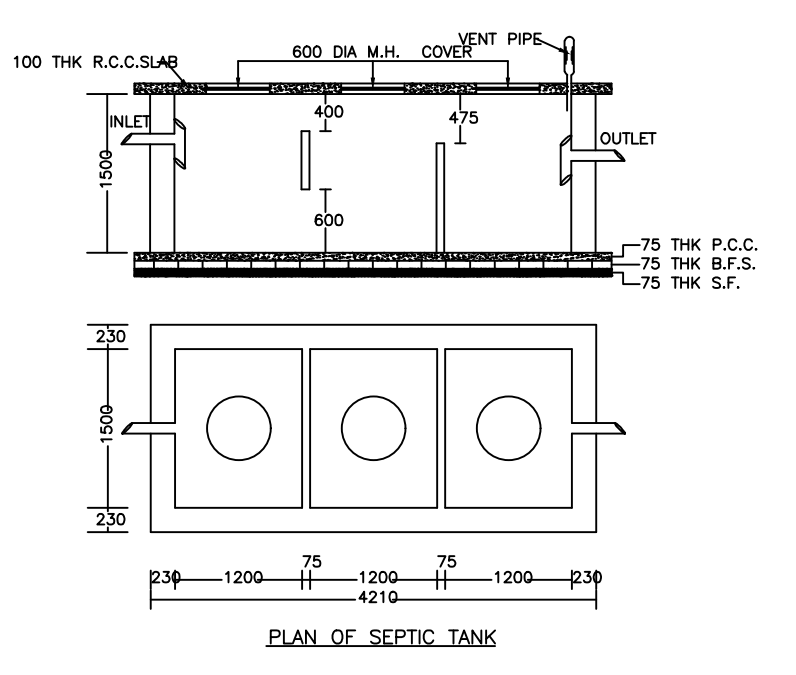

Color	Description
Black	PLOT BOUNDARY
Green	ABUTTING ROAD
Red	PROPOSED CONSTRUCTION
Yellow	COMMON PLOT
Blue	ROAD WIDENING AREA
White	EXISTING (To be retained)
Grey	EXISTING (To be demolished)

Floor Name	Building Name		Total	
	A (SRI SANTOSH KUMAR GOSWAMI) Proposed Built Up Area (Sq.mt.)	Proposed FAR Area (Sq.mt.)	Total Proposed Built Up Area (Sq.mt.)	Total FAR Area (Sq.mt.)
Ground Floor	60.01	60.01	60.01	60.01
First Floor	60.01	60.01	60.01	60.01
Terrace Floor	0.00	0.00	0.00	0.00
Total:	120.02	120.02	120.02	120.02

FLOOR	Building Name		Building Use		Building SubUse		Building Structure	
	Name	UnitBUA Type	UnitBUA Area	Carpet Area	No. of Rooms	No. of Tenement		
GROUND FLOOR PLAN	SPLIT 1	FLAT	120.02	119.85	6	1		
FIRST FLOOR PLAN	SPLIT 1	FLAT	0.00	0.00	6	0		
Total:	-	-	120.02	119.85	12	1		

Building	No. of Same Bldg	Total Built Up Area (Sq.mt.)	Proposed FAR Area (Sq.mt.) Res.	Total FAR Area (Sq.mt.)	Total Consumed Additional FAR Area (Sq.mt.)	Tnmt (No.)
A (SRI SANTOSH KUMAR GOSWAMI)	1	120.02	120.02	120.02	120.02	01
Grand Total:	1	120.02	120.02	120.02	120.02	01

LTP NAME AND SIGNATURE	STRUCTURAL ENG'S NAME AND SIGNATURE	BUILDER NAME AND SIGNATURE	DIGITAL SIGNATURE
Piyush Kanti Singh MADA/ENG/0012/2019			

Proposal Basic Information

Proposal File No.	MADA/BP/0081/2021
Owner Name	SRI. SANTOSH KUMAR GOSWAMI
Khata No	07 (OLD) , New Khata No - 20
Plot No	302 (OLD) , NEW PLOT NO. - 529
Village Name	Narayanpur
Use	Residential
SubUse	Bungalow/ Dwelling / Non Apartment

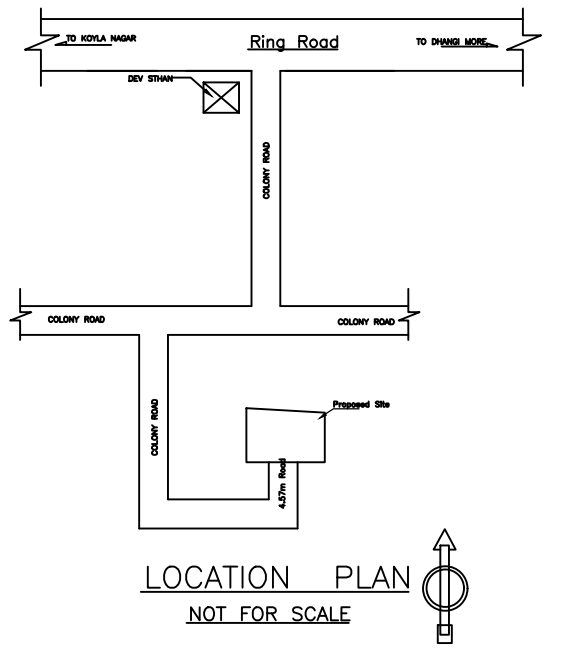
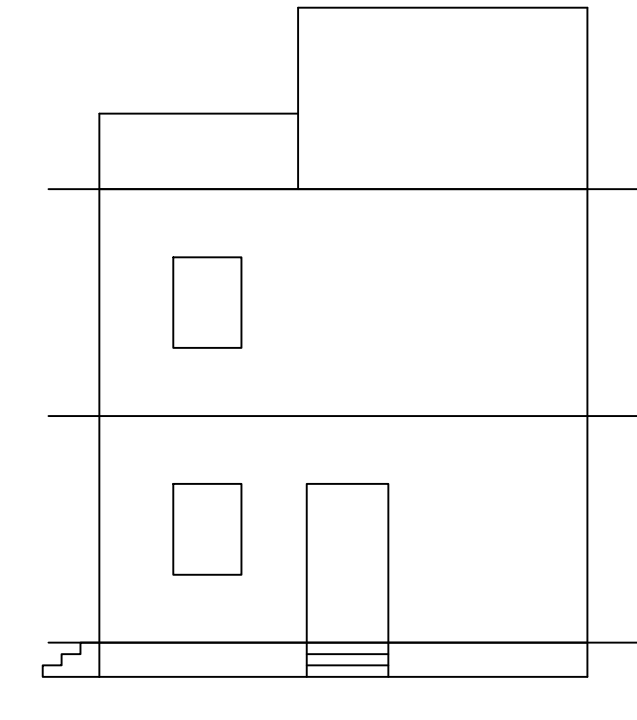
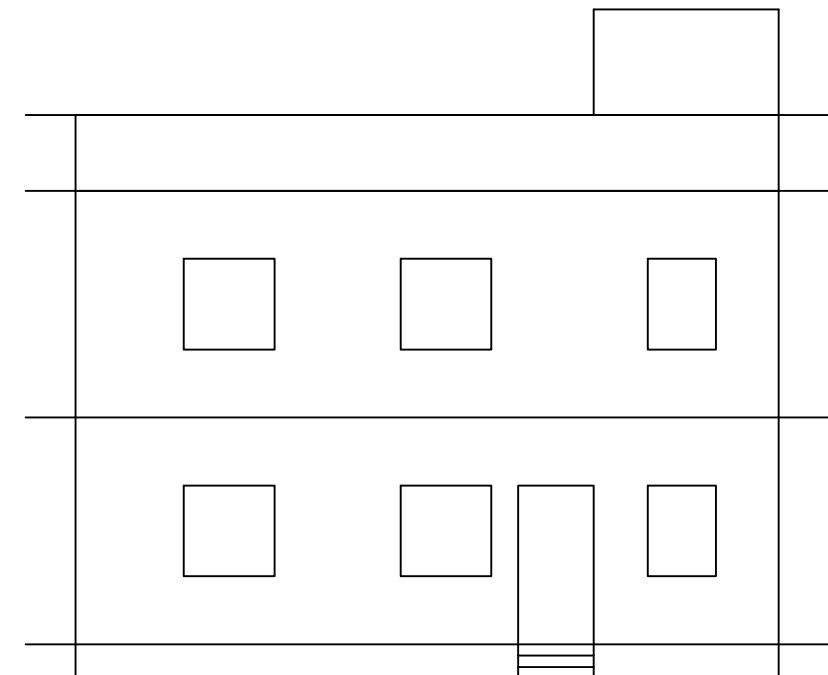
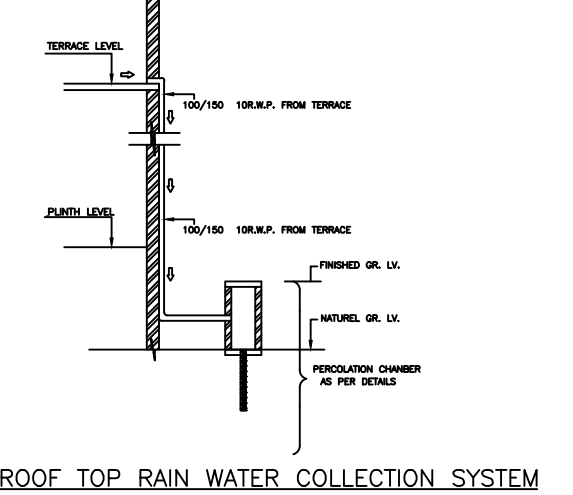
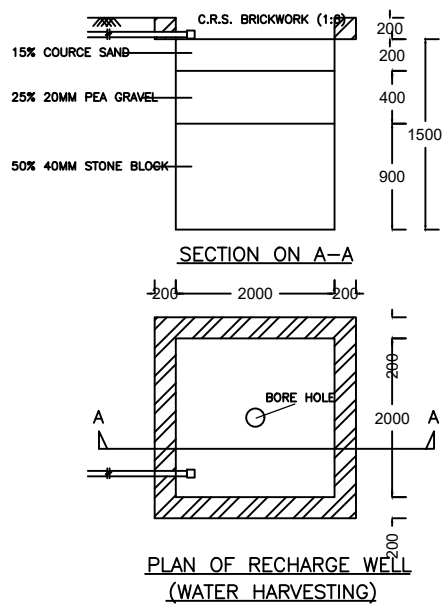
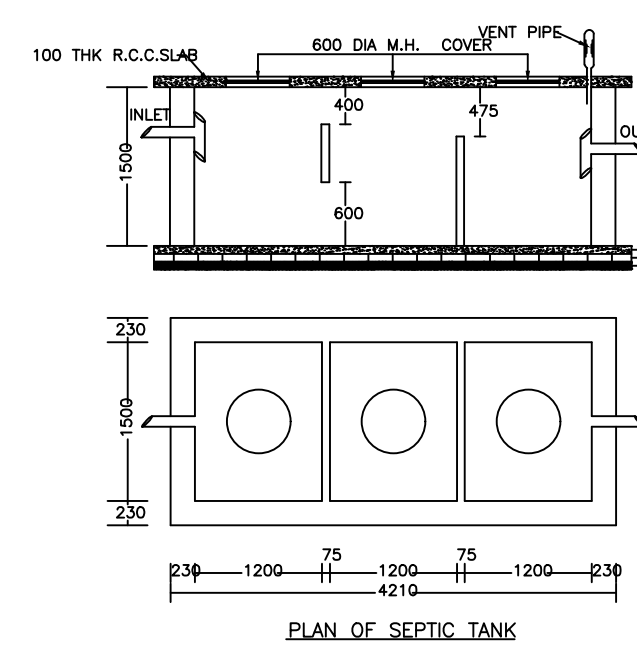
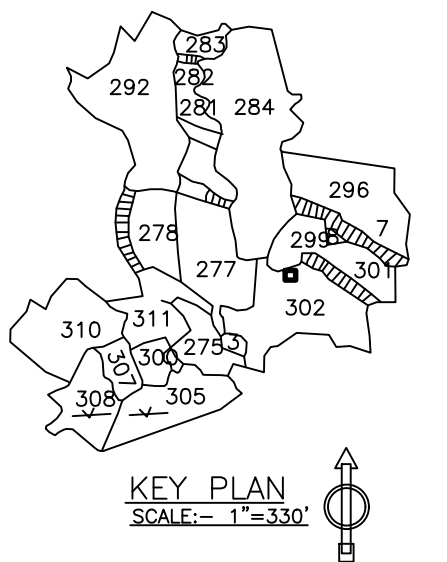
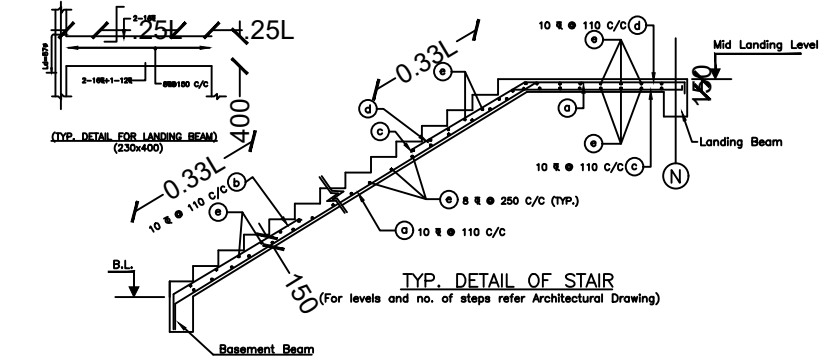
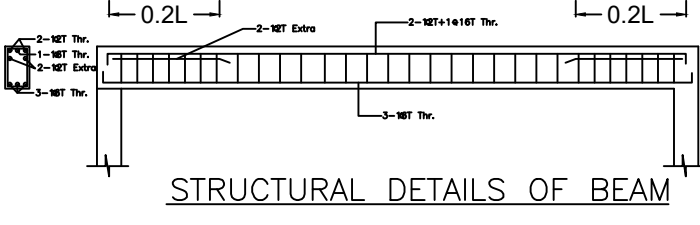
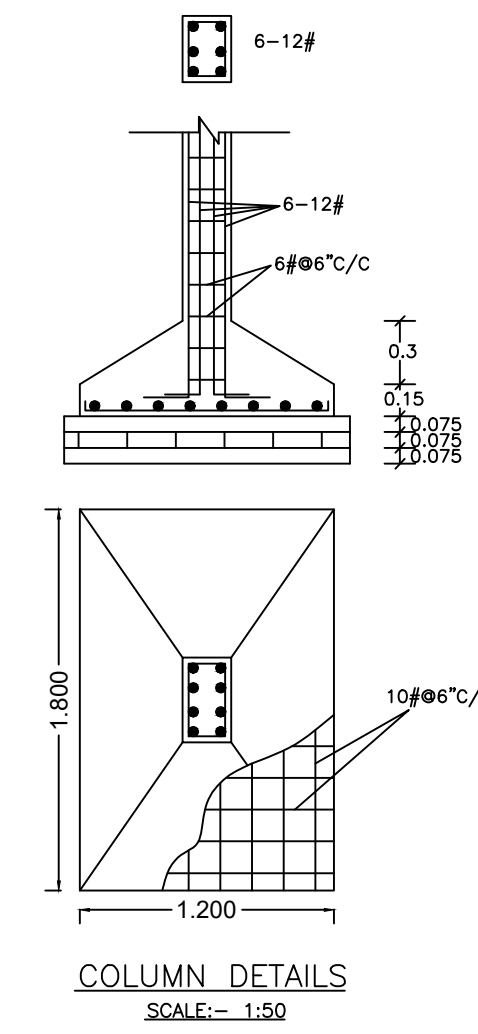
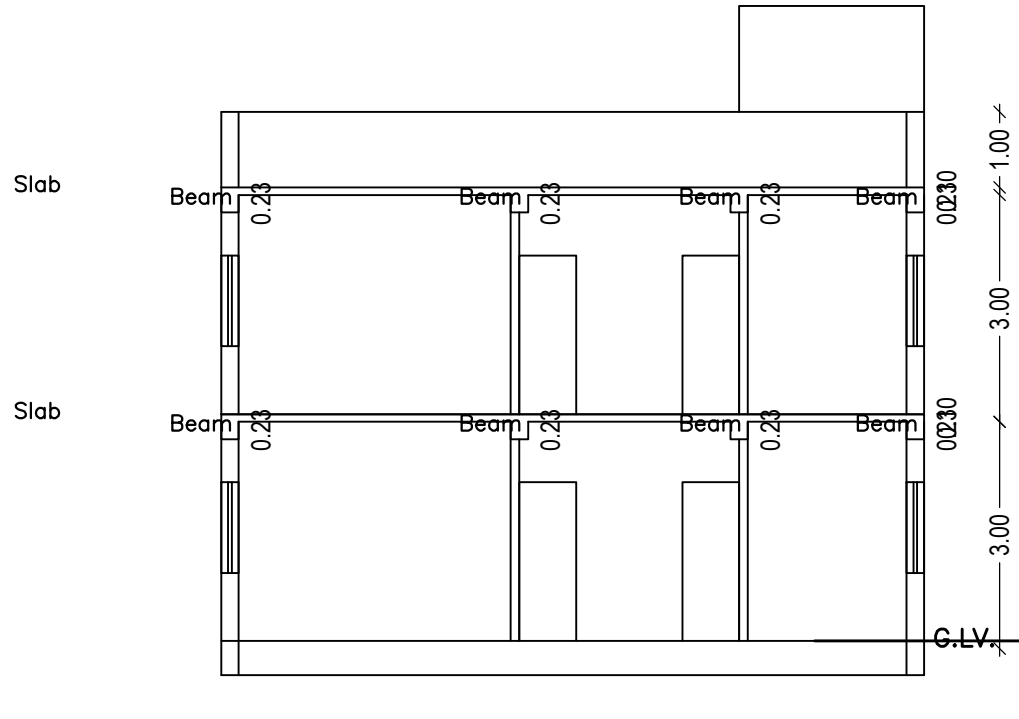
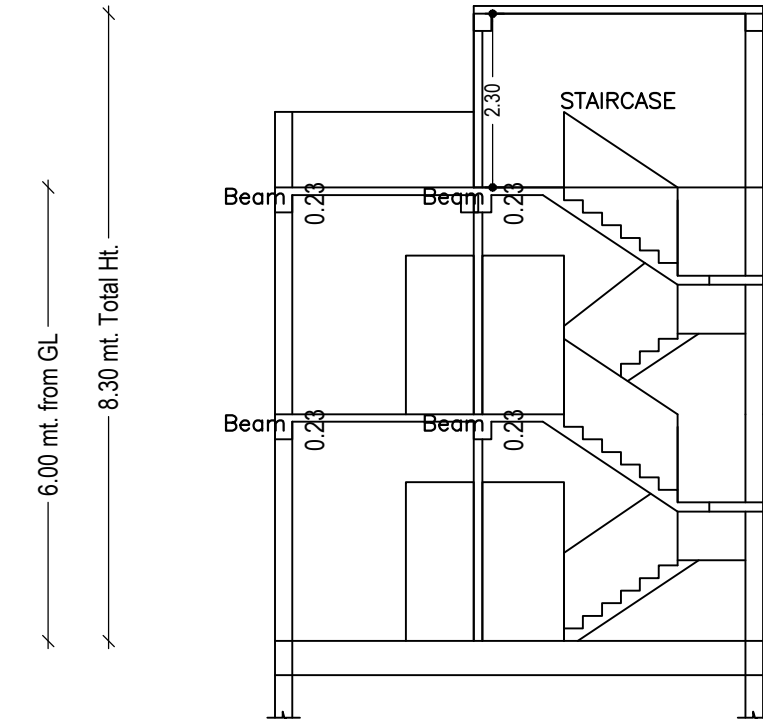
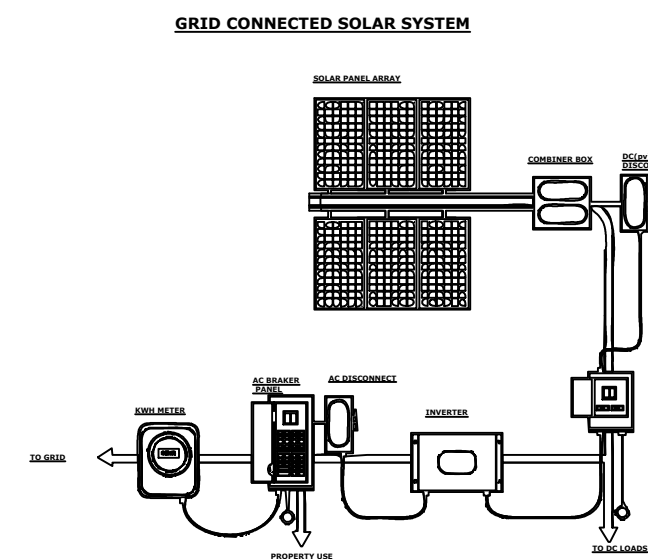
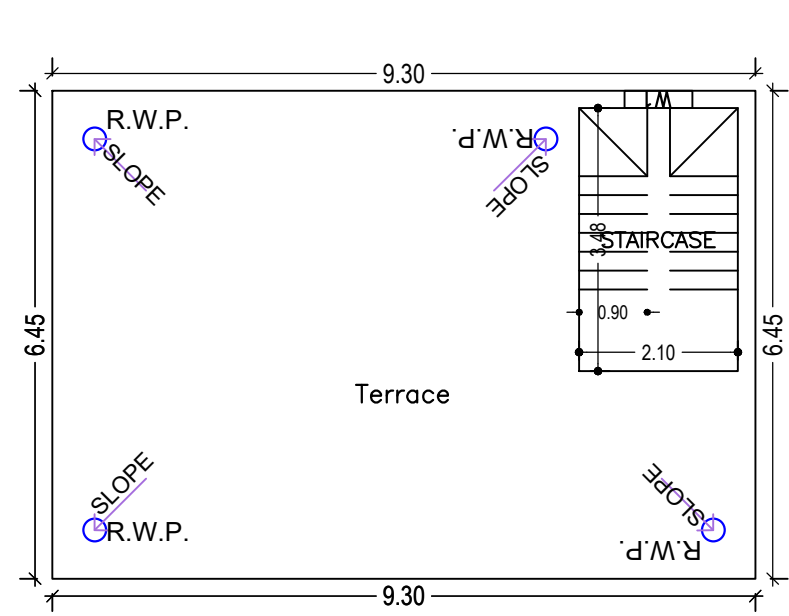
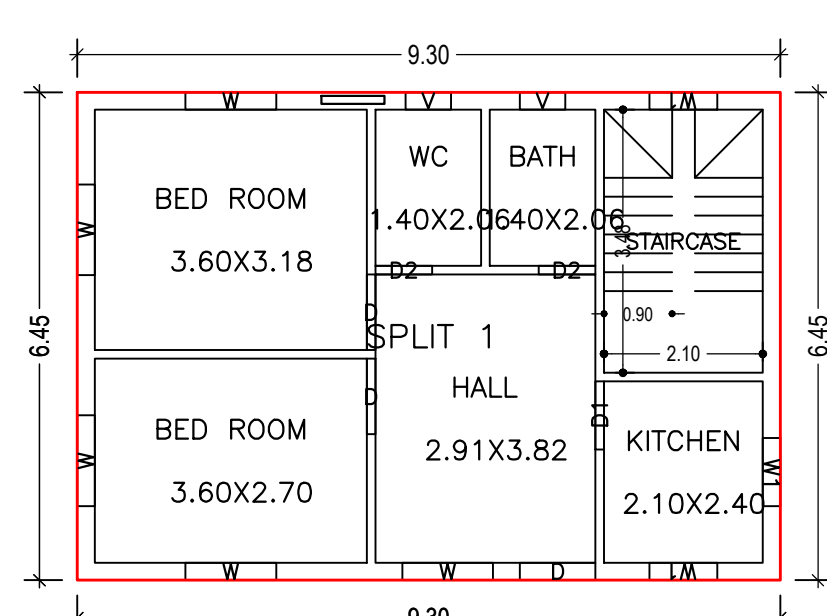
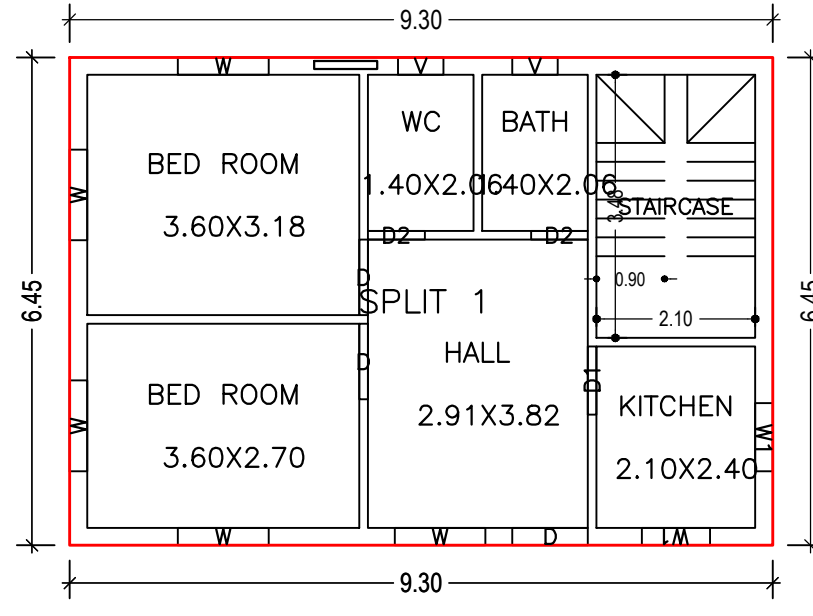

LTP NAME AND SIGNATURE	STRUCTURAL ENG'S NAME AND SIGNATURE	BUILDER NAME AND SIGNATURE	DIGITAL SIGNATURE
Piyush Kanti Singh MADA/ENG/0012/2019			