

SCHEDULE OF DOOR:

BUILDING NAME	NAME	LENGTH	HEIGHT	NOS
A (JAIPRAKASH)	D	0.84	2.10	01
A (JAIPRAKASH)	D	0.90	2.10	12
A (JAIPRAKASH)	d	0.90	2.10	01
A (JAIPRAKASH)	D	0.91	2.10	01

SCHEDULE OF WINDOW/VENTILATION:

BUILDING NAME	NAME	LENGTH	HEIGHT	NOS
A (JAIPRAKASH)	W	1.19	1.20	04
A (JAIPRAKASH)	W	1.80	1.20	14
A (JAIPRAKASH)	W	2.63	1.20	01
A (JAIPRAKASH)	W	3.28	1.20	01

Building :A (JAIPRAKASH)

Floor Name	Total Built Up Area (Sq.mt.)	Proposed FAR Area (Sq.mt.)	Total FAR Area (Sq.mt.)	Total Consumed Additional FAR Area (Sq.mt.)	Tnmt (No.)
Ground Floor	89.30	89.30	89.30	89.30	01
First Floor	89.30	89.30	89.30	89.30	00
Terrace Floor	0.00	0.00	0.00	0.00	00
Total	178.60	178.60	178.60	178.60	01
Total Number of Same Buildings	1				
Total	178.60	178.60	178.60	178.60	01

Proposal Basic Information

Proposal File No.	MADA/BP/0001/2021
Owner Name	SRI. JAI PRAKASH
Khata No.	OLD KHATA NO 69, NEW KHATA NO 134
Plot No.	OLD PLOT NO 518, NEW PLOT NO 1456
Village Name	Jialgora
Use	Residential
SubUse	Bungalow/ Dwelling / Non Apartment

AREA STATEMENT MINERAL

AREA OF PLOT (Minimum)	(A)	SQ.MT.
NET AREA OF PLOT (Gross Plot Area - Deduction from Gross Plot area)	(A-Deductions)	146.02
Deduction for Balance Plot Area (from Gross Plot Area)		
Common Plot		22.66
Total		22.66
BALANCE AREA OF PLOT (Net Plot Area - Recreational/Amenity space)	(A-Deductions)	123.36
PLOT AREA FOR COVERAGE (Net Plot Area)	(A-Deductions)	146.02
Plot Area for FAR (Net Plot Area + Road Widening Area)	(A-Deductions)	146.02
COVERAGE CHECK		
Permissible Coverage area (70.00 %)		102.21
Proposed Coverage Area (61.16 %)		89.30
Total Prop. Coverage Area (61.16 %)		89.30
Balance coverage area (8.84 %)		12.91
FAR CHECK		
Perm. FAR Area (2.50)		365.05
Total Perm. FAR area		365.05
Residential FAR		178.60
Proposed FAR Area		178.60
Total Proposed FAR Area		178.60
Consumed FAR (Factor)		1.22
Balance FAR Area		186.45
BUILT UP AREA CHECK		
Total Proposed BuiltUp Area		178.60
ARCHITECT (Regd)		
ARCHITECT (Regd)		RAM PRATAP SINGH
ENGINEER (Regd)		
ENGINEER (Regd)		
SUPERVISOR (Regd)		
SUPERVISOR (Regd)		
OWNER (Regd)		
OWNER (Regd)		SRI. JAI PRAKASH
DEVELOPMENT AUTHORITY		
DEVELOPMENT AUTHORITY		LOCAL BODY

COLOR INDEX

PLOT BOUNDARY	Black
ABUTTING ROAD	Green
PROPOSED CONSTRUCTION	Red
COMMON PLOT	Yellow
ROAD WIDENING AREA	Blue
EXISTING (To be retained)	Orange
EXISTING (To be demolished)	Light Blue

Buildingwise Floor FAR Details

Floor Name	Building Name A (JAIPRAKASH)		Total	
	Proposed Built Up Area (Sq.mt.)	Proposed FAR Area (Sq.mt.)	Total Proposed Built Up Area (Sq.mt.)	Total FAR Area (Sq.mt.)
Ground Floor	89.30	89.30	89.30	89.30
First Floor	89.30	89.30	89.30	89.30
Terrace Floor	0.00	0.00	0.00	0.00
Total	178.60	178.60	178.60	178.60

Building USE/SUBUSE Details

Building Name	Building Use	Building SubUse	Building Structure
A (JAIPRAKASH)	Residential	Residential Bldg/Apartment	Non-Highrise

FAR & Tenement Details (Table 4c-1)

Building	No. of Same Bldg	Total Built Up Area (Sq.mt.)	Proposed FAR Area (Sq.mt.)	Total FAR Area (Sq.mt.)	Total Consumed Additional FAR Area (Sq.mt.)	Tnmt (No.)
A (JAIPRAKASH)	1	178.60	178.60	178.60	178.60	01
Grand Total:	1	178.60	178.60	178.60	178.60	01

UnitBUA Table for Building :A (JAIPRAKASH)

FLOOR	Name	UnitBUA Type	UnitBUA Area	Carpet Area	No. of Rooms	No. of Tenement
GROUND FLOOR PLAN	SPLIT 1	FLAT	178.60	178.55	7	1
FIRST FLOOR PLAN	SPLIT 1	FLAT	0.00	0.00	8	0
Total:	-	-	178.60	178.55	15	1

LTP NAME AND SIGNATURE	STRUCTURAL ENG'S NAME AND SIGNATURE	BUILDER NAME AND SIGNATURE	DIGITAL SIGNATURE
RAM PRATAP SINGH MADA/ARC/0024/2019			

Proposal Basic Information

Proposal File No.	MADA/BP/0001/2021
Owner Name	SRI. JAI PRAKASH
Khata No	OLD KHATA NO 69, NEW KHATA NO 134
Plot No	OLD PLOT NO 518, NEW PLOT NO 1456
Village Name	Jialgora
Use	Residential
SubUse	Bungalow/ Dwelling / Non Apartment

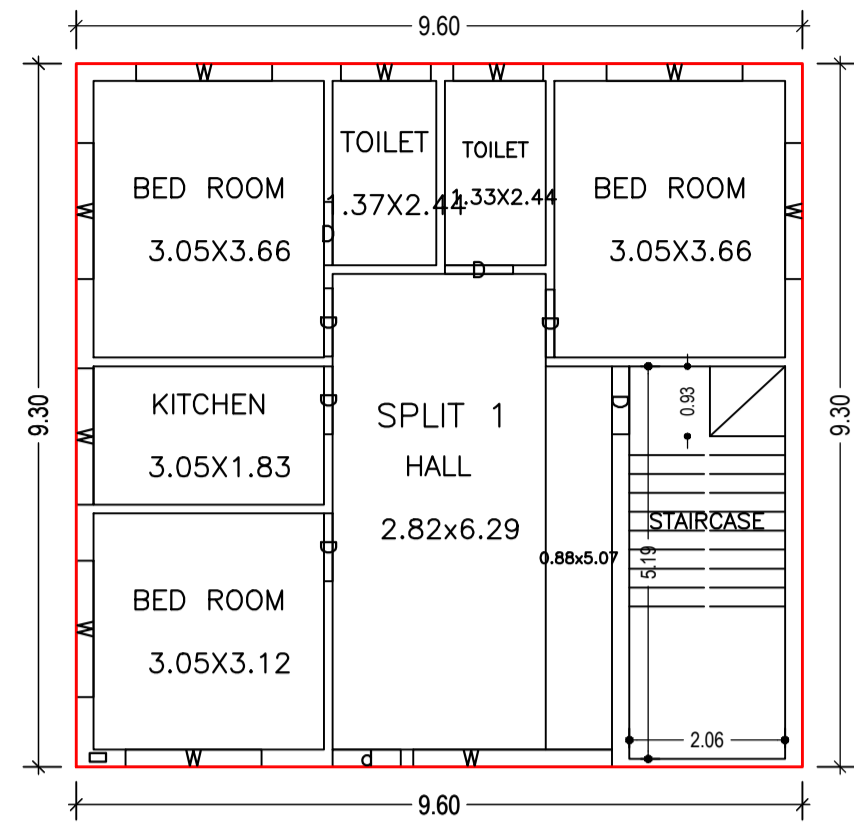

GROUND FLOOR PLAN
(Proposed)
(SCALE 1:100)

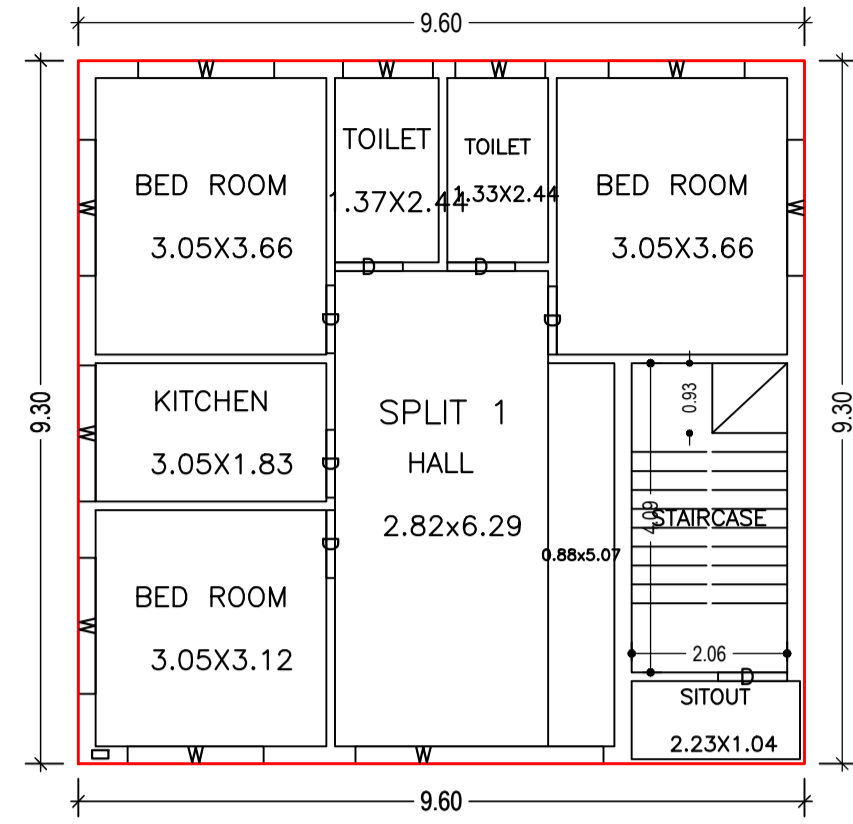

FIRST FLOOR PLAN
(Proposed)
(SCALE 1:100)

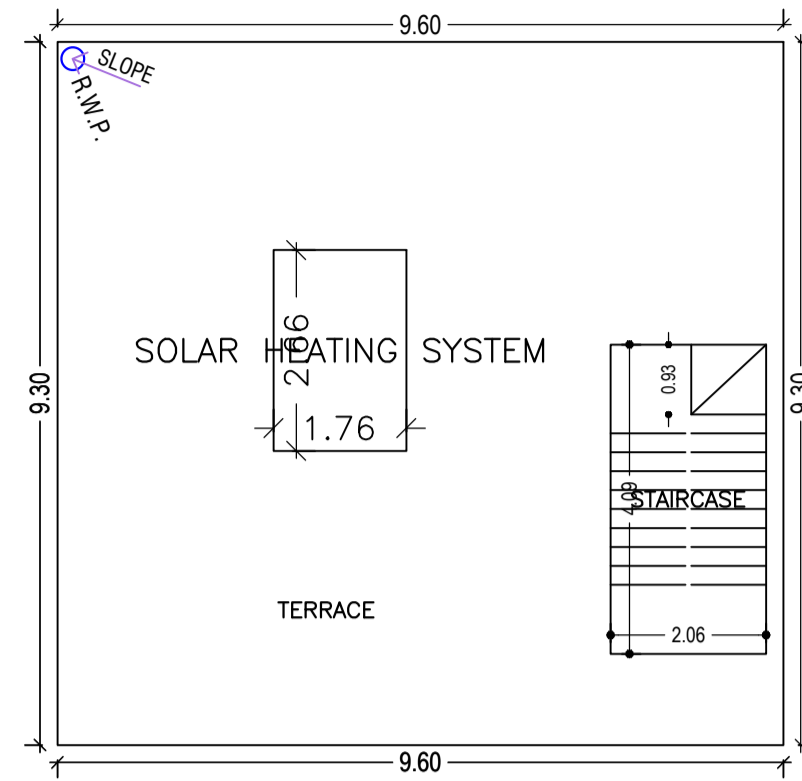

TERRACE FLOOR PLAN
(SCALE 1:100)

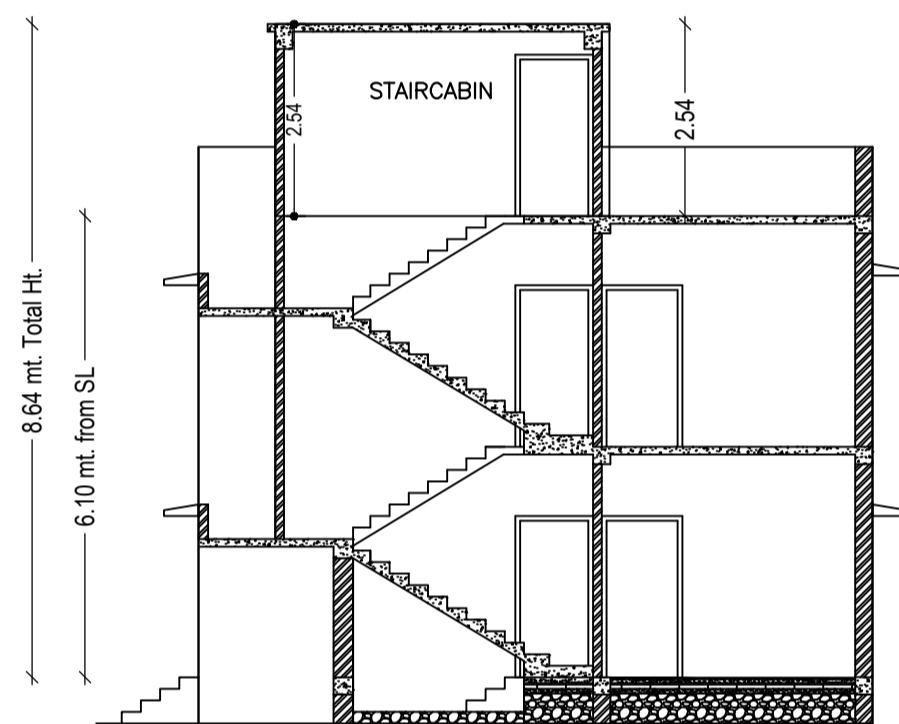
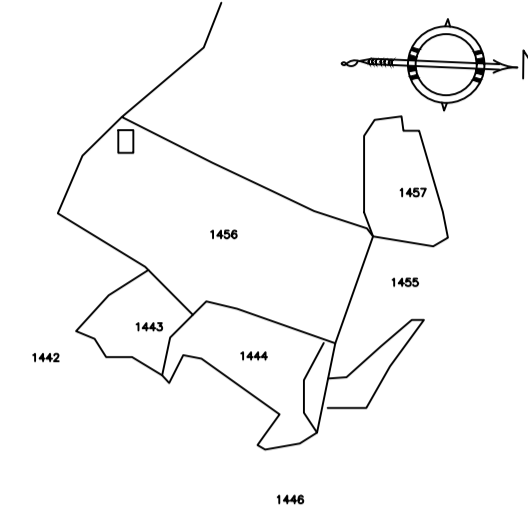
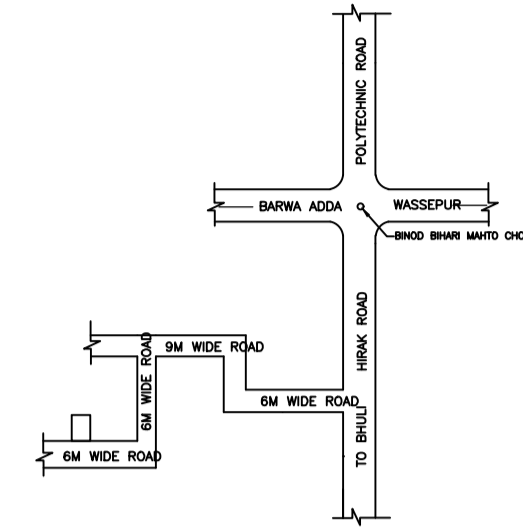

SECTION ON X-X

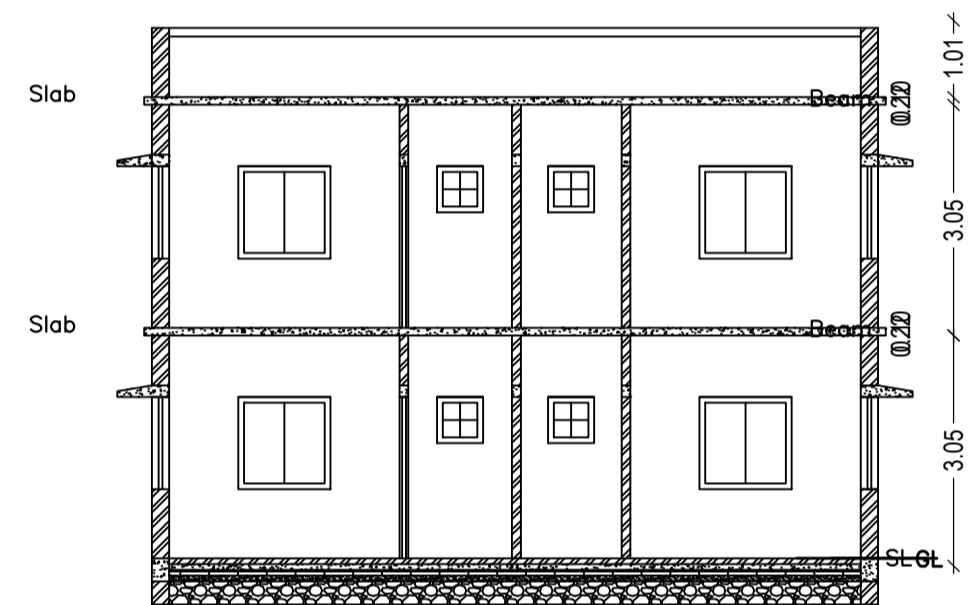

SECTION - YY'

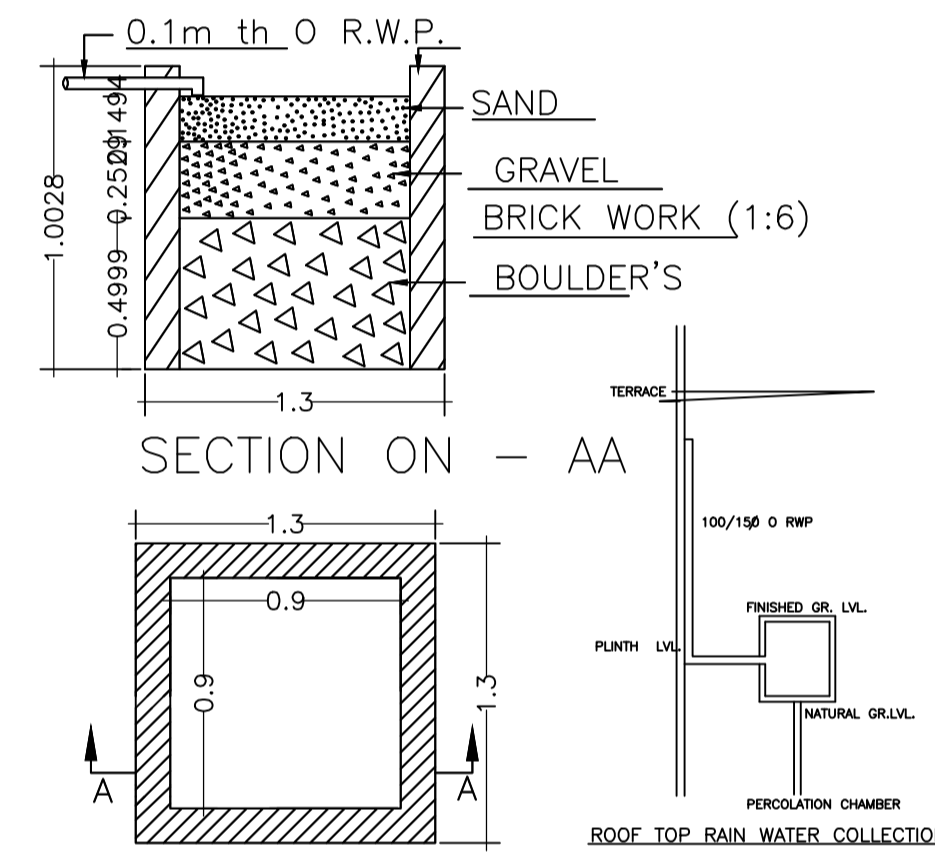

DETAIL'S OF WATER HARVESTING

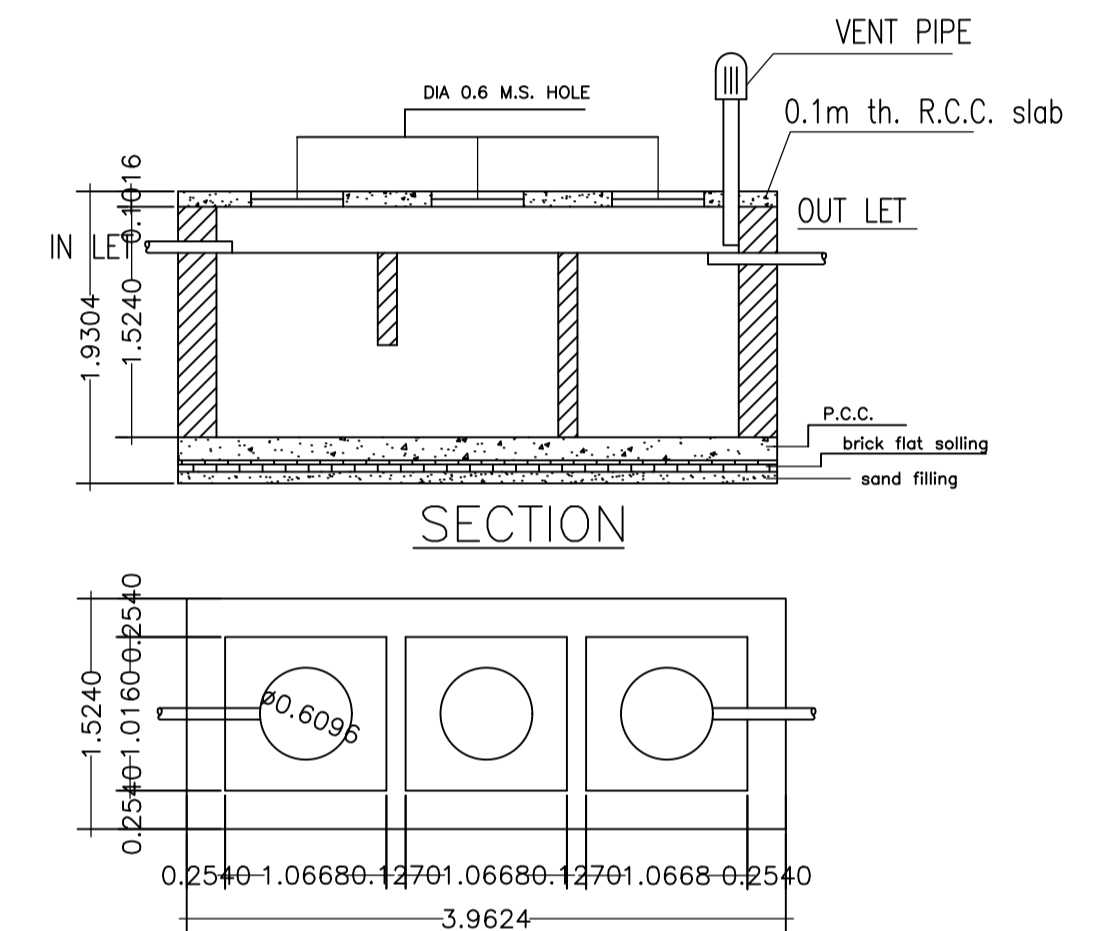

DETAILS OF SEPTIC TANK

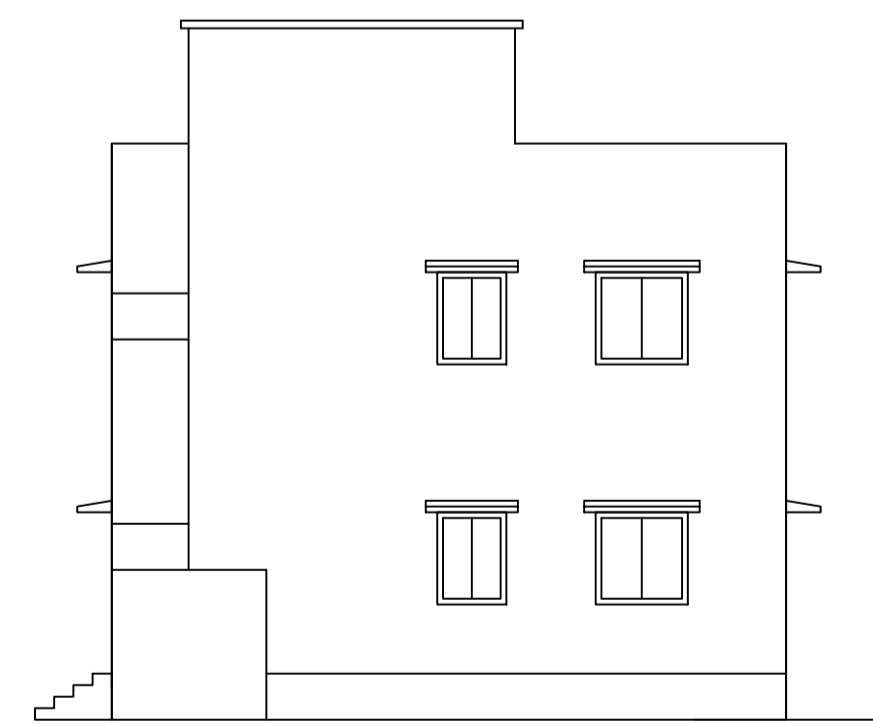

RIGHT ELEVATION

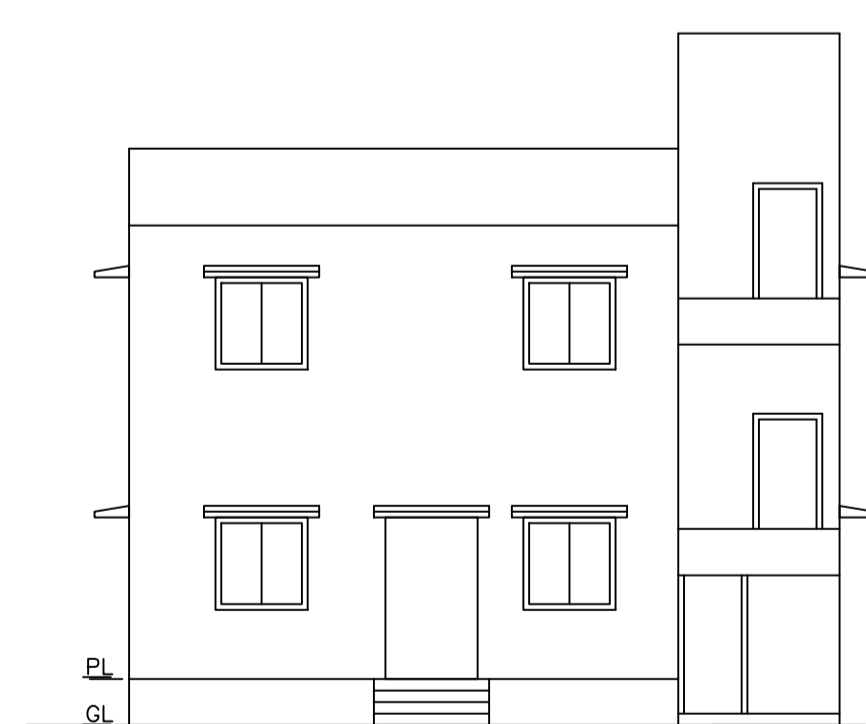

FRONT ELEVATION

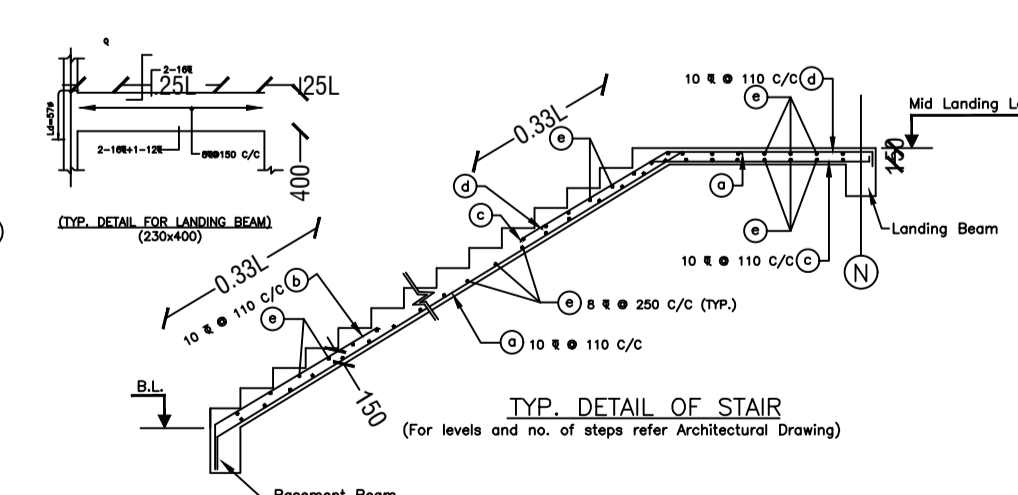
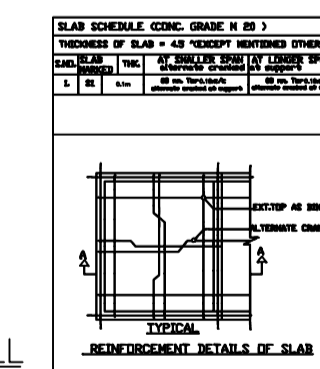
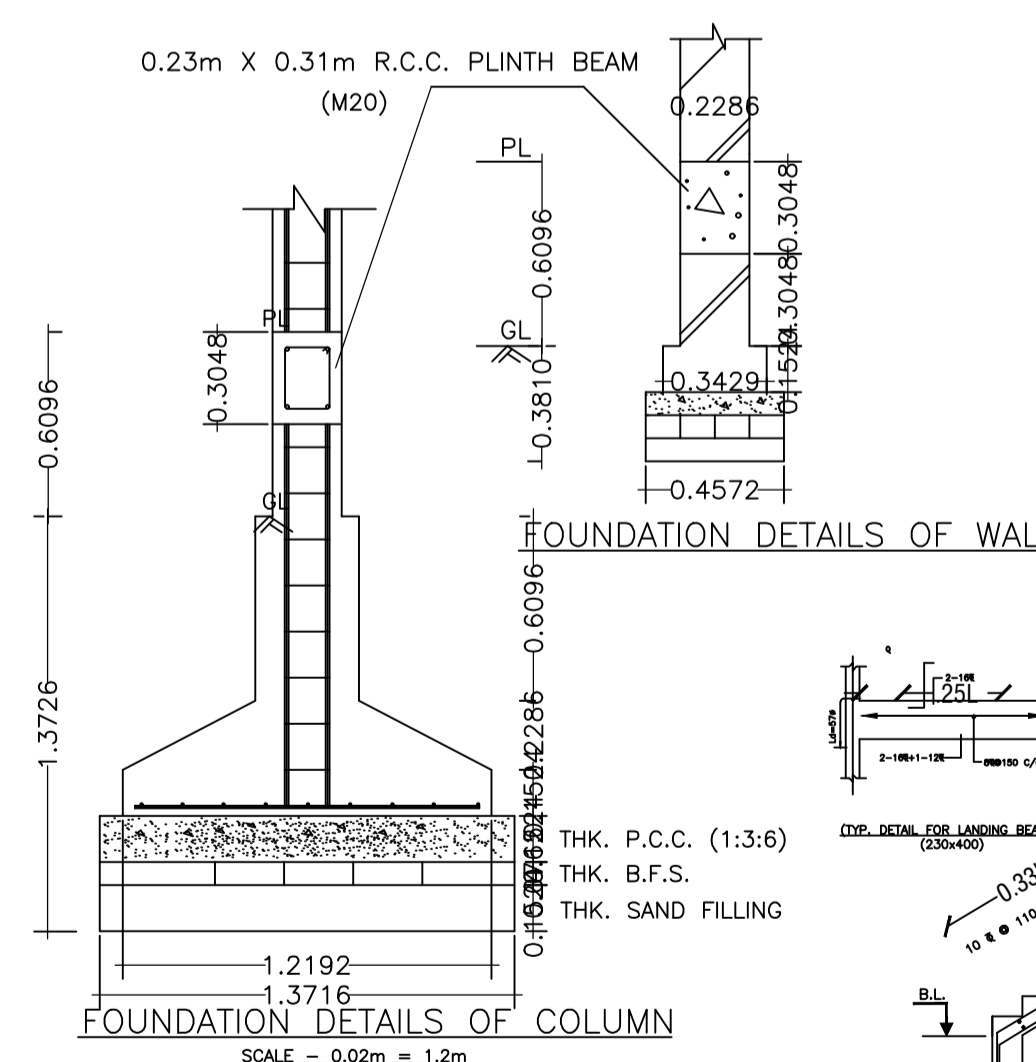

LTP NAME AND SIGNATURE	STRUCTURAL ENG'S NAME AND SIGNATURE	BUILDER NAME AND SIGNATURE	DIGITAL SIGNATURE
RAM PRATAP SINGH MADA/ARC/0024/2019			