

SCHEDULE OF DOOR:

BUILDING NAME	NAME	LENGTH	HEIGHT	NOS
A (A)	D	0.76	2.10	06
A (A)	D	0.91	2.10	02
A (A)	D	1.07	2.10	02
A (A)	D	1.10	2.10	05

SCHEDULE OF WINDOW/VENTILATION:

BUILDING NAME	NAME	LENGTH	HEIGHT	NOS
A (A)	V	0.61	1.20	06
A (A)	W	0.62	1.20	01
A (A)	W	0.74	1.20	01
A (A)	W	0.91	1.20	02
A (A)	W	1.22	1.20	14

Building :A (A)

Floor Name	Total Built Up Area (Sq.mt.)	Proposed FAR Area (Sq.mt.) Res.	Total FAR Area (Sq.mt.)	Total Consumed Additional FAR Area (Sq.mt.)	Tnmt (No.)
Ground Floor	99.78	99.78	99.78	99.78	01
First Floor	99.78	99.78	99.78	99.78	00
Terrace Floor	0.00	0.00	0.00	0.00	00
Total:	199.56	199.56	199.56	199.56	01
Total Number of Same Buildings	1				
Total:	199.56	199.56	199.56	199.56	01

Proposal Basic Information

Proposal File No.	MADA/BP/0007/2021
Owner Name	MINA DEVI
Khata No	OLD-95 NEW-296
Plot No	OLD-961 AND 963, NEW-1856
Village Name	Damodarpur
Use	Residential
SubUse	Bungalow/ Dwelling / Non Apartment

AREA STATEMENT MINERAL AREA DEVELOPMENT AUTHORITY	VERSION NO.: 1.0.53	VERSION DATE: 16/10/2020
PROJECT DETAIL:	Region: JHARKHAND URBAN LOCAL BODIES	Plot Use: Residential
District: DHANBAD	Plot SubUse: Bungalow/ Dwelling / Non Apartment	
Authority: MINERAL AREA DEVELOPMENT AUTHORITY	PlotNearby/ReligiousStructure: NA	
Inward No: MADA/BP/0007/2021	Plot/SubPlot No: OLD-961 AND 963, NEW-1856	
Application Type: General Proposal	North: Plot No. - JAI PRAKASH THAKUR	
Project Type: Building Permission	South: Plot No. - SMT ANJALI NAG	
Nature of Development: New	East: Plot No. - 3.66 M WIDE ROAD	
Location of Development Area: Old Area	West: Plot No. - SMT SAKUNI DEVI	
AREA DETAILS:		SQ.MT.
AREA OF PLOT (Minimum)	(A)	161.47
NET AREA OF PLOT(Gross Plot Area - Deduction from Gross Plot area)	(A-Deductions)	161.47
Deduction for Balance Plot Area(from Gross Plot Area)		
Common Plot		9.35
Total		9.35
BALANCE AREA OF PLOT(Net Plot Area - Recreational/Amenity space)	(A-Deductions)	152.12
PLOT AREA FOR COVERAGE(Net Plot Area)	(A-Deductions)	161.47
Plot Area for FAR (Net Plot Area + Road Widening Area)	(A-Deductions)	161.47
COVERAGE CHECK		
Permissible Coverage area (70.00 %)		113.03
Proposed Coverage Area (61.80 %)		99.78
Total Prop. Coverage Area (61.8 %)		99.78
Balance coverage area (8.21 %)		13.25
FAR CHECK		
Perm. FAR Area (1.50)		242.21
Total Perm. FAR area		242.21
Residential FAR		199.56
Proposed FAR Area		199.56
Total Proposed FAR Area		199.56
Consumed FAR (Factor)		1.24
Balance FAR Area		42.65
BUILT UP AREA CHECK		
Total Proposed BuiltUp Area		199.56
ARCHITECT (Regd)	SANJEEV KUMAR RAY	
ENGINEER (Regd)		
SUPERVISOR (Regd)		
OWNER (Regd)	MINA DEVI	
DEVELOPMENT AUTHORITY		LOCAL BODY

Color	Description
Black	PLOT BOUNDARY
Green	ABUTTING ROAD
Red	PROPOSED CONSTRUCTION
Yellow	COMMON PLOT
Blue	ROAD WIDENING AREA
Light Blue	EXISTING (To be retained)
Dark Blue	EXISTING (To be demolished)

Buildingwise Floor FAR Details

Floor Name	Building Name A (A)		Total	
	Proposed Built Up Area (Sq.mt.)	Proposed FAR Area (Sq.mt.)	Total Proposed Built Up Area (Sq.mt.)	Total FAR Area (Sq.mt.)
Ground Floor	99.78	99.78	99.78	99.78
First Floor	99.78	99.78	99.78	99.78
Terrace Floor	0.00	0.00	0.00	0.00
Total:	199.56	199.56	199.56	199.56

Building USE/SUBUSE Details

Building Name	Building Use	Building SubUse	Building Structure
A (A)	Residential	Residential Bldg/Apartment	Non-Highrise

FAR & Tenement Details (Table 4c-1)

Building	No. of Same Bldg	Total Built Up Area (Sq.mt.)	Proposed FAR Area (Sq.mt.) Res.	Total FAR Area (Sq.mt.)	Total Consumed Additional FAR Area (Sq.mt.)	Tnmt (No.)
A (A)	1	199.56	199.56	199.56	199.56	01
Grand Total:	1	199.56	199.56	199.56	199.56	01

UnitBUA Table for Building :A (A)

FLOOR	Name	UnitBUA Type	UnitBUA Area	Carpet Area	No. of Rooms	No. of Tenement
GROUND FLOOR PLAN	SPLIT A	FLAT	199.56	199.43	7	1
FIRST FLOOR PLAN	SPLIT A	FLAT	0.00	0.00	8	0
Total:	-	-	199.56	199.43	15	1

LTP NAME AND SIGNATURE	STRUCTURAL ENG'S NAME AND SIGNATURE	BUILDER NAME AND SIGNATURE	DIGITAL SIGNATURE
SANJEEV KUMAR RAY MADA/ENG/0021/2019			

Proposal Basic Information	
Proposal File No.	MADA/BP/007/2021
Owner Name	MINA DEVI
Khata No	OLD-95 NEW-296
Plot No	OLD-961 AND 963, NEW-1856
Village Name	Damodarpur
Use	Residential
SubUse	Bungalow/ Dwelling / Non Apartment

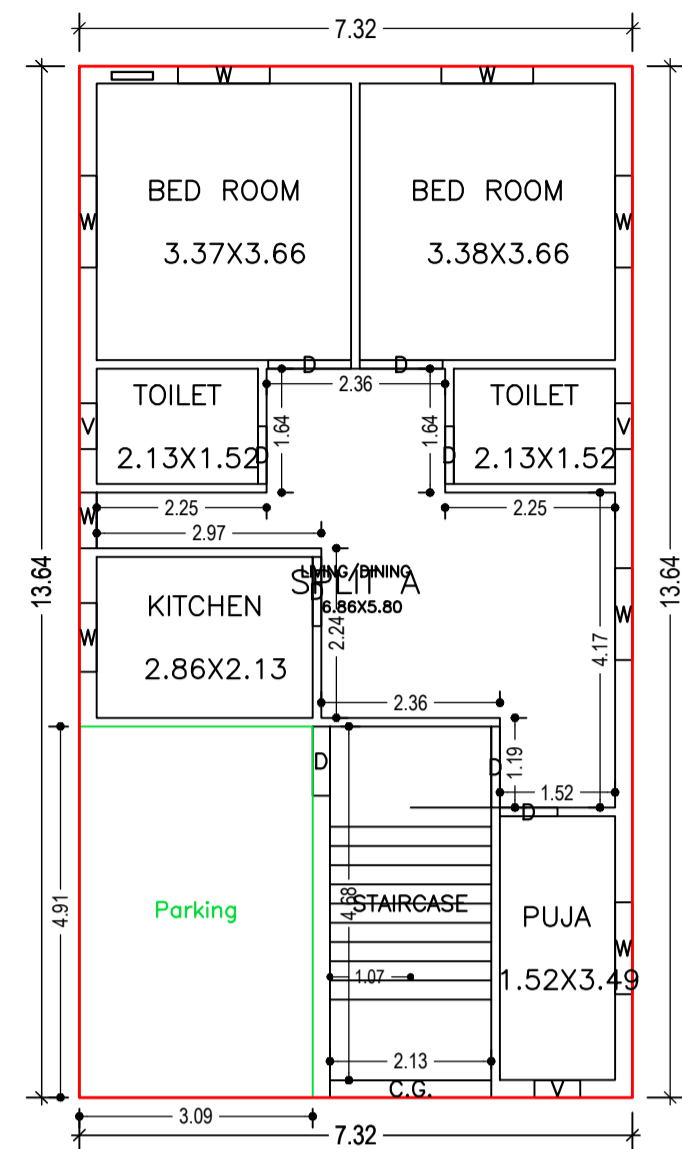

GROUND FLOOR PLAN
(Proposed)
(SCALE 1:100)

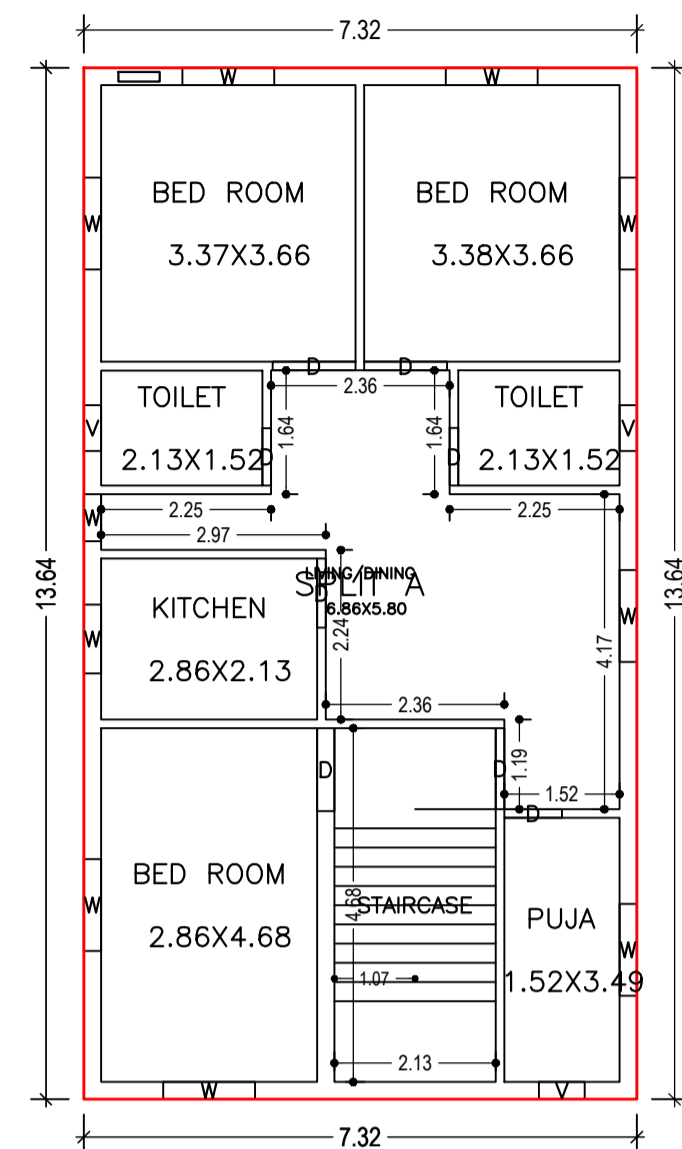

FIRST FLOOR PLAN
(Proposed)
(SCALE 1:100)

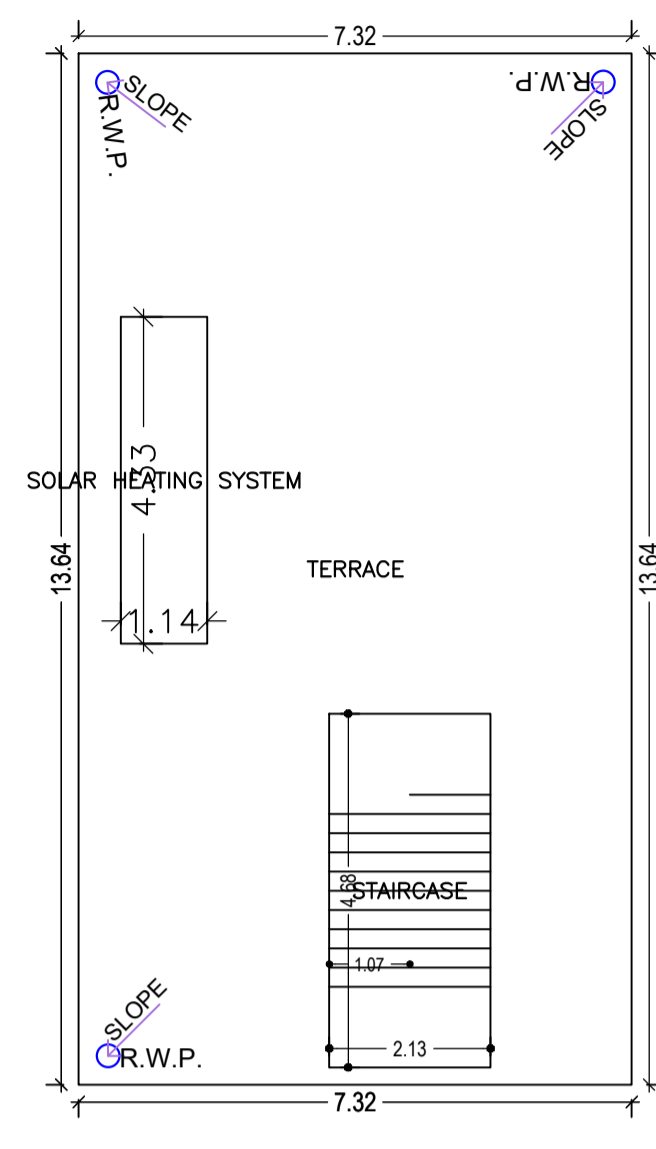

TERRACE FLOOR PLAN
(SCALE 1:100)

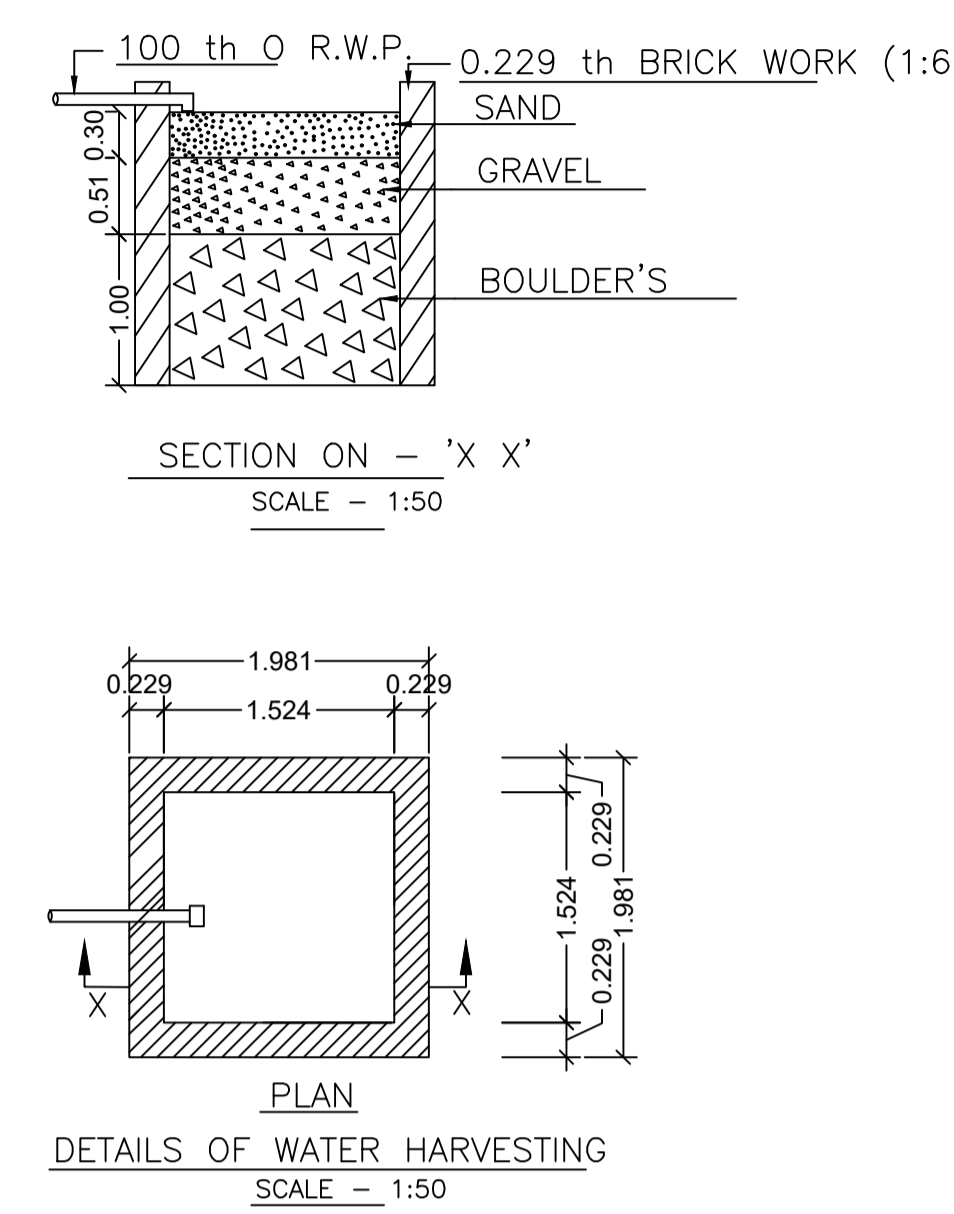

DETAILS OF WATER HARVESTING
SCALE - 1:50

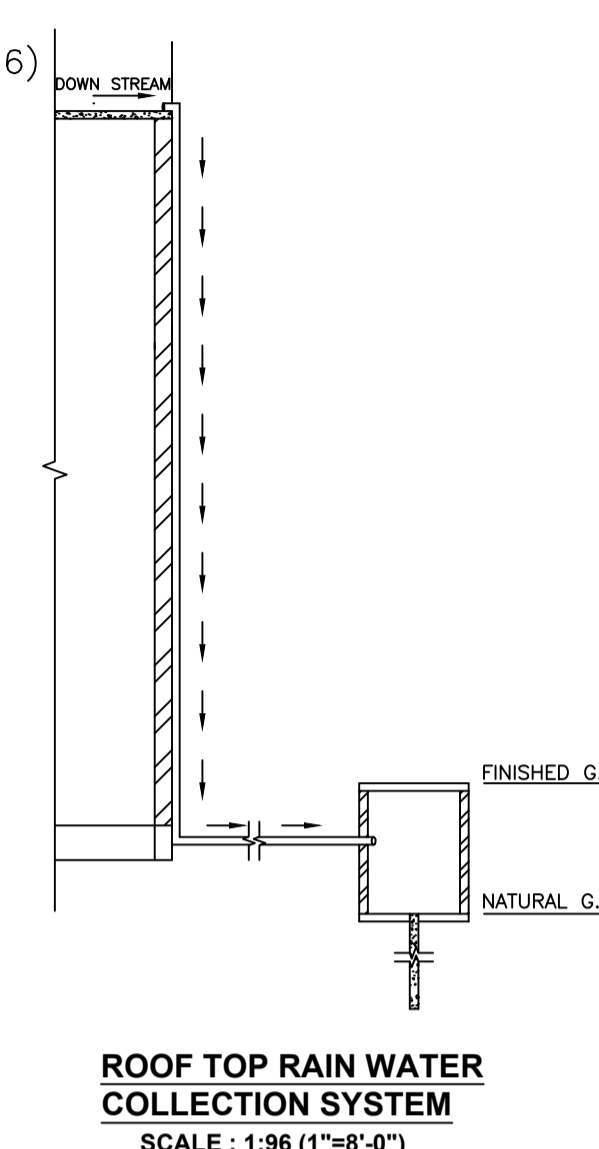

ROOF TOP RAIN WATER
COLLECTION SYSTEM
SCALE : 1:96 (1"=8'-0")

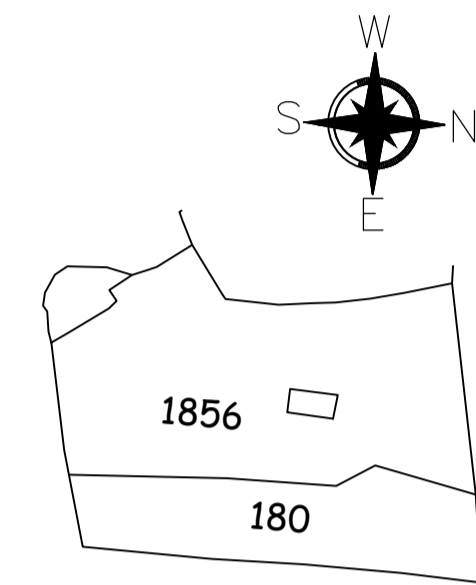

KEY PLAN
SCALE - NTS

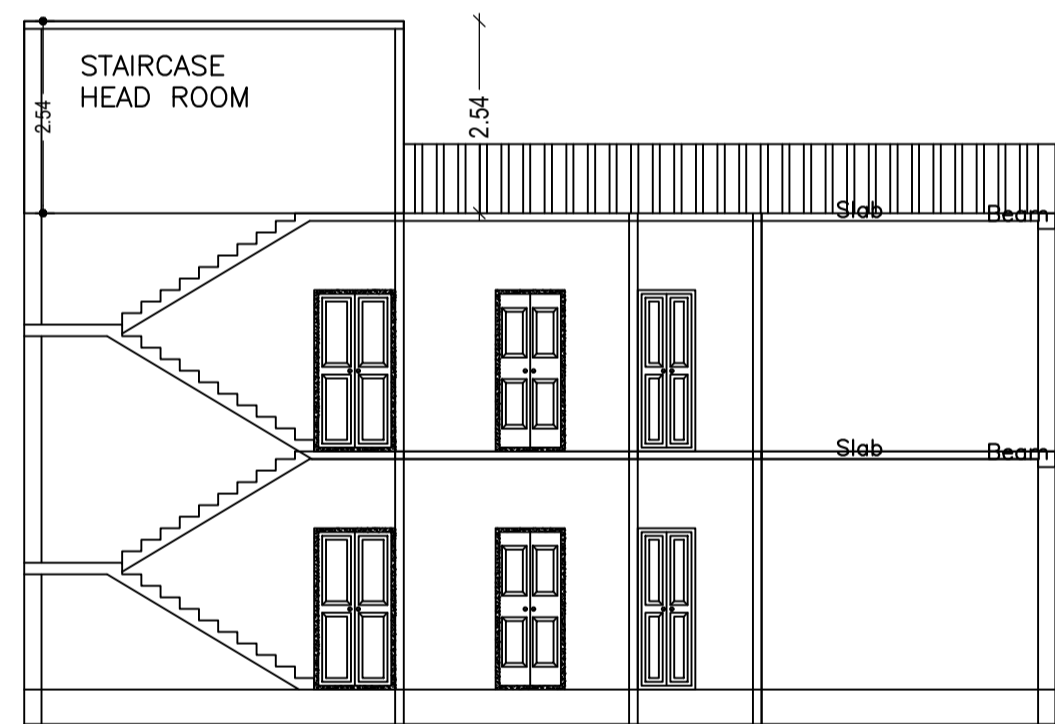

SECTION ON : 'A - A'
SCALE : 1:96 (1"=8'-0")

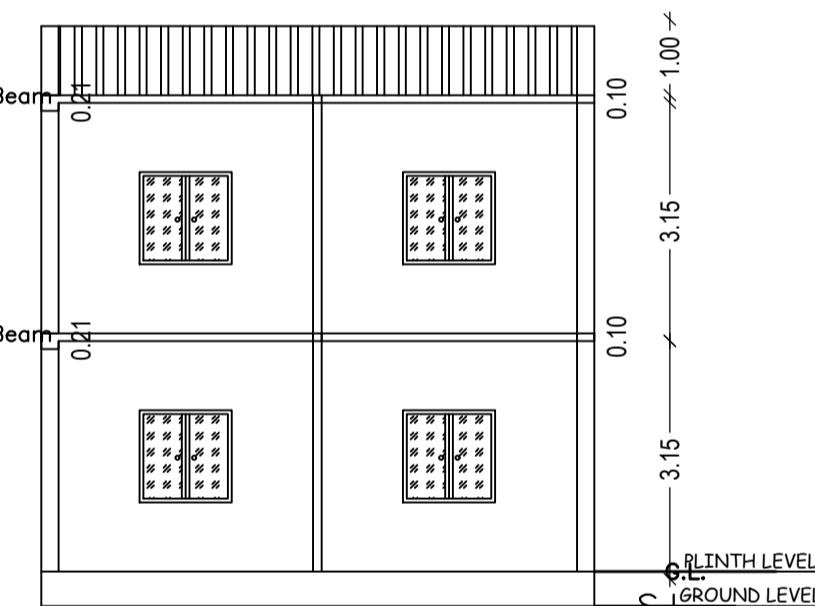

SECTION ON : 'B - B'
SCALE : 1:96 (1"=8'-0")

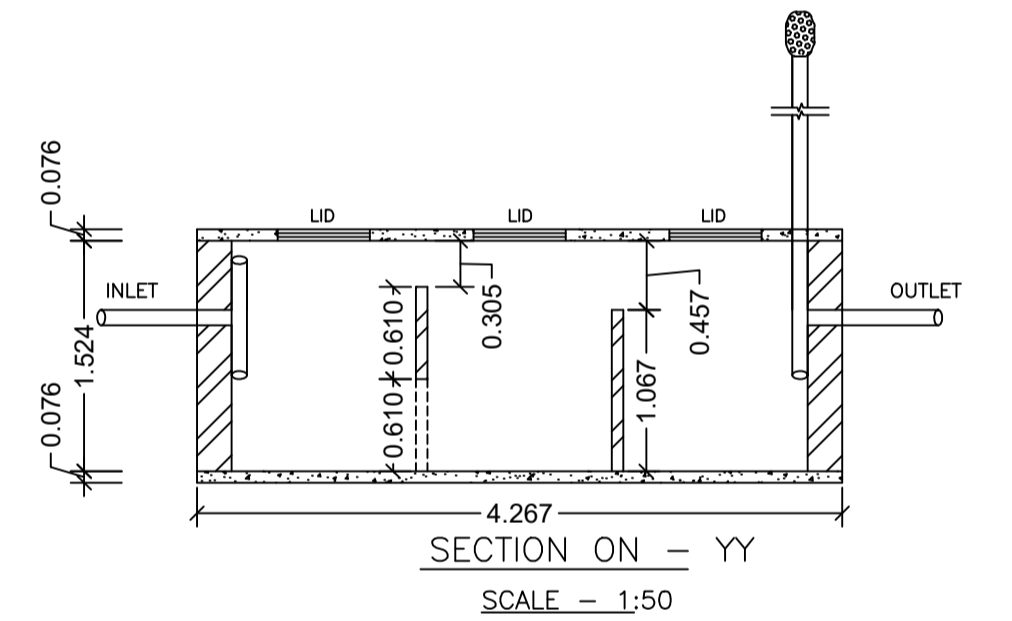

SECTION ON - YY
SCALE - 1:50

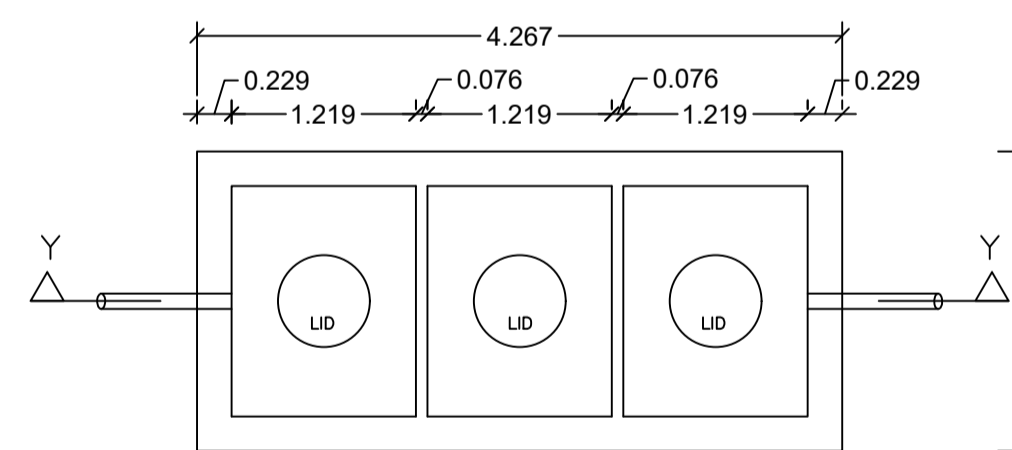

DETAILS OF SEPTIC TANK
SCALE - 1:50

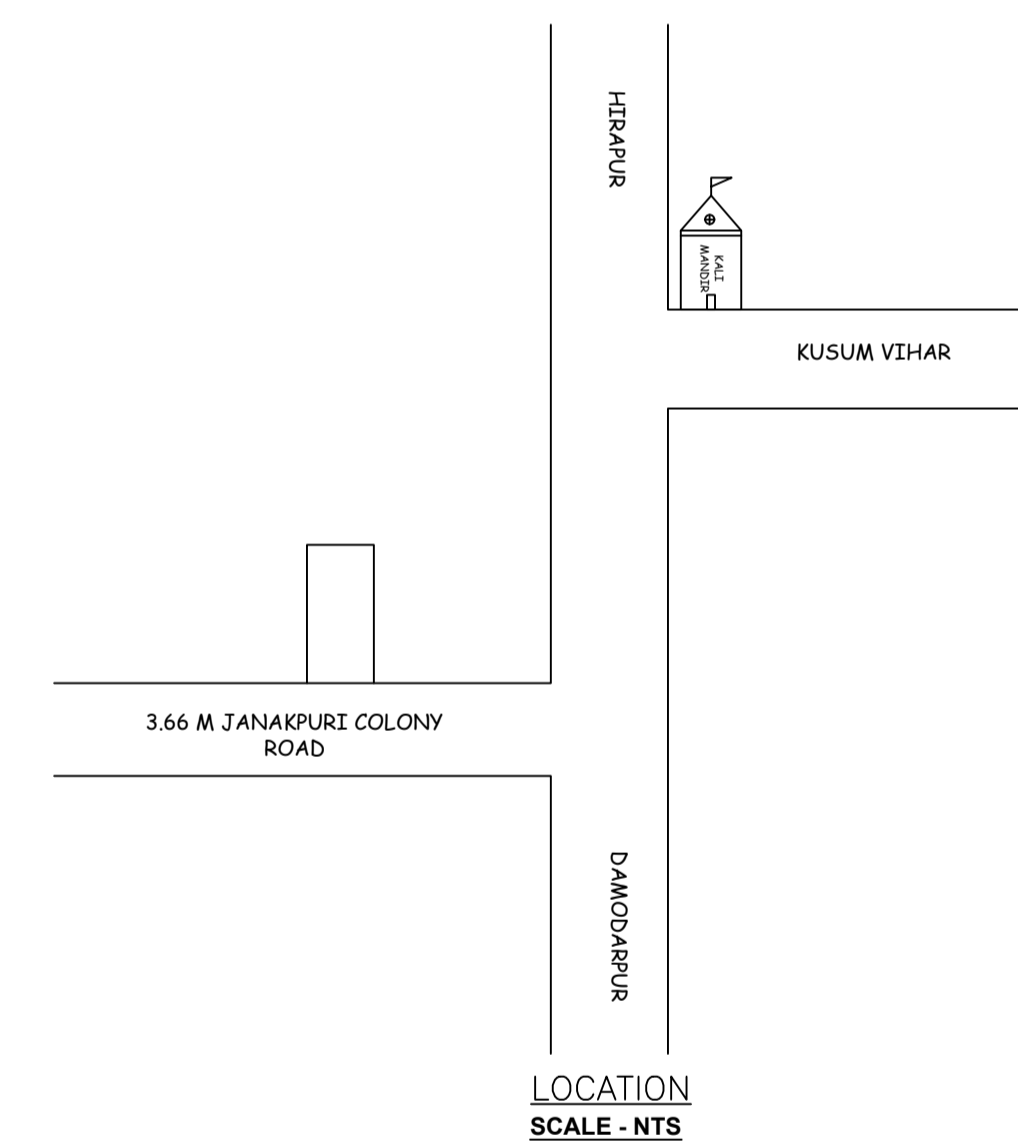

LOCATION
SCALE - NTS

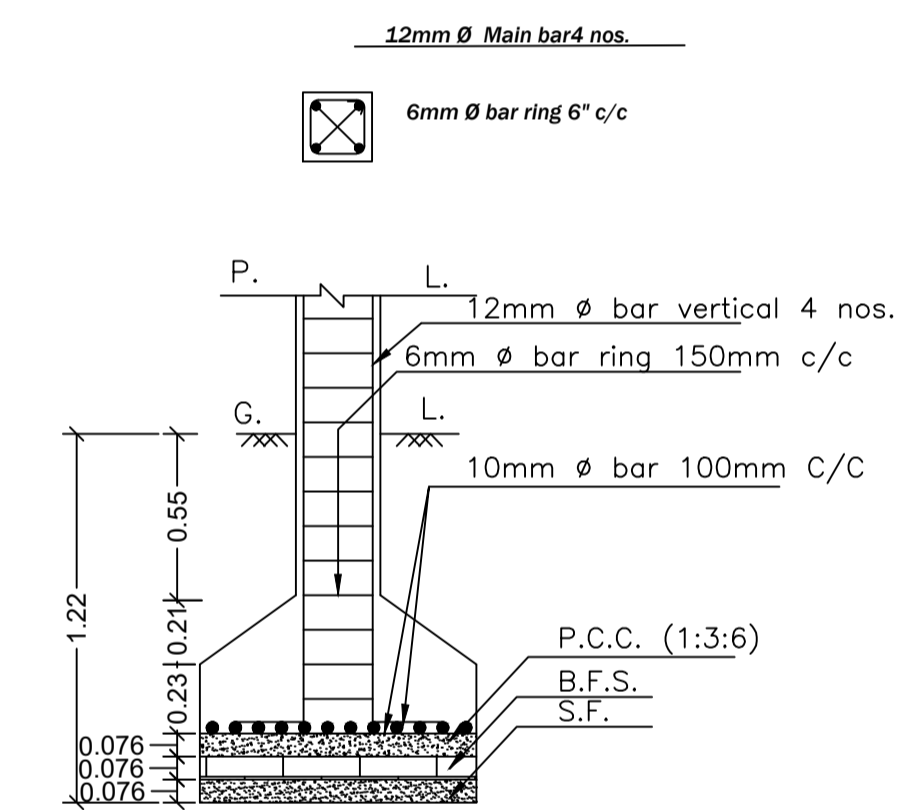

SECTION ON - ZZ
SCALE - 1:25

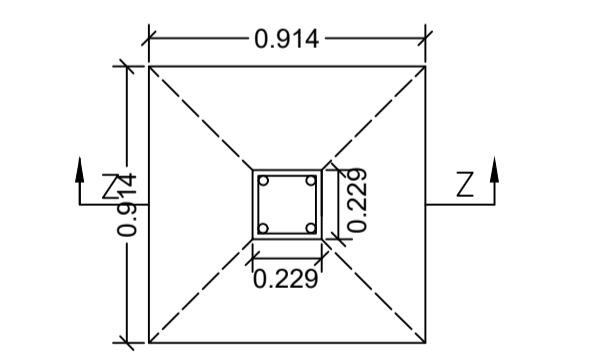

PLAN
DETAILS OF COLUMN FOOTING
SCALE - 1:25

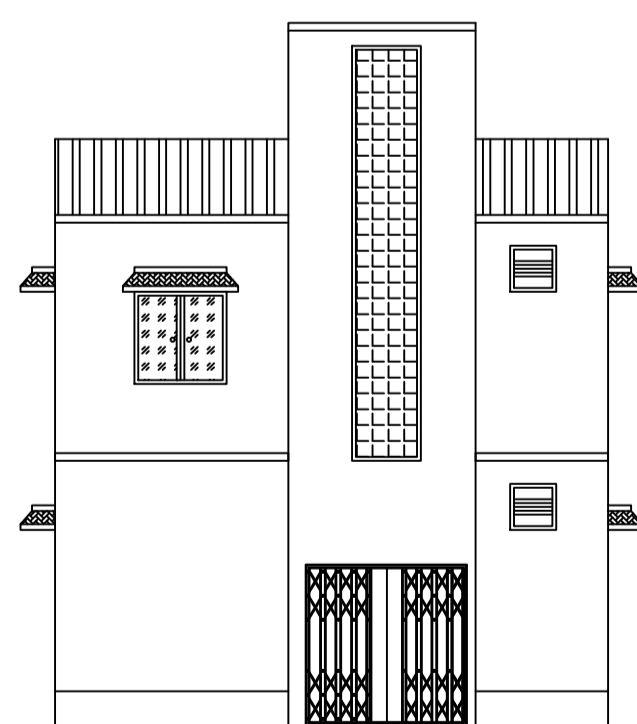

FRONT ELEVATION
SCALE : 1:96 (1"=8'-0")

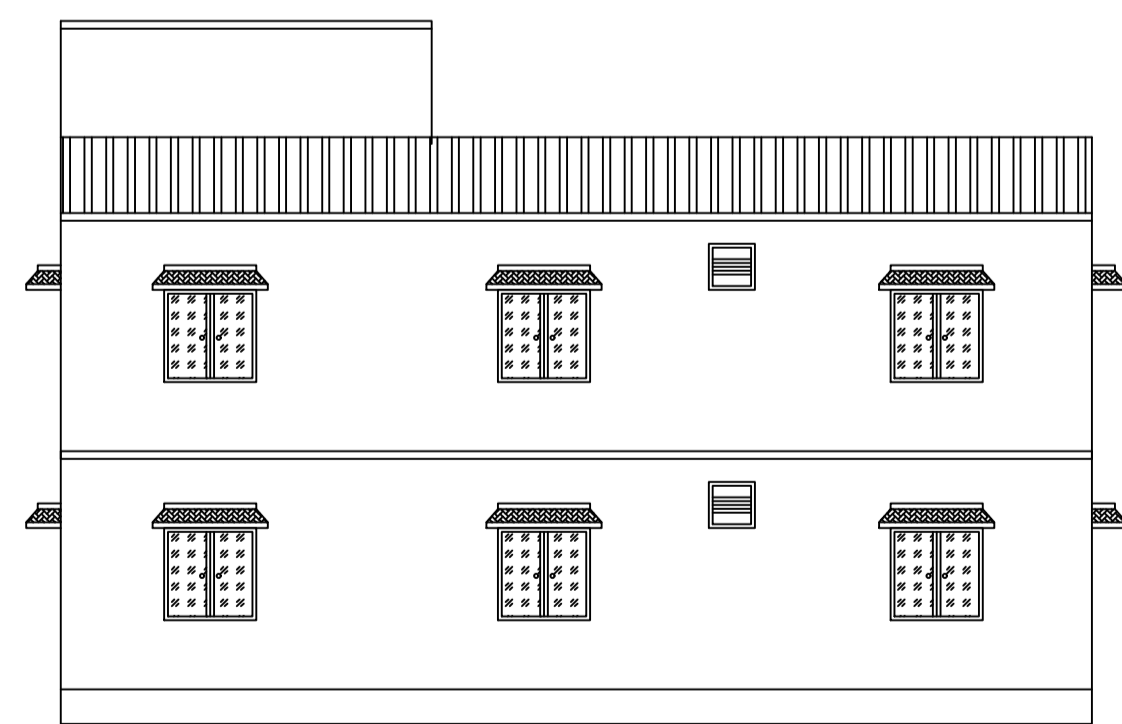

RIGHT SIDE ELEVATION
SCALE : 1:96 (1"=8'-0")

LTP NAME AND SIGNATURE	STRUCTURAL ENG'S NAME AND SIGNATURE	BUILDER NAME AND SIGNATURE	DIGITAL SIGNATURE
SANJEEV KUMAR RAY MADA/ENG/0021/2019			