

Proposal Basic Information	
Proposal File No.	MADA/BP/0008/2021
Owner Name	ARFIN KHATOON
Khata No	OLD-20, NEW-199
Plot No	OLD-1501, NEW-1770
Village Name	Kurmidih
Use	Residential
SubUse	Bungalow/ Dwelling / Non Apartment

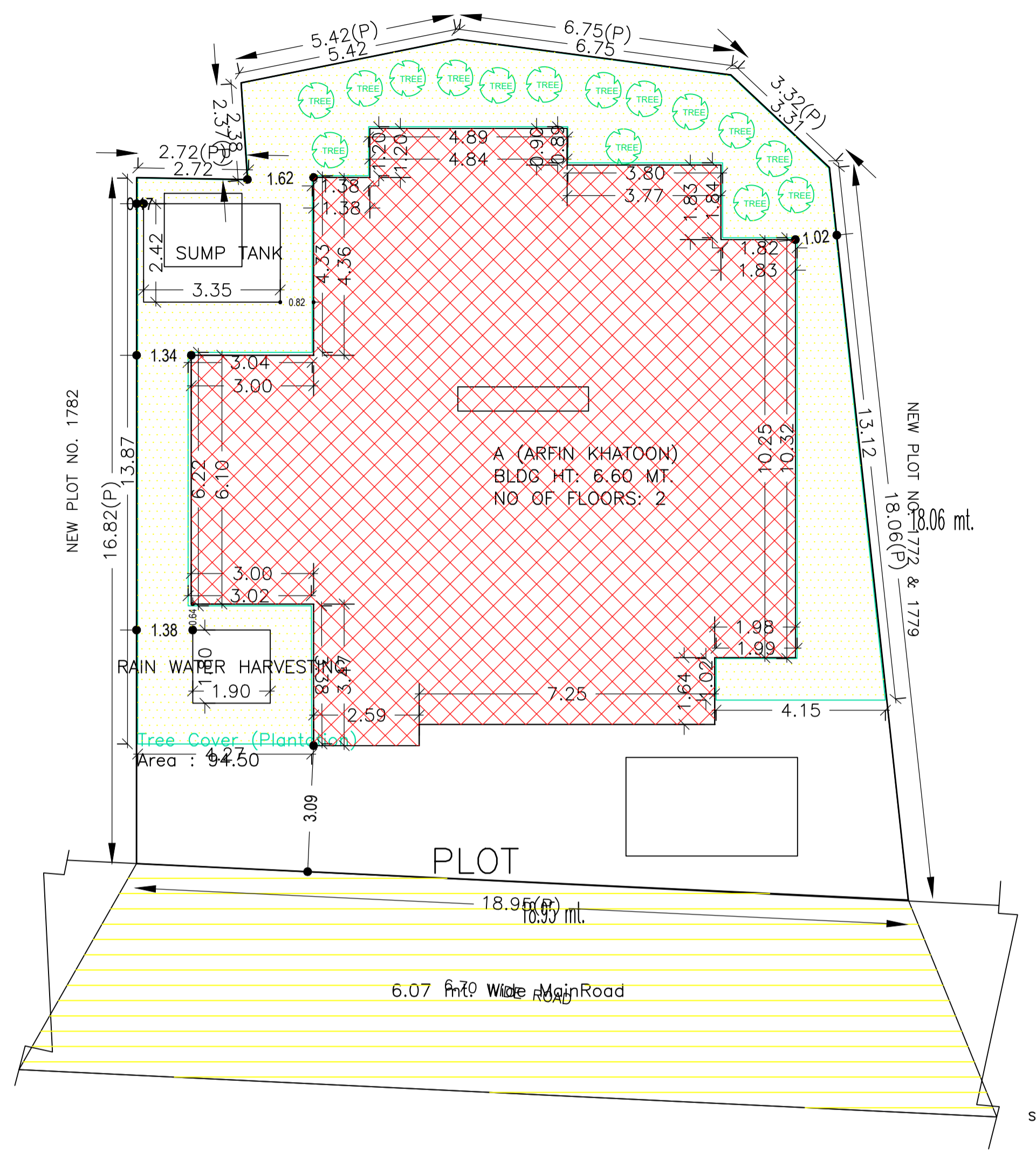

SITE PLAN
SITE PLAN

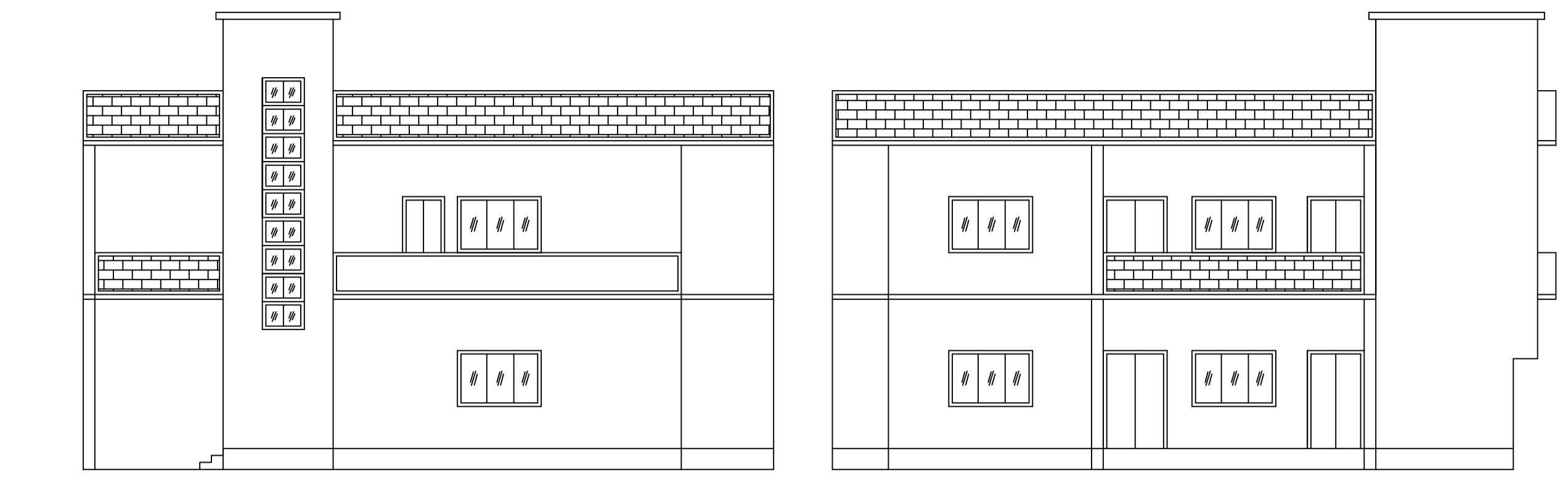

FRONT ELEVATION

LEFT SIDE ELEVATION

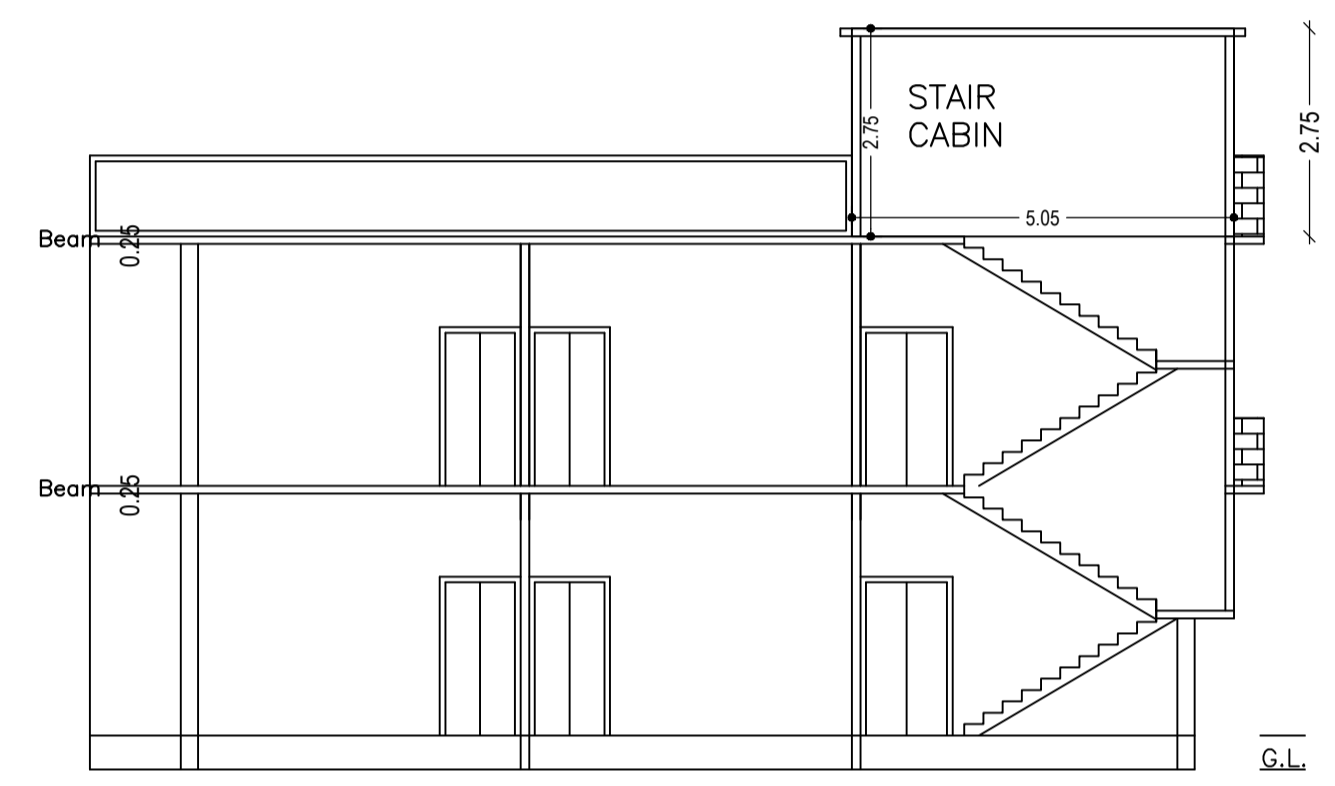

SECTION ON X-X

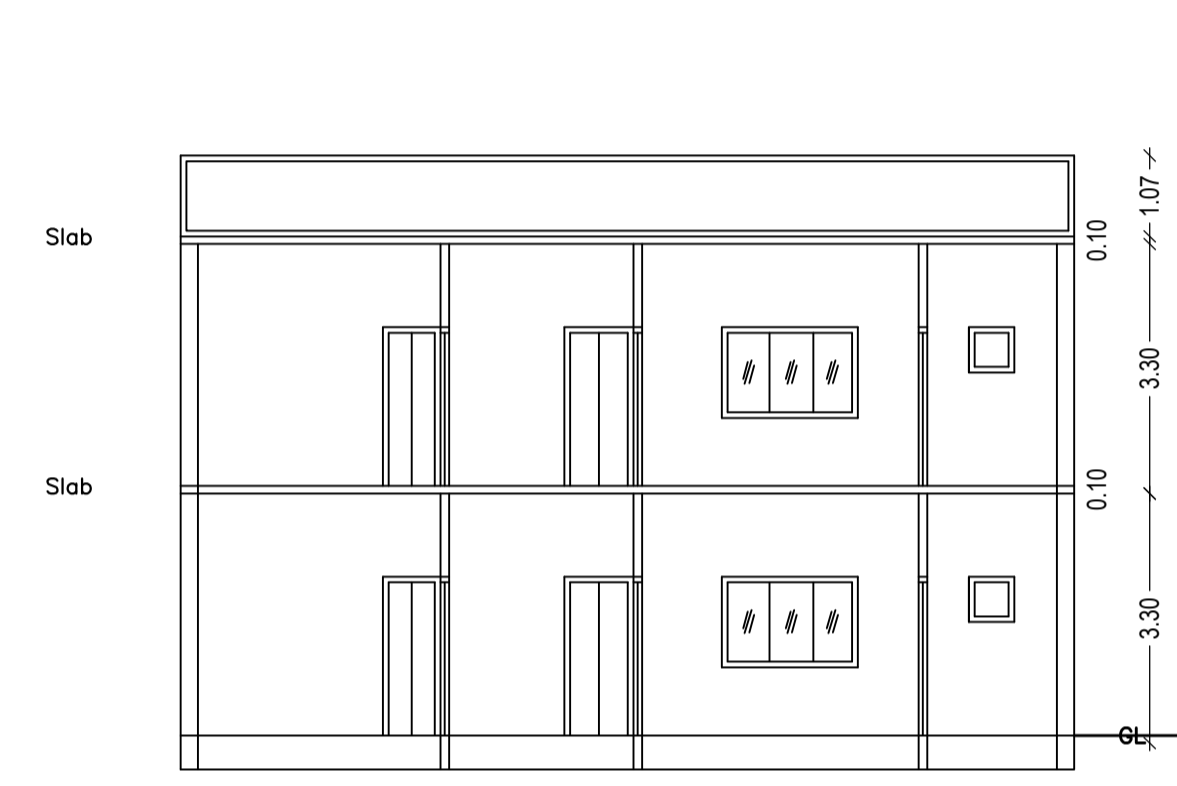

SECTION ON Y-Y

Building :A (ARFIN KHATOON)

Floor Name	Total Built Up Area (Sq.mt.)	Proposed FAR Area (Sq.mt.) Resi.	Total FAR Area (Sq.mt.)	Total Consumed Additional FAR Area (Sq.mt.)	Tnmt (No.)
Ground Floor	179.07	179.07	179.07	179.07	01
First Floor	179.07	179.07	179.07	179.07	00
Terrace Floor	0.00	0.00	0.00	0.00	00
Total :	358.14	358.14	358.14	358.14	01
Total Number of Same Buildings :	1				
Total :	358.14	358.14	358.14	358.14	01

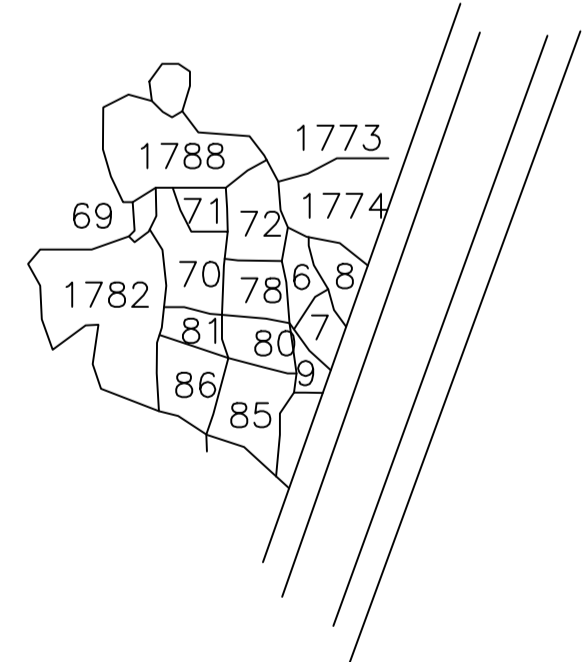

SCHEDULE OF DOOR:

BUILDING NAME	NAME	LENGTH	HEIGHT	NOS
A (ARFIN KHATOON)	d	0.76	2.10	08
A (ARFIN KHATOON)	d	0.91	2.10	06
A (ARFIN KHATOON)	d	1.07	2.10	08
A (ARFIN KHATOON)	d	1.22	2.10	06
A (ARFIN KHATOON)	d	1.37	2.10	02

SCHEDULE OF WINDOW/VENTILATION:

BUILDING NAME	NAME	LENGTH	HEIGHT	NOS
A (ARFIN KHATOON)	W	1.15	1.20	06
A (ARFIN KHATOON)	W	1.31	1.20	02
A (ARFIN KHATOON)	W	1.71	1.20	02
A (ARFIN KHATOON)	W	1.85	1.20	02
A (ARFIN KHATOON)	W	2.06	1.20	02
A (ARFIN KHATOON)	W	2.18	1.20	02
A (ARFIN KHATOON)	W	2.38	1.20	02
A (ARFIN KHATOON)	W	2.44	1.20	02
A (ARFIN KHATOON)	W	2.49	1.20	02
A (ARFIN KHATOON)	W	2.60	1.20	02
A (ARFIN KHATOON)	W	2.68	1.20	02

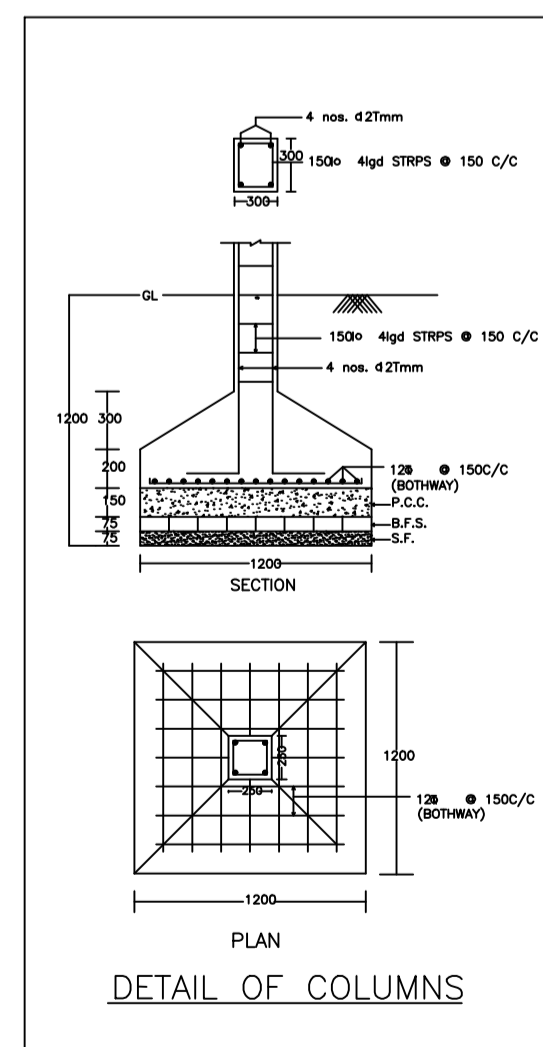

DETAIL OF COLUMNS

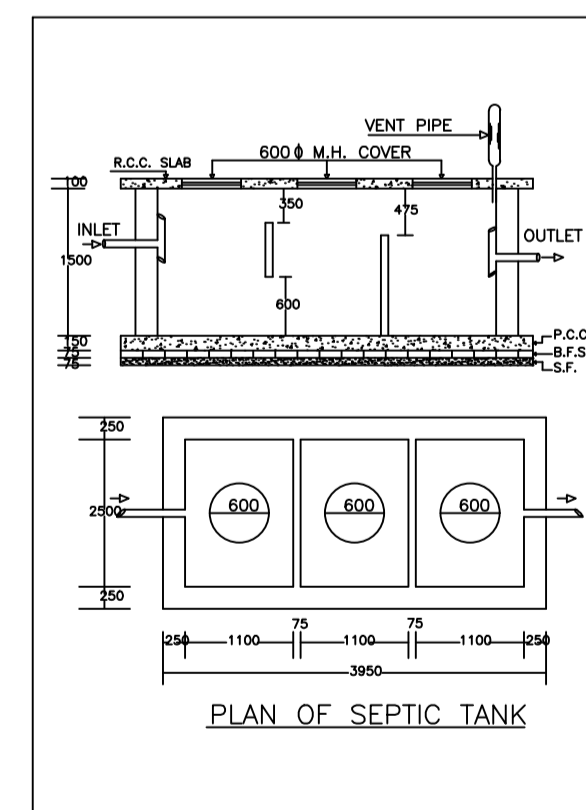

PLAN OF SEPTIC TANK

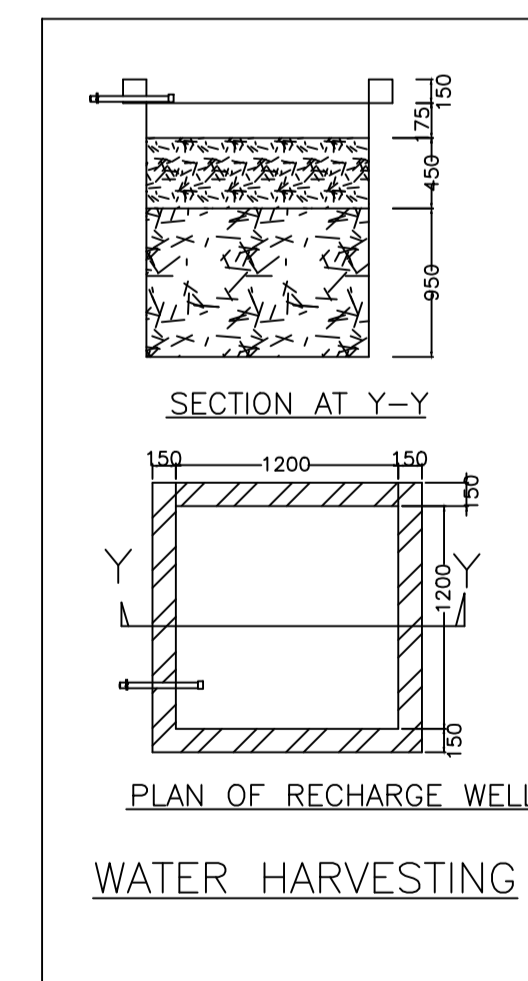

PLAN OF RECHARGE WELL WATER HARVESTING

AREA STATEMENT MINERAL AREA DEVELOPMENT AUTHORITY		VERSION NO. : 1.0.54
PROJECT DETAIL:		VERSION DATE: 16/10/2020
Region: JHARKHAND URBAN LOCAL BODIES	Plot Use: Residential	
District: DHANBAD	Plot SubUse: Bungalow/ Dwelling / Non Apartment	
Authority: MINERAL AREA DEVELOPMENT AUTHORITY	PlotNearby/ReligiousStructure: NA	
Inward No: MADA/BP/0008/2021	Plot/SubPlot No: OLD-1501, NEW-1770	
Application Type: General Proposal	North: Road Width - 6.70	
Project Type: Building Permission	South: Plot No. - 1781	
Nature of Development: New	East: Plot No. - 1772, 1779	
Location of Development Area: Old Area	West: Plot No. - 1782	
AREA DETAILS:		
AREA OF PLOT (Minimum)	(A)	SQ.MT. 348.08
NET AREA OF PLOT(Gross Plot Area - Deduction from Gross Plot area)	(A-Deductions)	348.08
Deduction for Balance Plot Area(from Gross Plot Area)		
Common Plot		94.50
Total		94.50
BALANCE AREA OF PLOT(Net Plot Area - Recreational/Amenity space)	(A-Deductions)	253.58
PLOT AREA FOR COVERAGE(Net Plot Area)	(A-Deductions)	348.08
Plot Area for FAR (Net Plot Area + RoadWidening Area)	(A-Deductions)	348.08
COVERAGE CHECK		
Permissible Coverage area (60.00 %)		208.85
Proposed Coverage Area (51.45 %)		179.07
Total Prop. Coverage Area (51.45 %)		179.07
Balance coverage area (8.56 %)		29.78
FAR CHECK		
Perm. FAR Area (1.80)		626.54
Total Perm. FAR area		626.54
Residential FAR		358.14
Proposed FAR Area		358.14
Total Proposed FAR Area		358.14
Consumed FAR (Factor)		1.03
Balance FAR Area		268.40
BUILT UP AREA CHECK		
Total Proposed BuiltUp Area		358.14
ARCHITECT (Regd)		RAJEEV RANJAN SINGH
ENGINEER (Regd)		
SUPERVISOR (Regd)		
OWNER (Regd)		ARFIN KHATOON
DEVELOPMENT AUTHORITY		LOCAL BODY

COLOR INDEX	
PLOT BOUNDARY	Black
ABUTTING ROAD	Green
PROPOSED CONSTRUCTION	Red
COMMON PLOT	Yellow
ROAD WIDENING AREA	Blue
EXISTING (To be retained)	Light Blue
EXISTING (To be demolished)	Dark Blue

Buildingwise Floor FAR Details

Floor Name	Building Name A (ARFIN KHATOON)		Total	
	Proposed Built Up Area (Sq.mt.)	Proposed FAR Area (Sq.mt.)	Total Proposed Built Up Area (Sq.mt.)	Total FAR Area (Sq.mt.)
Ground Floor	179.07	179.07	179.07	179.07
First Floor	179.07	179.07	179.07	179.07
Terrace Floor	0.00	0.00	0.00	0.00
Total :	358.14	358.14	358.14	358.14

Building USE/SUBUSE Details

Building Name	Building Use	Building SubUse	Building Structure
A (ARFIN KHATOON)	Residential	Residential Bldg/Apartment	Non-Highrise

FAR & Tenement Details (Table 4c-1)

Building	No. of Same Bldg	Total Built Up Area (Sq.mt.)	Proposed FAR Area (Sq.mt.) Resi.	Total FAR Area (Sq.mt.)	Total Consumed Additional FAR Area (Sq.mt.)	Tnmt (No.)
A (ARFIN KHATOON)	1	358.14	358.14	358.14	358.14	01
Grand Total :	1	358.14	358.14	358.14	358.14	01

UnitBUA Table for Building :A (ARFIN KHATOON)

FLOOR	Name	UnitBUA Type	UnitBUA Area	Carpet Area	No. of Rooms	No. of Tenement
GROUND FLOOR PLAN	SPLIT A	FLAT	358.14	357.98	14	1
FIRST FLOOR PLAN	SPLIT A	FLAT	0.00	0.00	14	0
Total:	-	-	358.14	357.98	28	1

LTP NAME AND SIGNATURE	STRUCTURAL ENG'S NAME AND SIGNATURE	BUILDER NAME AND SIGNATURE	DIGITAL SIGNATURE
RAJEEV RANJAN SINGH MADA/ENG/0004/2019			

Proposal Basic Information

Proposal File No.	MADA/BP/0008/2021
Owner Name	ARFIN KHATOON
Khata No	OLD-20, NEW-199
Plot No	OLD-1501, NEW-1770
Village Name	Kurmidih
Use	Residential
SubUse	Bungalow/ Dwelling / Non Apartment

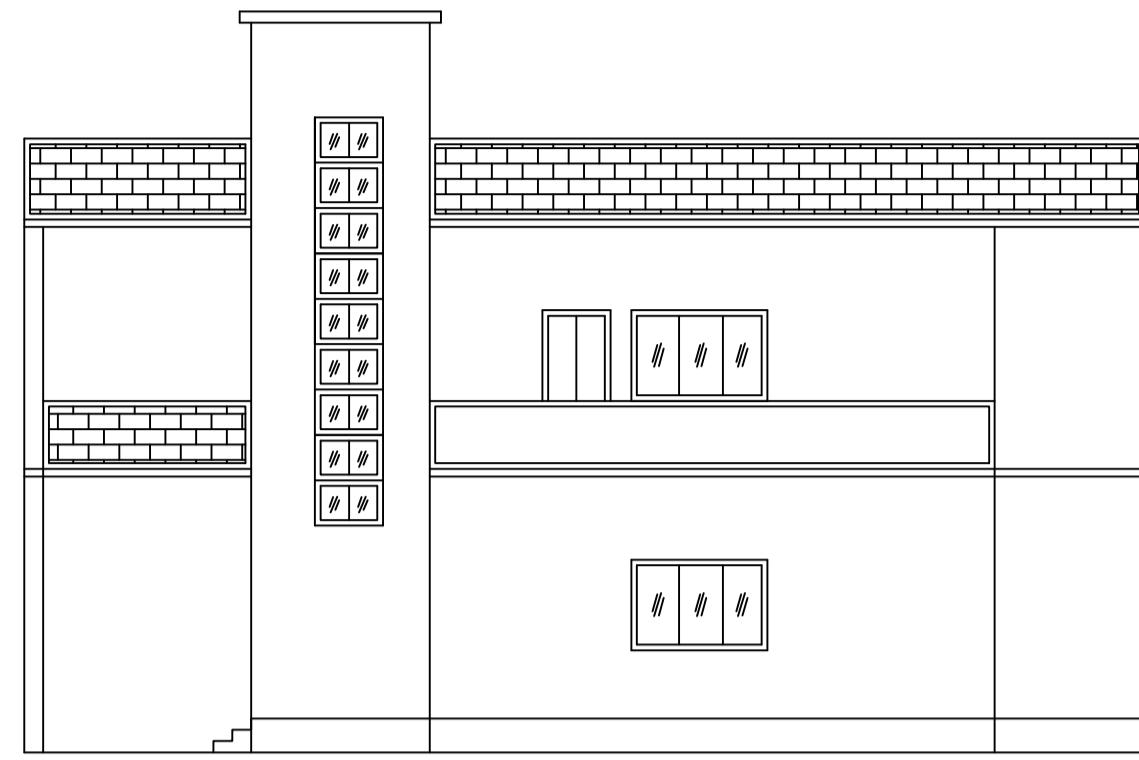

FRONT ELEVATION

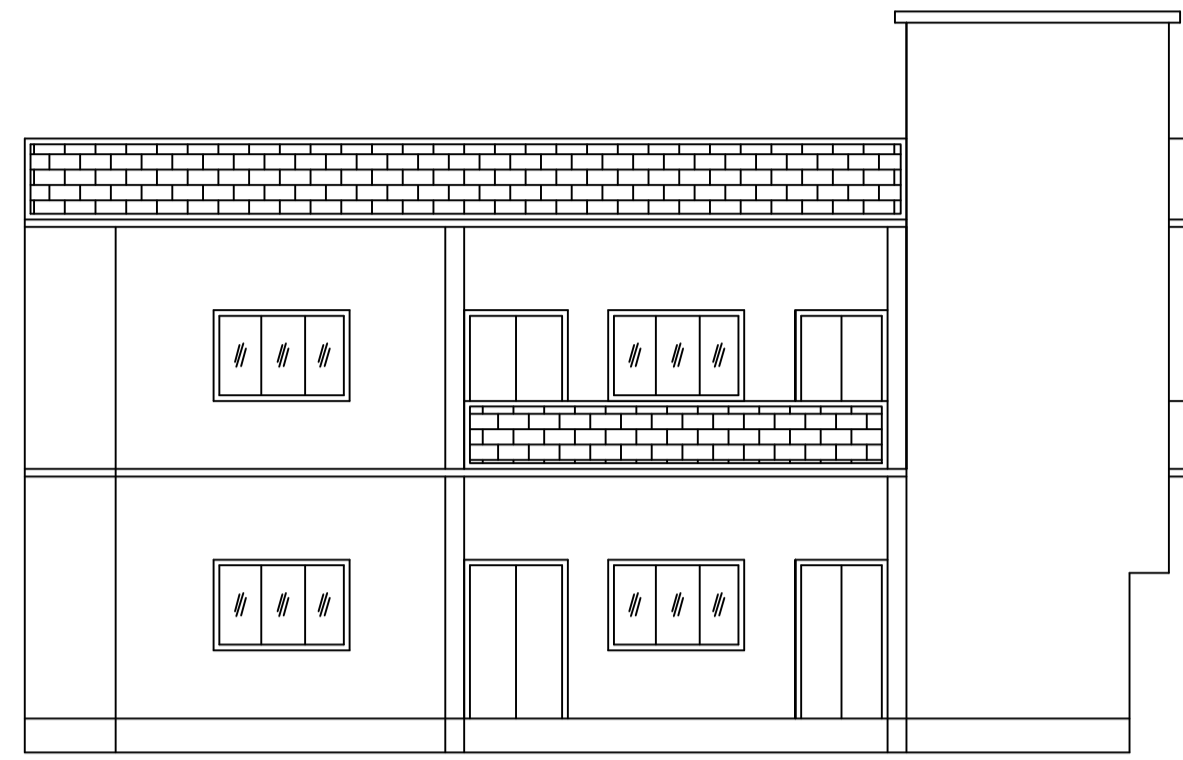

LEFT SIDE ELEVATION

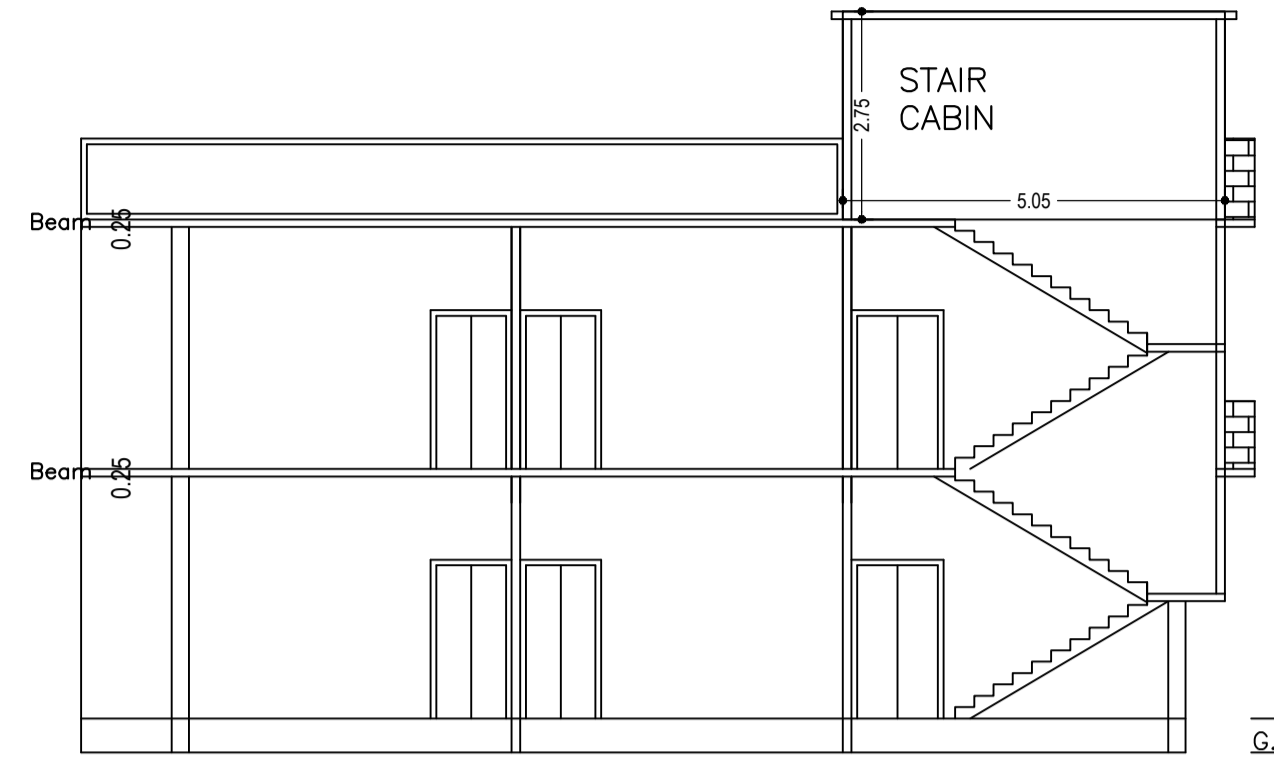

SECTION ON X-X

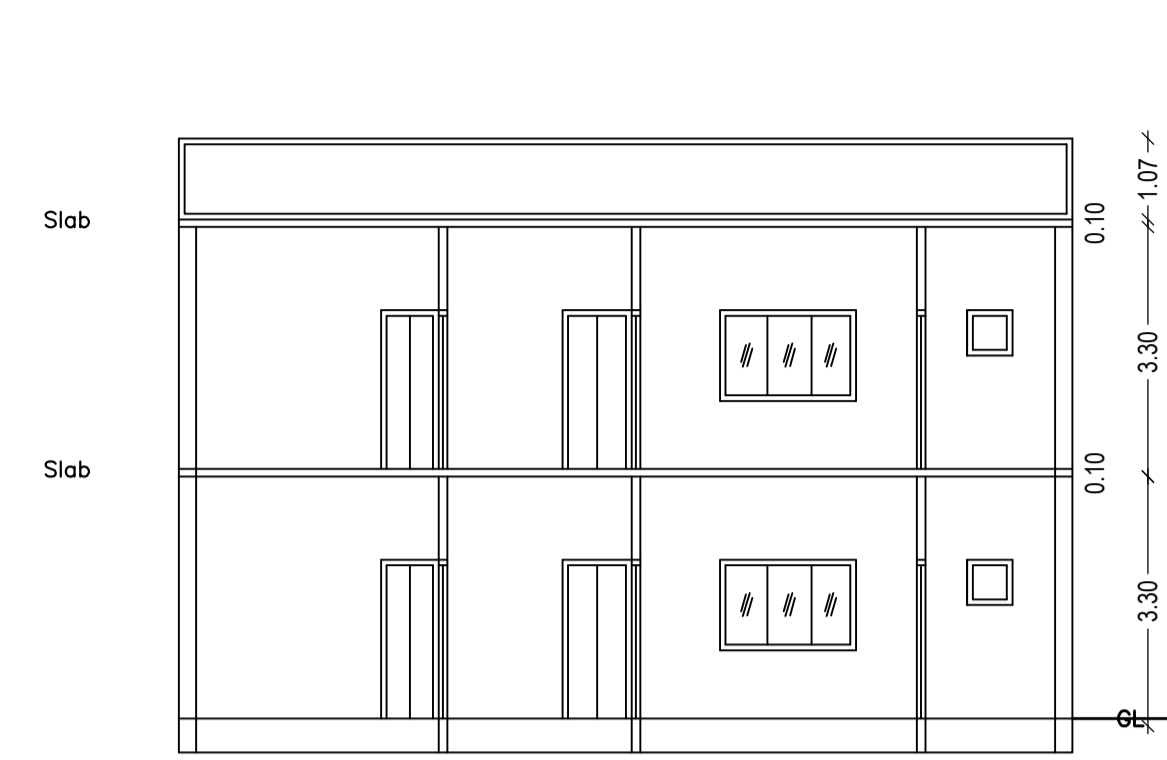

SECTION ON Y-Y

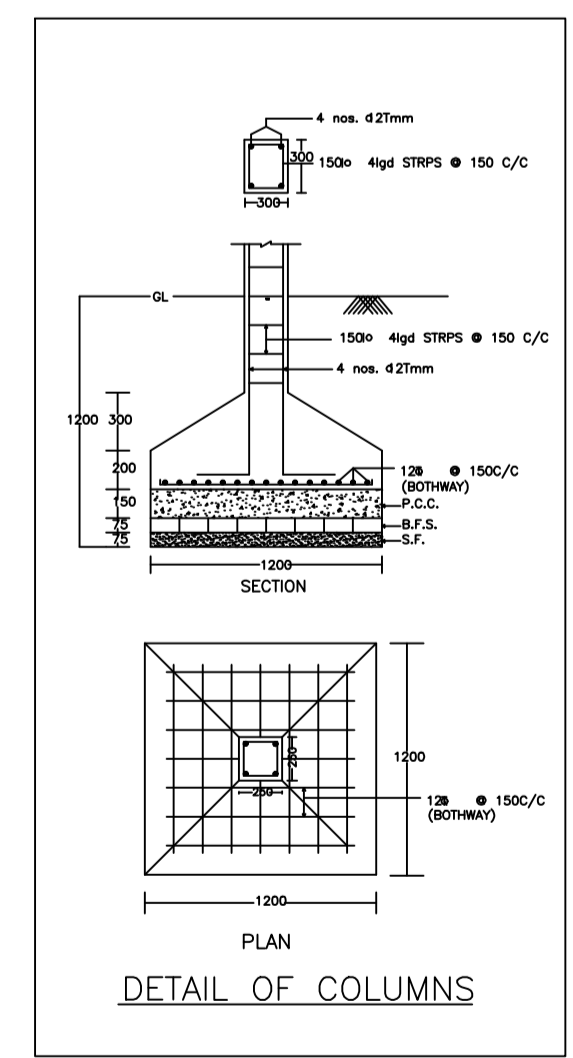
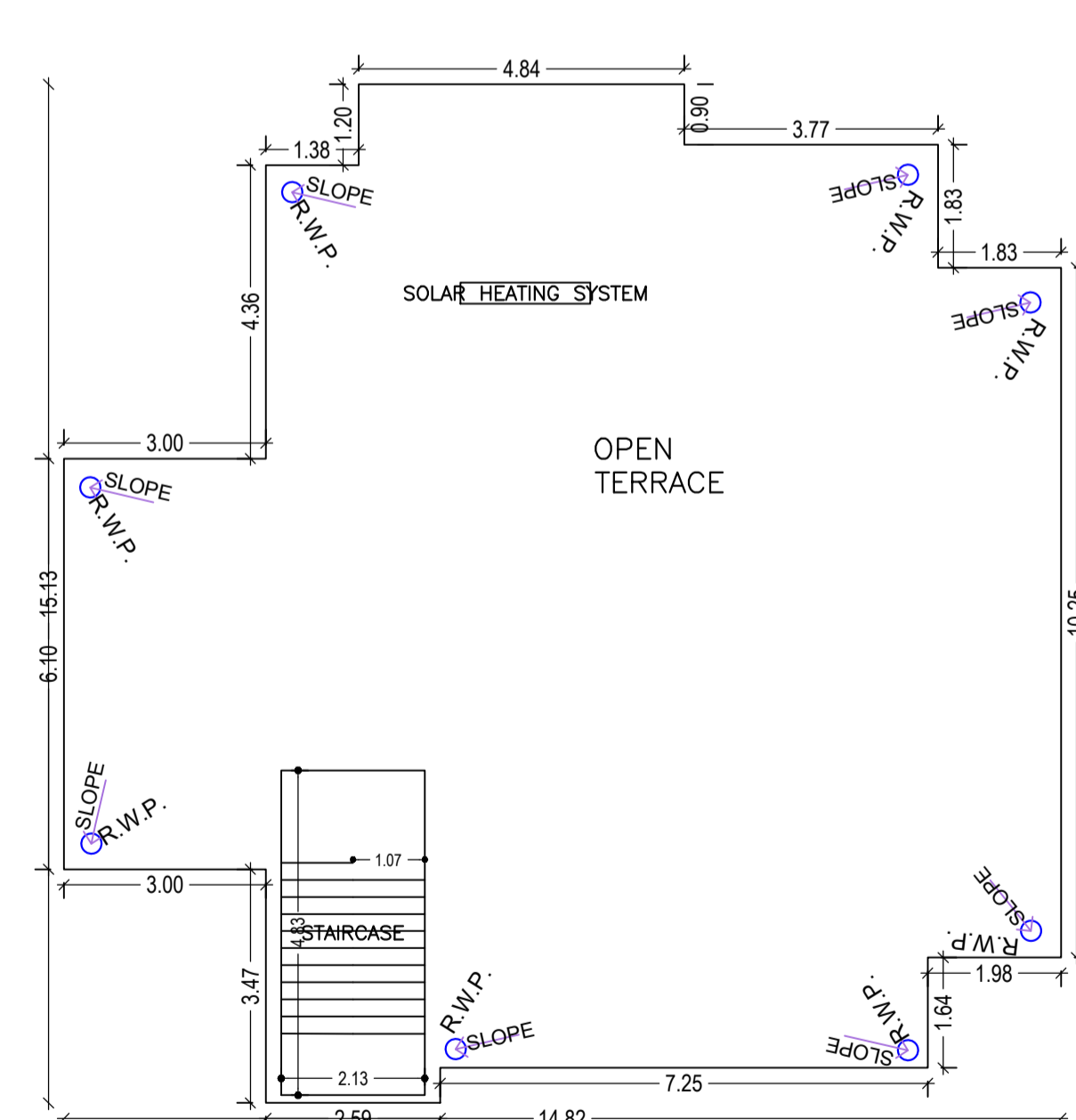
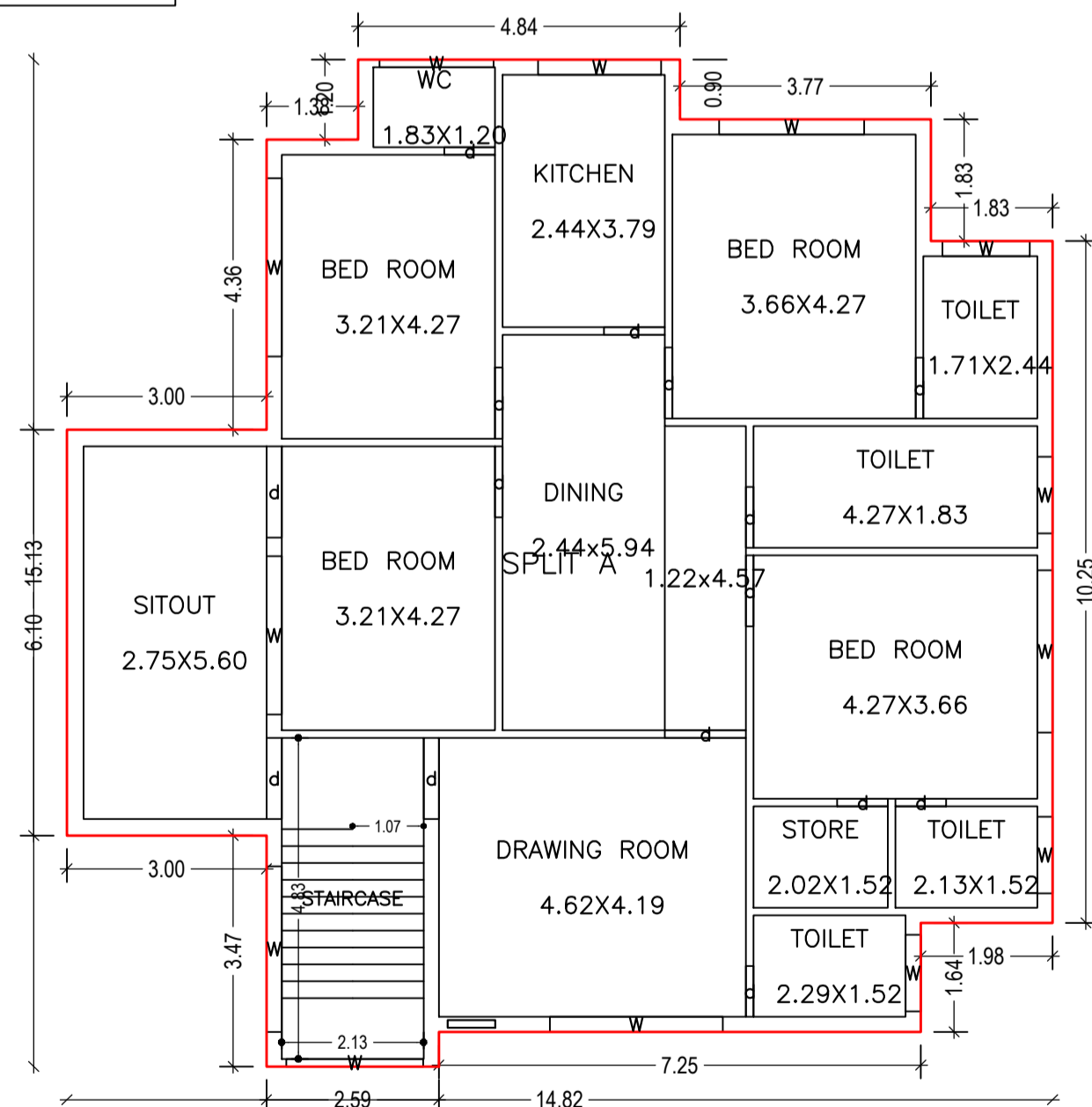
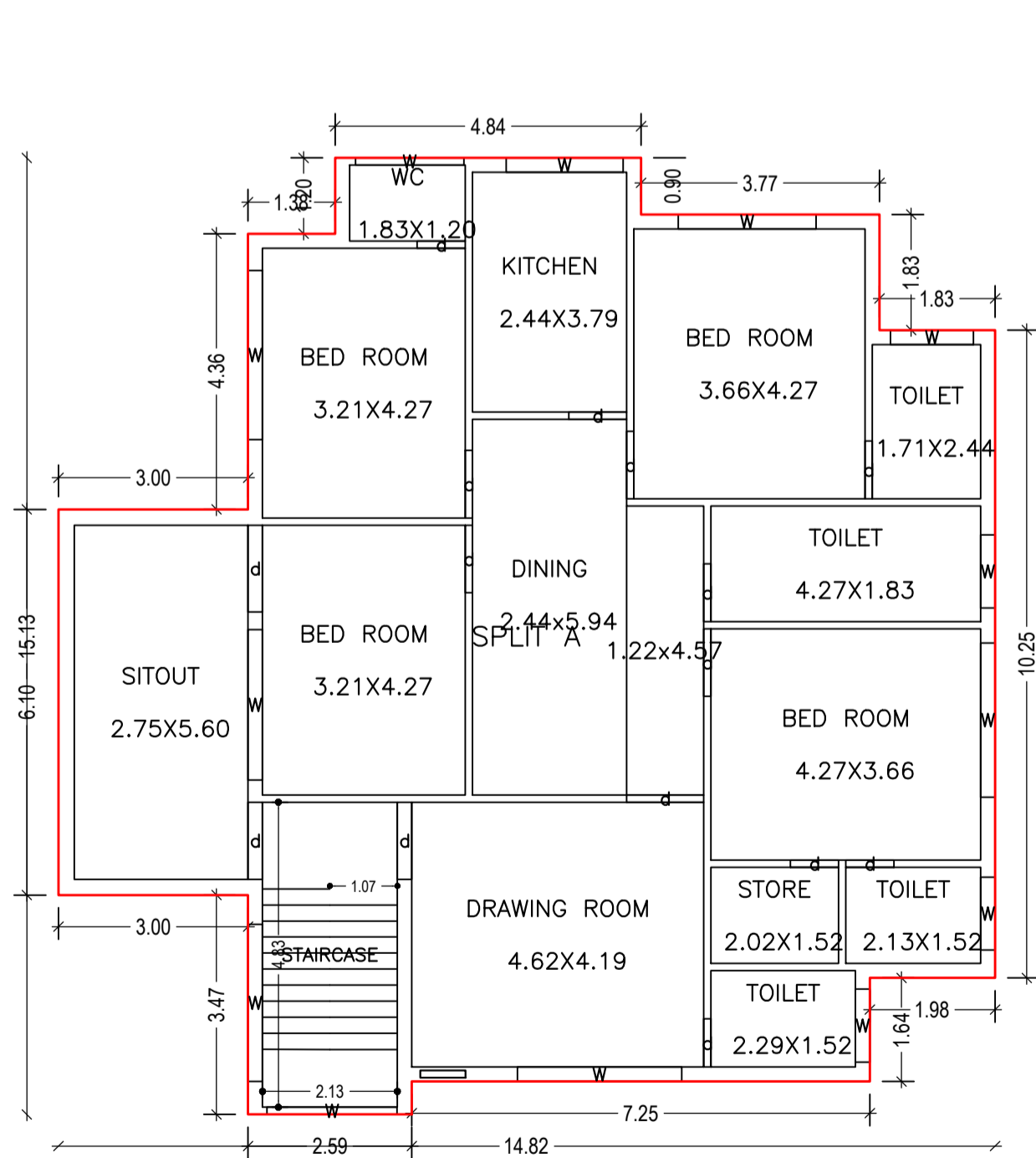
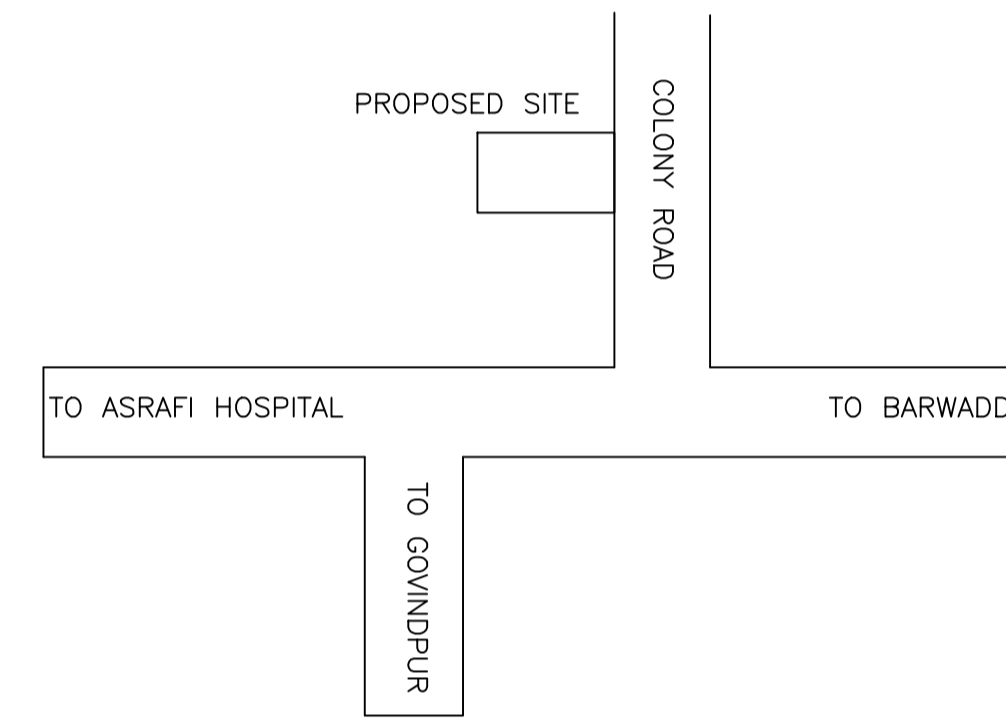
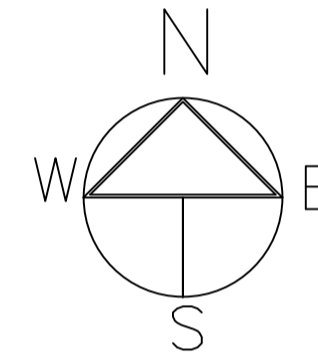
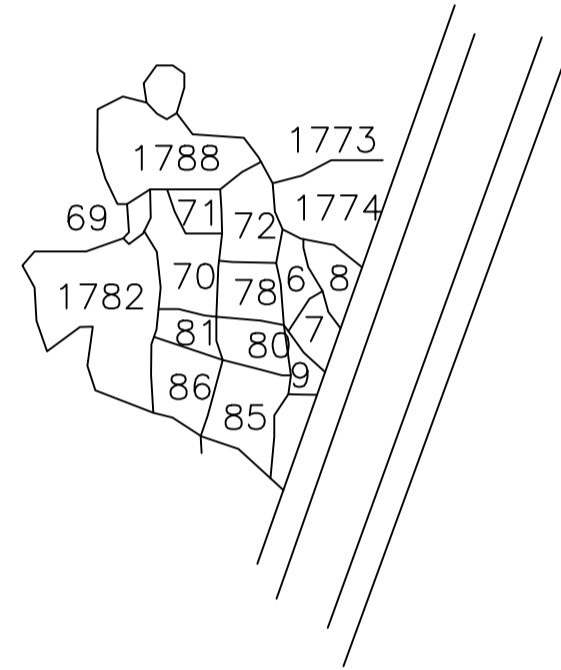
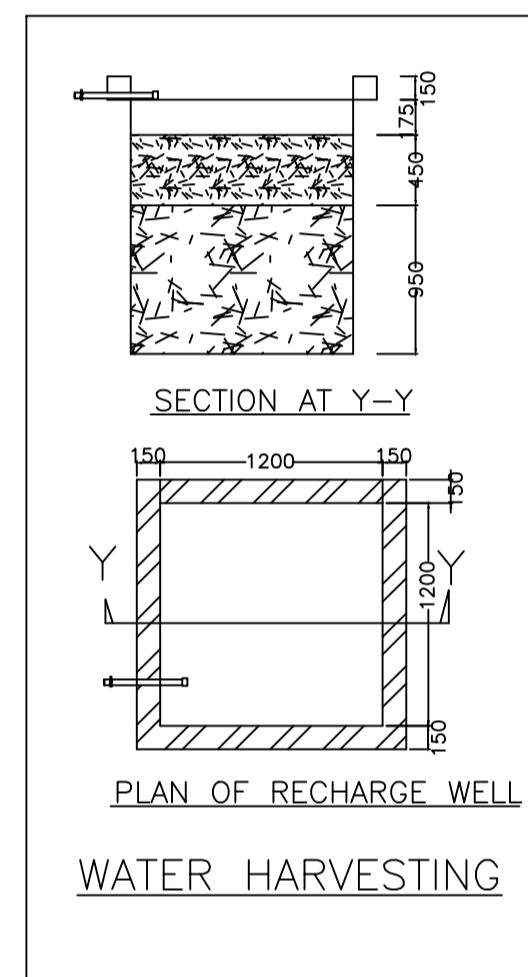
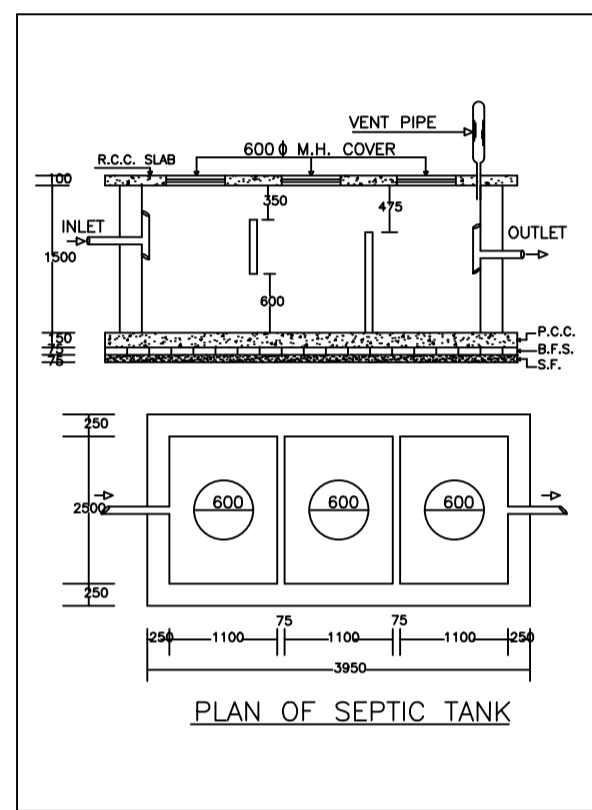

LTP NAME AND SIGNATURE	STRUCTURAL ENG'S NAME AND SIGNATURE	BUILDER NAME AND SIGNATURE	DIGITAL SIGNATURE
RAJEEV RANJAN SINGH MADA/ENG/0004/2019			