

Proposal Basic Information

Proposal File No.	MADA/BP/0172/2021
Owner Name	SRI. TEJ NARAYAN SHARMA
Khata No	OLD KHATA NO-43, NEW KHATA NO-350
Plot No	OLD PLOT NO. 2526, NEW PLOT NO. 4003
Village Name	Bara Pichri
Use	Residential
SubUse	Bungalow/ Dwelling / Non Apartment

AREA STATEMENT MINERAL AREA DEVELOPMENT AUTHORITY	VERSION NO.: 1.0.59	
	VERSION DATE: 16/10/2020	
PROJECT DETAIL:		
Region: JHARKHAND URBAN LOCAL BODIES	Plot Use: Residential	
District: DHANBAD	Plot SubUse: Bungalow/ Dwelling / Non Apartment	
Authority: MINERAL AREA DEVELOPMENT AUTHORITY	PlotNearby/ReligiousStructure: NA	
Inward No: MADA/BP/0172/2021	Plot/SubPlot No: OLD PLOT NO. 2526, NEW PLOT NO. 4003	
Application Type: General Proposal	North: Plot No. - SAME PLOT	
Project Type: Building Permission	South: Plot No. - SAME PLOT	
Nature of Development: New	East: Road Width - 6.1	
Location of Development Area: Old Area	West: Plot No. - SAME PLOT	
AREA DETAILS:		
AREA OF PLOT (Minimum)	(A)	SQ.MT. 138.85
NET AREA OF PLOT (Gross Plot Area - Deduction from Gross Plot area)	(A-Deductions)	138.85
Deduction for Balance Plot Area (from Gross Plot Area)		
Common Plot		14.63
Total		14.63
BALANCE AREA OF PLOT (Net Plot Area - Recreational/Amenity spaces)	(A-Deductions)	124.22
PLOT AREA FOR COVERAGE (Net Plot Area)	(A-Deductions)	138.85
Plot Area for FAR (Net Plot Area + Road/Widening Area)	(A-Deductions)	138.85
COVERAGE CHECK		
Permissible Coverage area (70.00 %)		97.19
Proposed Coverage Area (58.83 %)		81.68
Total Prop. Coverage Area (58.83 %)		81.68
Balance coverage area (11.17 %)		15.51
FAR CHECK		
Perm. FAR Area (2.50)		347.13
Total Perm. FAR area		347.13
Residential FAR		163.36
Proposed FAR Area		163.36
Total Proposed FAR Area		163.36
Consumed FAR (Factor)		1.18
Balance FAR Area		183.77
BUILT UP AREA CHECK		
Total Proposed BuiltUp Area		164.52
ARCHITECT (Regd)		RAM PRATAP SINGH
ENGINEER (Regd)		
SUPERVISOR (Regd)		
OWNER (Regd)		SRI. TEJ NARAYAN SHARMA
DEVELOPMENT AUTHORITY		LOCAL BODY

COLOR INDEX

PLOT BOUNDARY	Black
ABUTTING ROAD	Green
PROPOSED CONSTRUCTION	Red
COMMON PLOT	Yellow
ROAD WIDENING AREA	Orange
EXISTING (To be retained)	Blue
EXISTING (To be demolished)	Light Blue

SCHEDULE OF DOOR:

BUILDING NAME	NAME	LENGTH	HEIGHT	NOS
A (TEJ NARAYAN)	D	0.76	2.10	02
A (TEJ NARAYAN)	D	0.90	2.10	06
A (TEJ NARAYAN)	D	0.91	2.10	03
A (TEJ NARAYAN)	D	1.03	2.10	02
A (TEJ NARAYAN)	D	1.22	2.10	01

SCHEDULE OF WINDOW/VENTILATION:

BUILDING NAME	NAME	LENGTH	HEIGHT	NOS
A (TEJ NARAYAN)	W	0.61	1.20	02
A (TEJ NARAYAN)	W	0.91	1.20	04
A (TEJ NARAYAN)	W	1.22	1.20	12
A (TEJ NARAYAN)	W	1.80	1.20	02
A (TEJ NARAYAN)	W	1.82	1.20	01
A (TEJ NARAYAN)	W	2.43	1.20	01

UnitBUA Table for Building :A (TEJ NARAYAN)

FLOOR	Name	UnitBUA Type	UnitBUA Area	Carpet Area	No. of Rooms	No. of Tenement
GROUND FLOOR PLAN	SPLIT 1	FLAT	163.36	161.44	6	1
FIRST FLOOR PLAN	SPLIT 1	FLAT	0.00	0.00	7	0
Total:	-	-	163.36	161.44	13	1

FAR & Tenement Details (Table 4c-1)

Building	No. of Same Bldg	Total Built Up Area (Sq.mt.)	Deductions (Area in Sq.mt.) StairCase	Proposed FAR Area (Sq.mt.) Resi.	Total FAR Area (Sq.mt.)	Total Consumed Additional FAR Area (Sq.mt.)	Trmt (No.)
A (TEJ NARAYAN)	1	164.52	1.16	163.36	163.36	163.36	01
Grand Total:	1	164.52	1.16	163.36	163.36	163.36	01

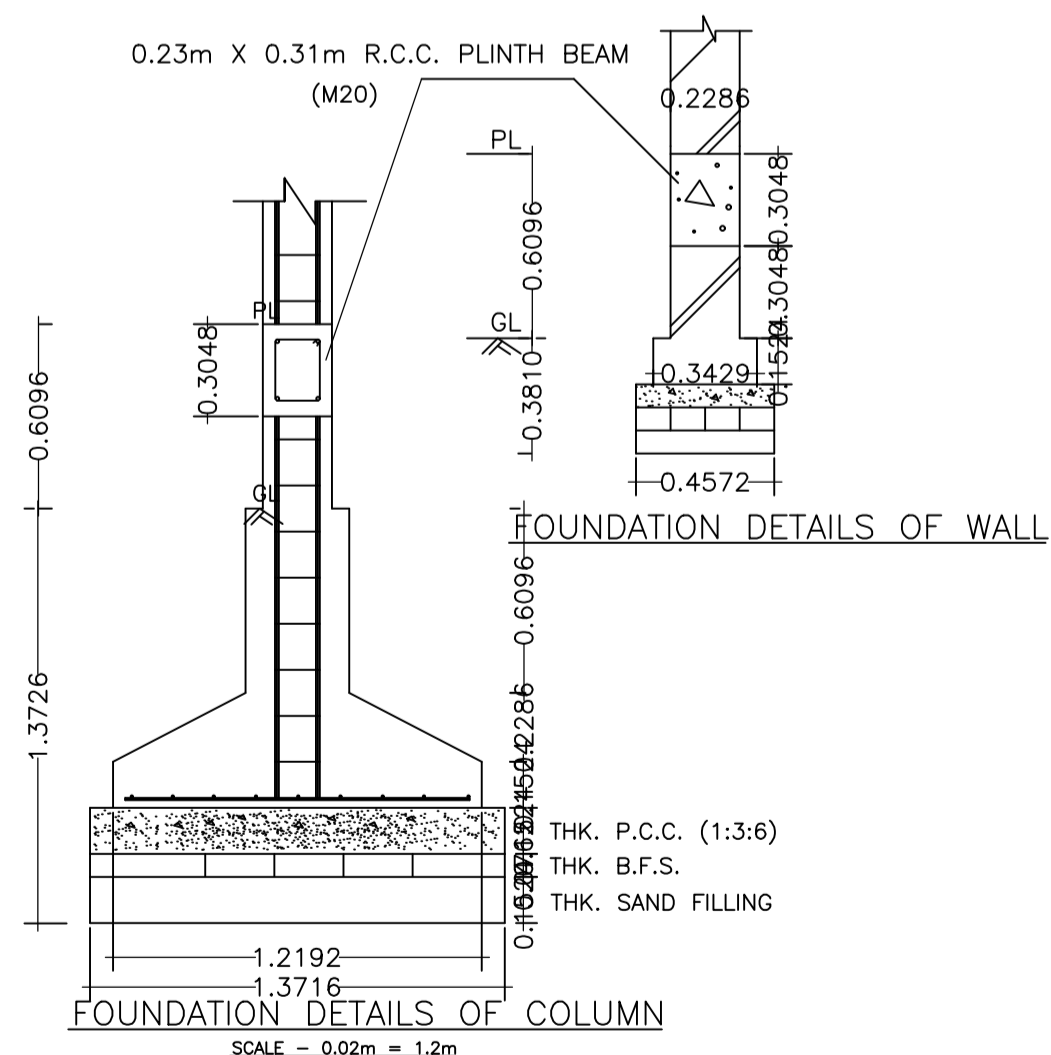
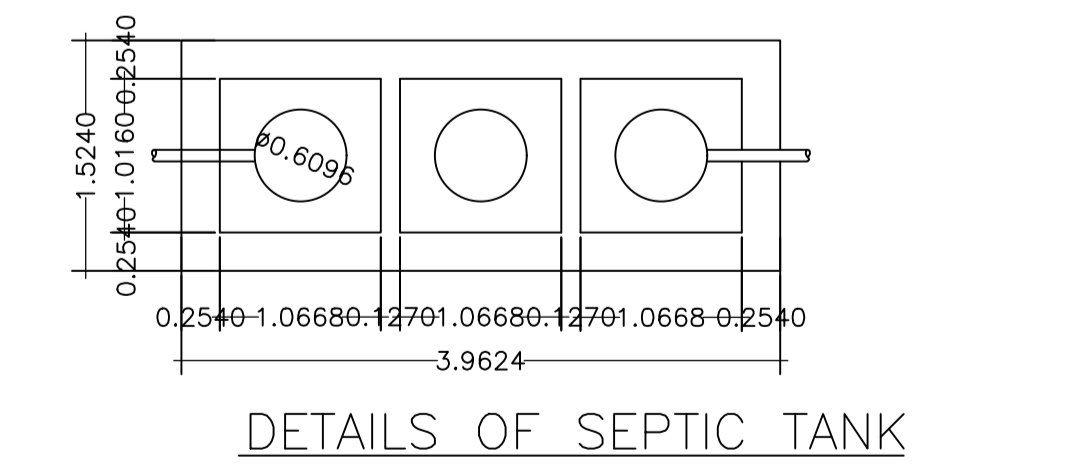
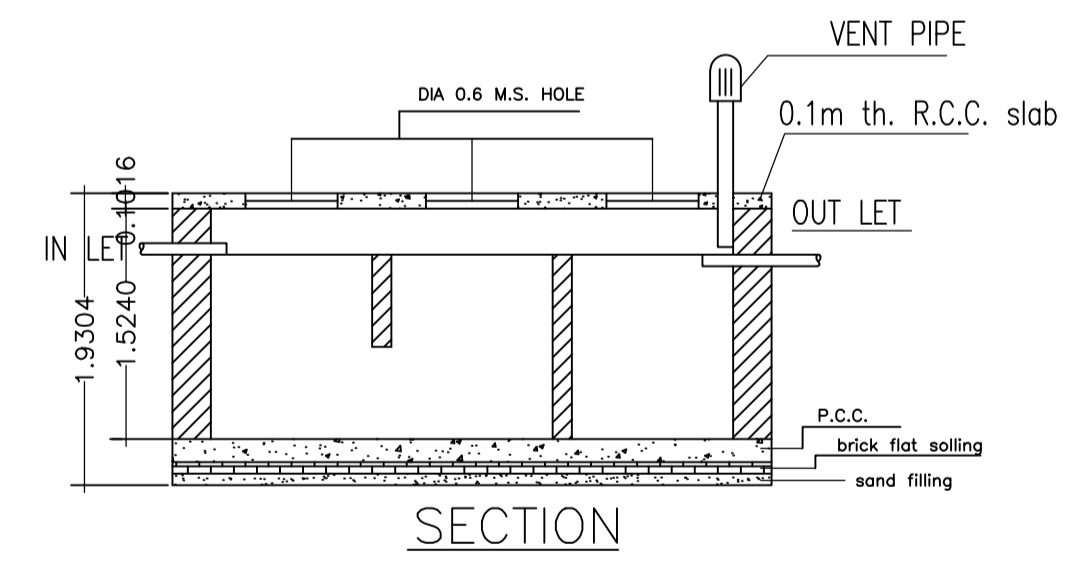
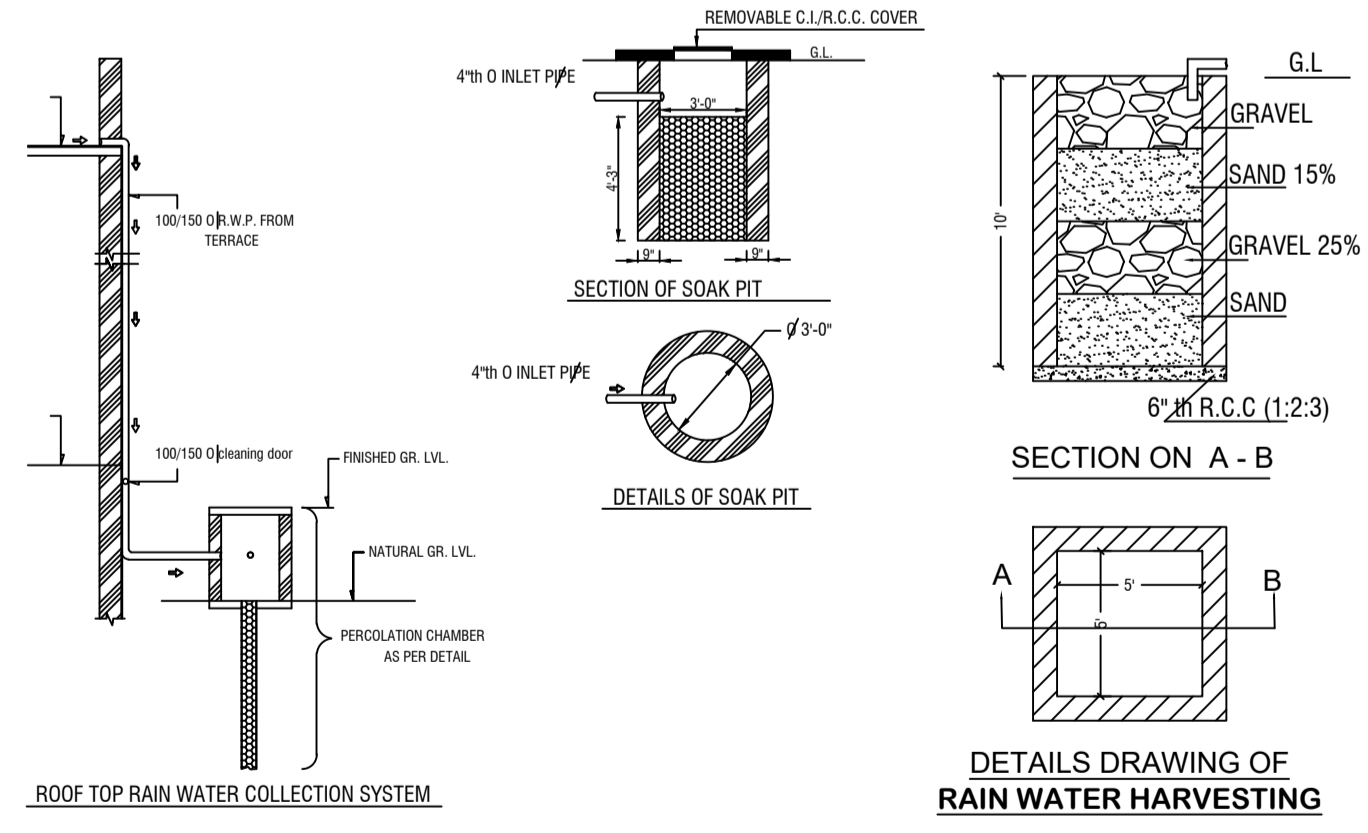

Buildingwise Floor FAR Details

Floor Name	Building Name A (TEJ NARAYAN)		Total	
	Proposed Built Up Area (Sq.mt.)	Proposed FAR Area (Sq.mt.)	Total Proposed Built Up Area (Sq.mt.)	Total FAR Area (Sq.mt.)
Ground Floor	82.84	81.68	82.84	81.68
First Floor	81.68	81.68	81.68	81.68
Terrace Floor	0.00	0.00	0.00	0.00
Total:	164.52	163.36	164.52	163.36

Building USE/SUBUSE Details

Building Name	Building Use	Bungalow/ Dwelling / Non Apartment	Building Structure
A (TEJ NARAYAN)	Residential	Bungalow/ Dwelling / Non Apartment	Non-Highrise

Building :A (TEJ NARAYAN)

Floor Name	Total Built Up Area (Sq.mt.)	Deductions (Area in Sq.mt.) StairCase	Proposed FAR Area (Sq.mt.) Resi.	Total FAR Area (Sq.mt.)	Total Consumed Additional FAR Area (Sq.mt.)	Trmt (No.)
Ground Floor	82.84	1.16	81.68	81.68	81.68	01
First Floor	81.68	0.00	81.68	81.68	81.68	00
Terrace Floor	0.00	0.00	0.00	0.00	0.00	00
Total:	164.52	1.16	163.36	163.36	163.36	01
Total Number of Same Buildings	1					
Total:	164.52	1.16	163.36	163.36	163.36	01

LTP NAME AND SIGNATURE	STRUCTURAL ENG'S NAME AND SIGNATURE	BUILDER NAME AND SIGNATURE	DIGITAL SIGNATURE
RAM PRATAP SINGH MADA/ARC/0024/2019			

Proposal Basic Information	
Proposal File No.	MADA/BP/0172/2021
Owner Name	SRI. TEJ NARAYAN SHARMA
Khata No	OLD KHATA NO-43,NEW KHATA NO-350
Plot No	OLD PLOT NO. 2526, NEW PLOT NO. 4003
Village Name	Bara Pichri
Use	Residential
SubUse	Bungalow/ Dwelling / Non Apartment

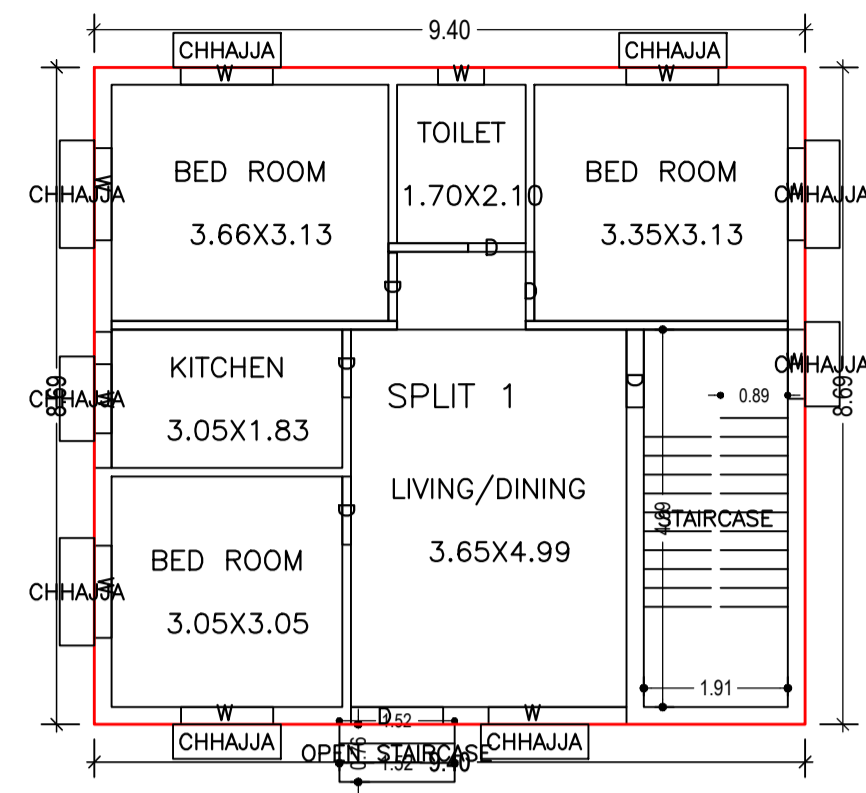

GROUND FLOOR PLAN
(Proposed)
(SCALE 1:100)

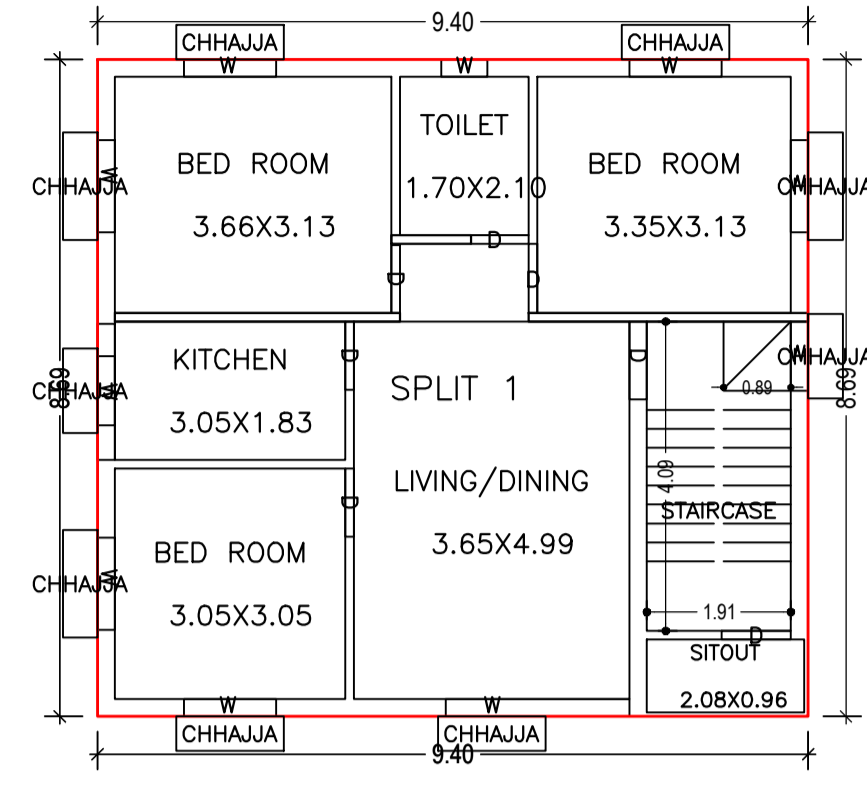

FIRST FLOOR PLAN
(Proposed)
(SCALE 1:100)

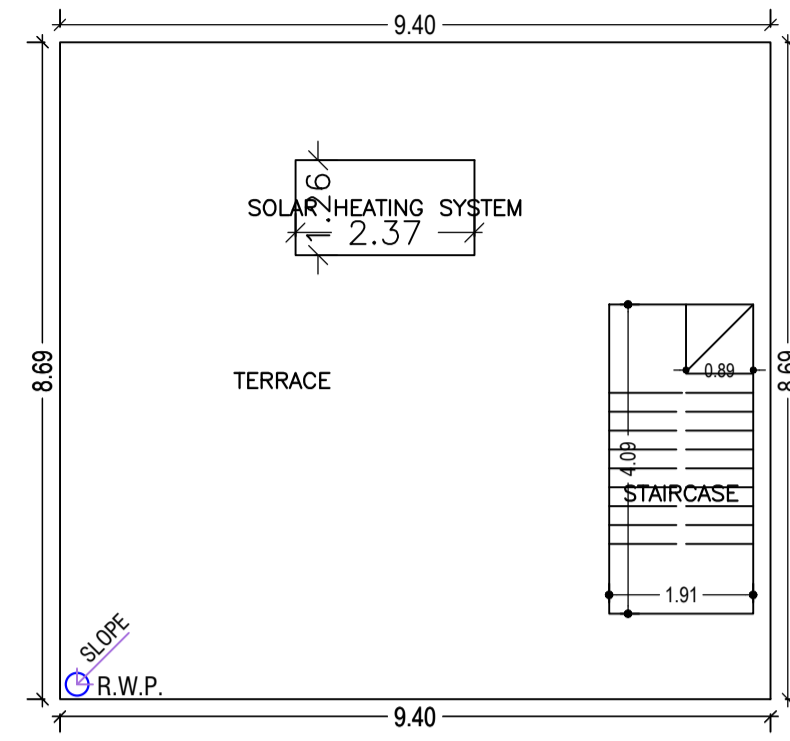

TERRACE FLOOR PLAN
(SCALE 1:100)

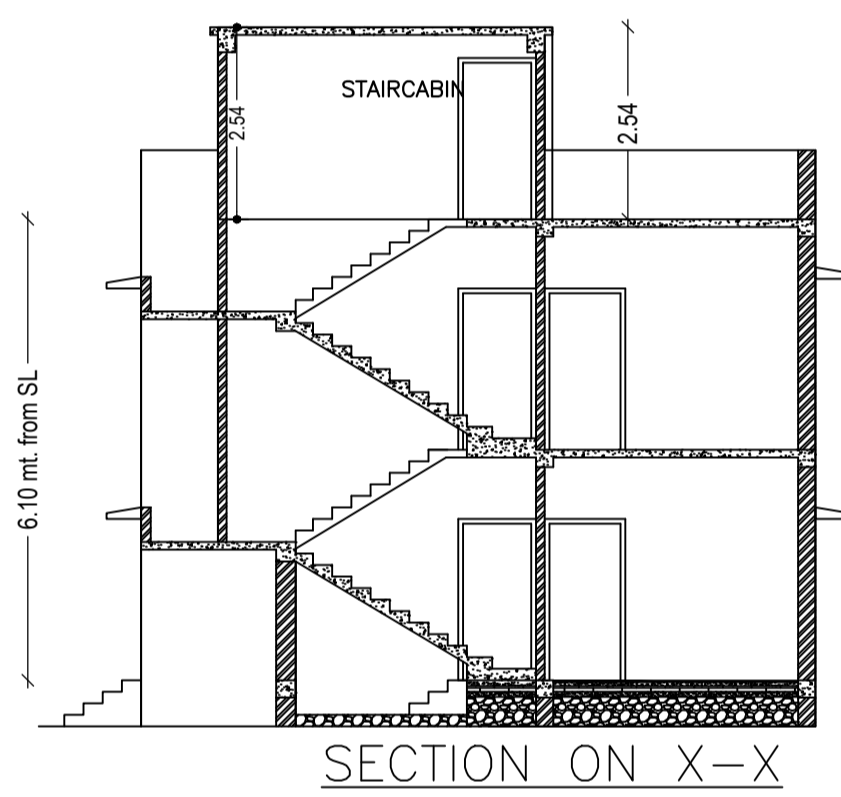
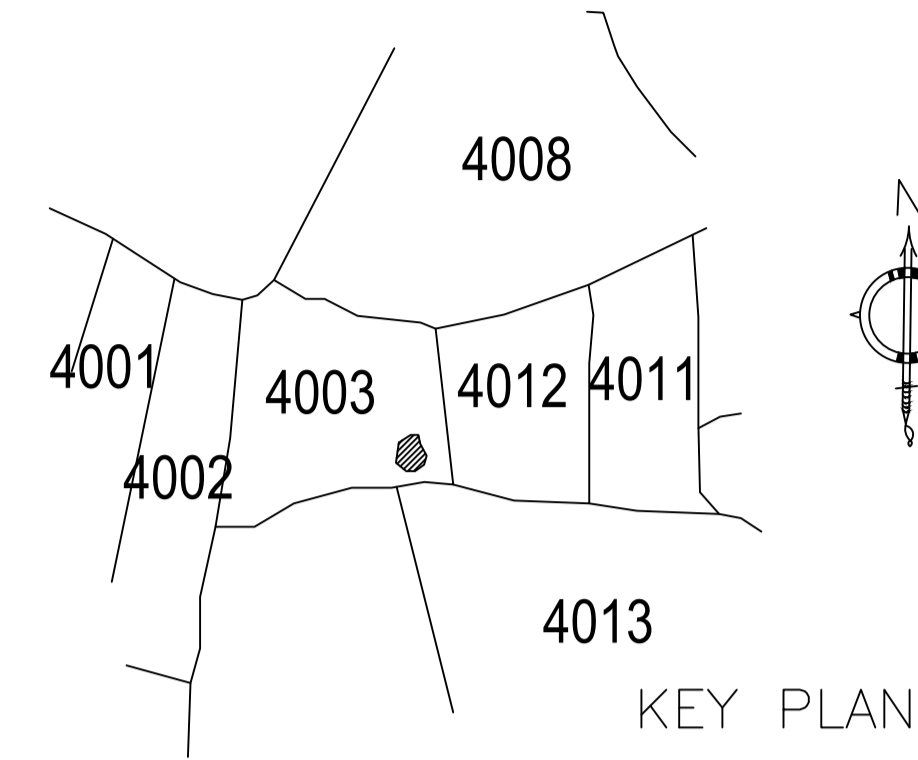

SECTION ON X-X

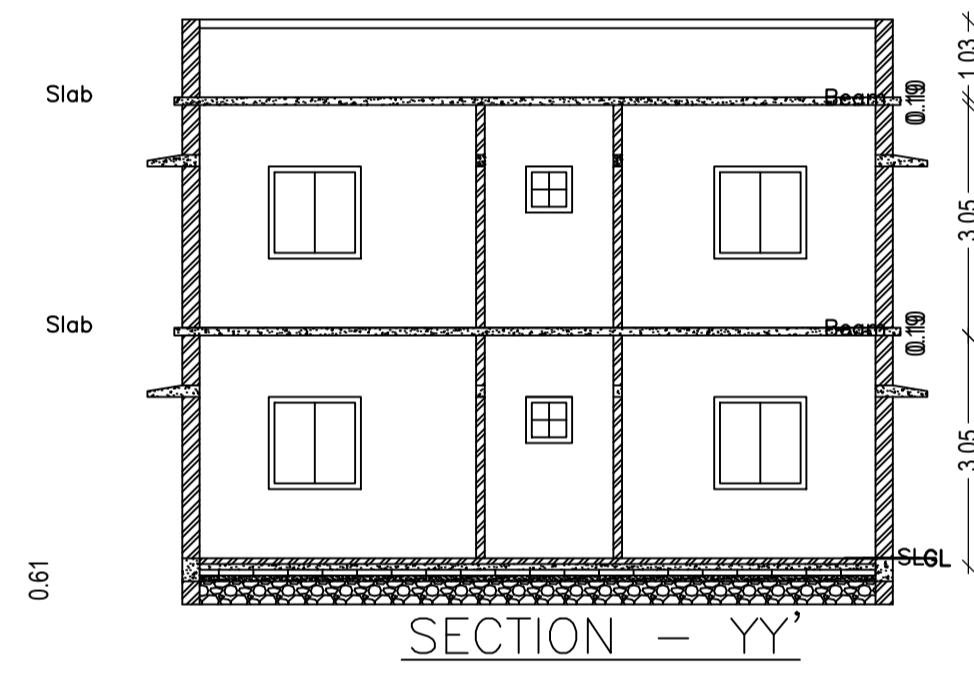

SECTION - YY'

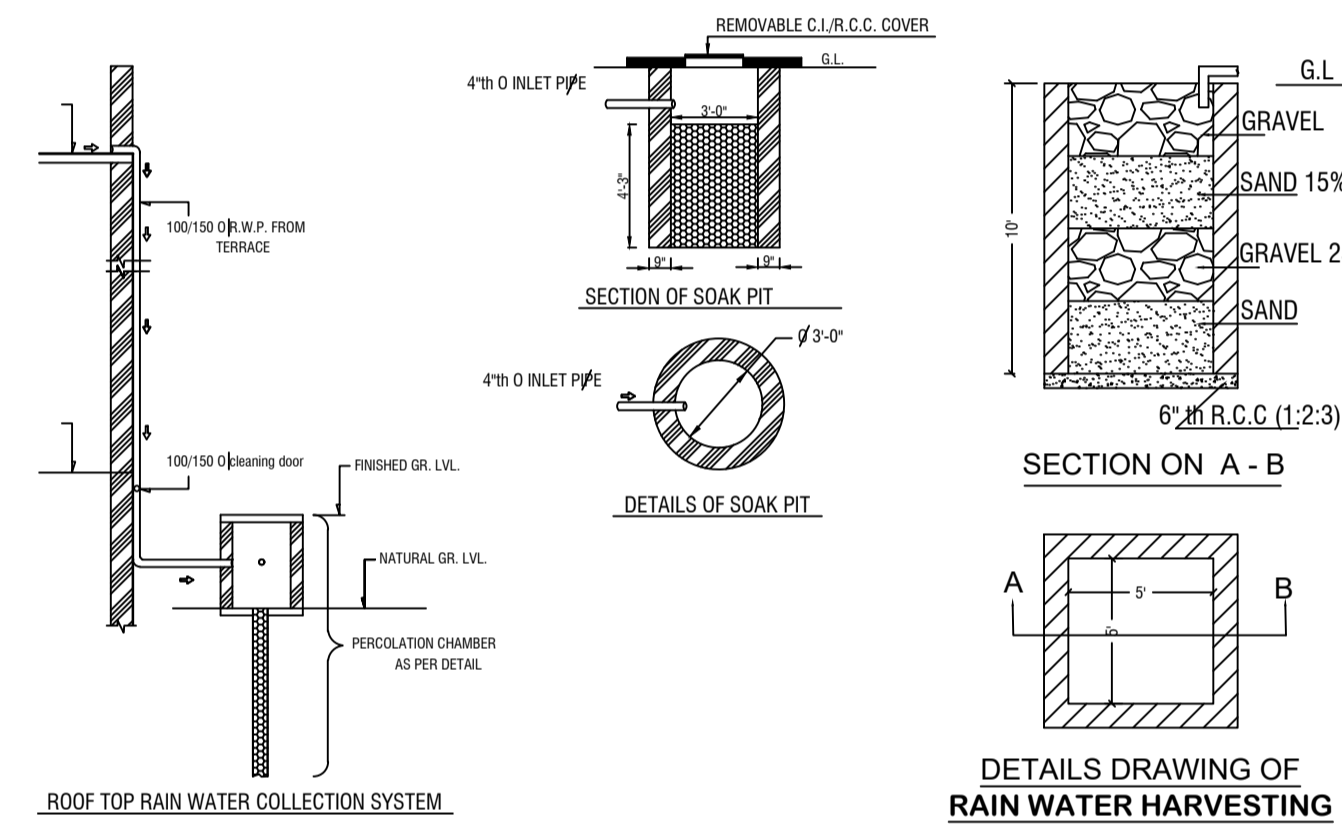

DETAILS DRAWING OF RAIN WATER HARVESTING

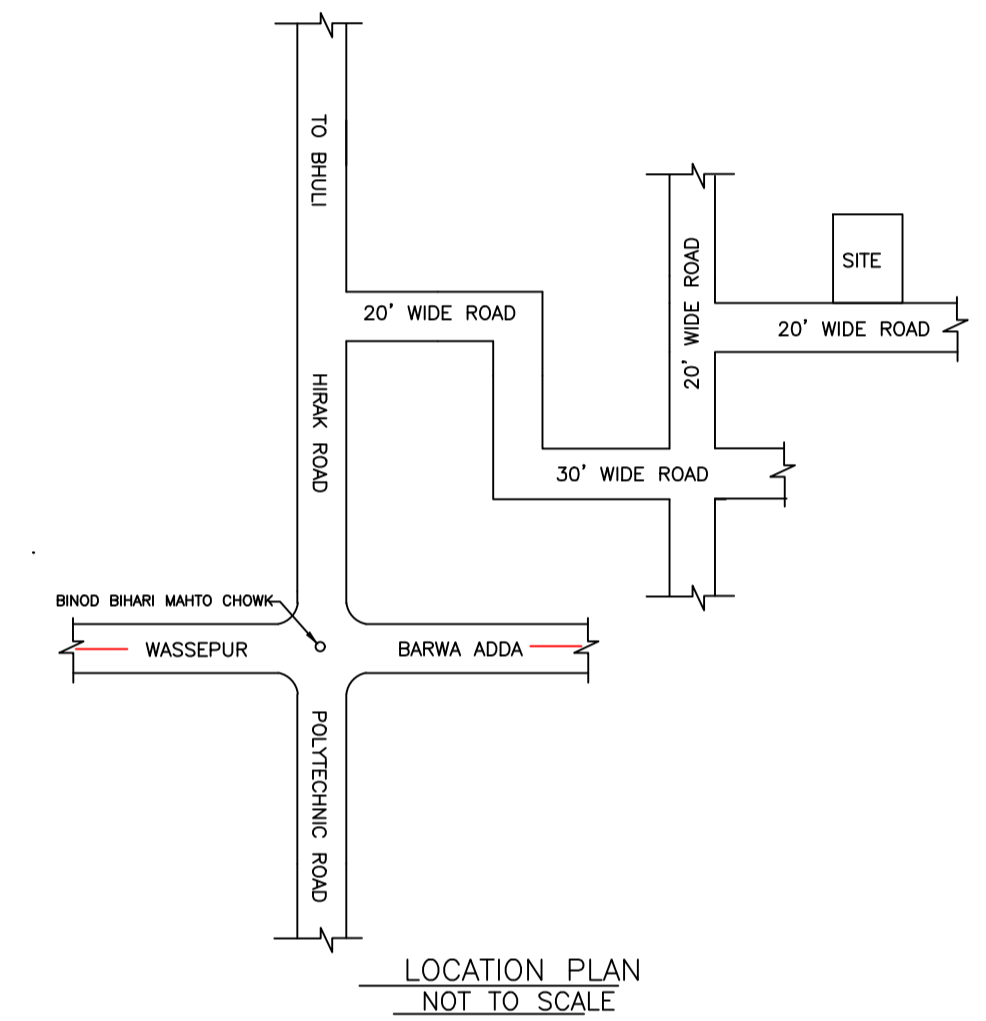

LOCATION PLAN
NOT TO SCALE



FRONT ELEVATION

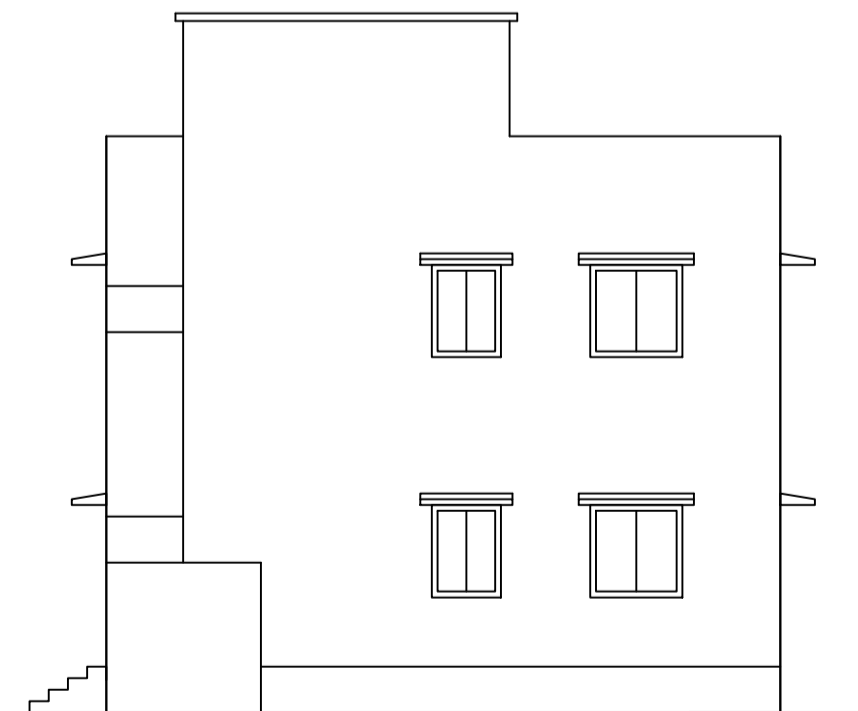

RIGHT ELEVATION

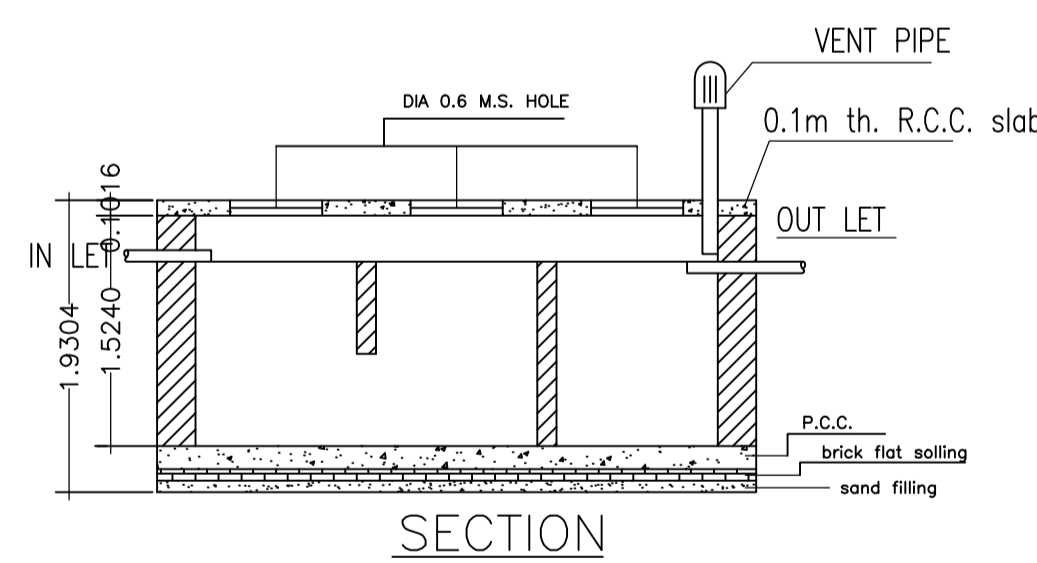

SECTION

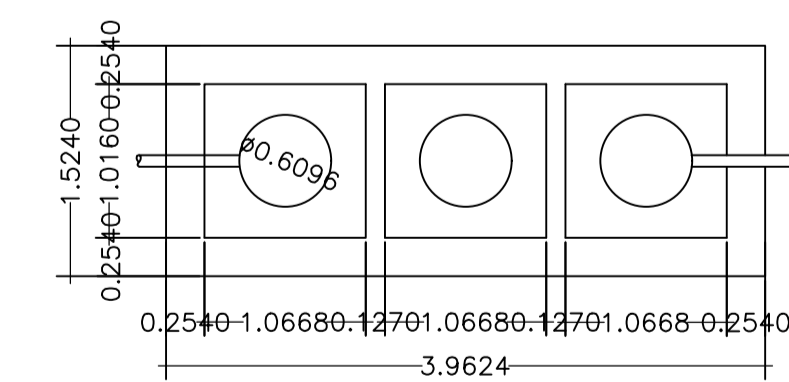

DETAILS OF SEPTIC TANK

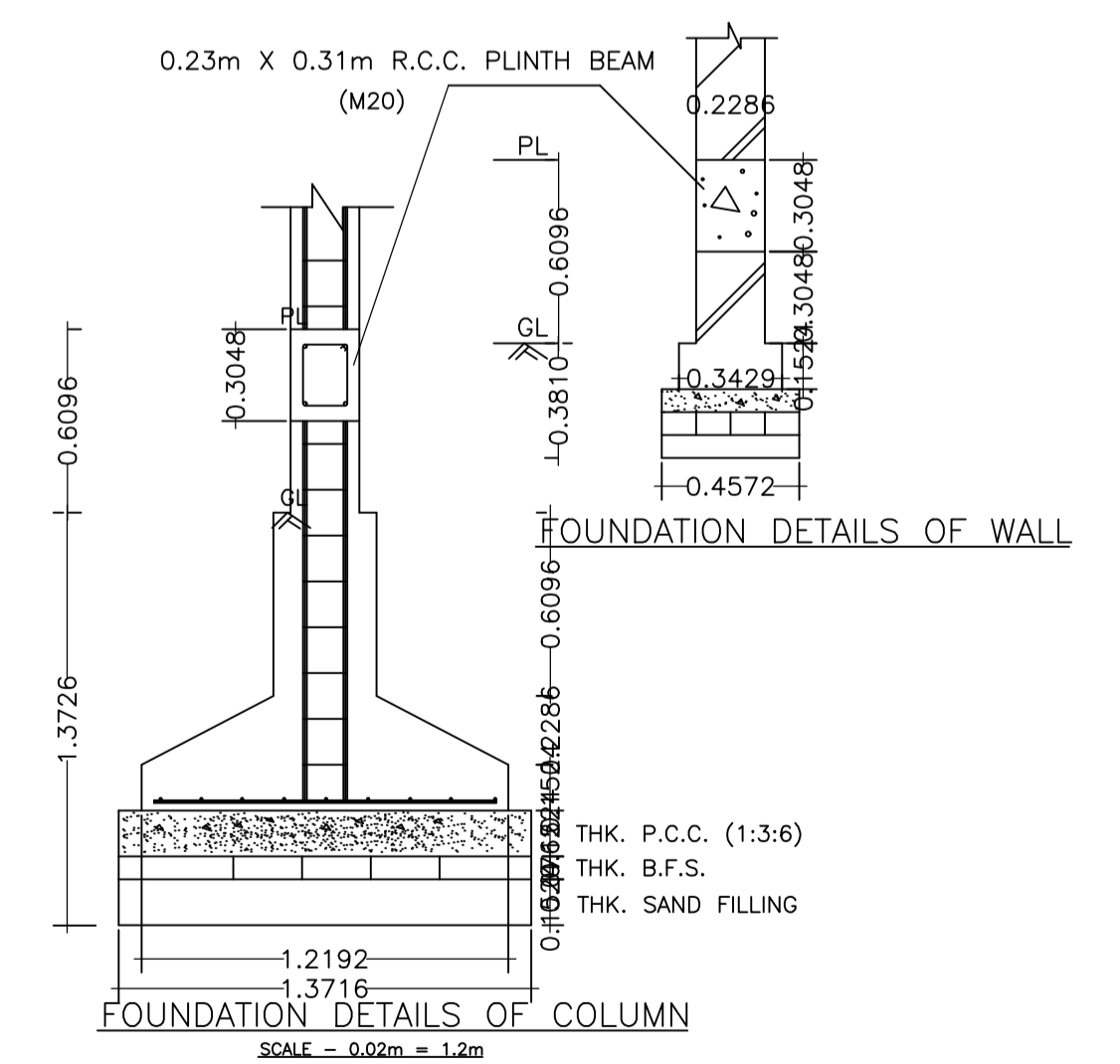

FOUNDATION DETAILS OF WALL

FOUNDATION DETAILS OF COLUMN
SCALE = 0.02m = 1.2m

LTP NAME AND SIGNATURE	STRUCTURAL ENG'S NAME AND SIGNATURE	BUILDER NAME AND SIGNATURE	DIGITAL SIGNATURE
RAM PRATAP SINGH MADA/ARC/0024/2019			