

SITE PLAN  
SCALE :- 1IN=200

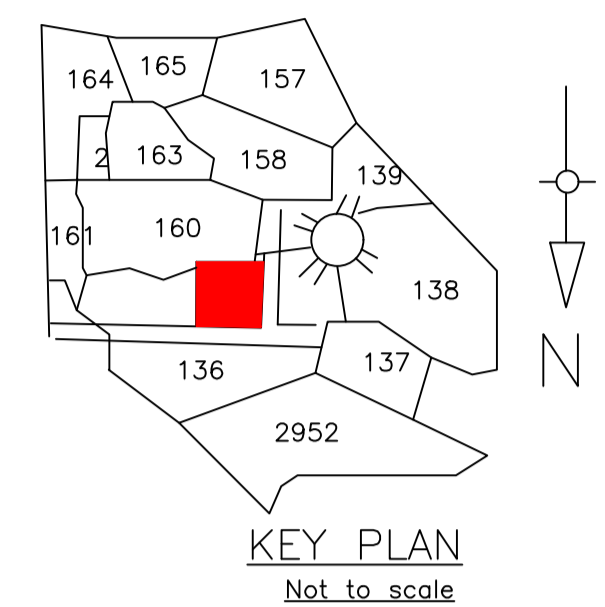

KEY PLAN  
Not to scale

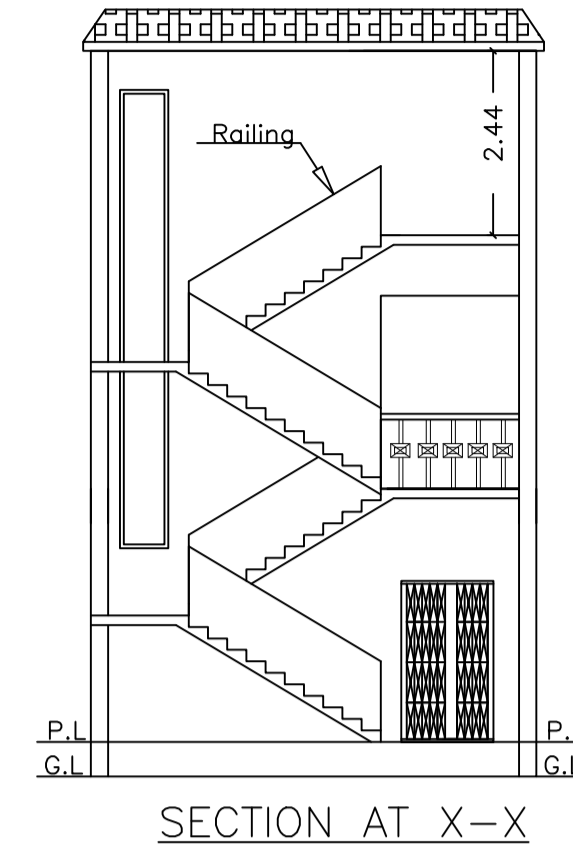

SECTION AT X-X

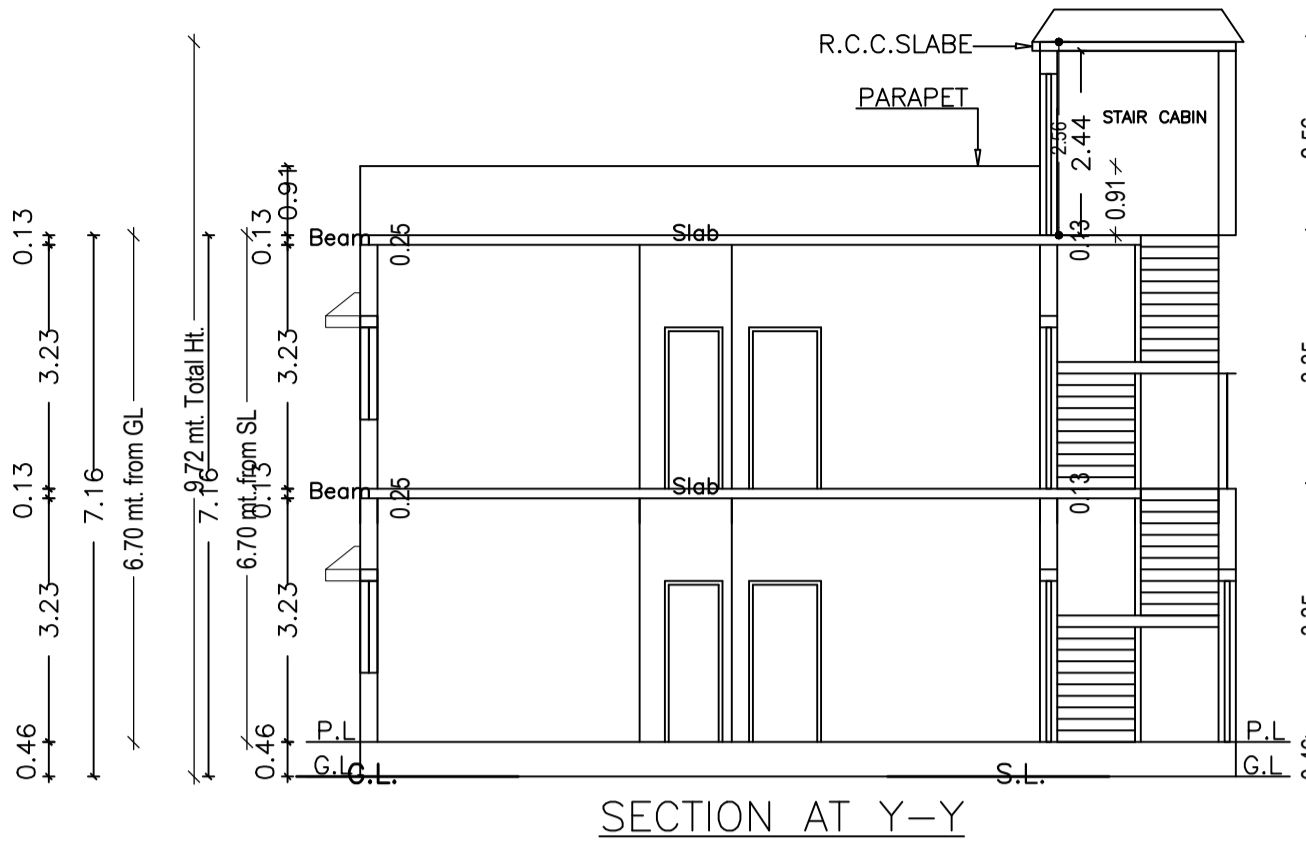

SECTION AT Y-Y

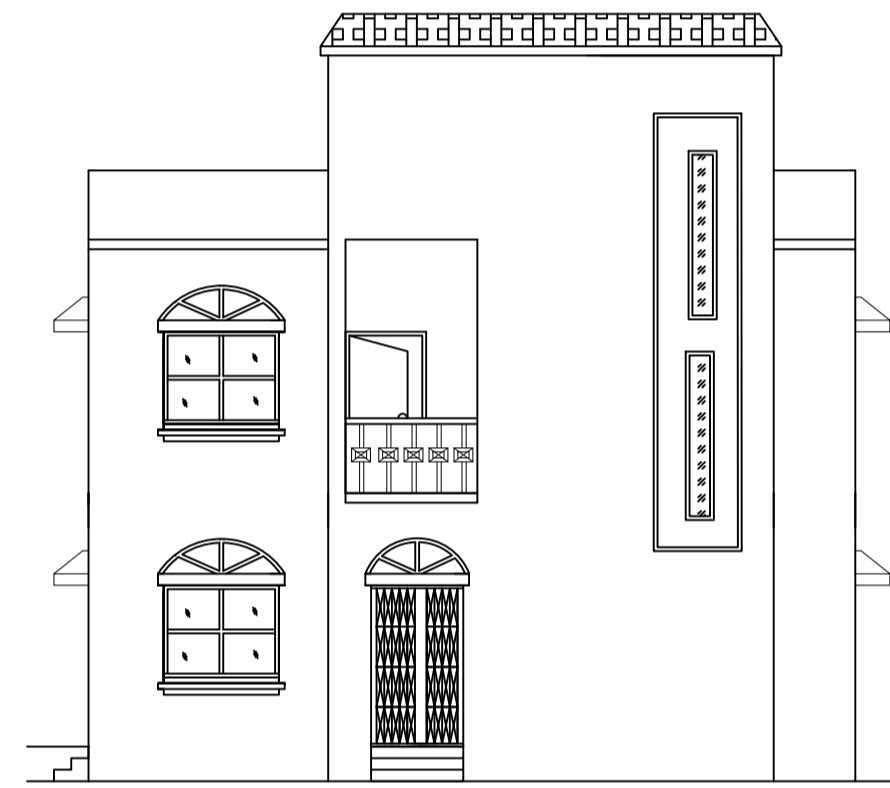

FRONT ELEVATION



LEFT SIDE ELEVATION

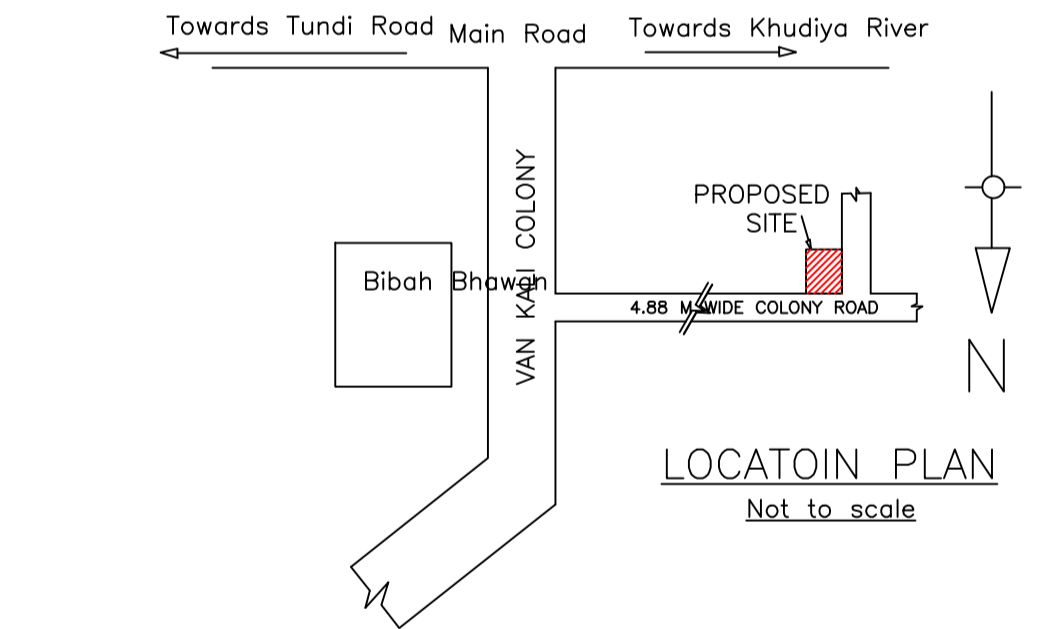

LOCATION PLAN  
Not to scale

SCHEDULE OF DOOR:

BUILDING NAME	NAME	LENGTH	HEIGHT	NOS
A (DAYAMAY)	D	0.69	2.10	02
A (DAYAMAY)	D	0.76	2.10	02
A (DAYAMAY)	D	0.80	2.10	02
A (DAYAMAY)	D	0.91	2.10	04
A (DAYAMAY)	D	0.95	2.10	02
A (DAYAMAY)	D	1.07	2.10	04

SCHEDULE OF WINDOW/VENTILATION:

BUILDING NAME	NAME	LENGTH	HEIGHT	NOS
A (DAYAMAY)	W	0.61	1.20	02
A (DAYAMAY)	W	1.22	1.20	02
A (DAYAMAY)	W	1.52	1.20	12
A (DAYAMAY)	W	1.53	1.20	02

Building :A (DAYAMAY)

Floor Name	Total Built Up Area (Sq.mt.)	Proposed FAR Area (Sq.mt.)	Total FAR Area (Sq.mt.)	Total Consumed Additional FAR Area (Sq.mt.)	Tnmt (No.)
Ground Floor	102.08	102.08	102.08	102.08	01
First Floor	102.08	102.08	102.08	102.08	00
Terrace Floor	0.00	0.00	0.00	0.00	00
Total :	204.16	204.16	204.16	204.16	01
Total Number of Same Buildings :	1				
Total :	204.16	204.16	204.16	204.16	01

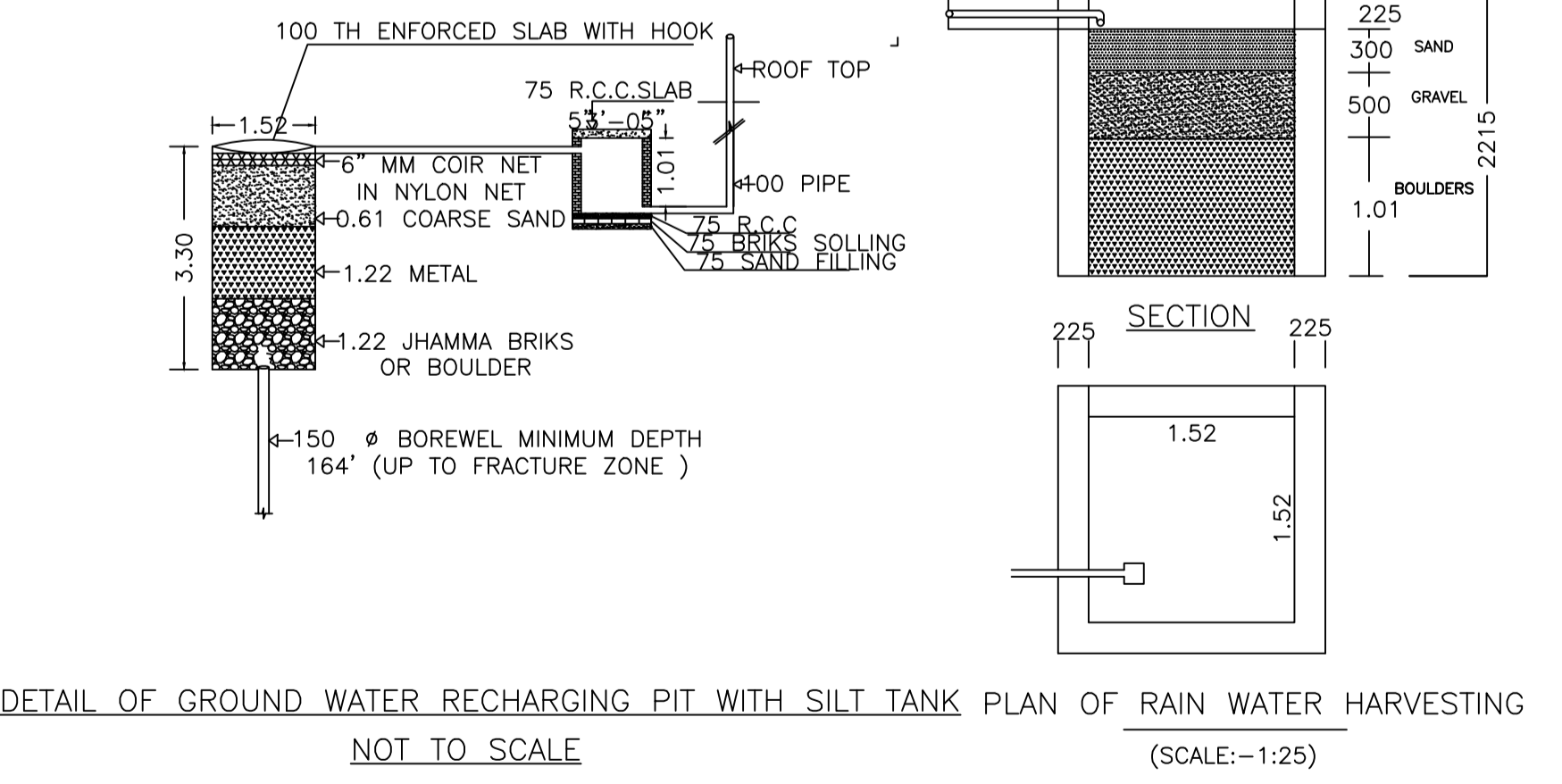

DETAIL OF GROUND WATER RECHARGING PIT WITH SILT TANK PLAN OF RAIN WATER HARVESTING  
NOT TO SCALE

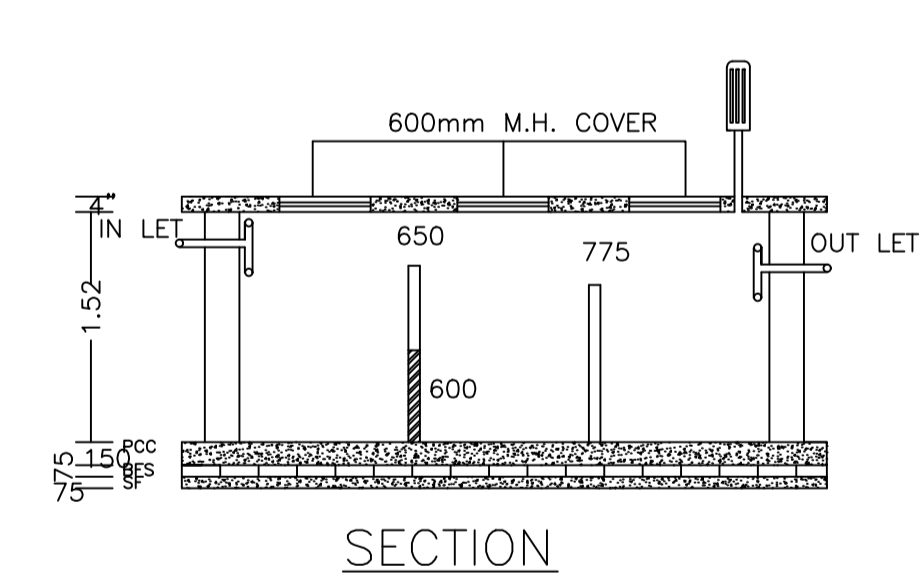

SECTION

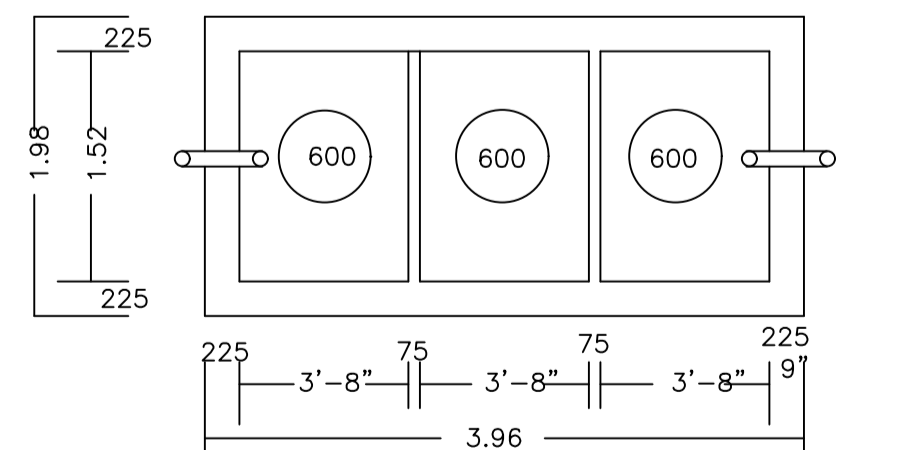

PLAN OF SEPTIC TANK  
(SCALE:- 1:25.)

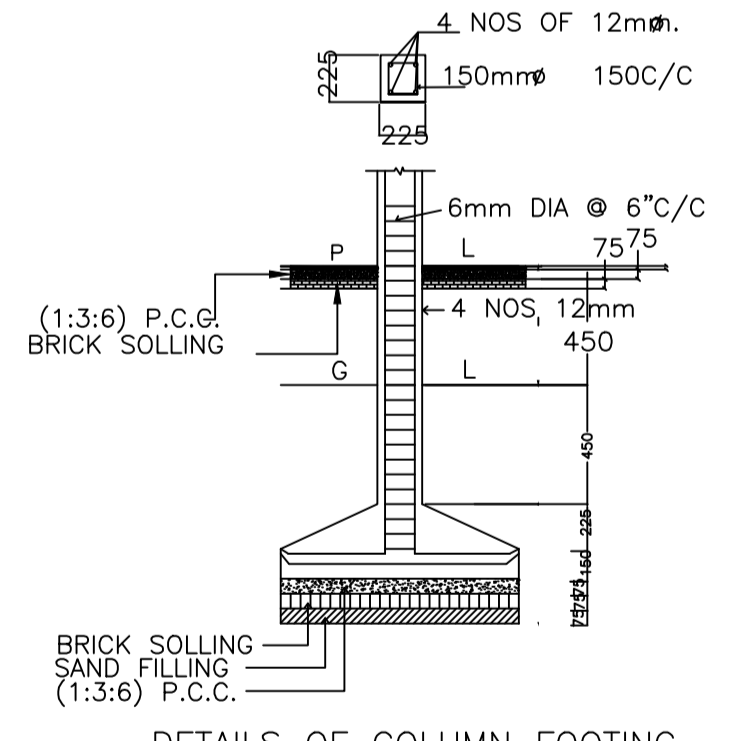

DETAILS OF COLUMN FOOTING

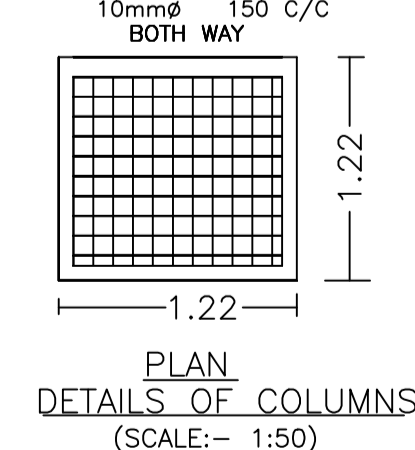

PLAN DETAILS OF COLUMNS  
(SCALE:- 1:50)

Proposal Basic Information

Proposal File No.	MADA/BP/0193/2021
Owner Name	SRI DAYAMAY MUDI
Khata No	90 (OLD) 28 (NEW)
Plot No	111 (OLD) 136 (NEW)
Village Name	Govindpur
Use	Residential
SubUse	Bungalow/ Dwelling / Non Apartment

AREA STATEMENT MINERAL AREA DEVELOPMENT AUTHORITY	VERSION NO.: 1.0.60	VERSION DATE: 16/10/2020
PROJECT DETAIL:	Plot Use: Residential	
Region: JHARKHAND URBAN LOCAL BODIES	Plot SubUse: Bungalow/ Dwelling / Non Apartment	
District: DHANBAD	Plot/ReligiousStructure: NA	
Authority: MINERAL AREA DEVELOPMENT AUTHORITY	Plot/ReligiousStructure: NA	
Inward No: MADA/BP/0193/2021	Plot/SubPlot No: 111 (OLD) 136 (NEW)	
Application Type: General Proposal	North: -	
Project Type: Building Permission	South: -	
Nature of Development: New	East: -	
Location of Development Area: Old Area	West: -	
AREA DETAILS:		SQ.MT.
AREA OF PLOT (Minimum)	(A)	228.34
NET AREA OF PLOT (Gross Plot Area - Deduction from Gross Plot area)	(A-Deductions)	228.34
Deduction for Balance Plot Area (from Gross Plot Area)		
Common Plot		16.24
Total		16.24
BALANCE AREA OF PLOT (Net Plot Area - Recreational/Amenity space)	(A-Deductions)	212.10
PLOT AREA FOR COVERAGE (Net Plot Area)	(A-Deductions)	228.34
Plot Area for FAR (Net Plot Area + Road Widening Area)	(A-Deductions)	228.34
COVERAGE CHECK		
Permissible Coverage area (70.00 %)		159.84
Proposed Coverage Area (44.70 %)		102.08
Total Prop. Coverage Area (44.7 %)		102.08
Balance coverage area (25.30 %)		57.76
FAR CHECK		
Perm. FAR Area (1.80)		411.01
Total Perm. FAR area		411.01
Residential FAR		204.16
Proposed FAR Area		204.16
Total Proposed FAR Area		204.16
Consumed FAR (Factor)		0.89
Balance FAR Area		206.85
BUILT UP AREA CHECK		
Total Proposed BuiltUp Area		204.16
ARCHITECT (Regd)	ANIL KUMAR CHAUDHARY	
ENGINEER (Regd)		
SUPERVISOR (Regd)		
OWNER (Regd)	SRI DAYAMAY MUDI	
DEVELOPMENT AUTHORITY		LOCAL BODY

COLOR INDEX

PLOT BOUNDARY	[Red Line]
ABUTTING ROAD	[Green Line]
PROPOSED CONSTRUCTION	[Yellow Line]
COMMON PLOT	[Blue Line]
ROAD WIDENING AREA	[Orange Line]
EXISTING (To be retained)	[Light Blue Line]
EXISTING (To be demolished)	[Light Yellow Line]

Buildingwise Floor FAR Details

Floor Name	Building Name		Total	
	Proposed Built Up Area (Sq.mt.)	Proposed FAR Area (Sq.mt.)	Total Proposed Built Up Area (Sq.mt.)	Total FAR Area (Sq.mt.)
Ground Floor	102.08	102.08	102.08	102.08
First Floor	102.08	102.08	102.08	102.08
Terrace Floor	0.00	0.00	0.00	0.00
Total :	204.16	204.16	204.16	204.16

Building USE/SUBUSE Details

Building Name	Building Use	Building SubUse	Building Structure
A (DAYAMAY)	Residential	Residential Bldg/Apartment	Non-Highrise

UnitBUA Table for Building :A (DAYAMAY)

FLOOR	Name	UnitBUA Type	UnitBUA Area	Carpet Area	No. of Rooms	No. of Tenement
GROUND FLOOR PLAN	SPLIT 1	FLAT	204.16	202.52	8	1
FIRST FLOOR PLAN	SPLIT 1	FLAT	0.00	0.00	8	0
Total:	-	-	204.16	202.52	16	1

FAR & Tenement Details (Table 4c-1)

Building	No. of Same Bldg	Total Built Up Area (Sq.mt.)	Proposed FAR Area (Sq.mt.)	Total FAR Area (Sq.mt.)	Total Consumed Additional FAR Area (Sq.mt.)	Tnmt (No.)
A (DAYAMAY)	1	204.16	204.16	204.16	204.16	01
Grand Total :	1	204.16	204.16	204.16	204.16	01

LTP NAME AND SIGNATURE	STRUCTURAL ENG'S NAME AND SIGNATURE	BUILDER NAME AND SIGNATURE	DIGITAL SIGNATURE
ANIL KUMAR CHAUDHARY MADA/ENG/0005/2019			



Proposal Basic Information	
Proposal File No.	MADA/BP/0193/2021
Owner Name	SRI DAYAMAY MUDI
Khata No	90 (OLD) 28 (NEW)
Plot No	111 (OLD) 136 (NEW)
Village Name	Govindpur
Use	Residential
SubUse	Bungalow/ Dwelling / Non Apartment

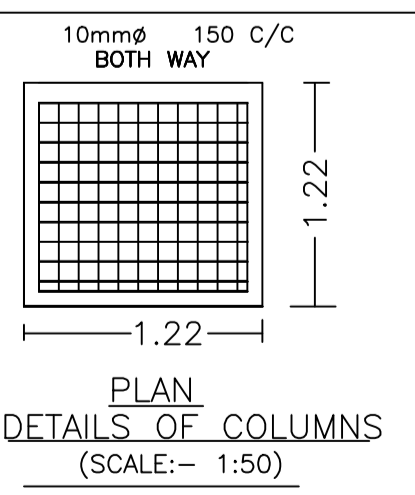
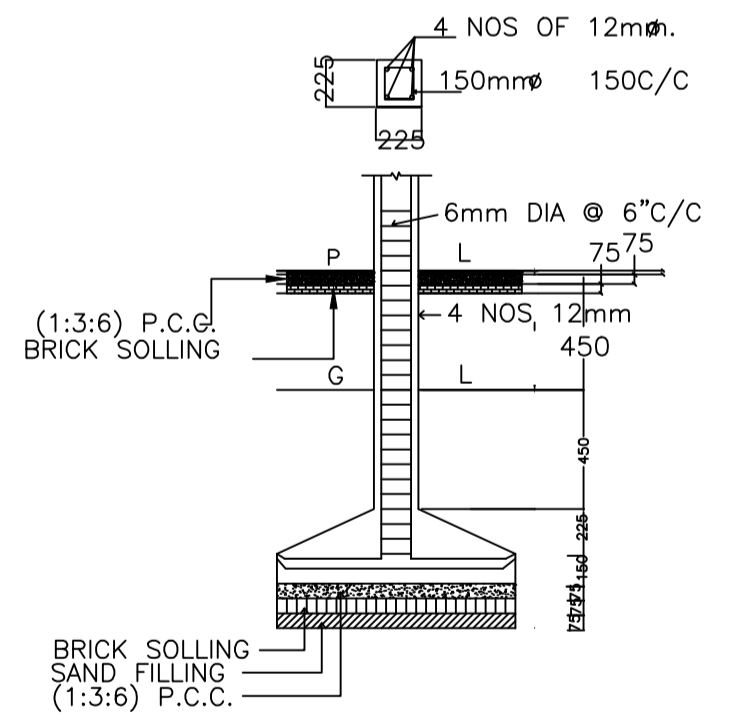
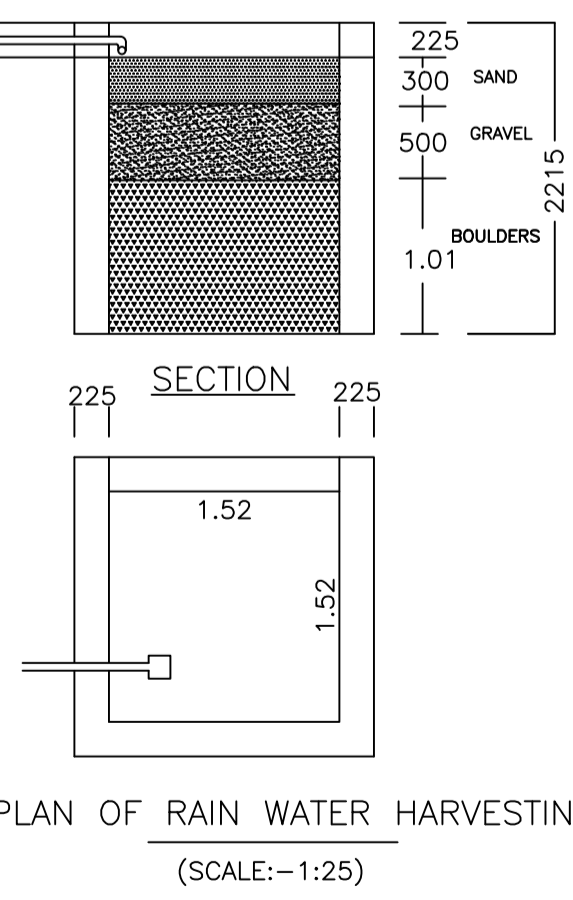
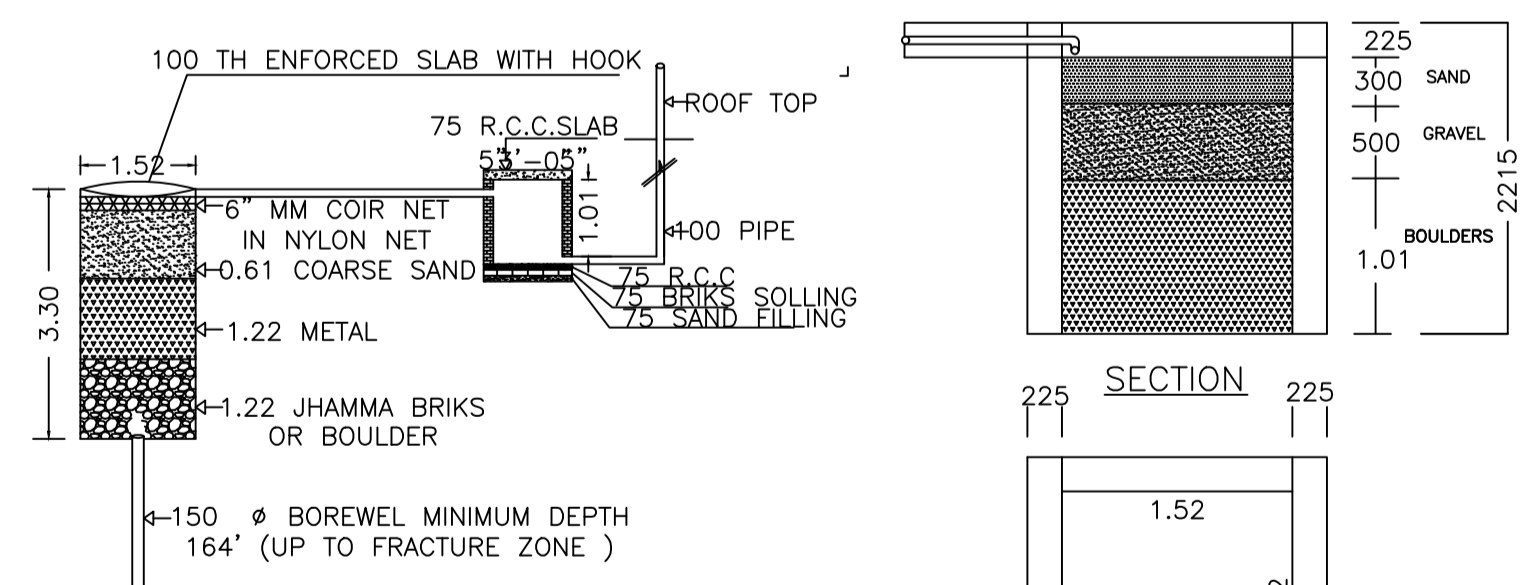
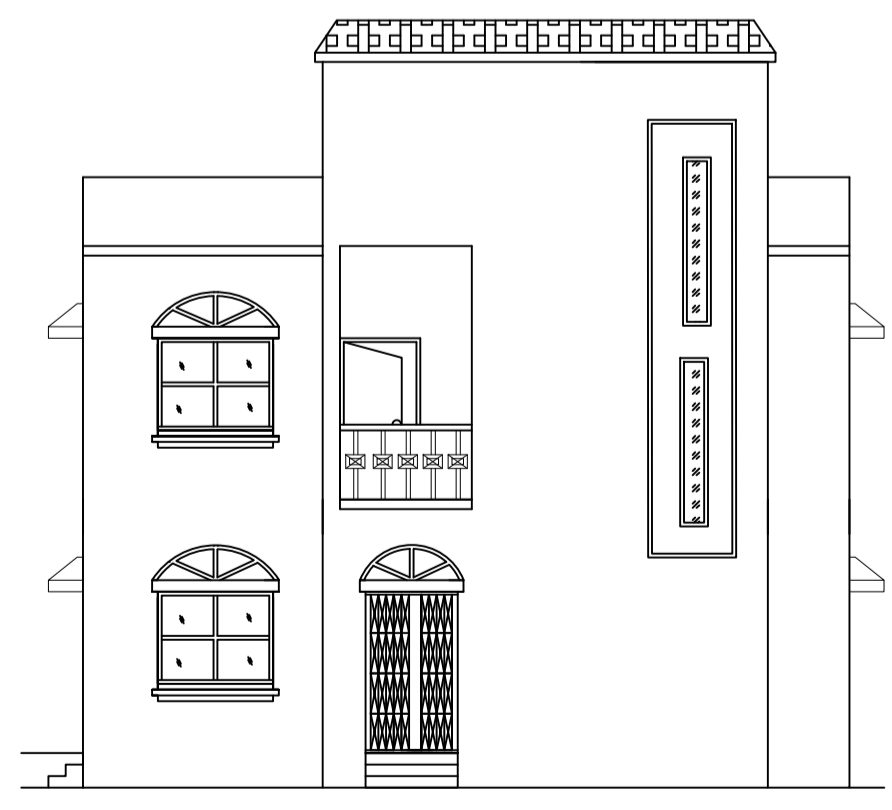
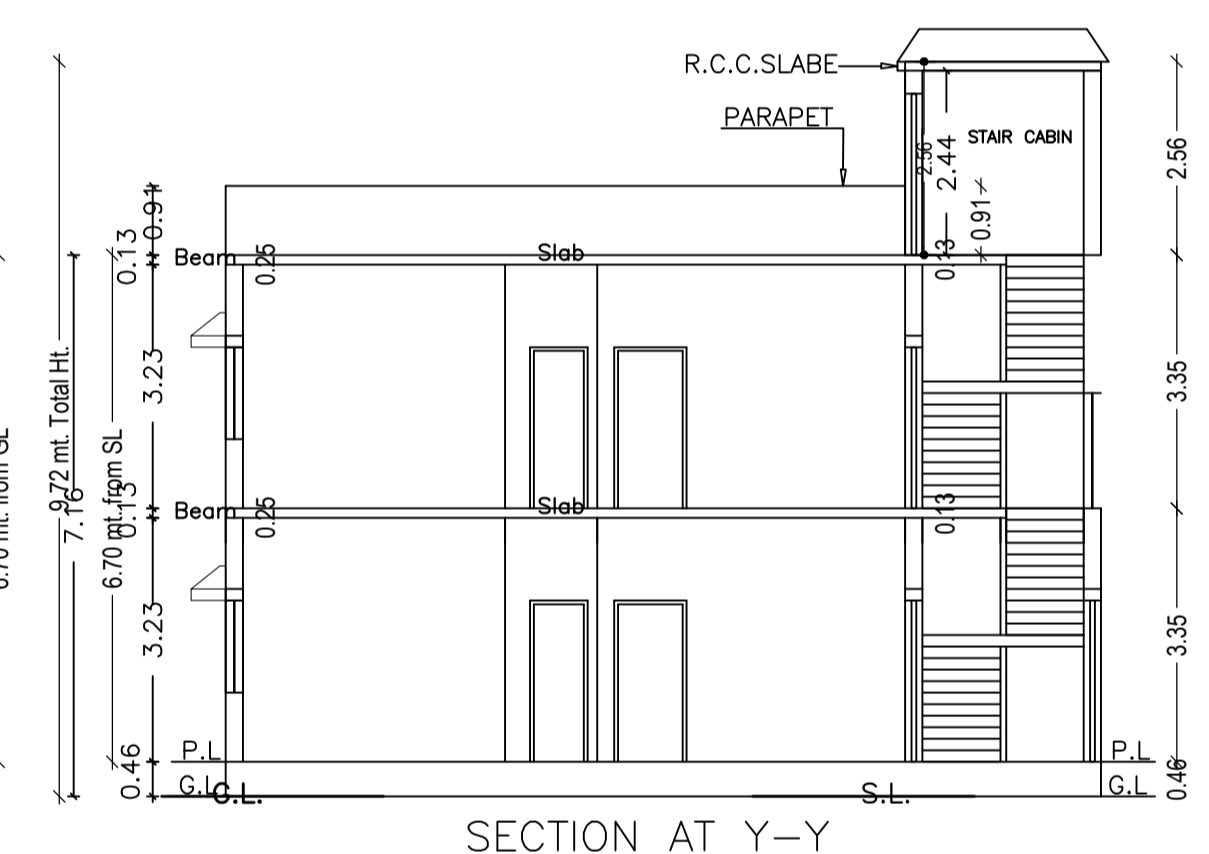
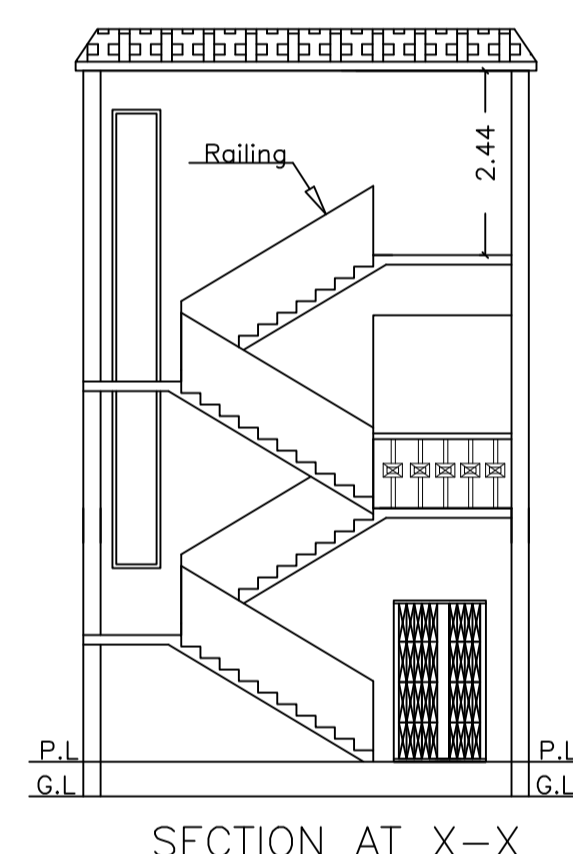
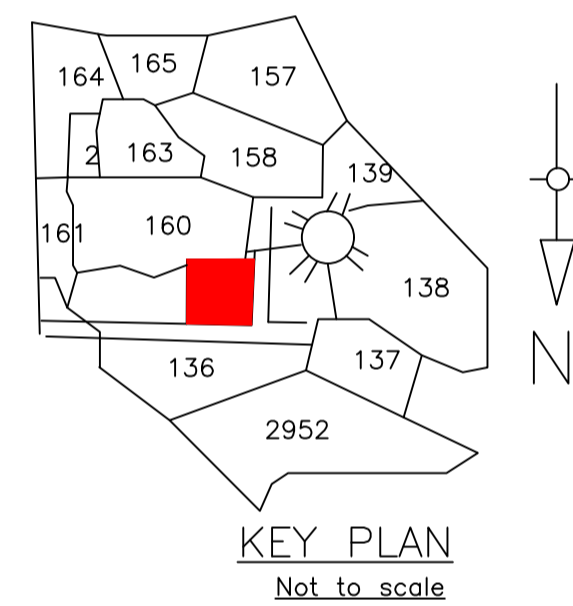
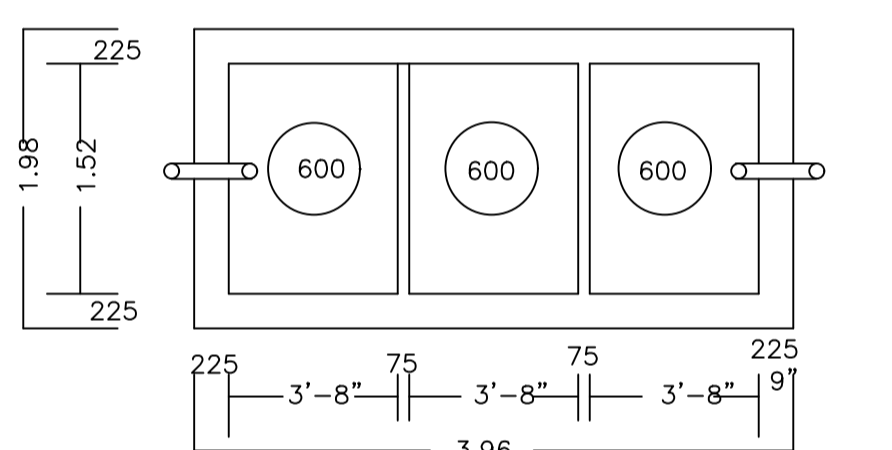
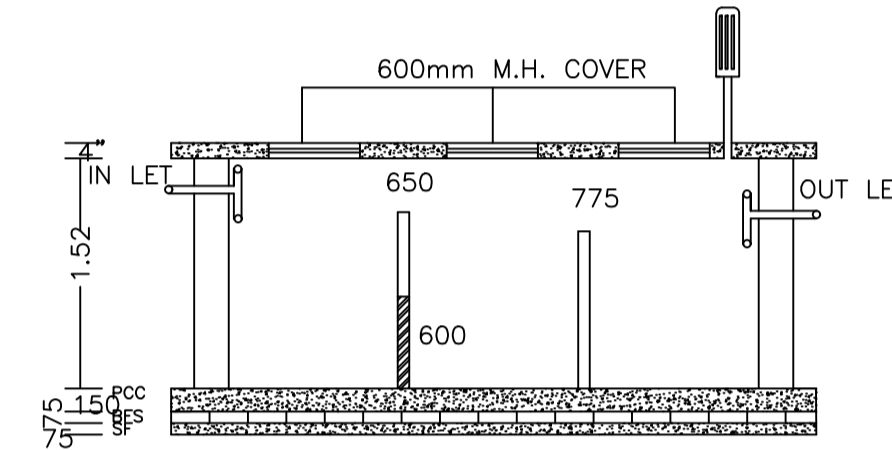
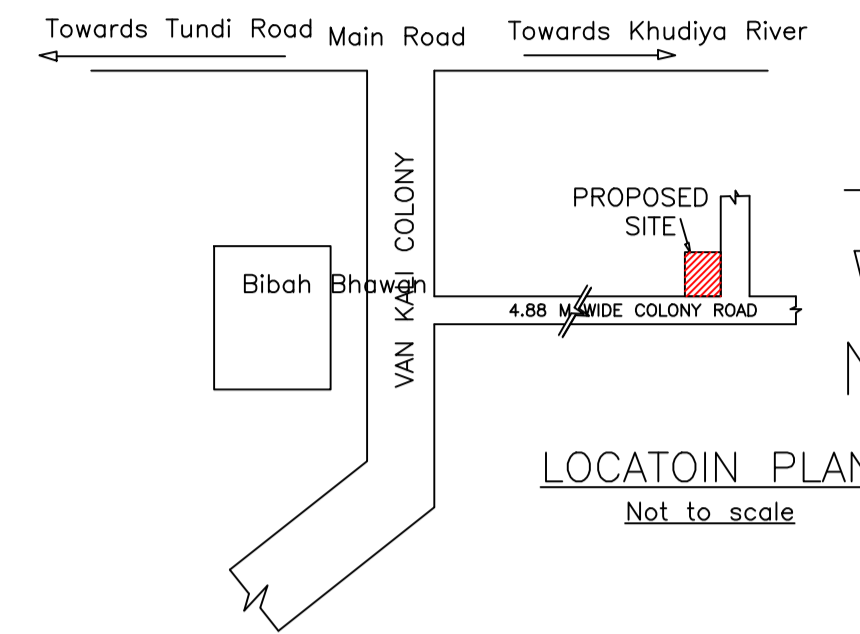
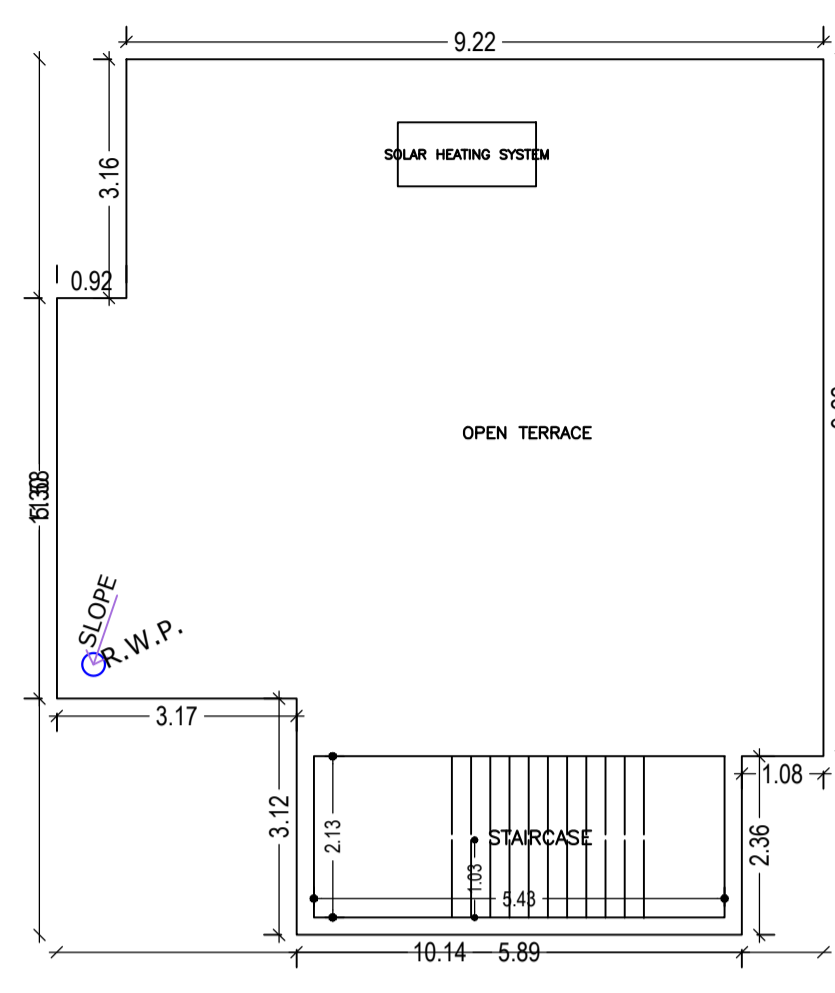
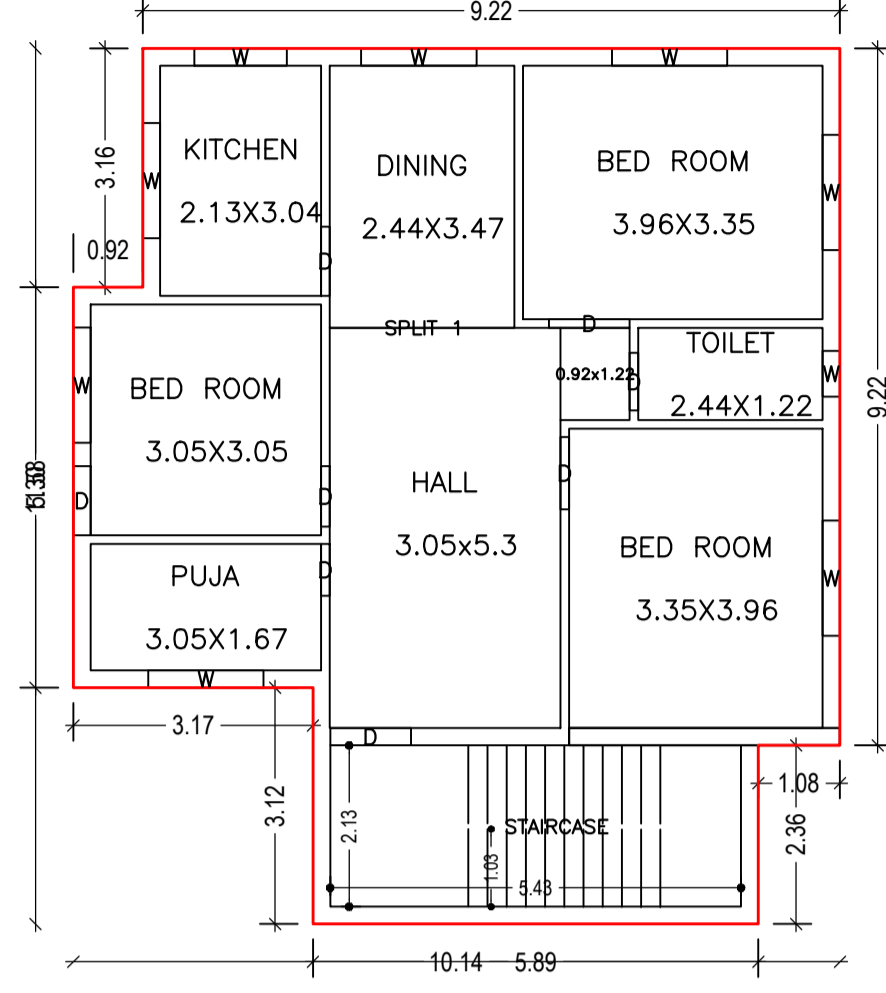
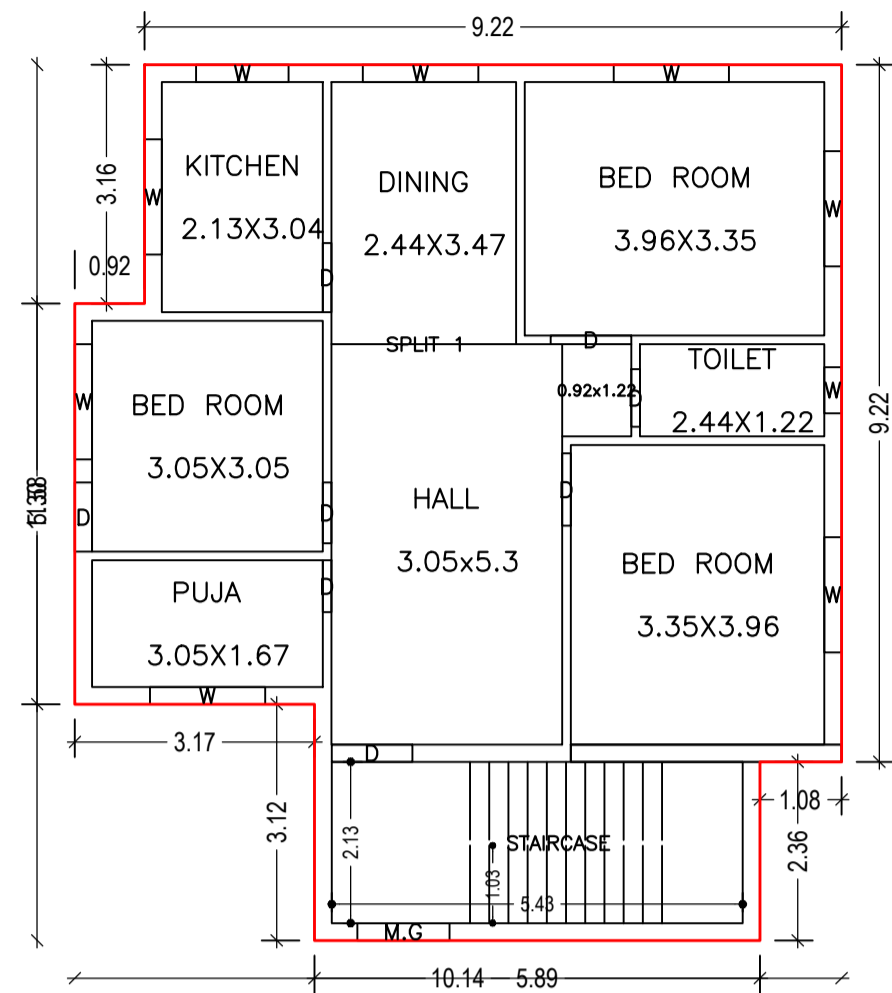

LTP NAME AND SIGNATURE	STRUCTURAL ENG'S NAME AND SIGNATURE	BUILDER NAME AND SIGNATURE	DIGITAL SIGNATURE
ANIL KUMAR CHAUDHARY MADA/ENG/0005/2019			