

Proposal Basic Information

Proposal File No.	MADA/BP/0185/2021
Owner Name	SMT. NIRMALA PANDEY
Khata No	OLD KHATA NO-16, NEW KHATA NO-14
Plot No	OLD PLOT NO. 71, NEW PLOT NO. 196
Village Name	Tiakraydih
Use	Residential
SubUse	Bungalow/ Dwelling / Non Apartment

AREA STATEMENT MINERAL AREA DEVELOPMENT AUTHORITY	VERSION NO.: 1.0.60	VERSION DATE: 16/10/2020
PROJECT DETAIL:		
Region: JHARKHAND URBAN LOCAL BODIES	Plot Use: Residential	
District: DHANBAD	Plot SubUse: Bungalow/ Dwelling / Non Apartment	
Authority: MINERAL AREA DEVELOPMENT AUTHORITY	PlotNearbyReligiousStructure: NA	
Inward No: MADA/BP/0185/2021	Plot/SubPlot No: OLD PLOT NO. 71, NEW PLOT NO. 196	
Application Type: General Proposal	North: Plot No. - SAME PLOT	
Project Type: Building Permission	South: Plot No. - SAME PLOT	
Nature of Development: New	East: Road Width - 6.10	
Location of Development Area: Old Area	West: Plot No. - SAME PLOT	
AREA DETAILS:		
AREA OF PLOT (Minimum)	(A)	SQ.MT. 138.76
NET AREA OF PLOT(Gross Plot Area - Deduction from Gross Plot area)	(A-Deductions)	138.76
Deduction for Balance Plot Area(from Gross Plot Area)		
Common Plot		14.07
Total		14.07
BALANCE AREA OF PLOT(Net Plot Area - Recreational/Amenity space)	(A-Deductions)	124.69
PLOT AREA FOR COVERAGE(Net Plot Area)	(A-Deductions)	138.76
Plot Area for FAR (Net Plot Area + Road Widening Area)	(A-Deductions)	138.76
COVERAGE CHECK		
Permissible Coverage area (70.00 %)		97.13
Proposed Coverage Area (47.08 %)		65.32
Total Prop. Coverage Area (47.08 %)		65.32
Balance coverage area (22.93 %)		31.81
FAR CHECK		
Perm. FAR Area (2.50)		346.90
Total Perm. FAR area		346.90
Residential FAR		147.26
Proposed FAR Area		147.26
Total Proposed FAR Area		147.26
Consumed FAR (Factor)		1.06
Balance FAR Area		199.64
BUILT UP AREA CHECK		
Total Proposed BuiltUp Area		163.88
ARCHITECT (Regd)		RAM PRATAP SINGH
ENGINEER (Regd)		
SUPERVISOR (Regd)		
OWNER (Regd)		SMT. NIRMALA PANDEY
DEVELOPMENT AUTHORITY LOCAL BODY		

COLOR INDEX

PLOT BOUNDARY	Black
ABUTTING ROAD	Green
PROPOSED CONSTRUCTION	Red
COMMON PLOT	Yellow
ROAD WIDENING AREA	Orange
EXISTING (To be retained)	Blue
EXISTING (To be demolished)	Light Blue

Buildingwise Floor FAR Details

Floor Name	Building Name		Total	
	Proposed Built Up Area (Sq.mt.)	Proposed FAR Area (Sq.mt.)	Total Proposed Built Up Area (Sq.mt.)	Total FAR Area (Sq.mt.)
Ground Floor	81.94	65.32	81.94	65.32
First Floor	81.94	81.94	81.94	81.94
Terrace Floor	0.00	0.00	0.00	0.00
Total :	163.88	147.26	163.88	147.26

Building USE/SUBUSE Details

Building Name	Building Use	Building SubUse	Building Structure
A (NIRMALA)	Residential	Bungalow/ Dwelling / Non Apartment	Non-Highrise

UnitBUA Table for Building :A (NIRMALA)

FLOOR	Name	UnitBUA Type	UnitBUA Area	Carpet Area	No. of Rooms	No. of Tenement
GROUND FLOOR PLAN	SPLIT 1	FLAT	147.26	146.60	5	1
FIRST FLOOR PLAN	SPLIT 1	FLAT	0.00	0.00	7	0
Total:	-	-	147.26	146.60	12	1

FAR & Tenement Details (Table 4c-1)

Building	No. of Same Bldg	Total Built Up Area (Sq.mt.)	Deductions (Area in Sq.mt.)	Proposed FAR Area (Sq.mt.)	Total FAR Area (Sq.mt.)	Total Consumed Additional FAR Area (Sq.mt.)	Tnmt (No.)
A (NIRMALA)	1	163.88	16.62	147.26	147.26	147.26	01
Grand Total :	1	163.88	16.62	147.26	147.26	147.26	01

SCHEDULE OF DOOR:

BUILDING NAME	NAME	LENGTH	HEIGHT	NOS
A (NIRMALA)	D	0.76	2.10	02
A (NIRMALA)	D	0.79	2.10	01
A (NIRMALA)	D	0.91	2.10	01
A (NIRMALA)	D	0.93	2.10	01
A (NIRMALA)	D	0.97	2.10	01
A (NIRMALA)	D	1.00	2.10	01
A (NIRMALA)	D	1.07	2.10	04
A (NIRMALA)	D	1.52	2.10	01

SCHEDULE OF WINDOW/VENTILATION:

BUILDING NAME	NAME	LENGTH	HEIGHT	NOS
A (NIRMALA)	W	0.84	1.20	03
A (NIRMALA)	W	1.22	1.20	01
A (NIRMALA)	W	1.52	1.20	10
A (NIRMALA)	W	2.55	1.20	02

Building :A (NIRMALA)

Floor Name	Total Built Up Area (Sq.mt.)	Deductions (Area in Sq.mt.)	Proposed FAR Area (Sq.mt.)	Total FAR Area (Sq.mt.)	Total Consumed Additional FAR Area (Sq.mt.)	Tnmt (No.)
Ground Floor	81.94	16.62	65.32	65.32	65.32	01
First Floor	81.94	0.00	81.94	81.94	81.94	00
Terrace Floor	0.00	0.00	0.00	0.00	0.00	00
Total :	163.88	16.62	147.26	147.26	147.26	01
Total Number of Same Buildings :	1					
Total :	163.88	16.62	147.26	147.26	147.26	01

LTP NAME AND SIGNATURE
RAM PRATAP SINGH
MADA/ARC/0024/2019

STRUCTURAL ENG'S NAME AND SIGNATURE

BUILDER NAME AND SIGNATURE

DIGITAL SIGNATURE

Proposal Basic Information	
Proposal File No.	MADA/BP/0185/2021
Owner Name	SMT. NIRMALA PANDEY
Khata No	OLD KHATA NO-16, NEW KHATA NO-14
Plot No	OLD PLOT NO. 71, NEW PLOT NO. 196
Village Name	Tilakraydih
Use	Residential
SubUse	Bungalow/ Dwelling / Non Apartment

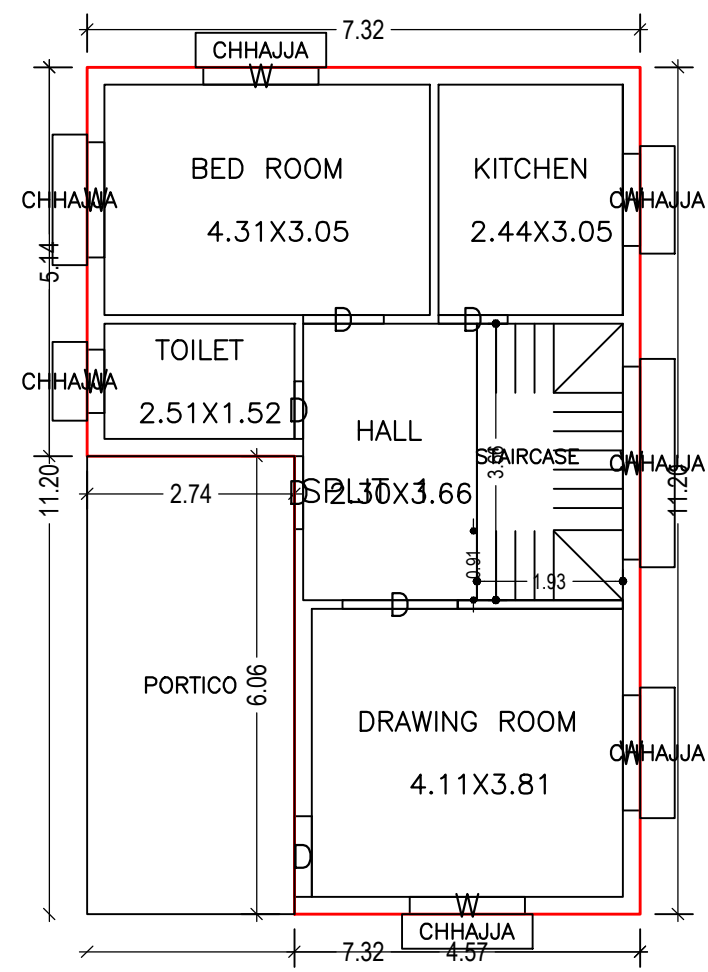

GROUND FLOOR PLAN
(Proposed)
(SCALE 1:100)

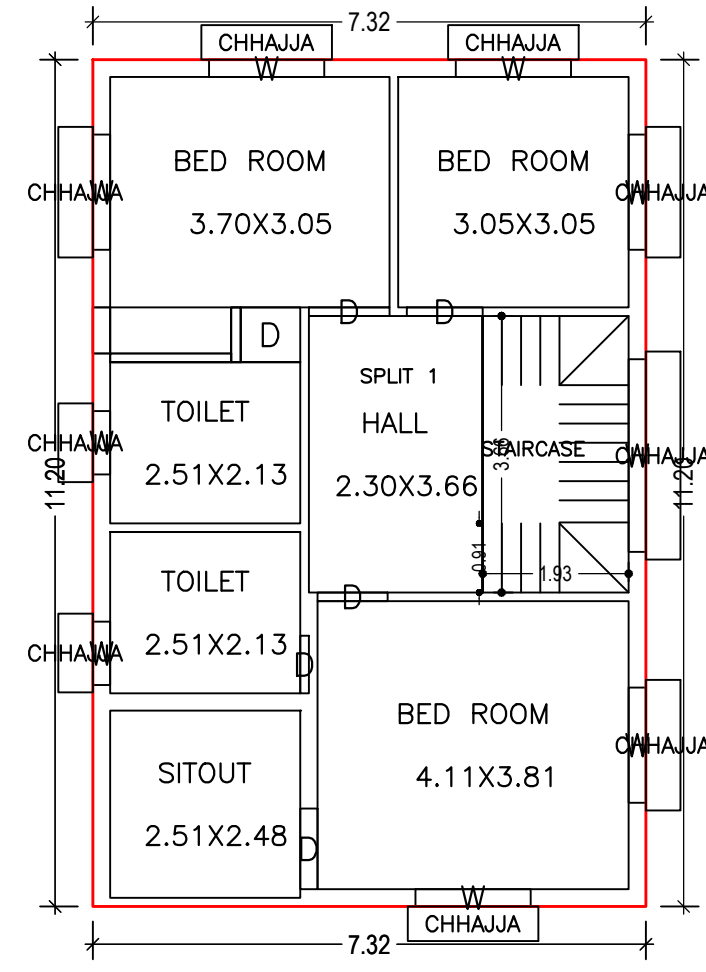

FIRST FLOOR PLAN
(Proposed)
(SCALE 1:100)

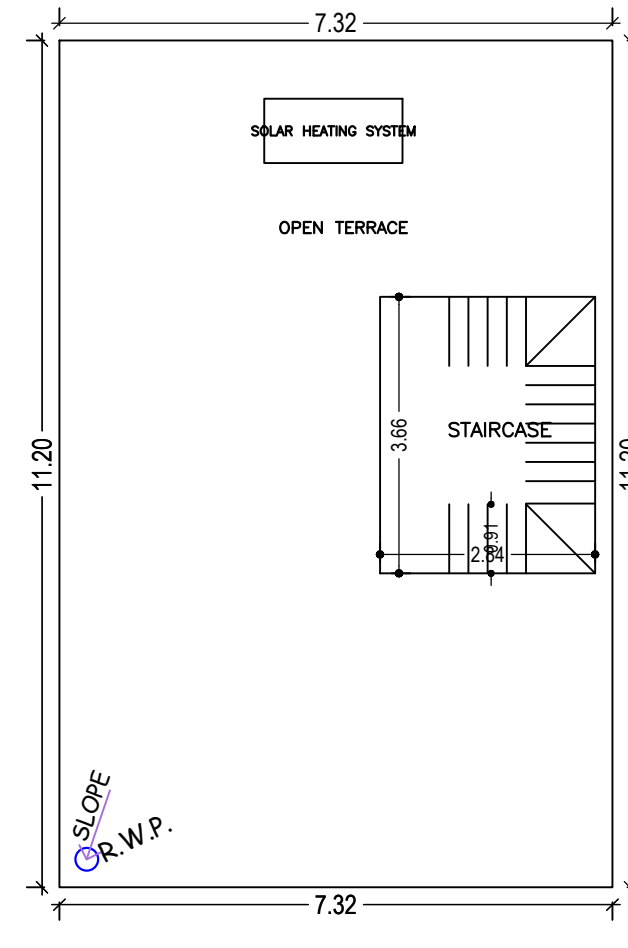

TERRACE FLOOR PLAN
(SCALE 1:100)

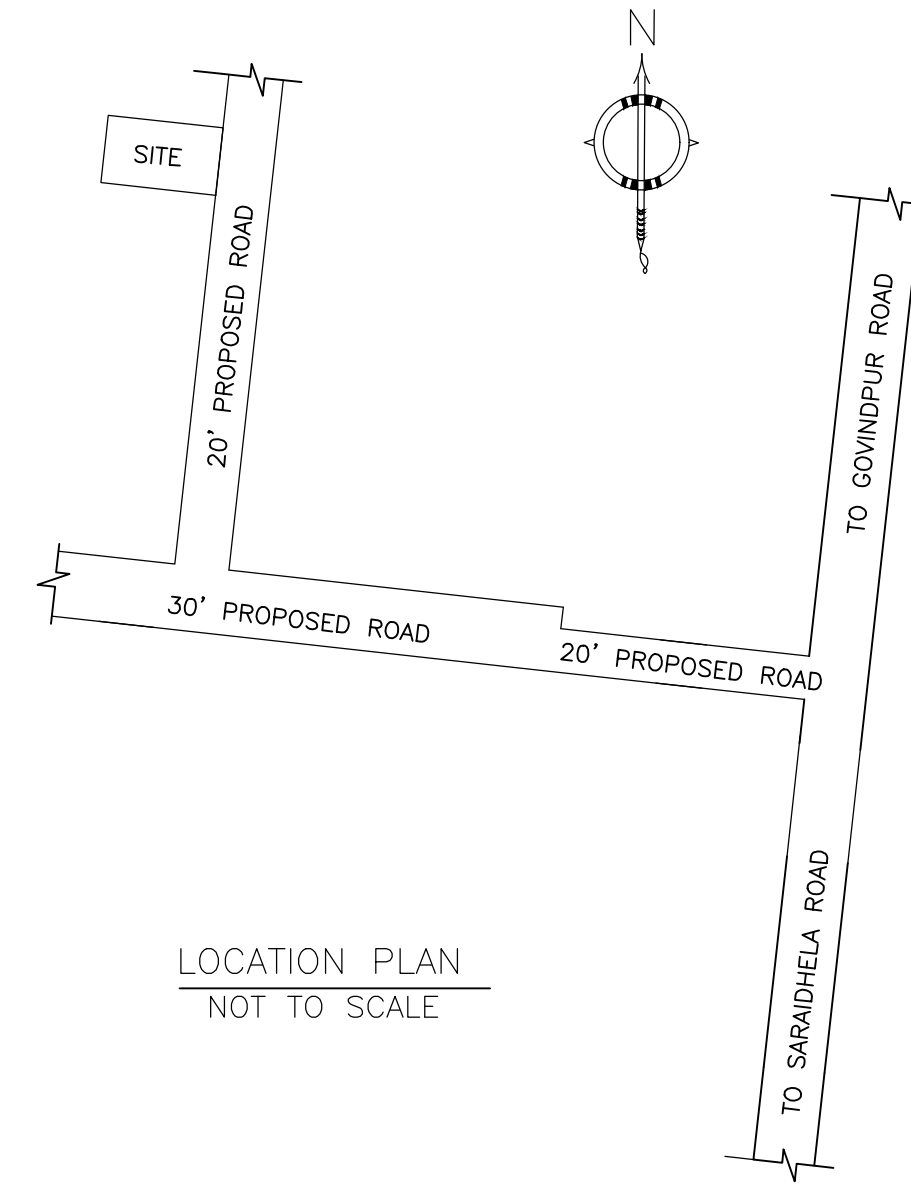

LOCATION PLAN
NOT TO SCALE

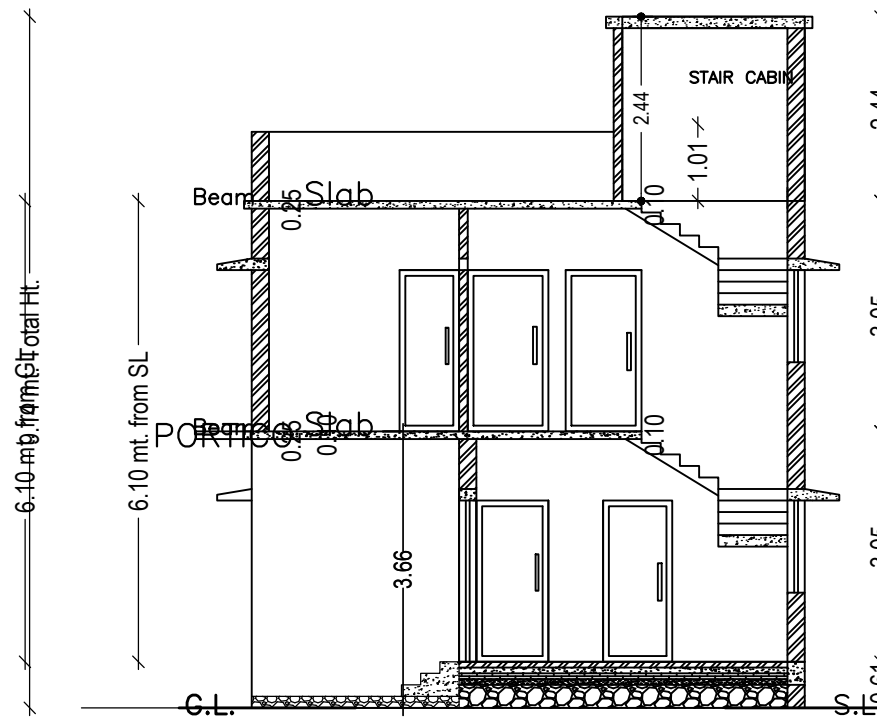
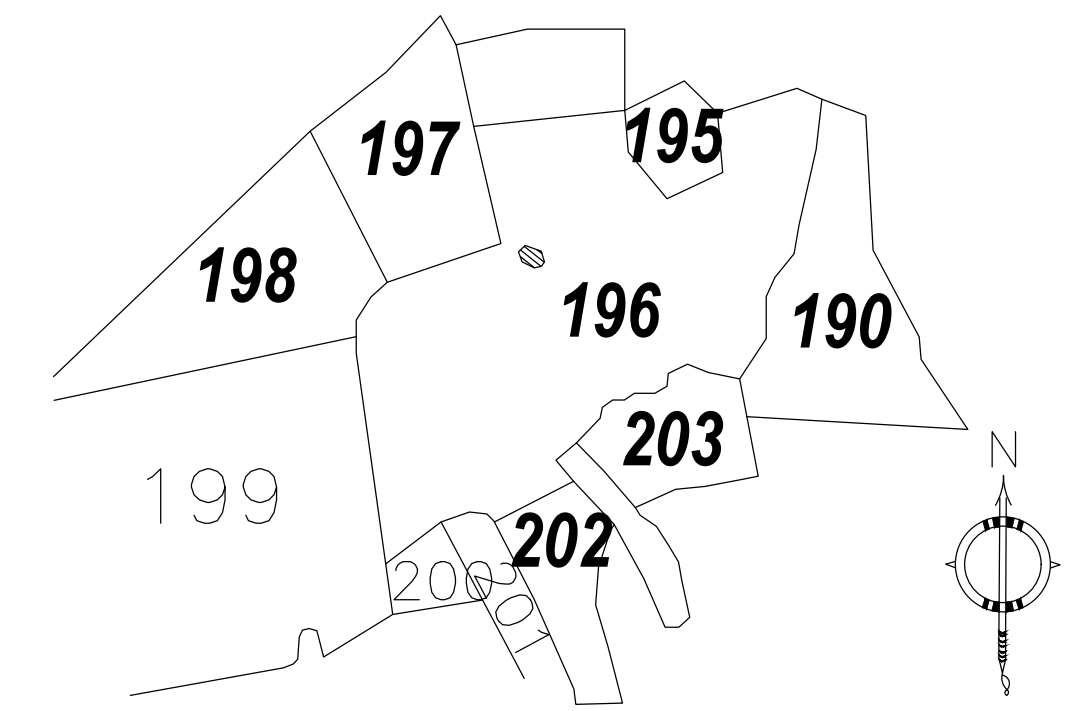

SECTION - XX'
SCALE - 1" = 8'-0"

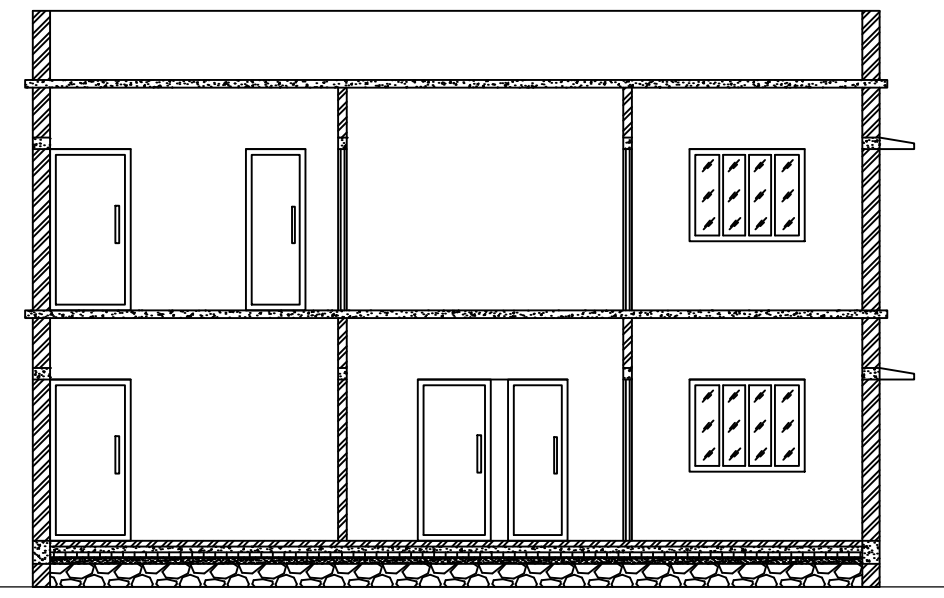

SECTION - YY'
SCALE - 1" = 8'-0"

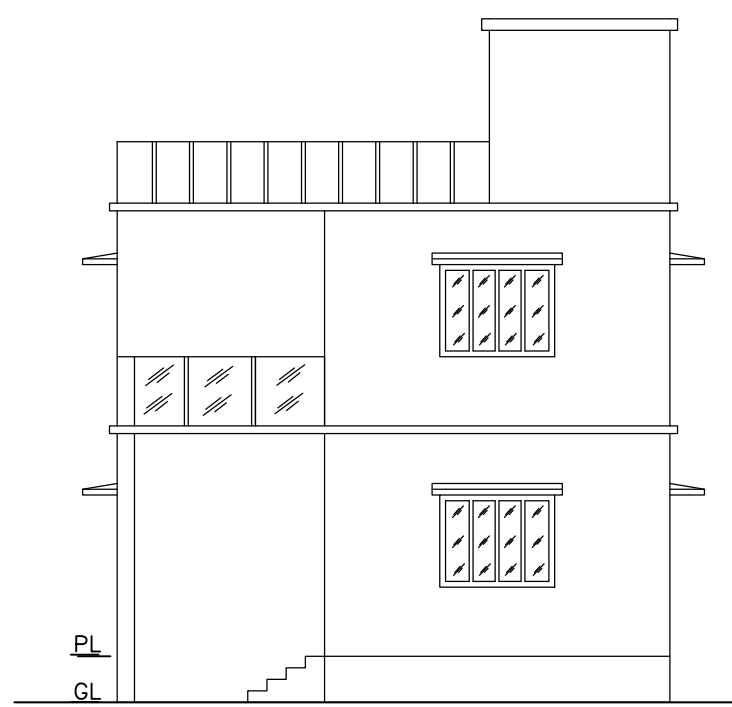

FRONT ELEVATION
SCALE - 1" = 8'-0"

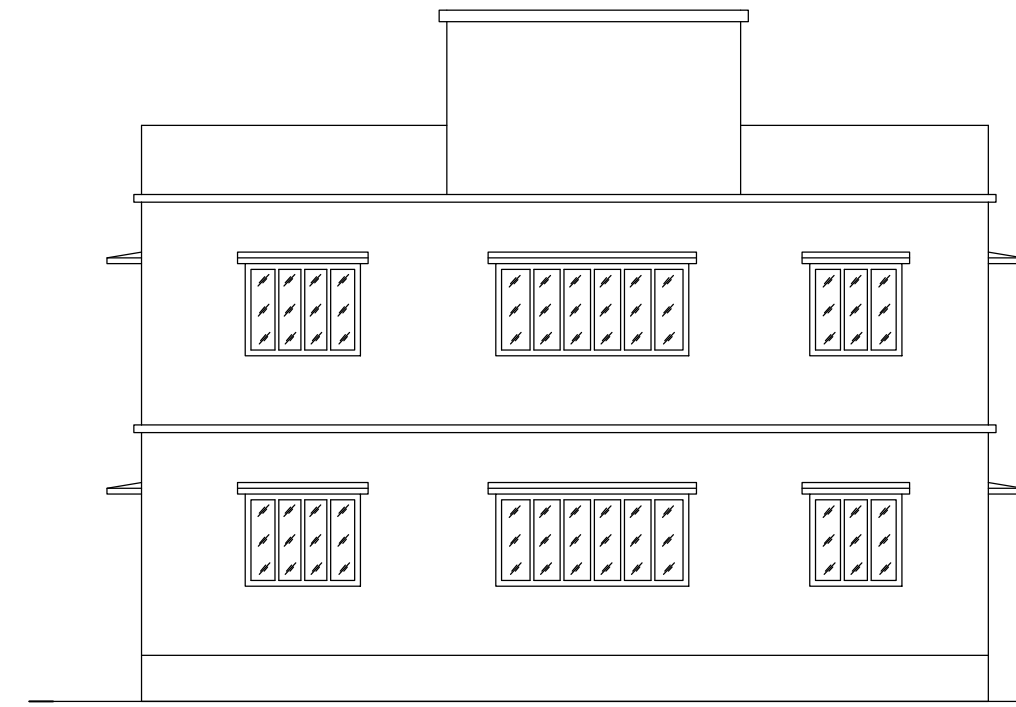

RIGHT SIDE ELEVATION
SCALE - 1" = 8'-0"

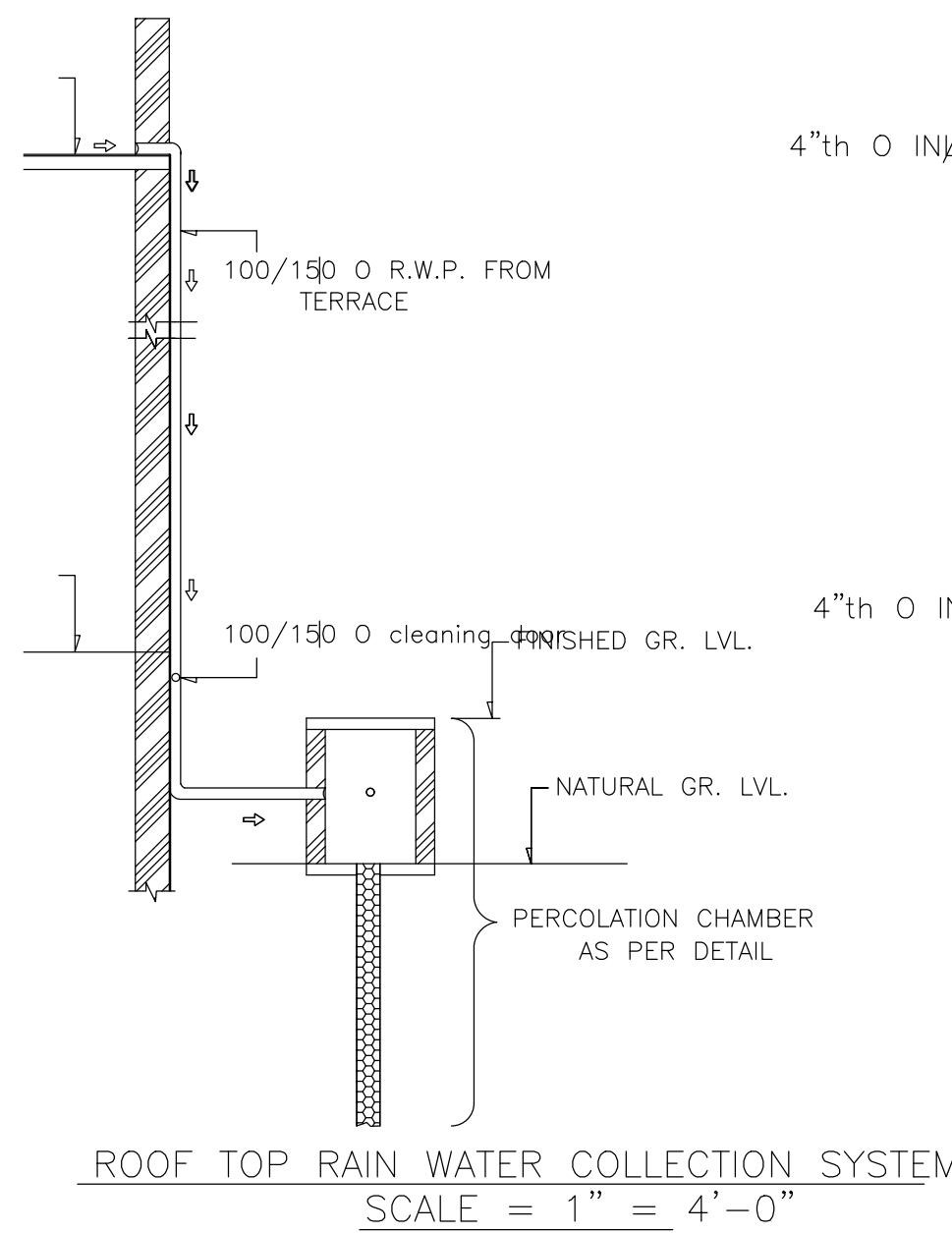

ROOF TOP RAIN WATER COLLECTION SYSTEM
SCALE = 1" = 4'-0"

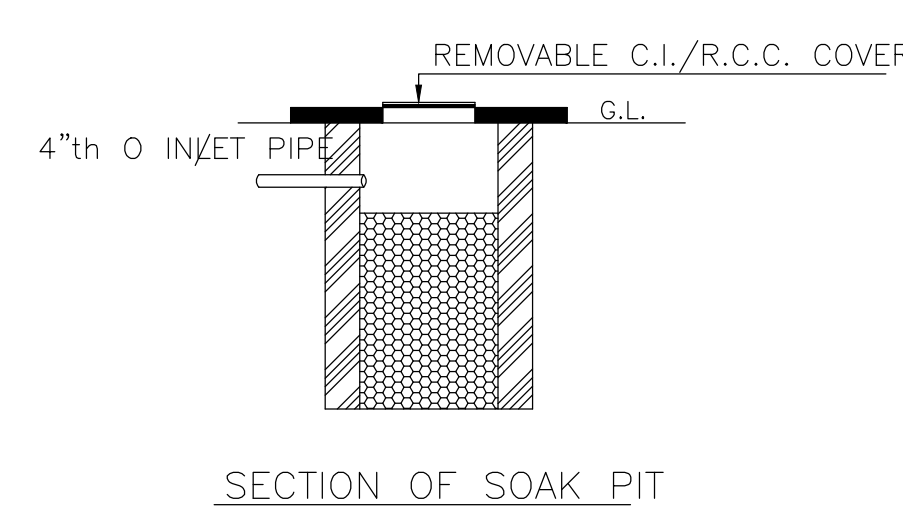

SECTION OF SOAK PIT

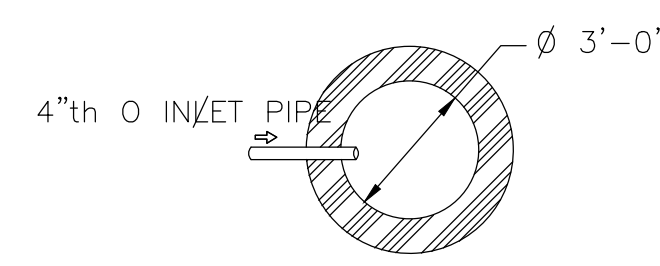

DETAILS OF SOAK PIT
SCALE = 1" = 2'-0"

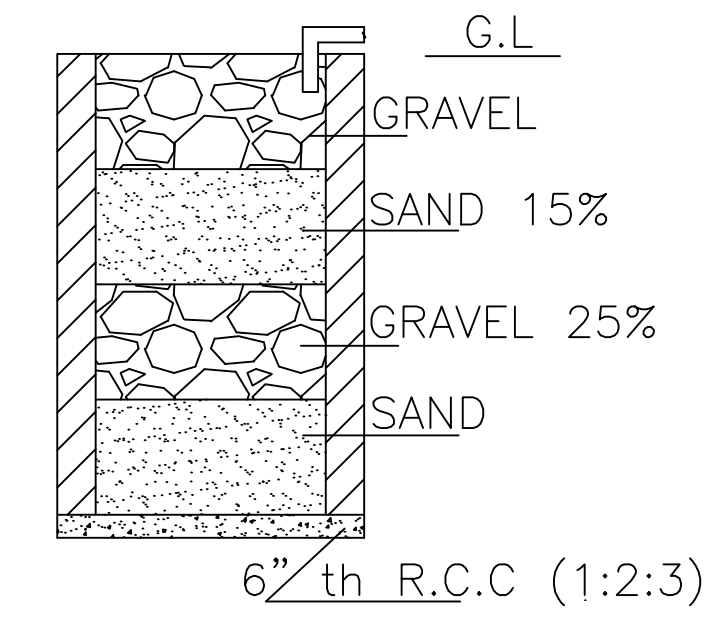

SECTION ON A - B

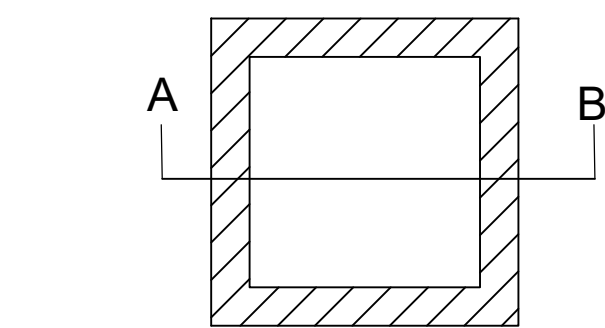

DETAILS DRAWING OF
RAIN WATER HARVESTING

SCALE:- 1"=2'-0"

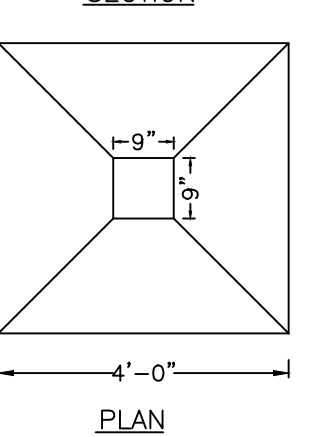
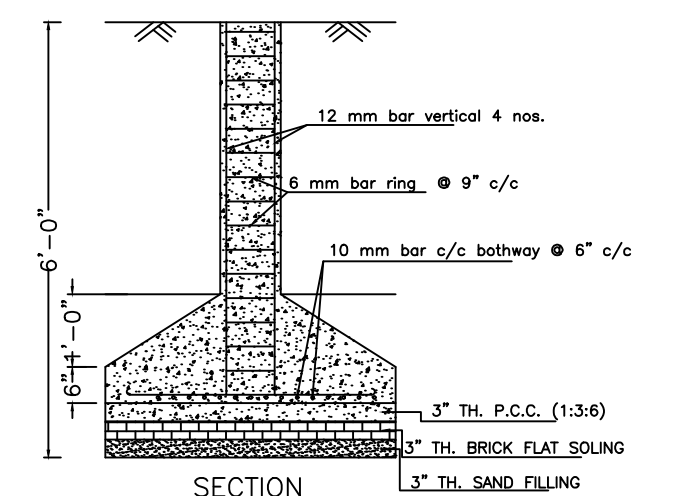

DETAILS OF COLUMN FOUNDATION
SCALE - 1" = 2'-0"

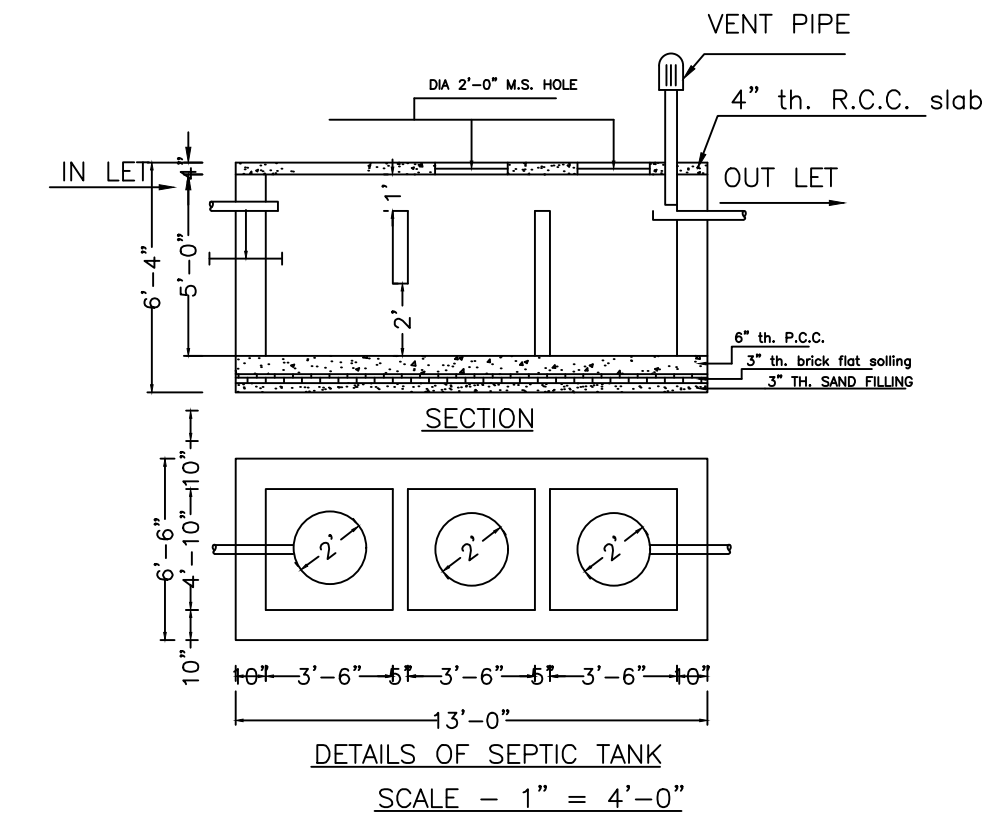

DETAILS OF SEPTIC TANK
SCALE - 1" = 4'-0"

LTP NAME AND SIGNATURE	STRUCTURAL ENG'S NAME AND SIGNATURE	BUILDER NAME AND SIGNATURE	DIGITAL SIGNATURE
RAM PRATAP SINGH MADA/ARC/0024/2019			