

SCHEDULE OF DOOR:

BUILDING NAME	NAME	LENGTH	HEIGHT	NOS
A (SURAJ KR)	D	0.76	2.10	02
A (SURAJ KR)	D	0.79	2.10	01
A (SURAJ KR)	D	0.91	2.10	01
A (SURAJ KR)	D	0.93	2.10	01
A (SURAJ KR)	D	0.97	2.10	01
A (SURAJ KR)	D	1.00	2.10	01
A (SURAJ KR)	D	1.07	2.10	04
A (SURAJ KR)	D	1.52	2.10	01

SCHEDULE OF WINDOW/VENTILATION:

BUILDING NAME	NAME	LENGTH	HEIGHT	NOS
A (SURAJ KR)	W	0.84	1.20	03
A (SURAJ KR)	W	1.22	1.20	01
A (SURAJ KR)	W	1.52	1.20	10
A (SURAJ KR)	W	2.55	1.20	02

UnitBUA Table for Building :A (SURAJ KR)

FLOOR	Name	UnitBUA Type	UnitBUA Area	Carpet Area	No. of Rooms	No. of Tenement
GROUND FLOOR PLAN	SPLIT 1	FLAT	147.26	146.60	5	1
FIRST FLOOR PLAN	SPLIT 1	FLAT	0.00	0.00	7	0
Total:	-	-	147.26	146.60	12	1

FAR & Tenement Details (Table 4c-1)

Building	No. of Same Bldg	Total Built Up Area (Sq.mt.)	Deductions (Area in Sq.mt.)		Proposed FAR Area (Sq.mt.)	Total FAR Area (Sq.mt.)	Total Consumed Additional FAR Area (Sq.mt.)	Trmt (No.)
			Archi.Proj.	Resi.				
A (SURAJ KR)	1	163.88	16.62	147.26	147.26	147.26	01	
Grand Total:	1	163.88	16.62	147.26	147.26	147.26	01	

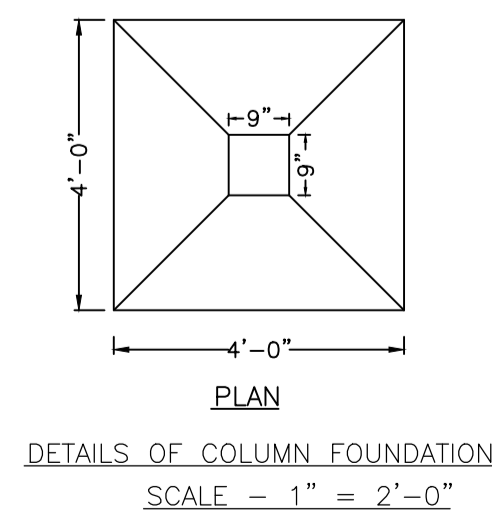

Proposal Basic Information

Proposal File No.	MADA/BP/0202/2021
Owner Name	SRI. SURAJ KUMAR
Khata No	OLD KHATA NO-16, NEW KHATA NO-14
Plot No	OLD PLOT NO. 71, NEW PLOT NO. 196
Village Name	Tiakraydih
Use	Residential
SubUse	Bungalow/ Dwelling / Non Apartment

AREA STATEMENT MINERAL AREA DEVELOPMENT AUTHORITY

VERSION NO.: 1.0.60
VERSION DATE: 16/10/2020

Region:	Plot Use:
JHARKHAND URBAN LOCAL BODIES	Residential
District: DHANBAD	Plot SubUse: Bungalow/ Dwelling / Non Apartment
Authority: MINERAL AREA DEVELOPMENT AUTHORITY	PlotNearby/ReligiousStructure: NA
Inward No: MADA/BP/0202/2021	Plot/SubPlot No: OLD PLOT NO. 71, NEW PLOT NO. 196
Application Type: General Proposal	North: Plot No. - SAME PLOT
Project Type: Building Permission	South: Plot No. - SAME PLOT
Nature of Development: New	East: Plot No. - SAME PLOT
Location of Development Area: Old Area	West: Road Width - 6.10

AREA DETAILS:

AREA OF PLOT (Minimum)	(A)	SQ.MT.
NET AREA OF PLOT(Gross Plot Area - Deduction from Gross Plot area)	(A-Deductions)	138.76
Deduction for Balance Plot Area(from Gross Plot Area)		
Common Plot		14.07
Total		14.07
BALANCE AREA OF PLOT(Net Plot Area - Recreational/Amenity space)	(A-Deductions)	124.69
PLOT AREA FOR COVERAGE(Net Plot Area)	(A-Deductions)	138.76
Plot Area for FAR (Net Plot Area + RoadWidening Area)	(A-Deductions)	138.76

COVERAGE CHECK

Permissible Coverage area (70.00 %)	97.13
Proposed Coverage Area (47.08 %)	65.32
Total Prop. Coverage Area (47.08 %)	65.32
Balance coverage area (22.93 %)	31.81

FAR CHECK

Perm. FAR Area (2.50)	346.90
Total Perm. FAR area	346.90
Residential FAR	147.26
Proposed FAR Area	147.26
Total Proposed FAR Area	147.26
Consumed FAR (Factor)	1.06
Balance FAR Area	199.64

BUILT UP AREA CHECK

Total Proposed BuiltUp Area	163.88
ARCHITECT (Regd)	RAM PRATAP SINGH
ENGINEER (Regd)	
SUPERVISOR (Regd)	
OWNER (Regd)	SRI. SURAJ KUMAR
DEVELOPMENT AUTHORITY	LOCAL BODY

COLOR INDEX

PLOT BOUNDARY	Black
ABUTTING ROAD	Green
PROPOSED CONSTRUCTION	Red
COMMON PLOT	Yellow
ROAD WIDENING AREA	Blue
EXISTING (To be retained)	Orange
EXISTING (To be demolished)	Light Blue

Buildingwise Floor FAR Details

Floor Name	Building Name		Total	
	Proposed Built Up Area (Sq.mt.)	Proposed FAR Area (Sq.mt.)	Total Proposed Built Up Area (Sq.mt.)	Total FAR Area (Sq.mt.)
Ground Floor	81.94	65.32	81.94	65.32
First Floor	81.94	81.94	81.94	81.94
Terrace Floor	0.00	0.00	0.00	0.00
Total :	163.88	147.26	163.88	147.26

Building USE/SUBUSE Details

Building Name	Building Use	Building SubUse	Building Structure
A (SURAJ KR)	Residential	Bungalow/ Dwelling / Non Apartment	Non-Highrise

Building :A (SURAJ KR)

Floor Name	Total Built Up Area (Sq.mt.)	Deductions (Area in Sq.mt.)		Proposed FAR Area (Sq.mt.)	Total FAR Area (Sq.mt.)	Total Consumed Additional FAR Area (Sq.mt.)	Trmt (No.)
		Archi.Proj.	Resi.				
Ground Floor	81.94	16.62	65.32	65.32	65.32	65.32	01
First Floor	81.94	0.00	81.94	81.94	81.94	81.94	00
Terrace Floor	0.00	0.00	0.00	0.00	0.00	0.00	00
Total :	163.88	16.62	147.26	147.26	147.26	147.26	01
Total Number of Same Buildings	1						
Total :	163.88	16.62	147.26	147.26	147.26	147.26	01

LTP NAME AND SIGNATURE	STRUCTURAL ENG'S NAME AND SIGNATURE	BUILDER NAME AND SIGNATURE	DIGITAL SIGNATURE
RAM PRATAP SINGH MADA/ARC/0024/2019			

Proposal Basic Information	
Proposal File No.	MADA/BP/0202/2021
Owner Name	SRI. SURAJ KUMAR
Khata No	OLD KHATA NO-16, NEW KHATA NO-14
Plot No	OLD PLOT NO. 71, NEW PLOT NO. 196
Village Name	Tiakraydih
Use	Residential
SubUse	Bungalow/ Dwelling / Non Apartment

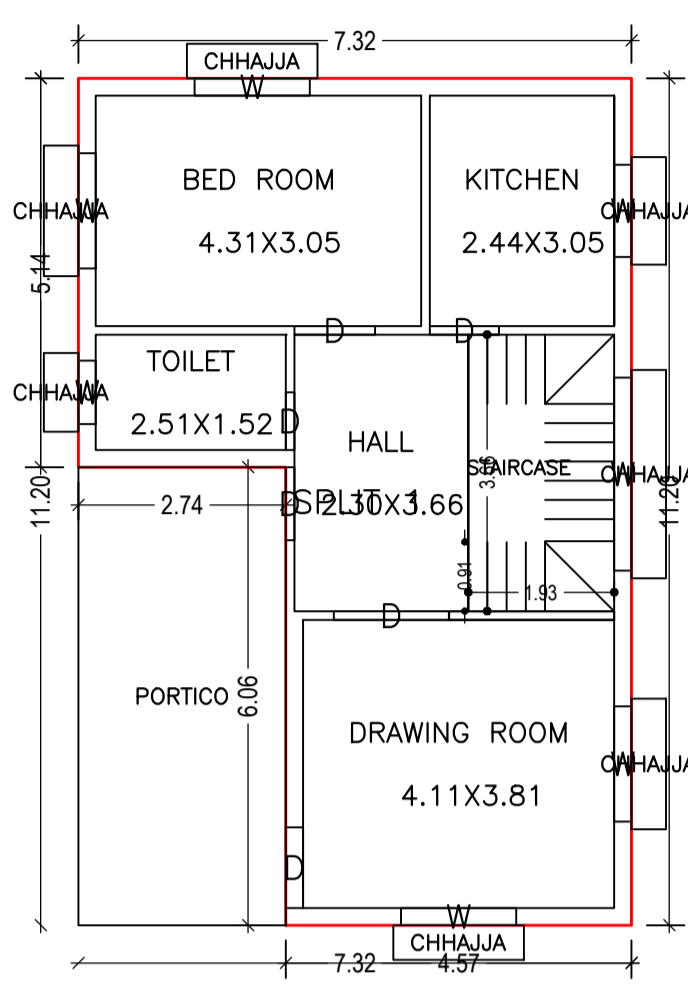

GROUND FLOOR PLAN
(Proposed)
(SCALE 1:100)

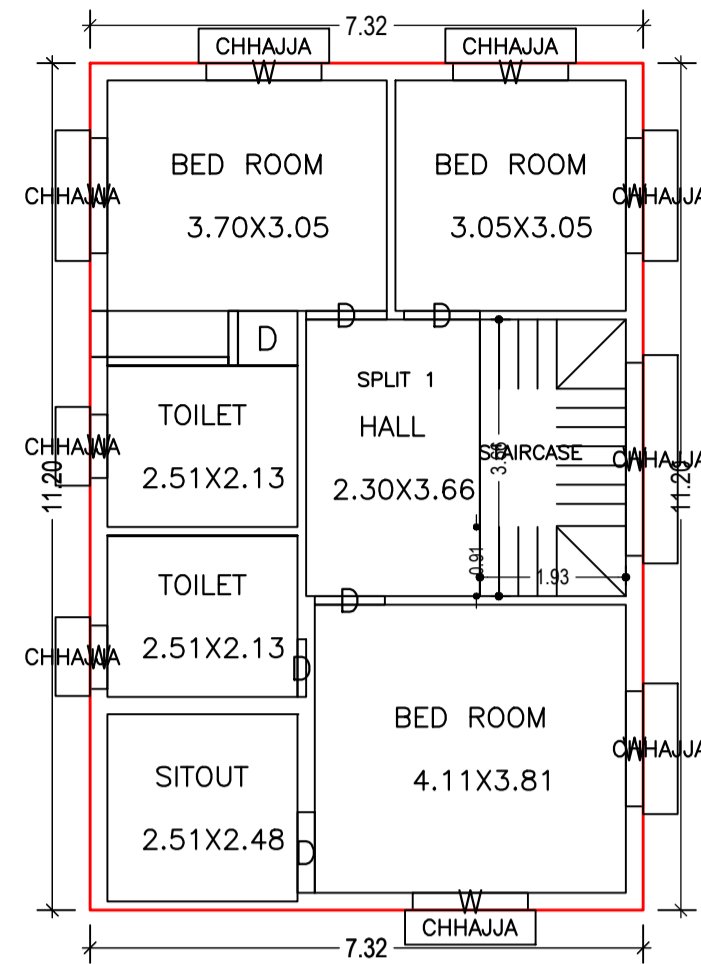

FIRST FLOOR PLAN
(Proposed)
(SCALE 1:100)

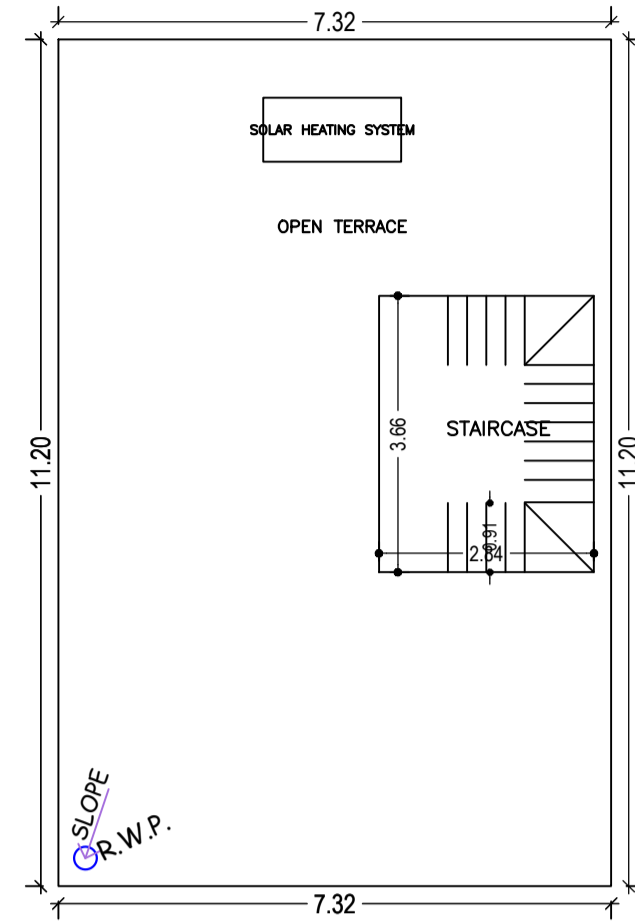

TERRACE FLOOR PLAN
(SCALE 1:100)

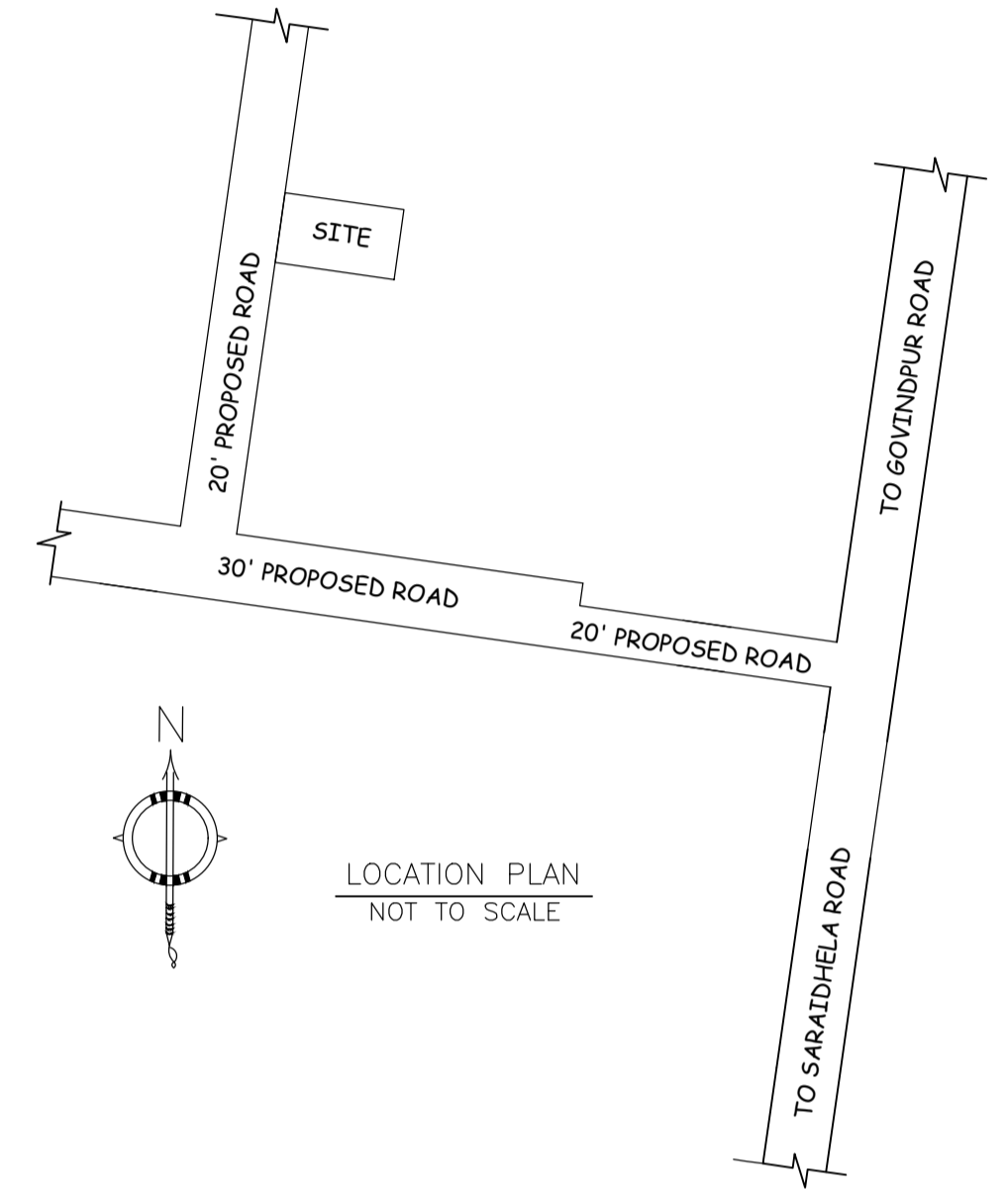
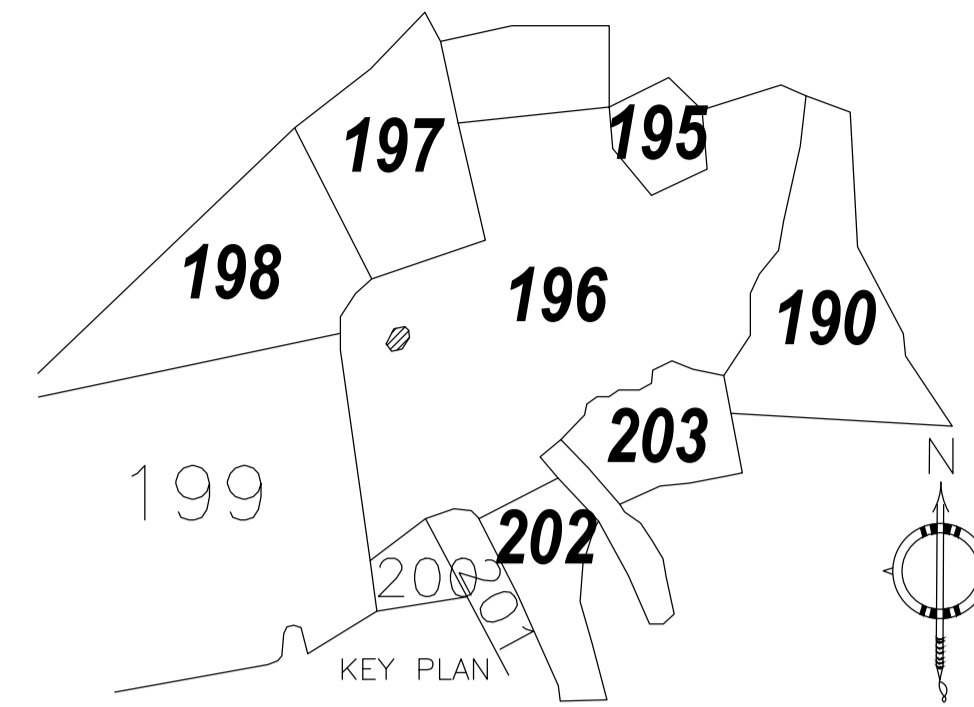

LOCATION PLAN
NOT TO SCALE

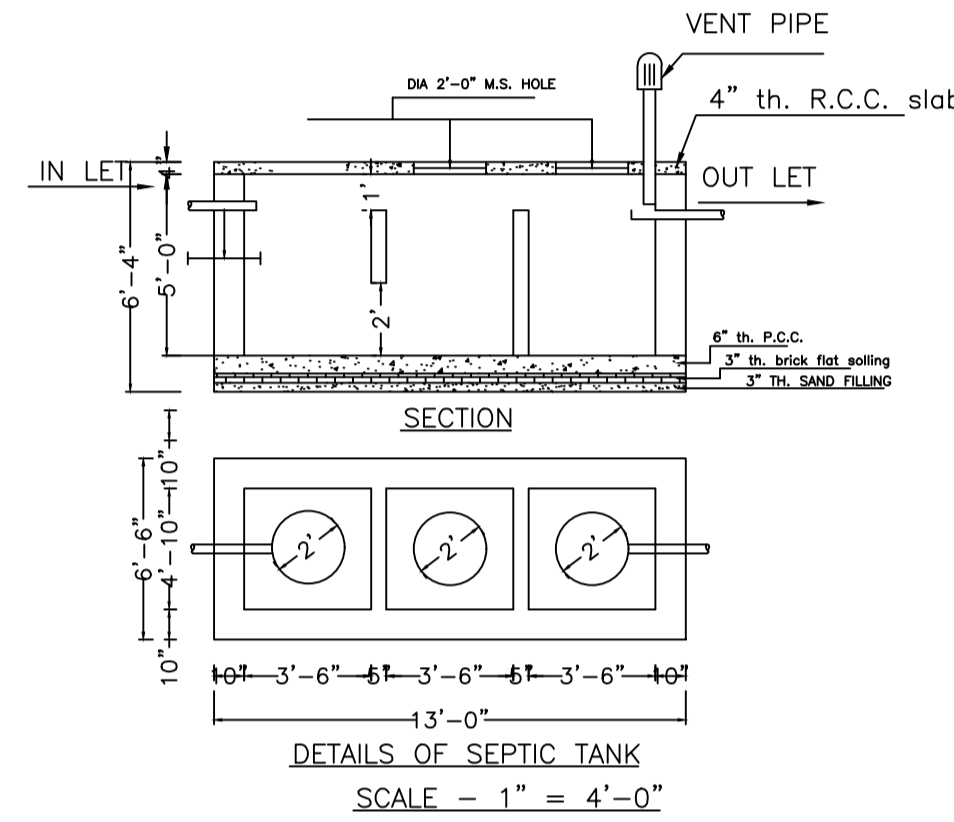

DETAILS OF SEPTIC TANK
SCALE - 1" = 4'-0"

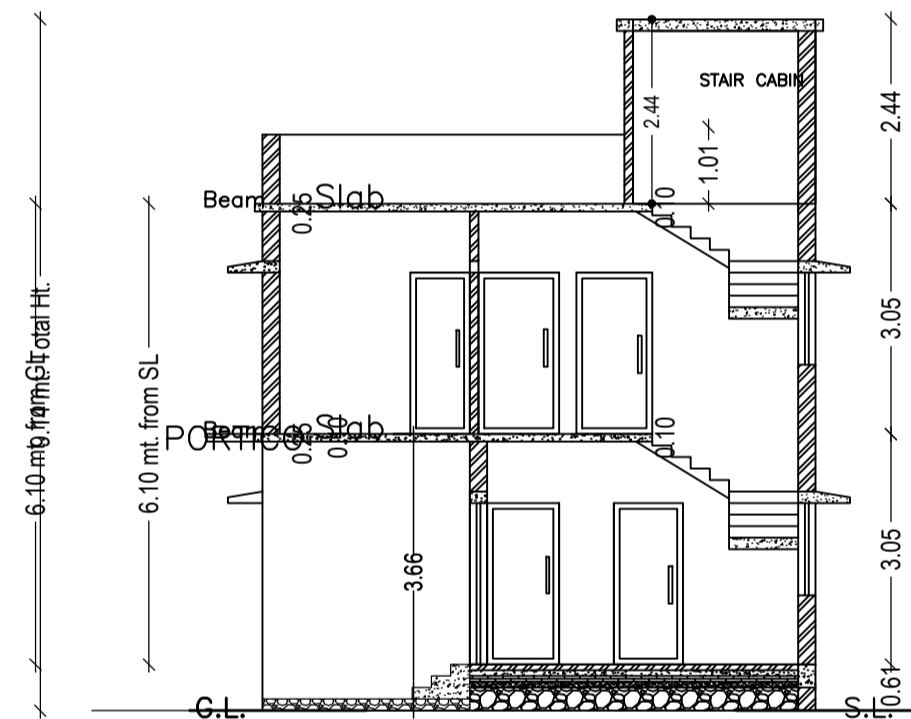

SECTION - XX'
SCALE - 1" = 8'-0"

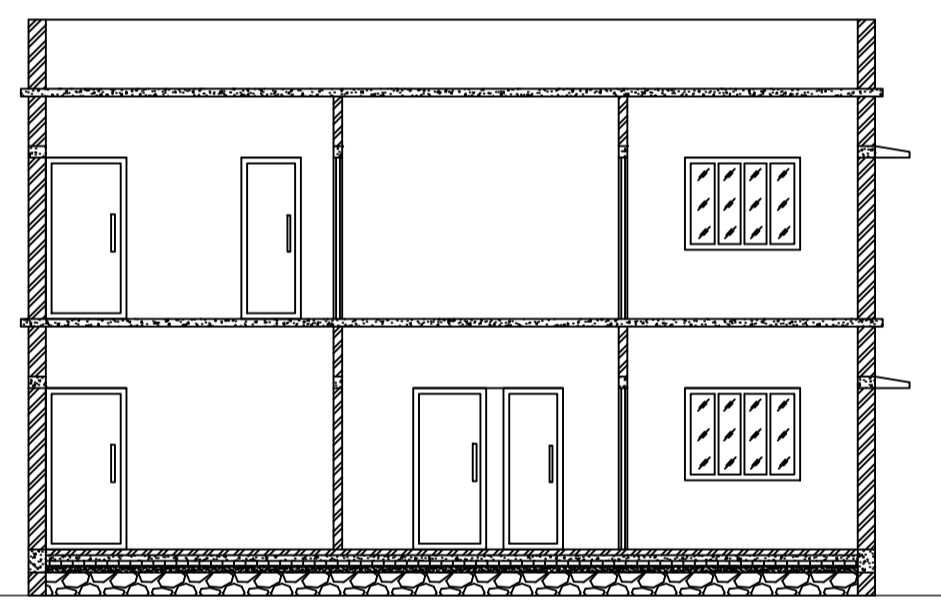

SECTION - YY'
SCALE - 1" = 8'-0"

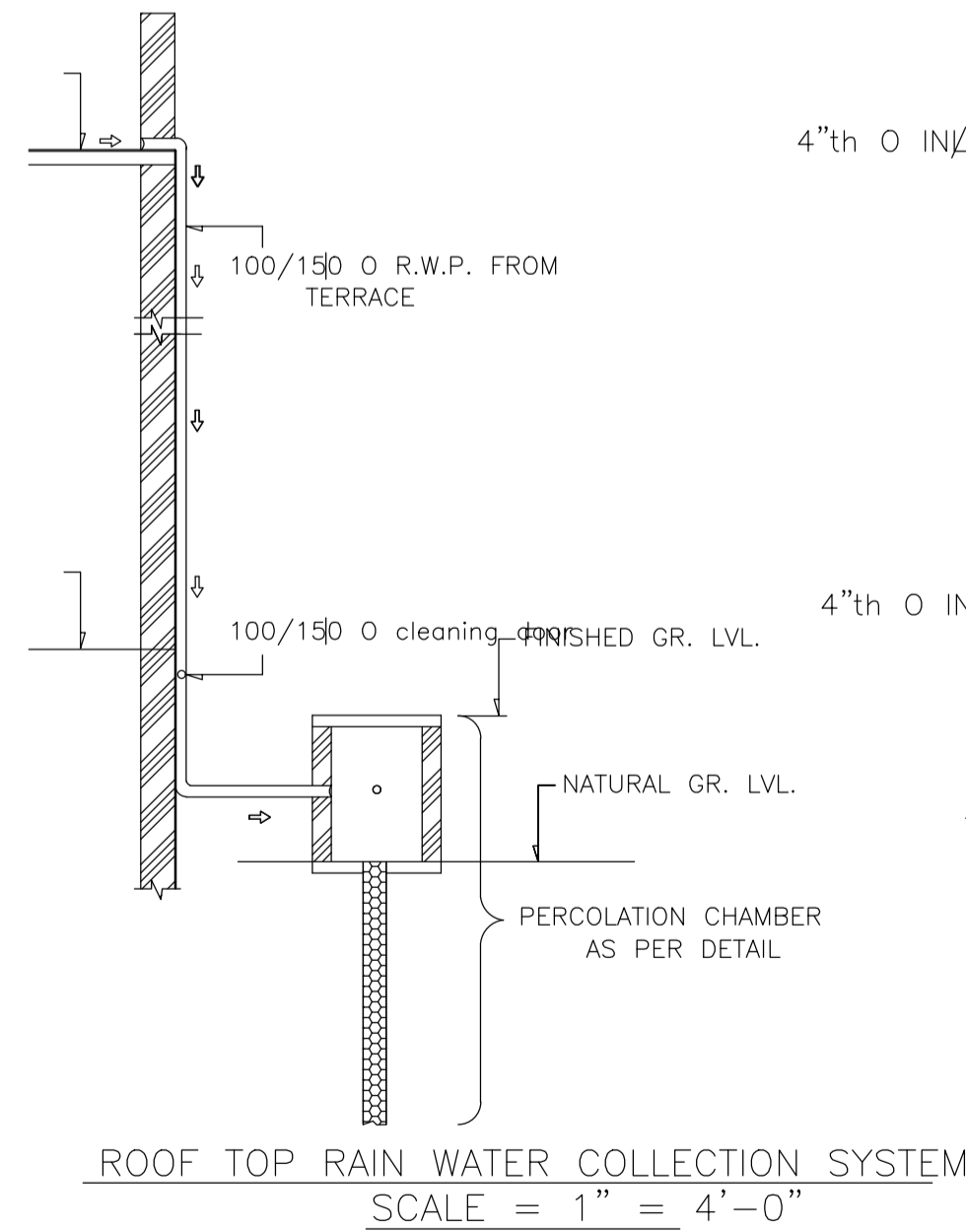

ROOF TOP RAIN WATER COLLECTION SYSTEM
SCALE = 1" = 4'-0"

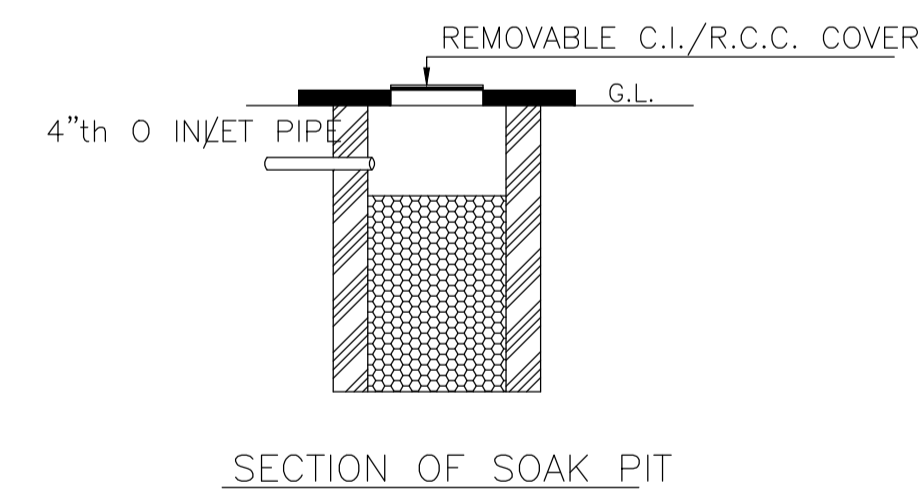

SECTION OF SOAK PIT

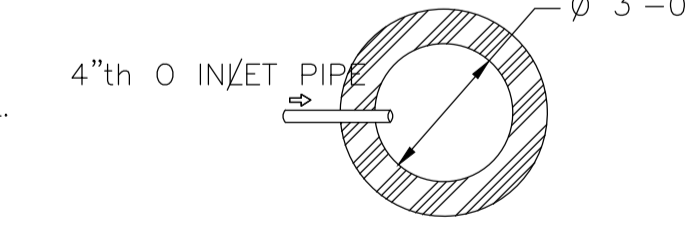

DETAILS OF SOAK PIT
SCALE = 1" = 2'-0"

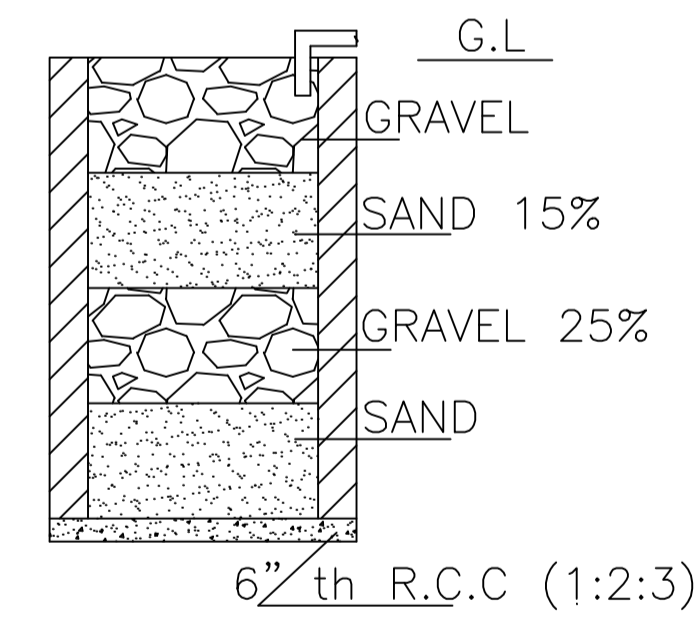

SECTION ON A - B

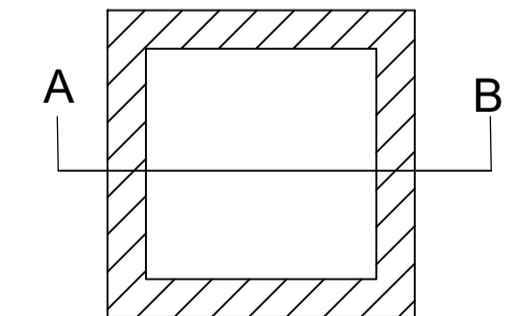

DETAILS DRAWING OF
RAIN WATER HARVESTING
SCALE:- 1"=2'-0"

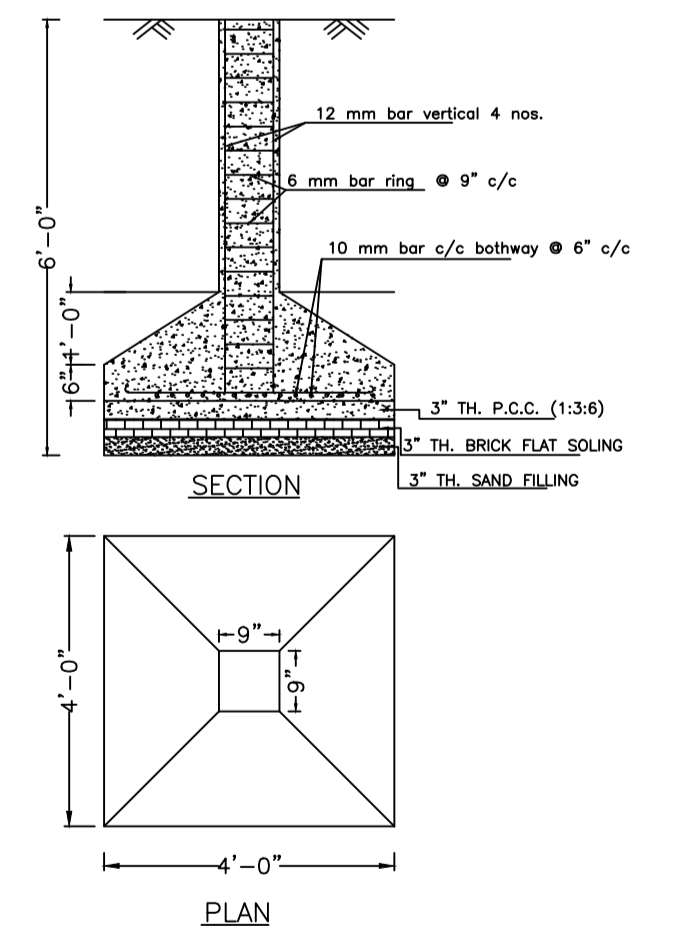

DETAILS OF COLUMN FOUNDATION
SCALE - 1" = 2'-0"

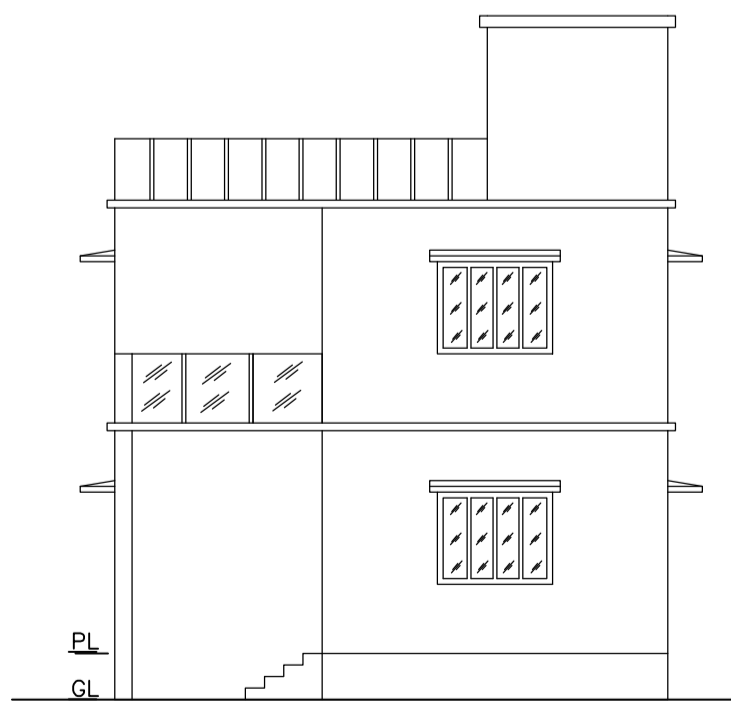

FRONT ELEVATION
SCALE - 1" = 8'-0"

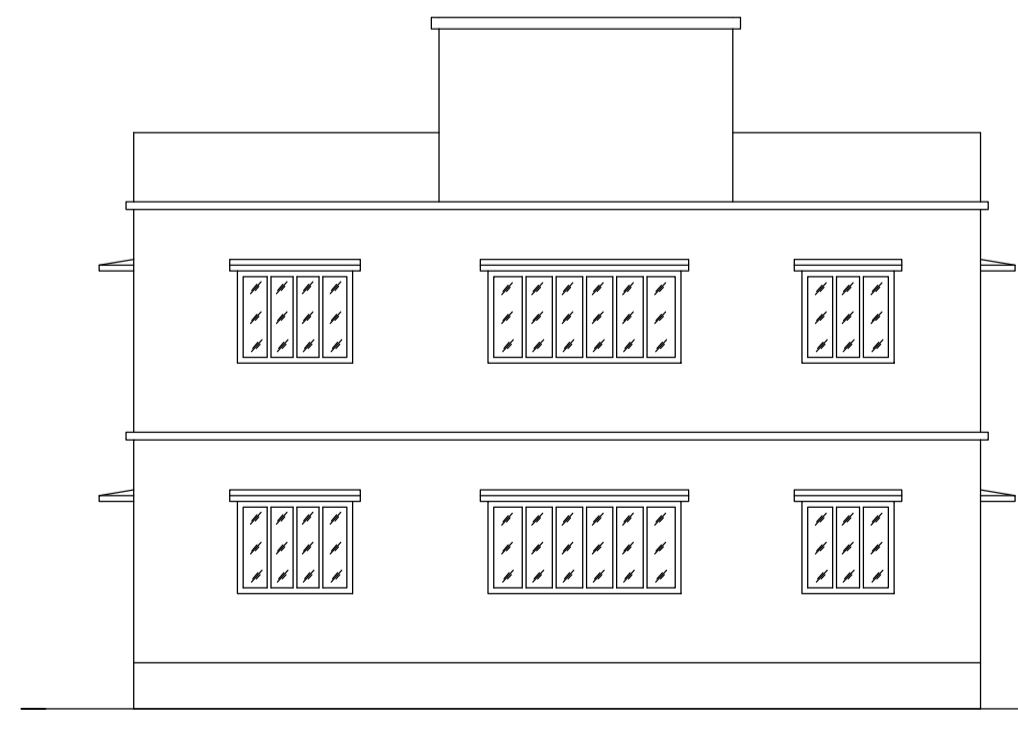

RIGHT SIDE ELEVATION
SCALE - 1" = 8'-0"

LTP NAME AND SIGNATURE	STRUCTURAL ENG'S NAME AND SIGNATURE	BUILDER NAME AND SIGNATURE	DIGITAL SIGNATURE
RAM PRATAP SINGH MADA/ARC/0024/2019			