

DETAIL'S OF WATER HARVESTING

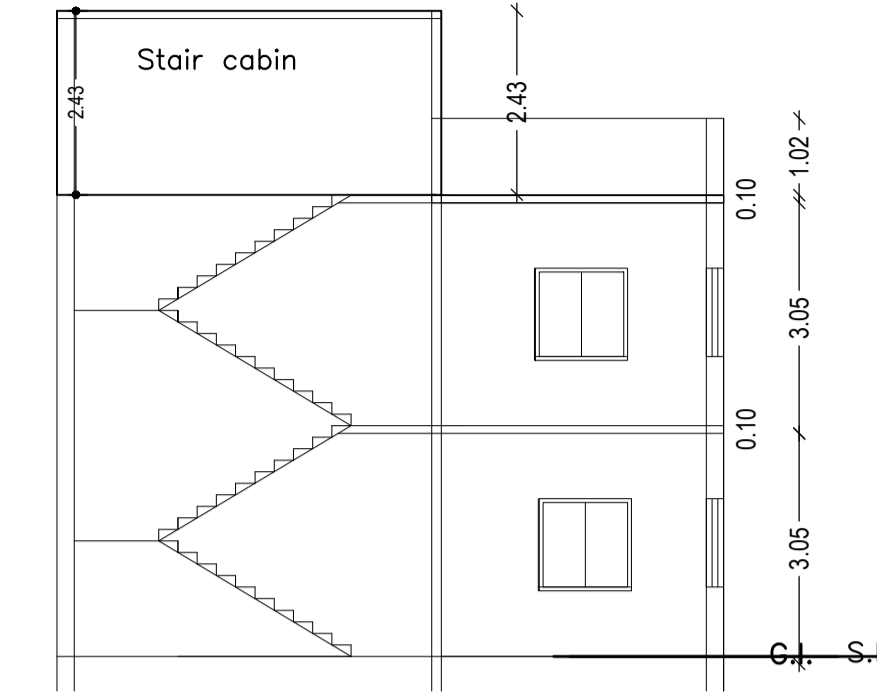

Site plan

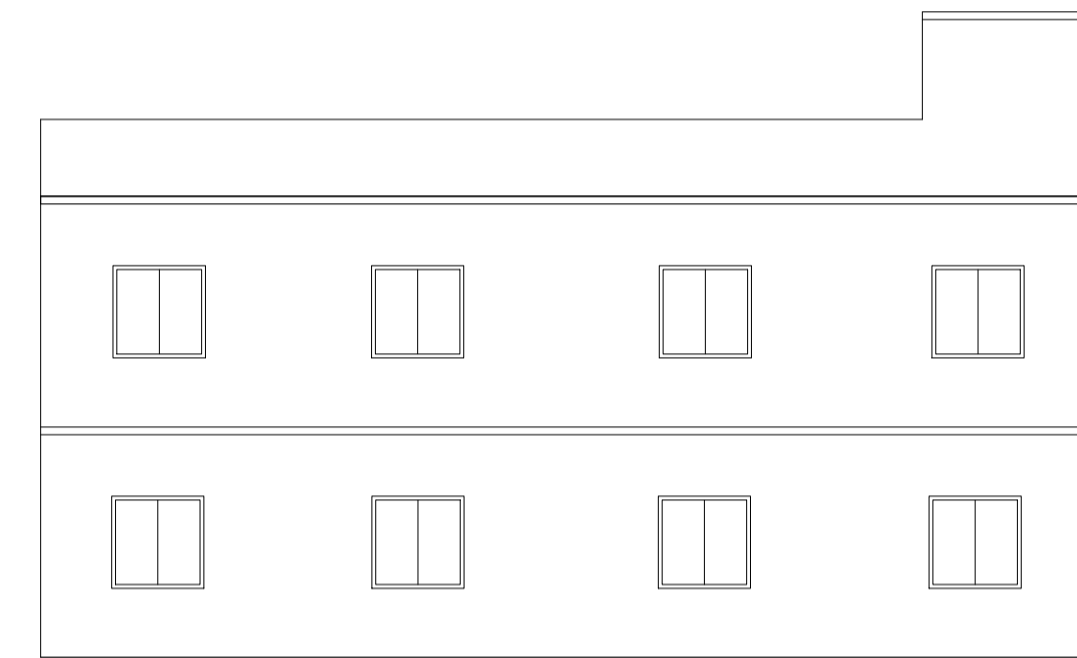
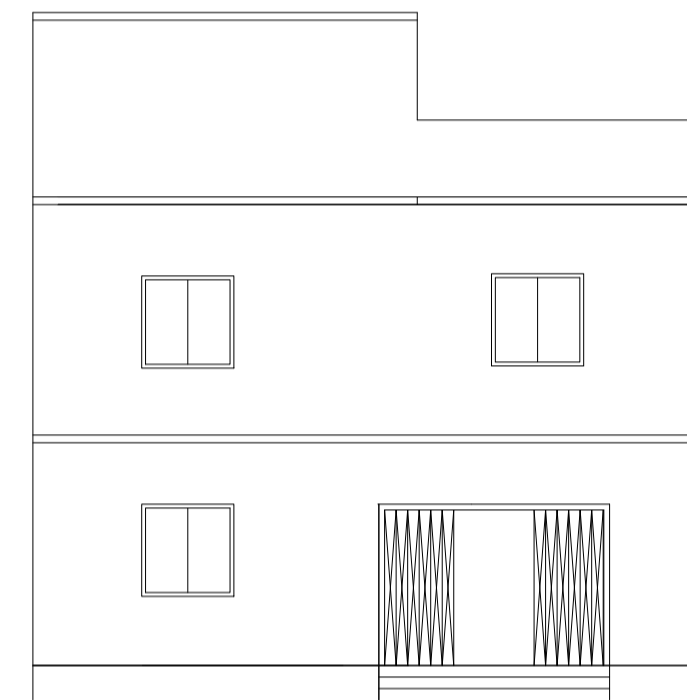
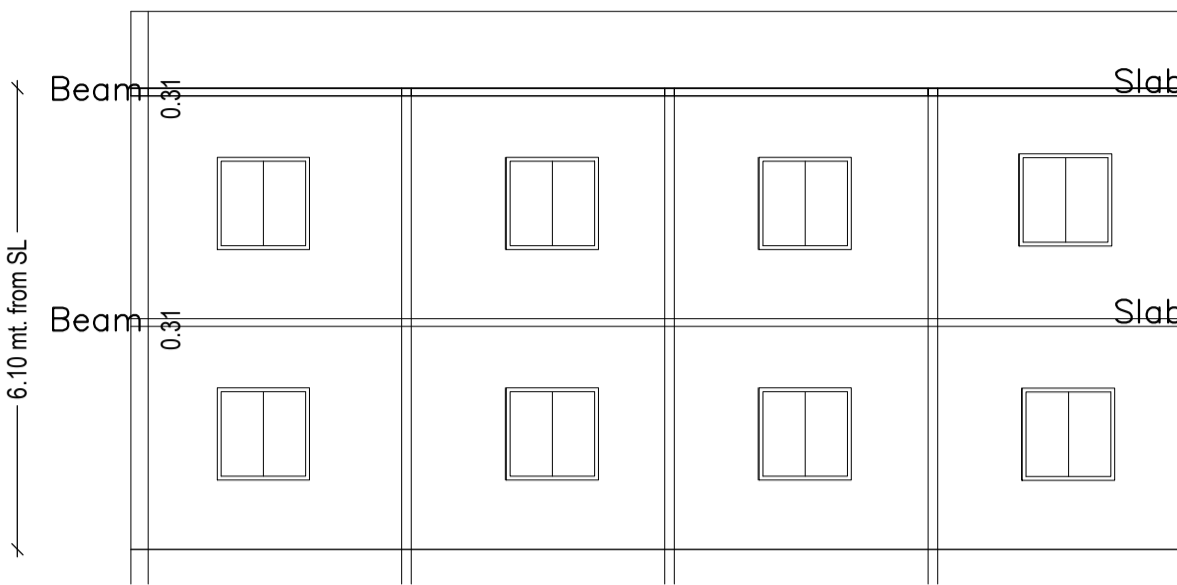
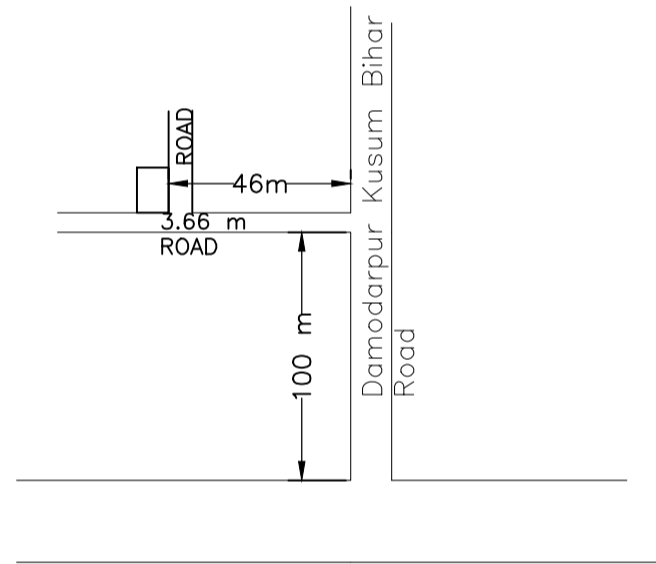
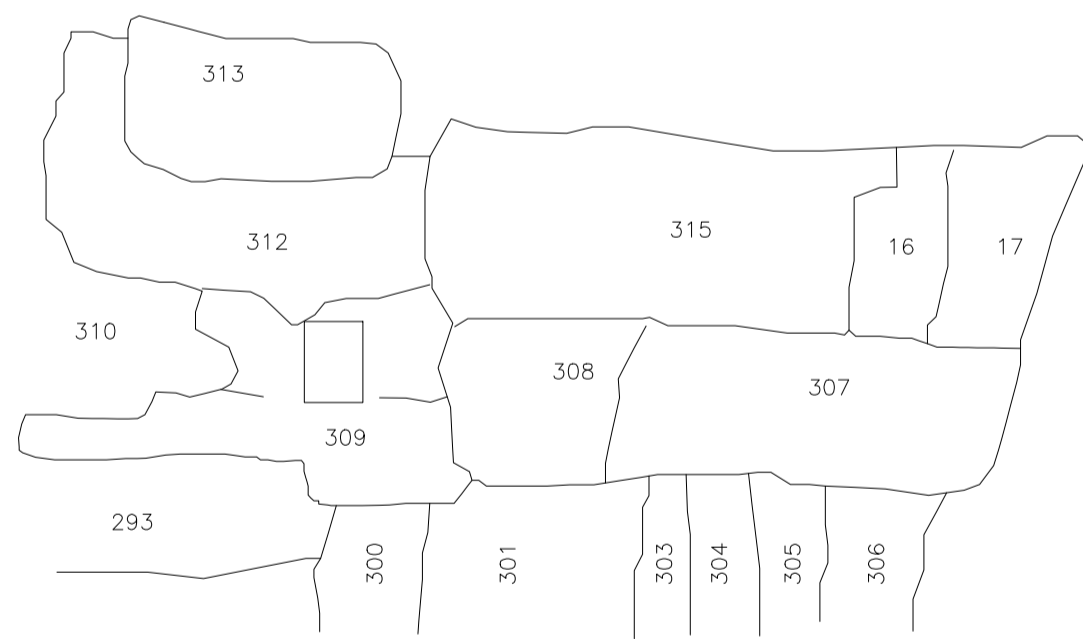

SCHEDULE OF DOOR:

BUILDING NAME	NAME	LENGTH	HEIGHT	NOS
V (1)	d3	0.90	2.10	03
V (1)	d1	1.00	2.10	06
V (1)	d2	1.15	2.10	01
V (1)	C.G.	2.35	2.10	01

SCHEDULE OF WINDOW/VENTILATION:

BUILDING NAME	NAME	LENGTH	HEIGHT	NOS
V (1)	v1	1.00	0.60	03
V (1)	w2	1.15	1.20	01
V (1)	w1	2.20	1.20	17

Building :V (1)

Floor Name	Total Built Up Area (Sq.mt.)	Proposed FAR Area (Sq.mt.) Resi.	Total FAR Area (Sq.mt.)	Total Consumed Additional FAR Area (Sq.mt.)	Tnmt (No.)
Ground Floor	124.71	124.71	124.71	124.71	01
First Floor	124.71	124.71	124.71	124.71	00
Terrace Floor	0.00	0.00	0.00	0.00	00
Total :	249.42	249.42	249.42	249.42	01
Total Number of Same Buildings :	1				
Total :	249.42	249.42	249.42	249.42	01

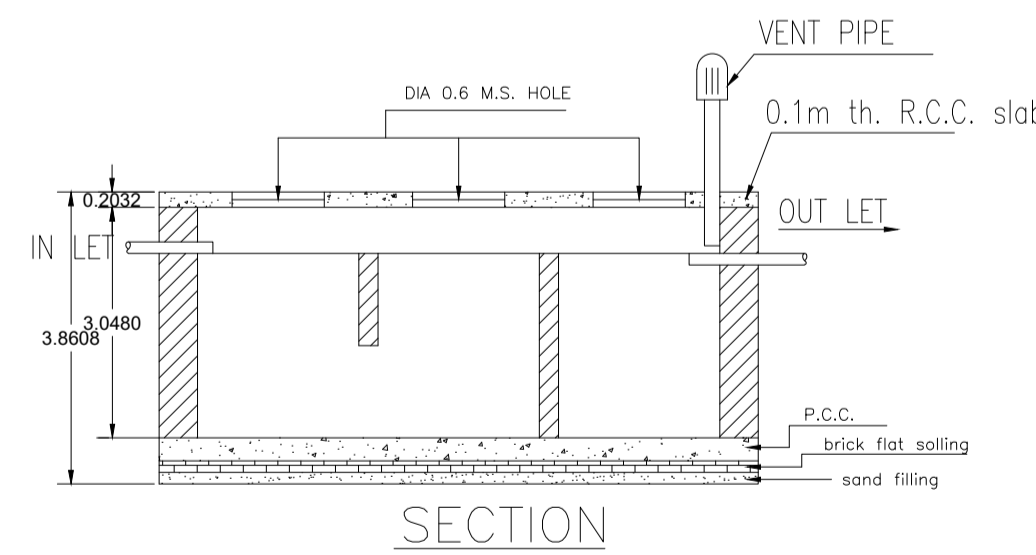

DETAILS OF SEPTIC TANK

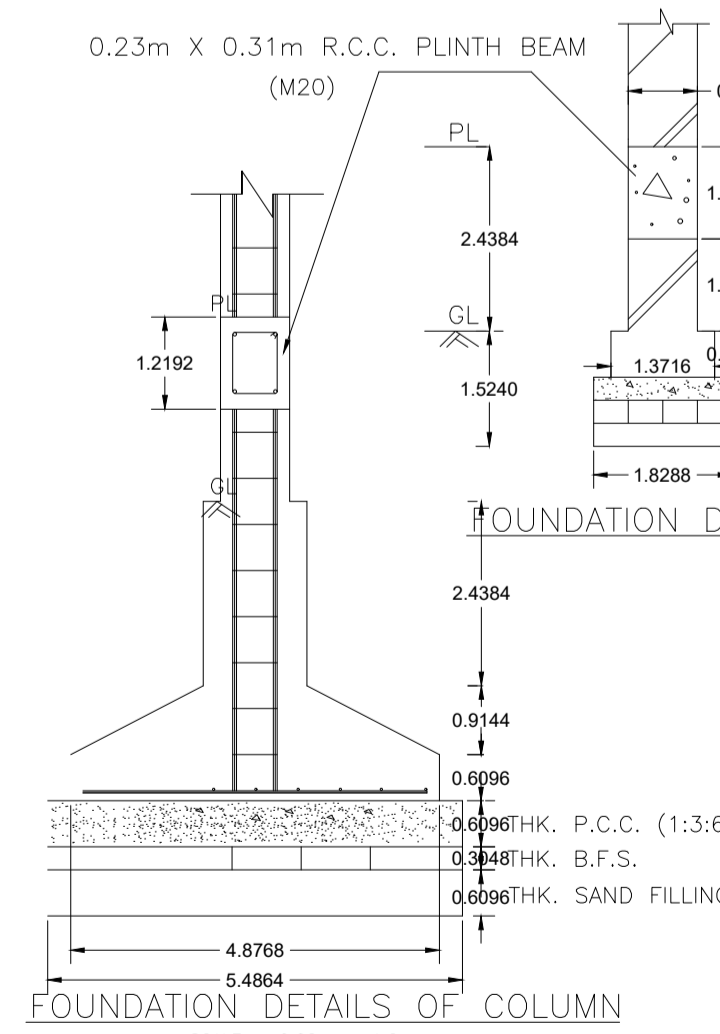

FOUNDATION DETAILS OF COLUMN

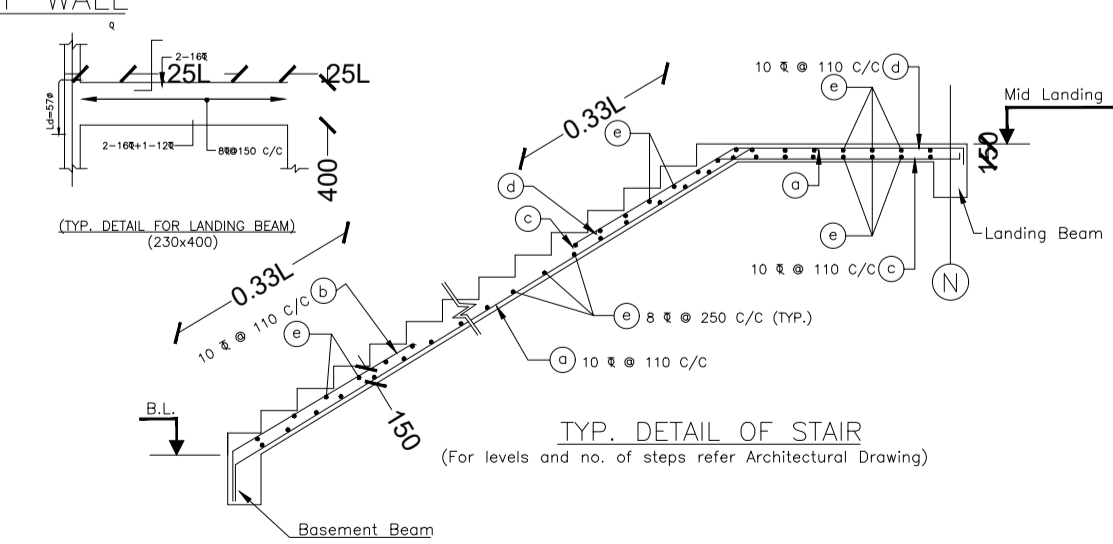
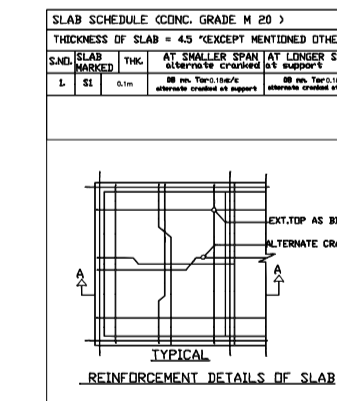

TYP. DETAIL OF STAIR

Proposal Basic Information

Proposal File No.	MADA/BP/0150/2021
Owner Name	MANOJ KUMAR SINHA MOHAN PRASAD SINHA SACHINDRA KUMAR VERMA
Khata No	96(new 239)
Plot No	309 ( NEW 407)
Village Name	Damodarapur
Use	Residential
SubUse	Bungalow/ Dwelling / Non Apartment

AREA STATEMENT MINERAL AREA DEVELOPMENT AUTHORITY	VERSION NO. 1.0.60	VERSION DATE: 16/10/2020
PROJECT DETAIL:		
Region: JHARKHAND URBAN LOCAL BODIES	Plot Use: Residential	
District: DHANBAD	Plot SubUse: Bungalow/ Dwelling / Non Apartment	
Authority: MINERAL AREA DEVELOPMENT AUTHORITY	PlotNearby/ReligiousStructure: NA	
Inward No: MADA/BP/0150/2021	Plot/SubPlot No: 309 ( NEW 407)	
Application Type: General Proposal	North: Plot No. - 312	
Project Type: Building Permission	South: Road Width - 3.8	
Nature of Development: New	East: Road Width - 3	
Location of Development Area: Old Area	West: Plot No. - Mala Sinha	
AREA DETAILS:		
AREA OF PLOT (Minimum)	(A)	199.20
NET AREA OF PLOT(Gross Plot Area - Deduction from Gross Plot area)	(A-Deductions)	199.20
Deduction for Balance Plot Area(from Gross Plot Area)		
Common Plot		10.23
Total		10.23
BALANCE AREA OF PLOT(Net Plot Area - Recreational/Amenity space)	(A-Deductions)	188.97
PLOT AREA FOR COVERAGE(Net Plot Area)	(A-Deductions)	199.20
Plot Area for FAR (Net Plot Area + Road Widening Area)	(A-Deductions)	199.20
COVERAGE CHECK		
Permissible Coverage area ( 70.00 % )		139.44
Proposed Coverage Area ( 62.61 % )		124.71
Total Prop. Coverage Area ( 62.61 % )		124.71
Balance coverage area ( 7.39 % )		14.73
FAR CHECK		
Perm. FAR Area ( 1.50 )		298.80
Total Perm. FAR area		298.80
Residential FAR		249.43
Proposed FAR Area		249.43
Total Proposed FAR Area		249.43
Consumed FAR (Factor)		1.25
Balance FAR Area		49.37
BUILT UP AREA CHECK		
Total Proposed BuiltUp Area		249.42
ARCHITECT (Regd)	Sushil Kumar	
ENGINEER (Regd)		
SUPERVISOR (Regd)		
OWNER (Regd)	MANOJ KUMAR SINHA MOHAN PRASAD SINHA SACHINDRA KUMAR VERMA	
DEVELOPMENT AUTHORITY		LOCAL BODY

COLOR INDEX

PLOT BOUNDARY	Black
ABUTTING ROAD	Green
PROPOSED CONSTRUCTION	Red
COMMON PLOT	Yellow
ROAD WIDENING AREA	Blue
EXISTING (To be retained)	Orange
EXISTING (To be demolished)	Grey

Buildingwise Floor FAR Details

Floor Name	Building Name V (1)		Total	
	Proposed Built Up Area (Sq.mt.)	Proposed FAR Area (Sq.mt.)	Total Proposed Built Up Area (Sq.mt.)	Total FAR Area (Sq.mt.)
Ground Floor	124.71	124.71	124.71	124.71
First Floor	124.71	124.71	124.71	124.71
Terrace Floor	0.00	0.00	0.00	0.00
Total :	249.42	249.42	249.42	249.42

Building USE/SUBUSE Details

Building Name V (1)	Building Use Residential	Building SubUse Residential Bldg/Apartment	Building Structure Non-Highrise

FAR & Tenement Details (Table 4c-1)

Building	No. of Same Bldg	Total Built Up Area (Sq.mt.)	Proposed FAR Area (Sq.mt.) Resi.	Total FAR Area (Sq.mt.)	Total Consumed Additional FAR Area (Sq.mt.)	Tnmt (No.)
V (1)	1	249.42	249.42	249.42	249.42	01
Grand Total :	1	249.42	249.42	249.42	249.42	01

UnitBUA Table for Building :V (1)

FLOOR	Name	UnitBUA Type	UnitBUA Area (Sq.mt.)	Carpet Area (Sq.mt.)	No. of Rooms	No. of Tenement
GROUND FLOOR PLAN	SPLIT 1	FLAT	249.43	249.41	4	1
FIRST FLOOR PLAN	SPLIT 1	FLAT	0.00	0.00	8	0
Total:	-	-	249.43	249.41	12	1

LTP NAME AND SIGNATURE	STRUCTURAL ENG'S NAME AND SIGNATURE	BUILDER NAME AND SIGNATURE	DIGITAL SIGNATURE
Sushil Kumar MADA/ENG/0009/2019			

Proposal Basic Information	
Proposal File No.	MADA/BP/0150/2021
Owner Name	MANOJ KUMAR SINHA MOHAN PRASAD SINHA SACHINDRA KUMAR VERMA
Khata No	96(new 239)
Plot No	309 ( NEW 407)
Village Name	Damodarpur
Use	Residential
SubUse	Bungalow/ Dwelling / Non Apartment

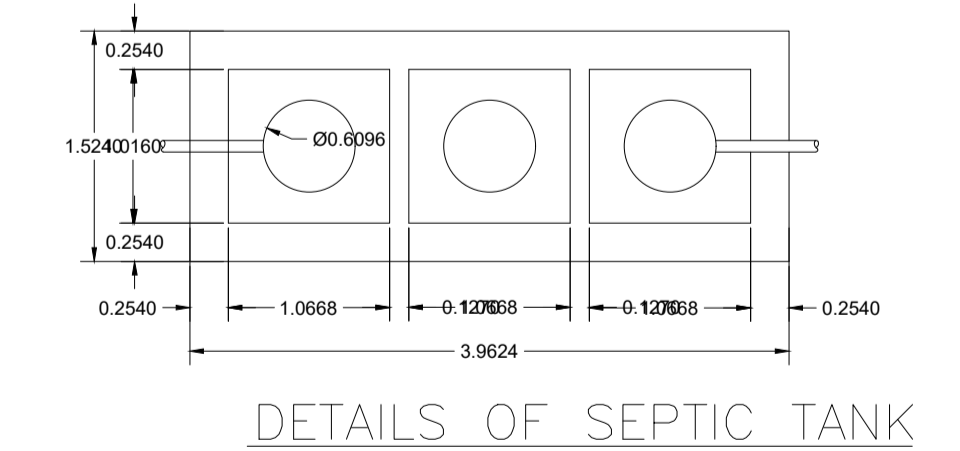
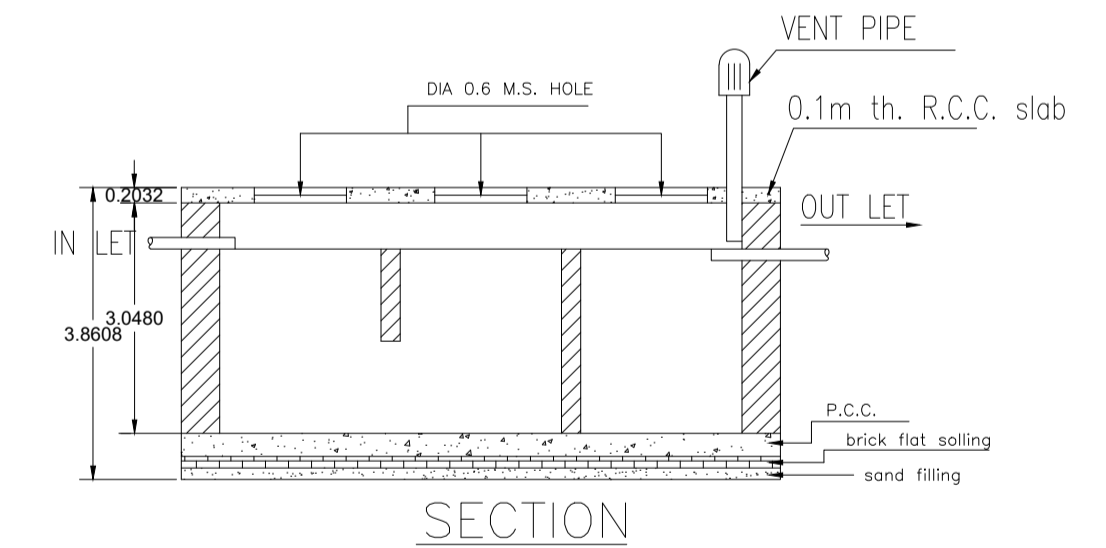
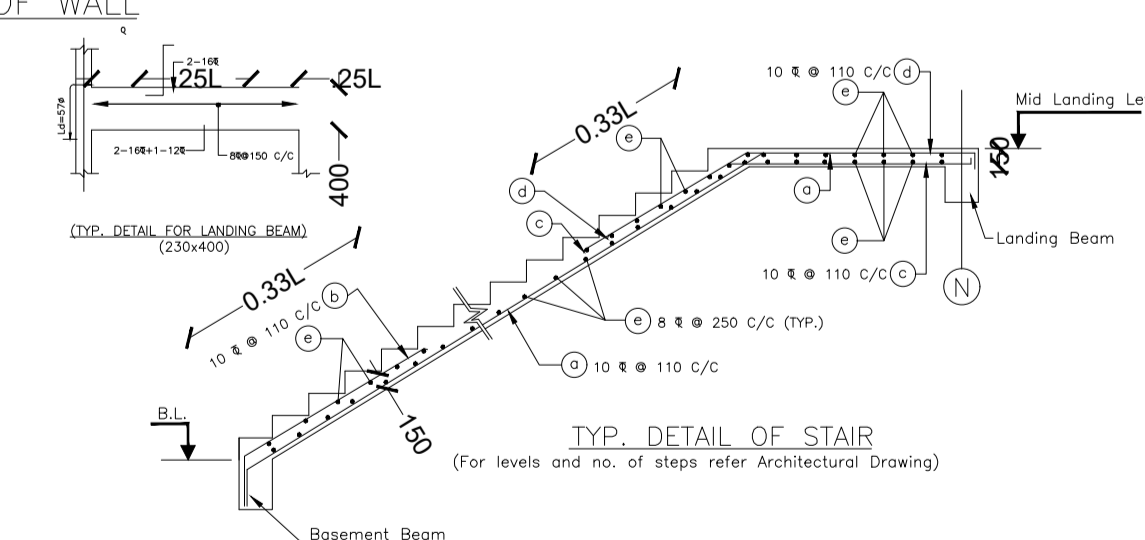
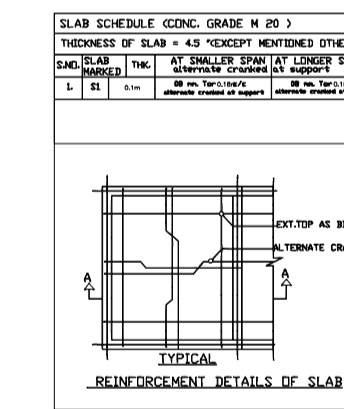
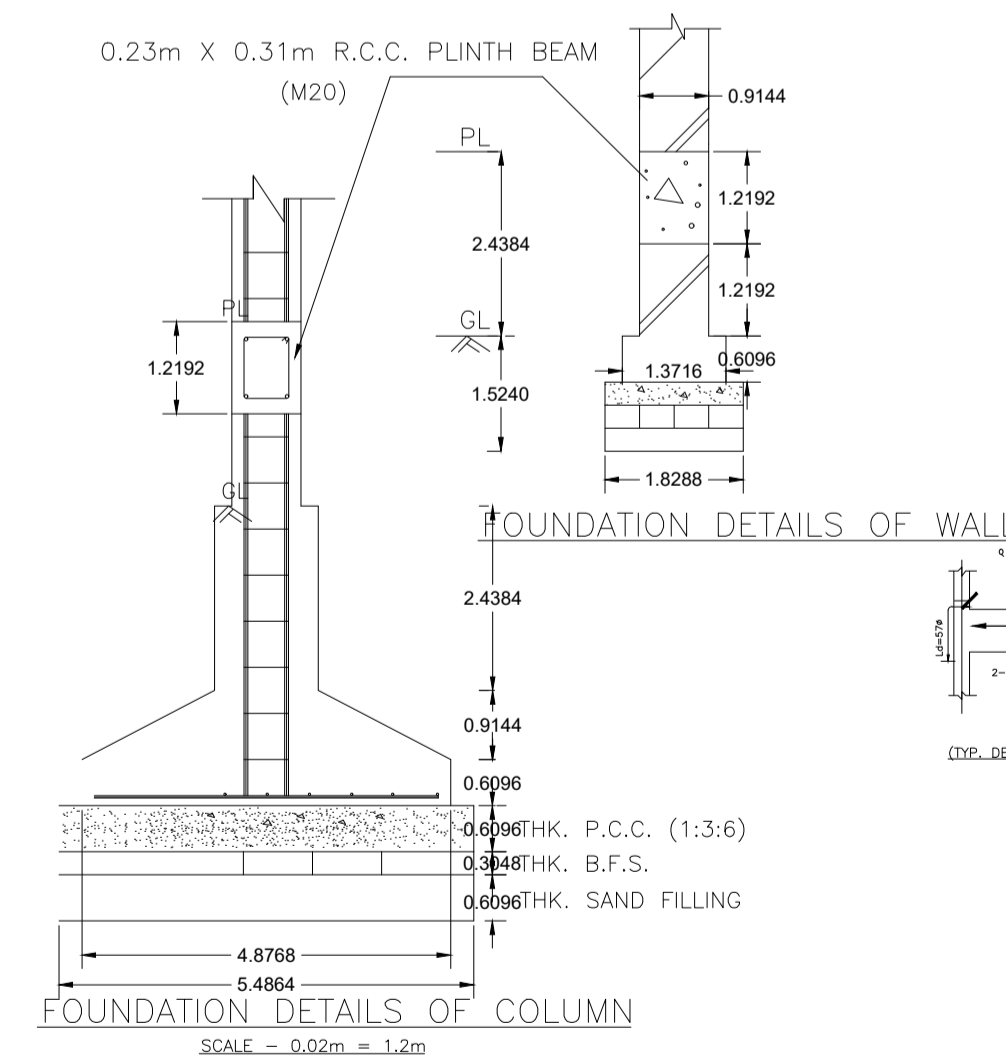
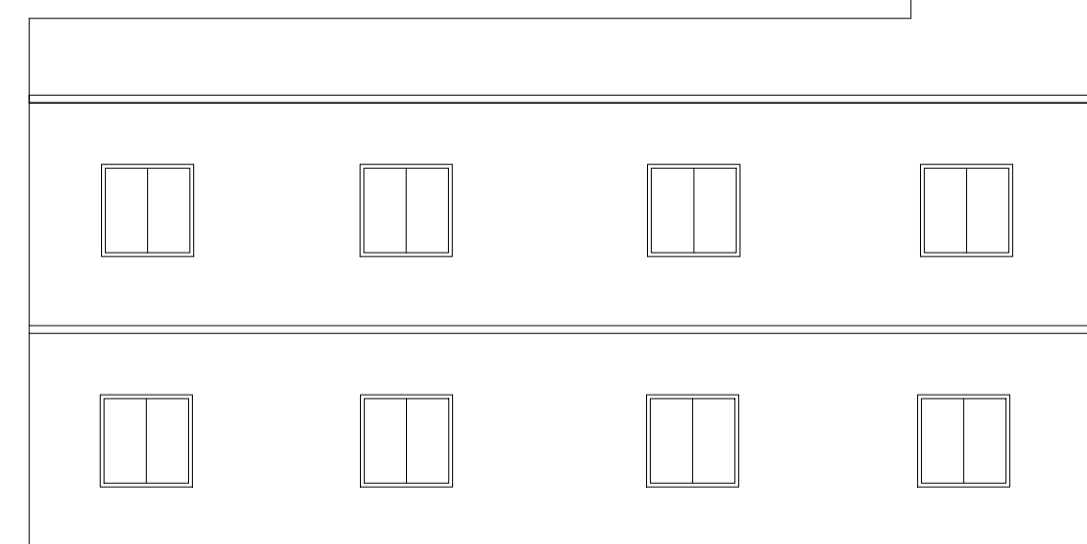
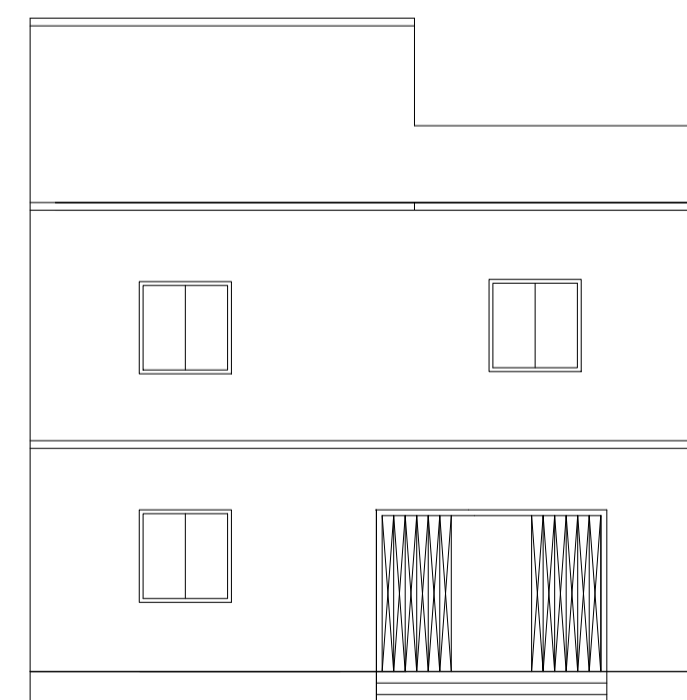
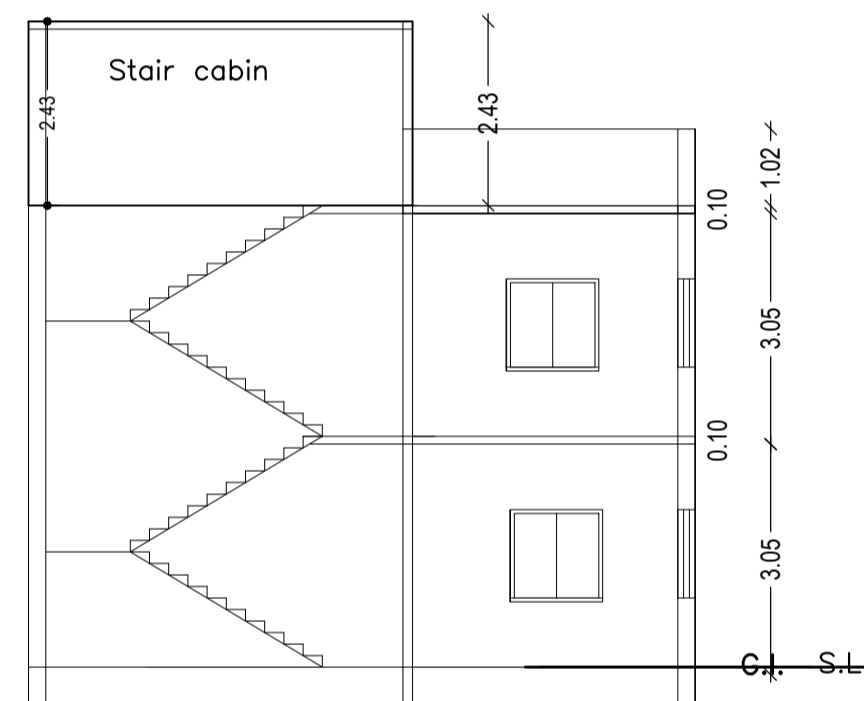
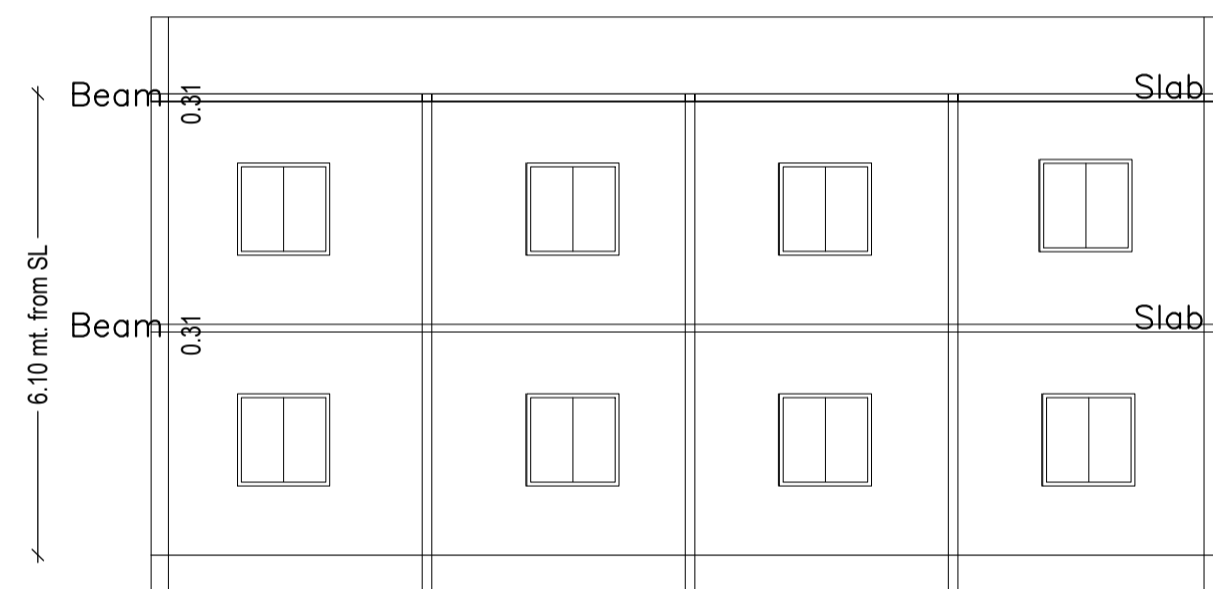
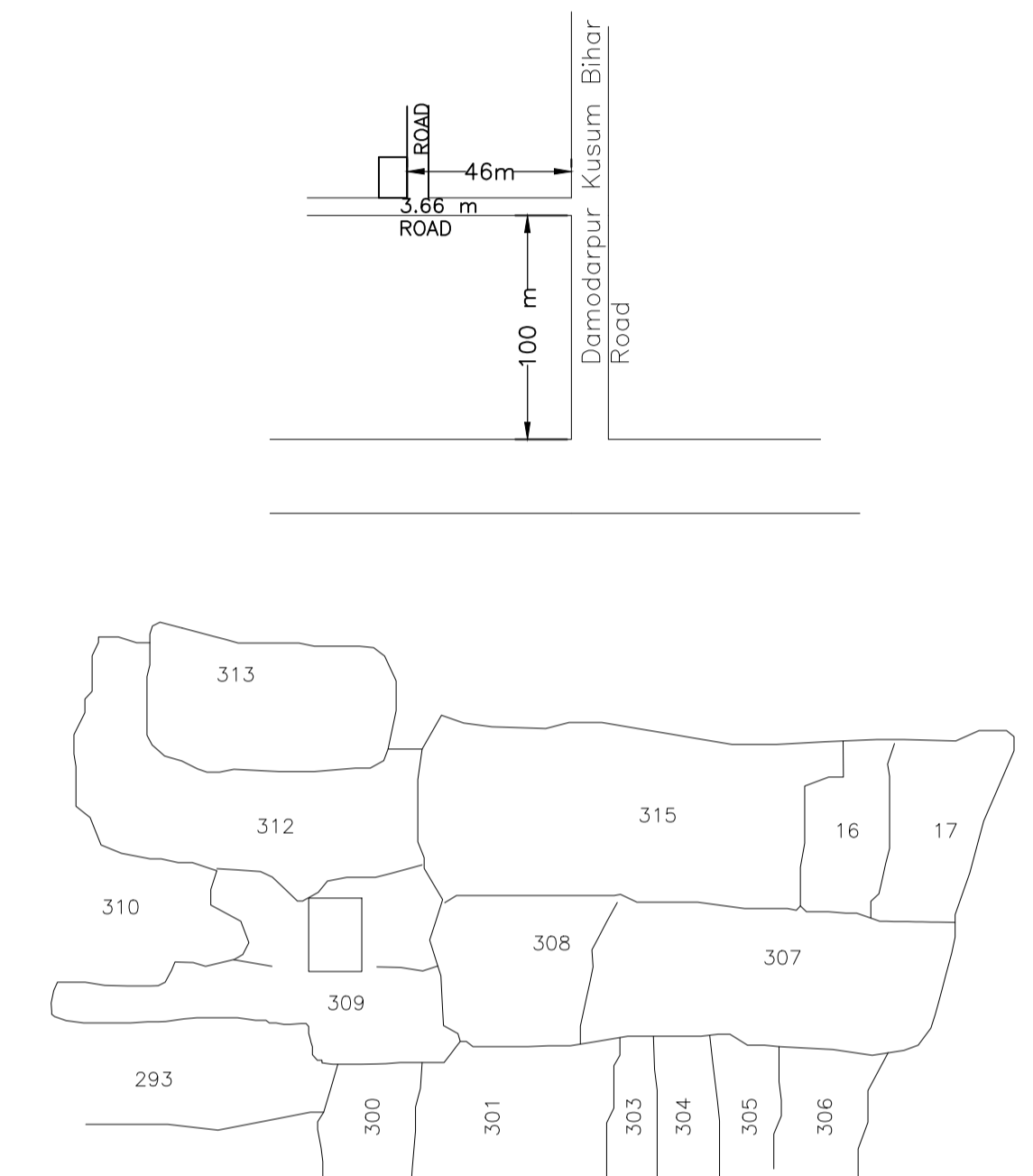
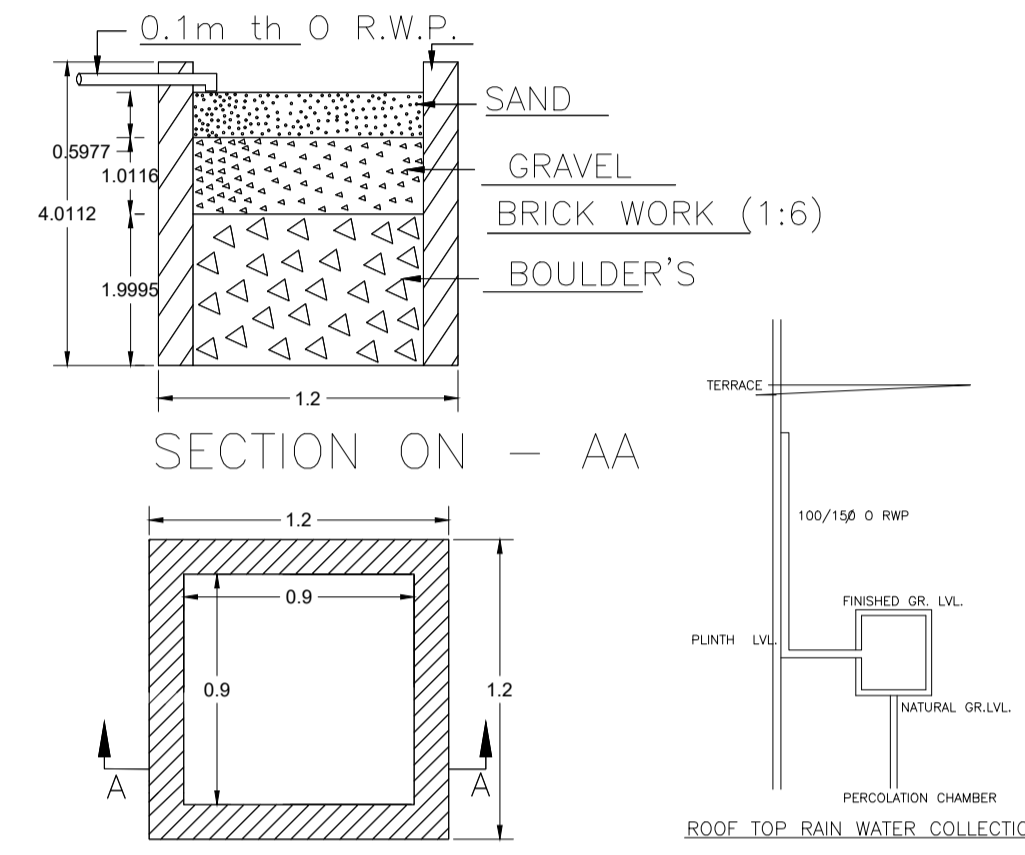
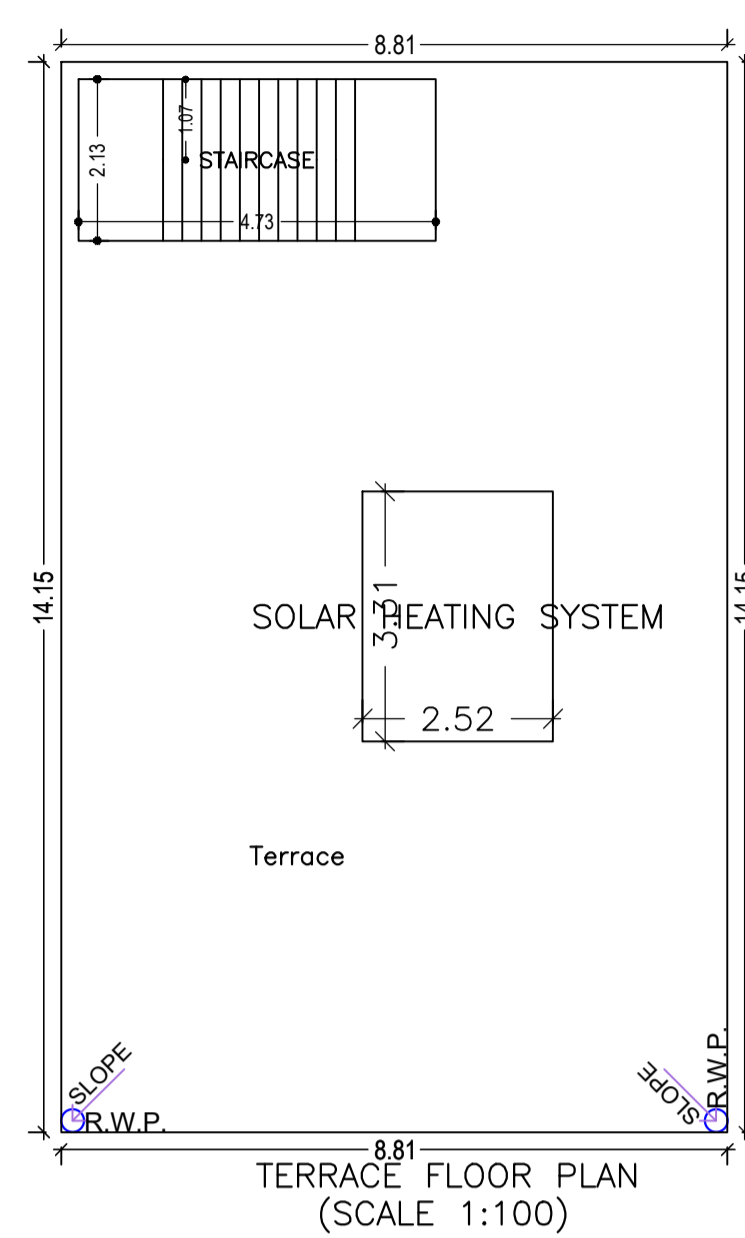
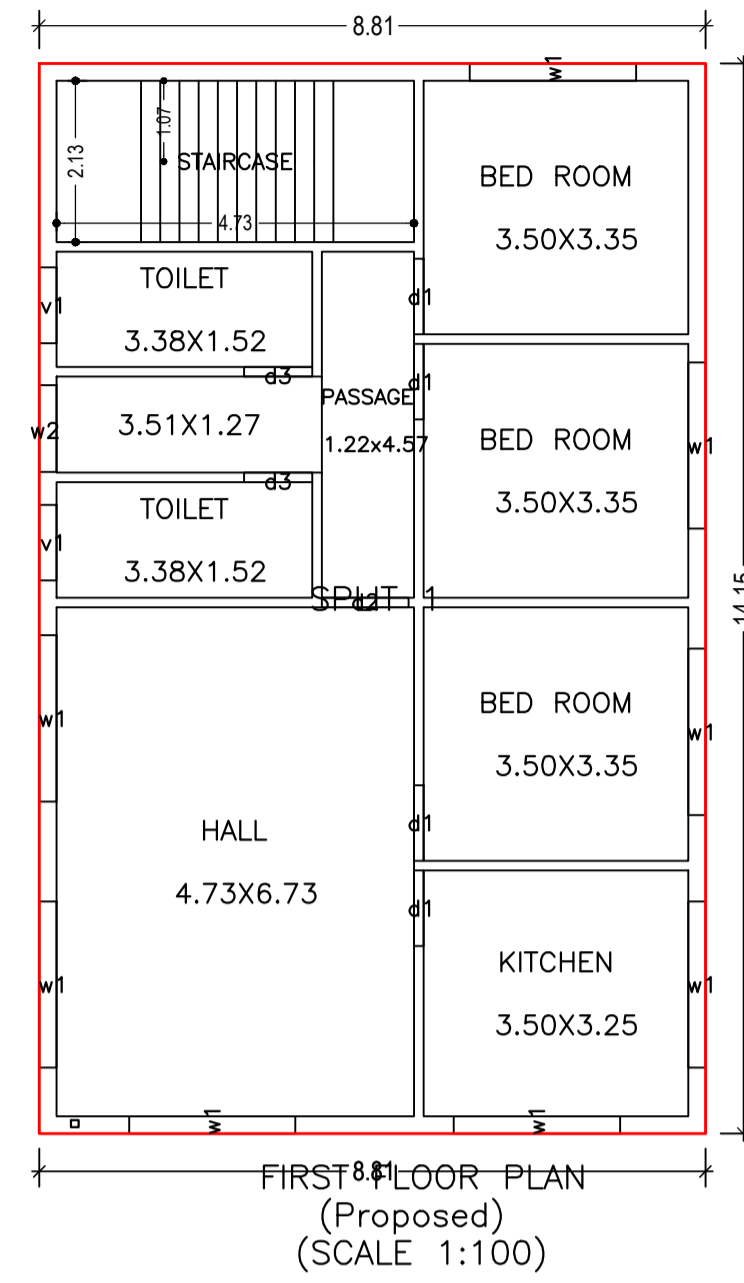
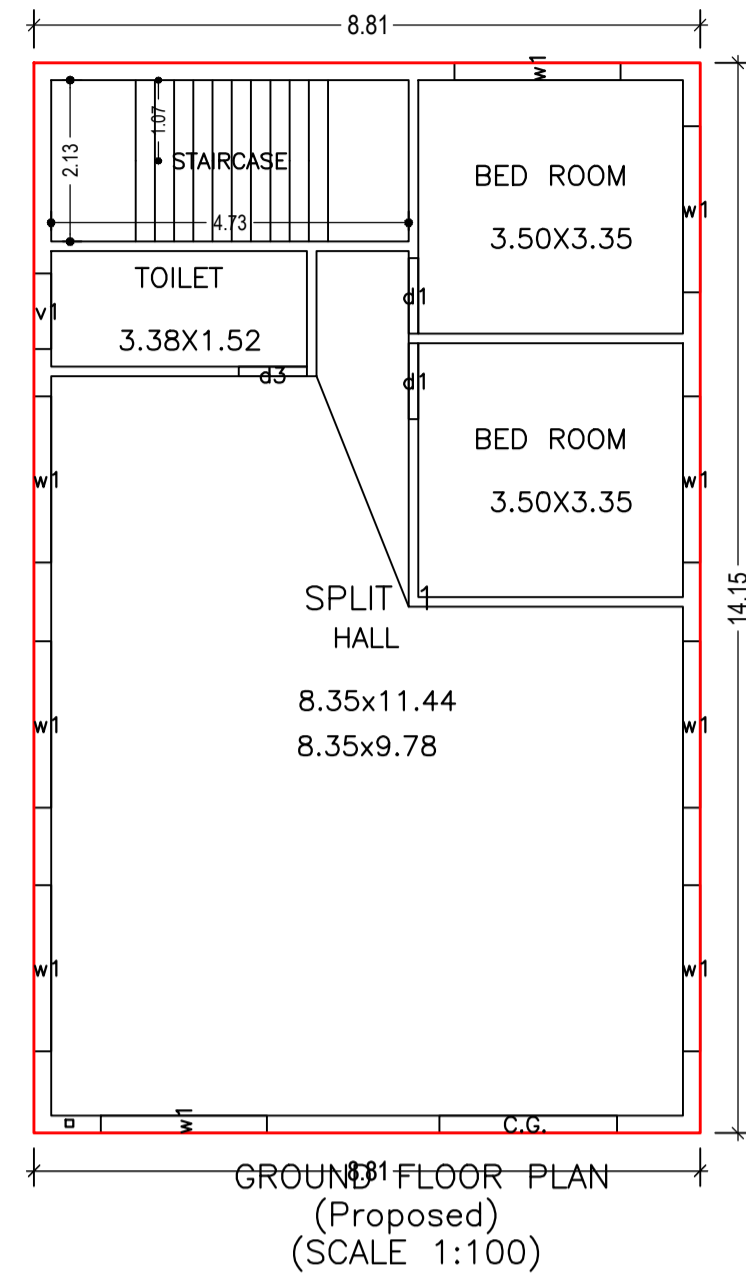

LTP NAME AND SIGNATURE	STRUCTURAL ENG'S NAME AND SIGNATURE	BUILDER NAME AND SIGNATURE	DIGITAL SIGNATURE
Sushil Kumar MADA/ENG/0009/2019			