

Proposal Basic Information

Proposal File No.	MADA/BP/0215/2021
Owner Name	1. SRI RAJEEV KUMAR DAS.2. SMT NITU KUMARI DAS
Khata No	OLD 03, NEW 223
Plot No	1450(o)1617(n)
Village Name	Nawadih
Use	Residential
SubUse	Bungalow/ Dwelling / Non Apartment

AREA STATEMENT MINERAL AREA DEVELOPMENT AUTHORITY	VERSION NO.: 1.0.62 VERSION DATE: 16/10/2020
PROJECT DETAIL:	
Region: JHARKHAND URBAN LOCAL BODIES	Plot Use: Residential
District: DHANBAD	Plot SubUse: Bungalow/ Dwelling / Non Apartment
Authority: MINERAL AREA DEVELOPMENT AUTHORITY	PlotNearby/ReligiousStructure: NA
Inward No: MADA/BP/0215/2021	Plot/SubPlot No: 1450(o)1617(n)
Application Type: General Proposal	North: CTS No. - SUSILA DEVI
Project Type: Building Permission	South: Plot No. - 1451 AND SEMMA PANDRAPALA
Nature of Development: New	East: Road Width - 6.10
Location of Development Area: Old Area	West: Plot No. - 1450
AREA DETAILS:	
AREA OF PLOT (Minimum)	(A) 254.59 SQ.MT.
NET AREA OF PLOT(Gross Plot Area - Deduction from Gross Plot area)	(A-Deductions) 254.59
Common Plot	14.23
BALANCE AREA OF PLOT(Net Plot Area - Recreational/Amenity space)	(A-Deductions) 240.35
Plot Area for FAR (Net Plot Area + RoadWidening Area)	(A-Deductions) 254.59
COVERAGE CHECK	
Permissible Coverage area (60.00 %)	152.75
Proposed Coverage Area (49.57 %)	126.20
Total Prop. Coverage Area (49.57 %)	126.20
Balance coverage area (10.43 %)	26.55
FAR CHECK	
Perm. FAR Area (1.50)	381.89
Total Perm. FAR area	381.89
Residential FAR	378.60
Proposed FAR Area	378.60
Total Proposed FAR Area	378.60
Consumed FAR (Factor)	1.49
Balance FAR Area	3.29
BUILT UP AREA CHECK	
Total Proposed BuiltUp Area	378.60
ARCHITECT (Regd)	ASHOK KUMAR
ENGINEER (Regd)	
SUPERVISOR (Regd)	
OWNER (Regd)	1. SRI RAJEEV KUMAR DAS.2. SMT NITU KUMARI DAS
DEVELOPMENT AUTHORITY	LOCAL BODY

COLOR INDEX

PLOT BOUNDARY	Black
ABUTTING ROAD	Green
PROPOSED CONSTRUCTION	Red
COMMON PLOT	Yellow
ROAD WIDENING AREA	Blue
EXISTING (To be retained)	Blue
EXISTING (To be demolished)	Yellow

SCHEDULE OF DOOR:

BUILDING NAME	NAME	LENGTH	HEIGHT	NOS
A (BUILDING)	D1	0.75	2.10	03
A (BUILDING)	D1	0.90	2.10	21
A (BUILDING)	D	1.07	2.10	06

SCHEDULE OF WINDOW/VENTILATION:

BUILDING NAME	NAME	LENGTH	HEIGHT	NOS
A (BUILDING)	V	0.80	1.20	06
A (BUILDING)	W4	1.06	1.20	03
A (BUILDING)	W4	1.21	1.20	06
A (BUILDING)	W1	1.36	1.20	03
A (BUILDING)	W	1.41	1.20	03
A (BUILDING)	W1	1.75	1.20	03
A (BUILDING)	W1	1.81	1.20	12

Building :A (BUILDING)

Floor Name	Total Built Up Area (Sq.mt.)	Proposed FAR Area (Sq.mt.) Resi.	Total FAR Area (Sq.mt.)	Total Consumed Additional FAR Area (Sq.mt.)	Trmt (No.)
Ground Floor	126.20	126.20	126.20	126.20	01
First Floor	126.20	126.20	126.20	126.20	00
Second Floor	126.20	126.20	126.20	126.20	00
Terrace Floor	0.00	0.00	0.00	0.00	00
Total :	378.60	378.60	378.60	378.60	01
Total Number of Same Buildings :	1				
Total :	378.60	378.60	378.60	378.60	01

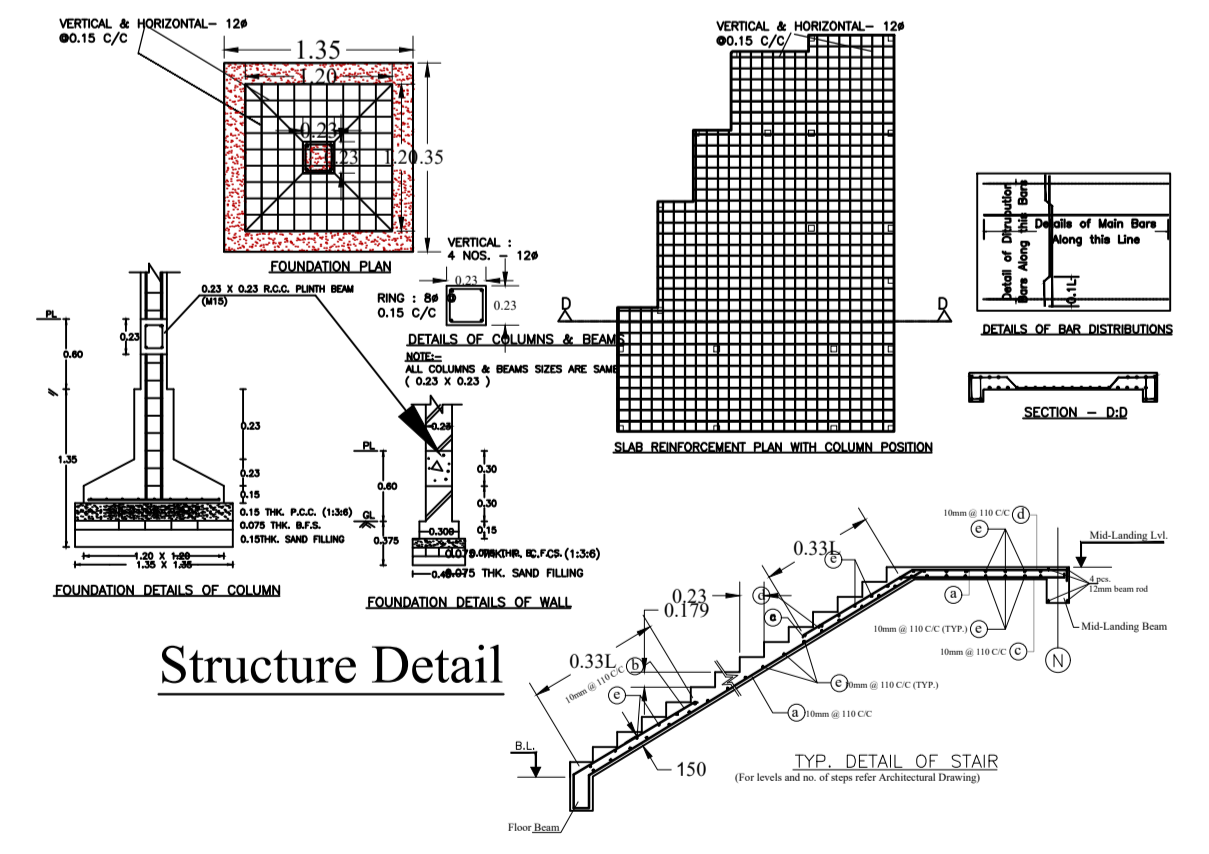
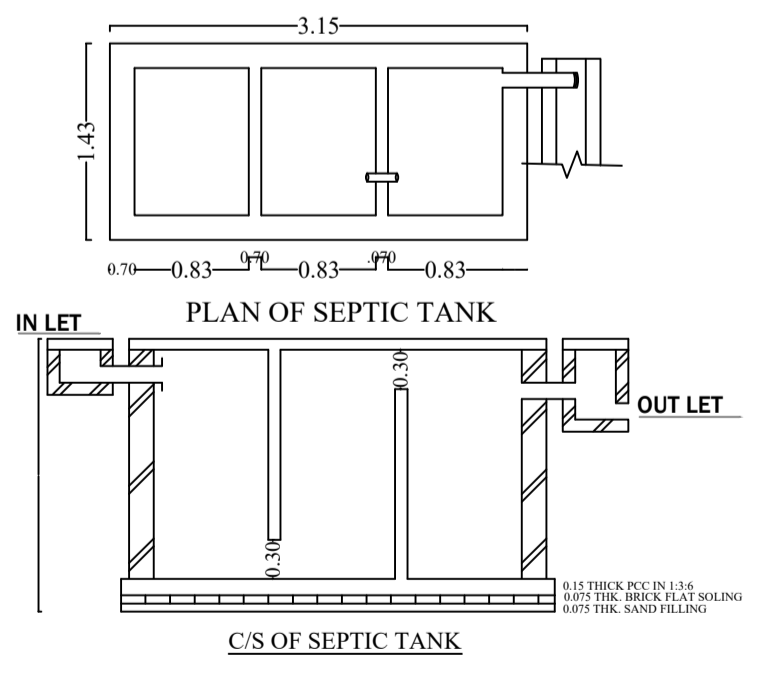
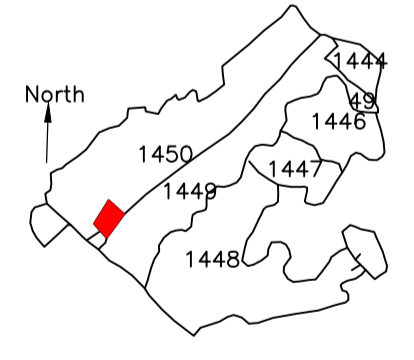

Buildingwise Floor FAR Details

Floor Name	Building Name		Total	
	Proposed Built Up Area (Sq.mt.)	Proposed FAR Area (Sq.mt.)	Total Proposed Built Up Area (Sq.mt.)	Total FAR Area (Sq.mt.)
Ground Floor	126.20	126.20	126.20	126.20
First Floor	126.20	126.20	126.20	126.20
Second Floor	126.20	126.20	126.20	126.20
Terrace Floor	0.00	0.00	0.00	0.00
Total :	378.60	378.60	378.60	378.60

Building USE/SUBUSE Details

Building Name	Building Use	Building SubUse	Building Structure
A (BUILDING)	Residential	Bungalow/ Dwelling / Non Apartment	Non-Highrise

FAR & Tenement Details (Table 4c-1)

Building	No. of Same Bldg	Total Built Up Area (Sq.mt.)	Proposed FAR Area (Sq.mt.) Resi.	Total FAR Area (Sq.mt.)	Total Consumed Additional FAR Area (Sq.mt.)	Trmt (No.)
A (BUILDING)	1	378.60	378.60	378.60	378.60	01
Grand Total :	1	378.60	378.60	378.60	378.60	01

UnitBUA Table for Building :A (BUILDING)

FLOOR	Name	UnitBUA Type	UnitBUA Area	Carpet Area	No. of Rooms	No. of Tenement
GROUND FLOOR	SPLIT 1	FLAT	378.60	378.54	11	1
TYPICAL -1& 2 FLOOR PLAN	SPLIT 1	FLAT	0.00	0.00	11	0
Total:	-	-	378.60	378.54	33	1

LTP NAME AND SIGNATURE	STRUCTURAL ENG'S NAME AND SIGNATURE	BUILDER NAME AND SIGNATURE	DIGITAL SIGNATURE
ASHOK KUMAR MADA/ENG/0007/2019			

Proposal Basic Information	
Proposal File No.	MADA/BP/0215/2021
Owner Name	1. SRI RAJEEV KUMAR DAS.2. SMT NITU KUMARI DAS
Khata No	OLD 03, NEW 223
Plot No	1450(o)1617(n)
Village Name	Nawadhi
Use	Residential
SubUse	Bungalow/ Dwelling / Non Apartment

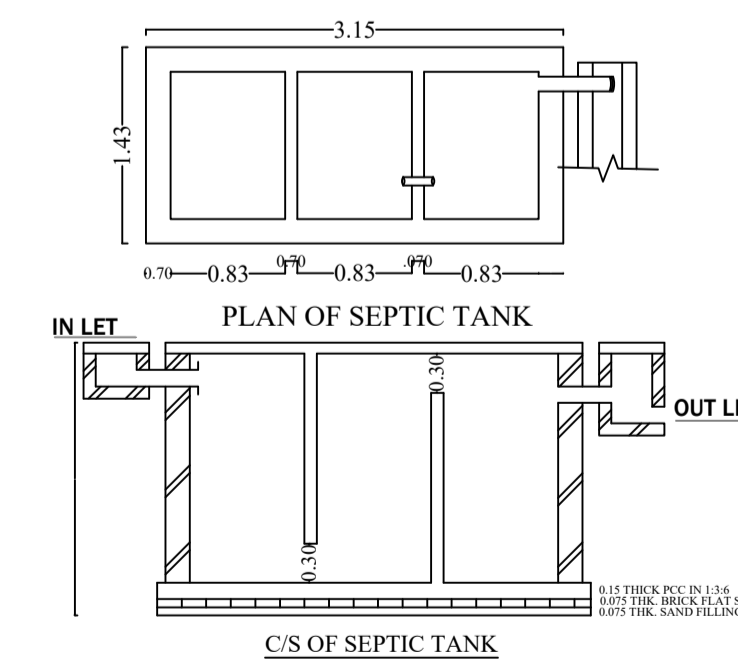
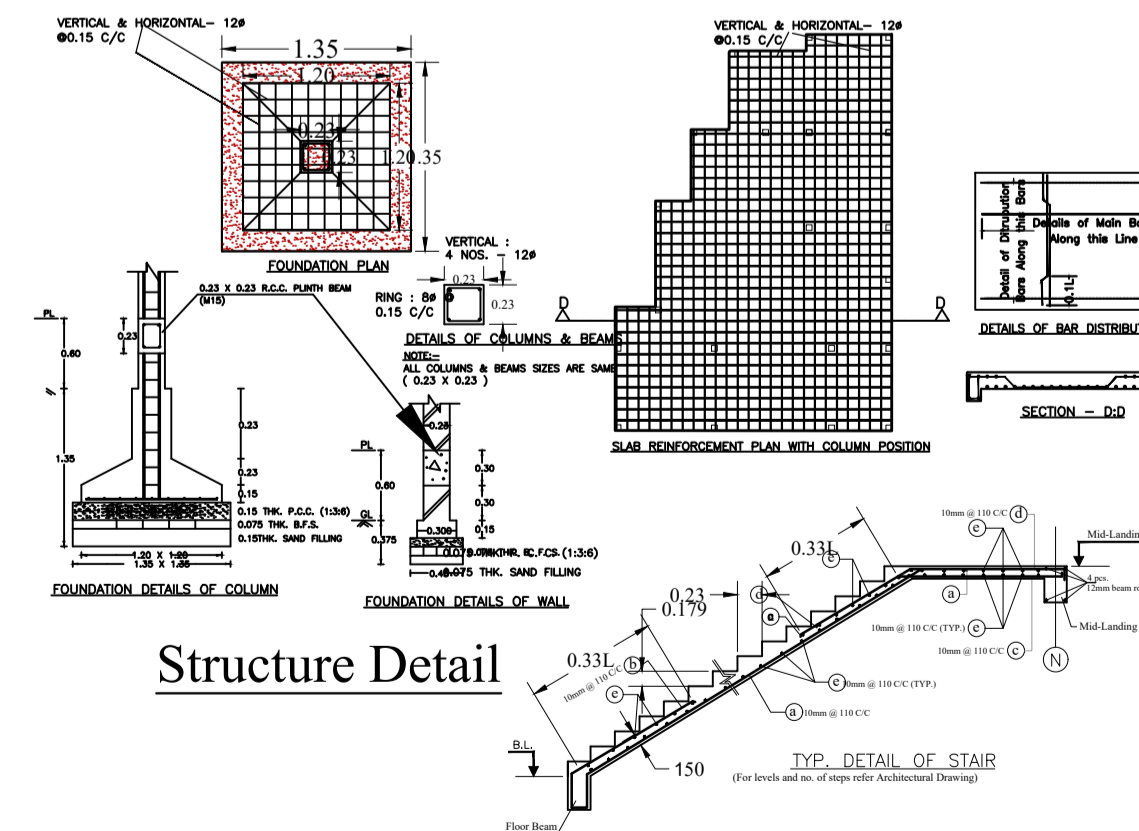
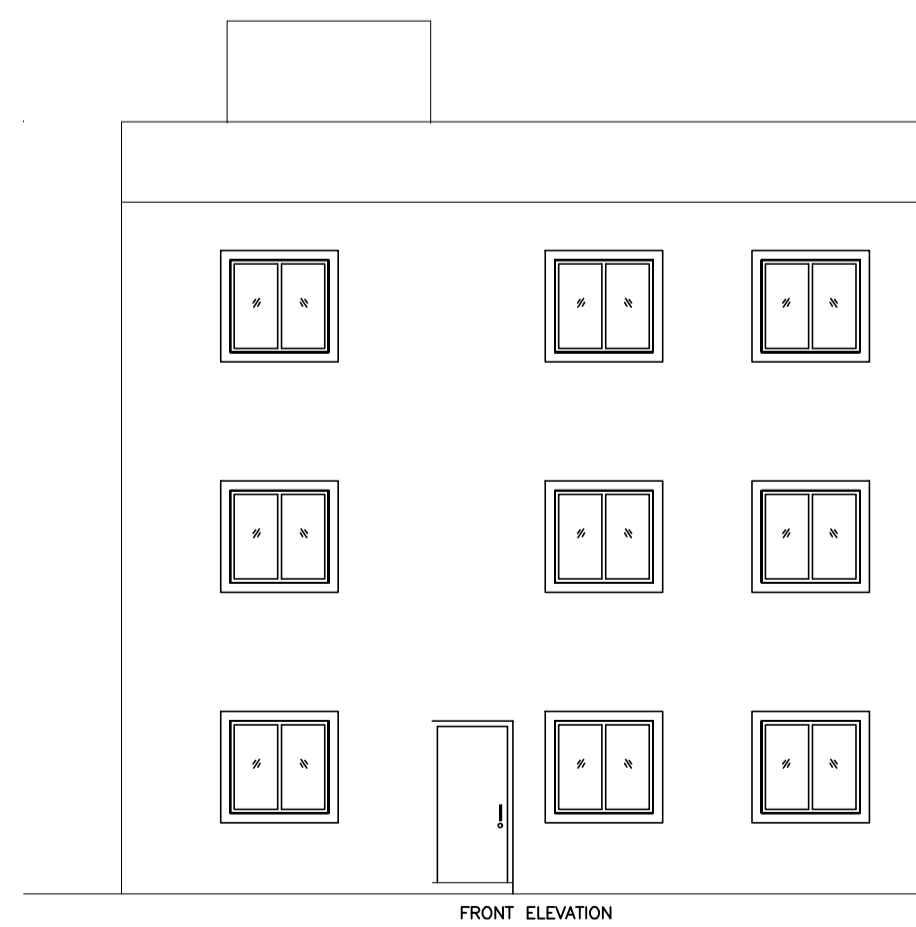
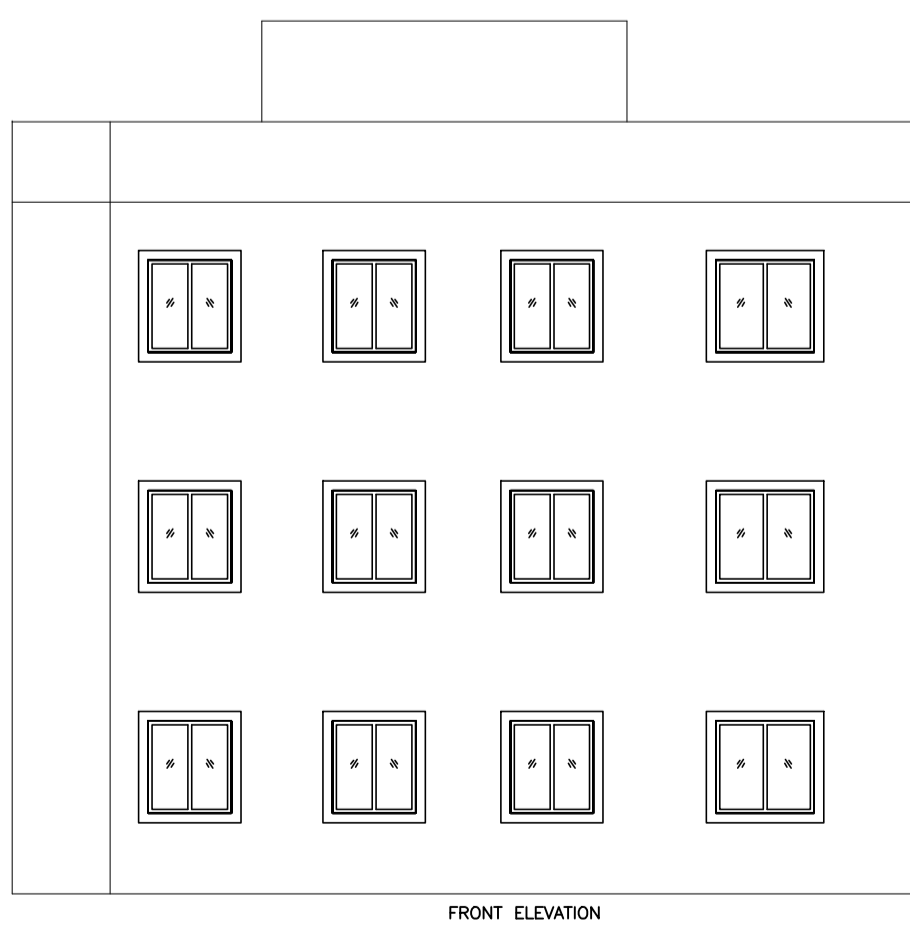
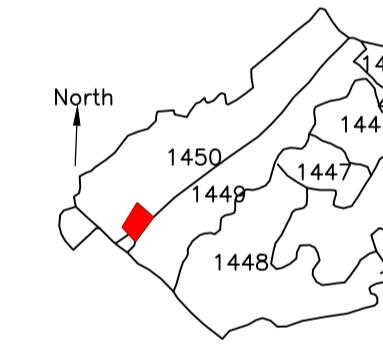
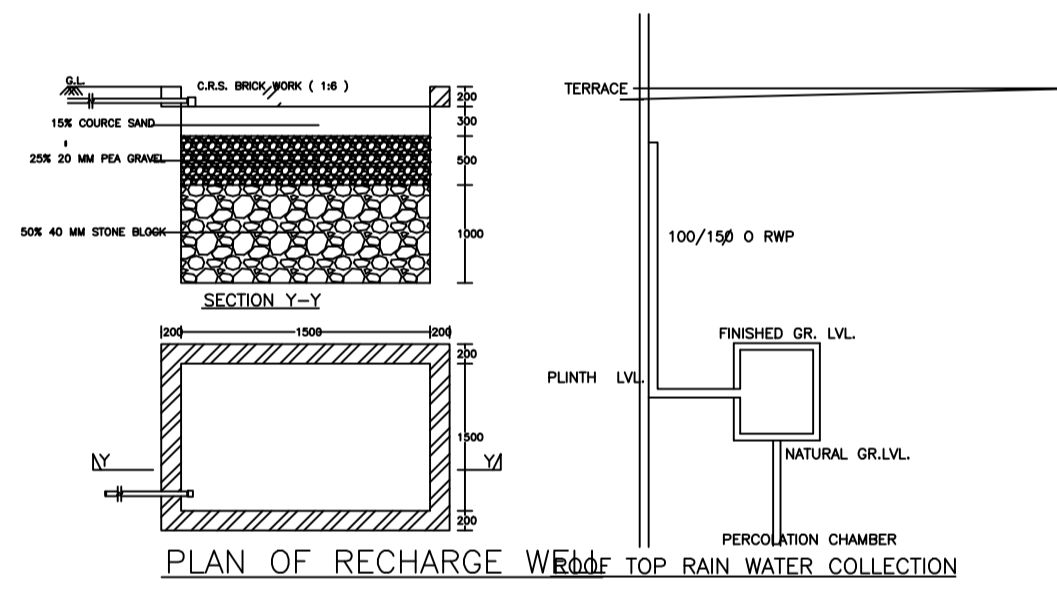
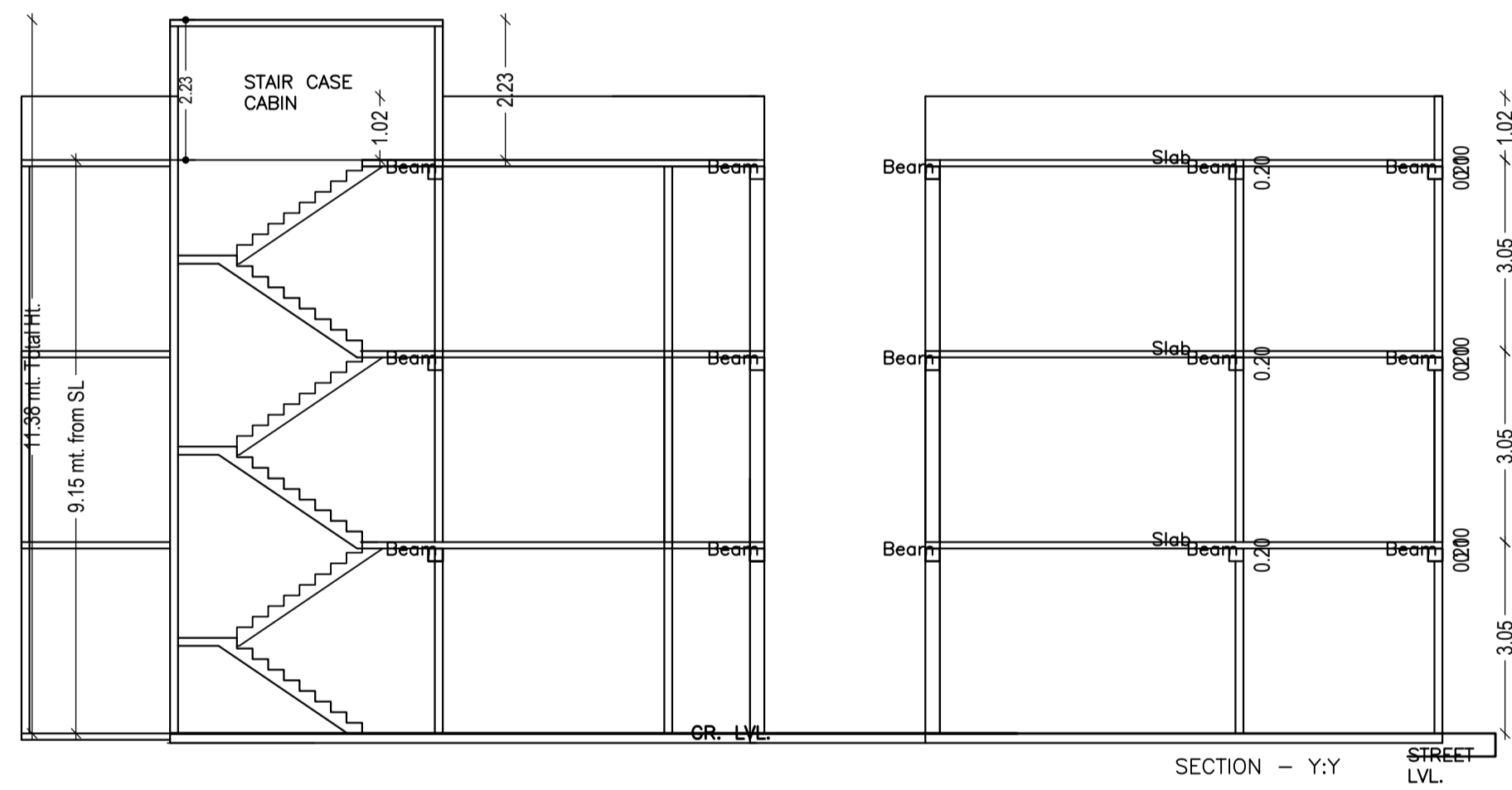
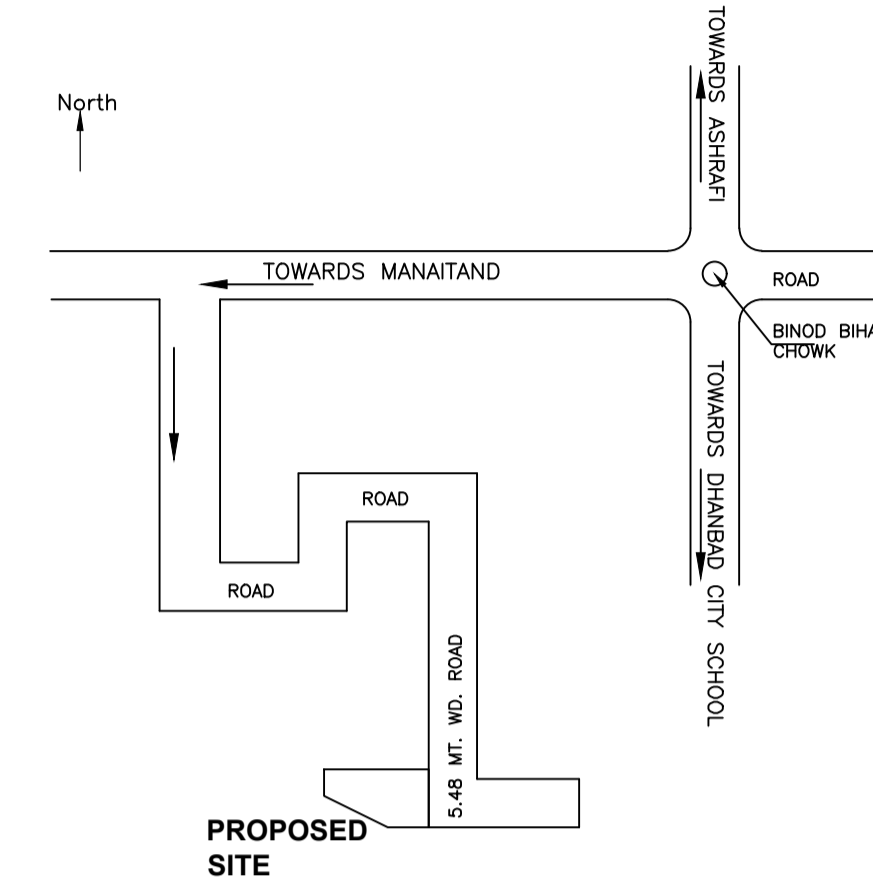
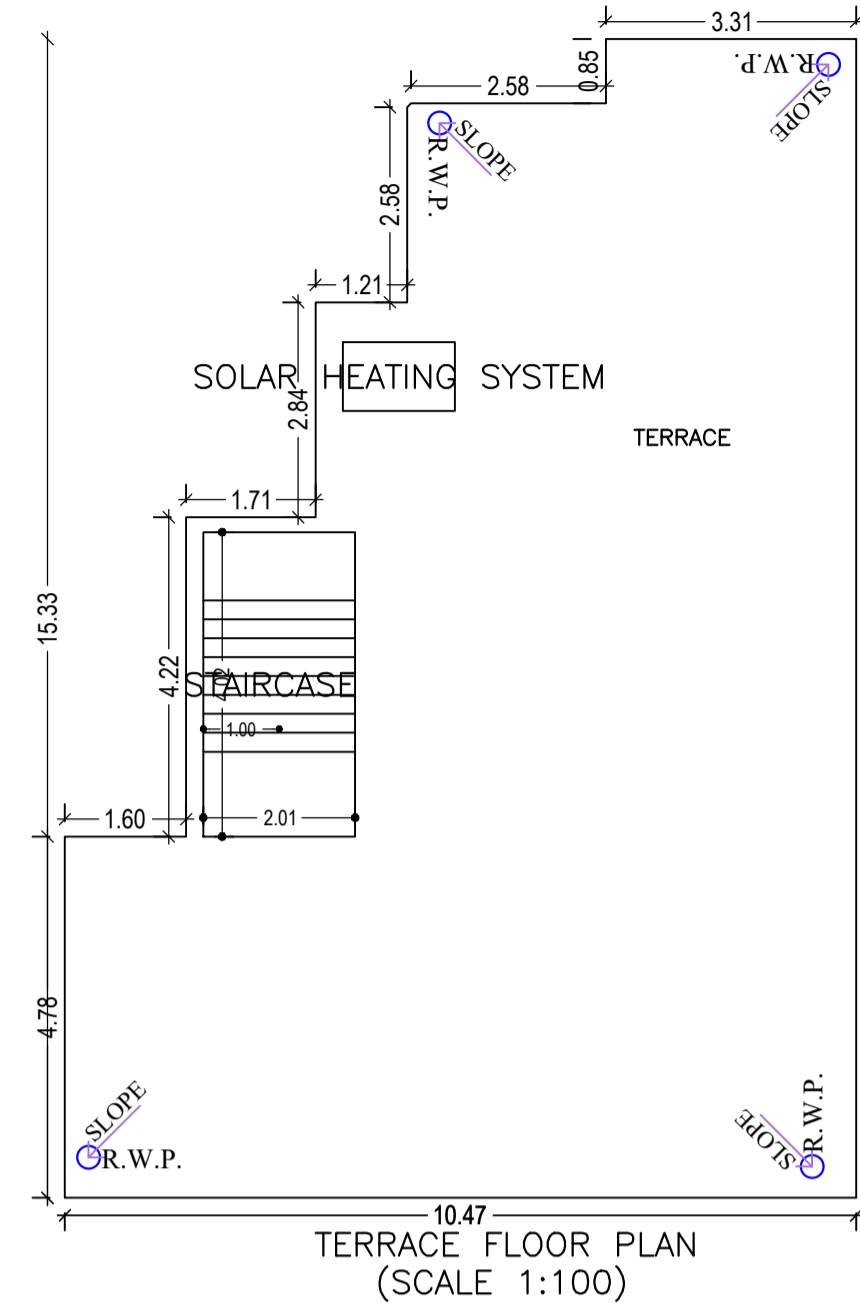
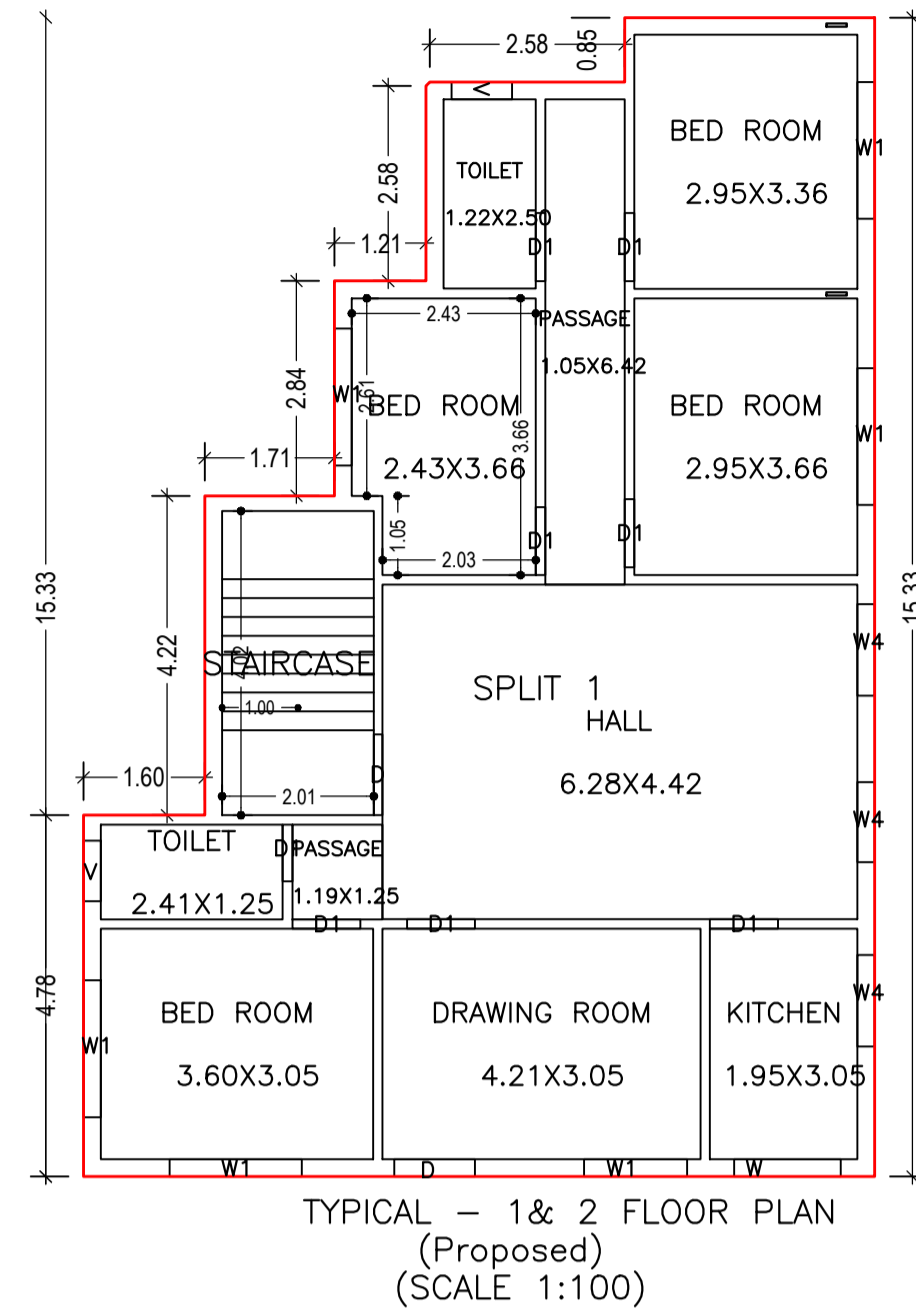
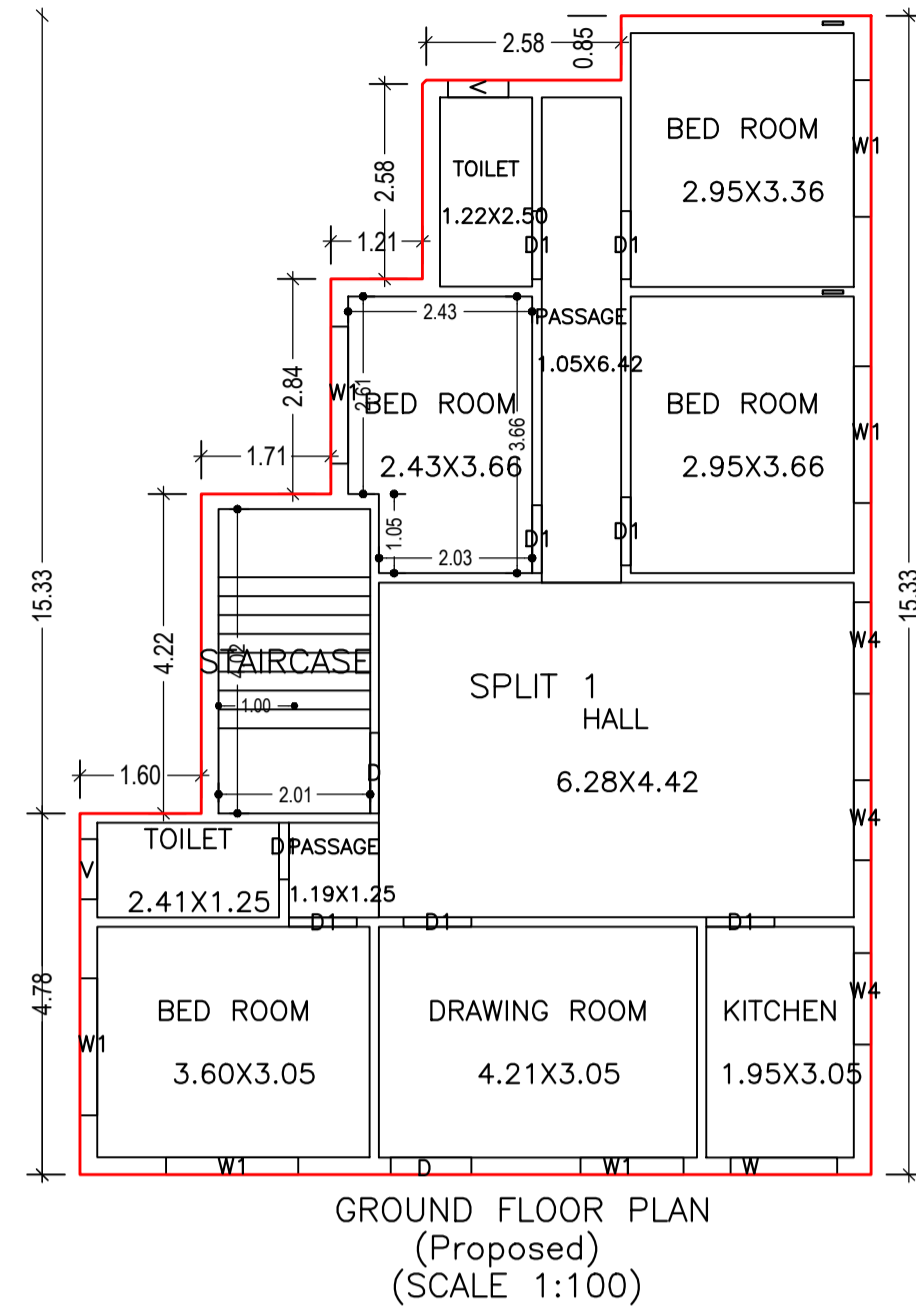

LTP NAME AND SIGNATURE	STRUCTURAL ENG'S NAME AND SIGNATURE	BUILDER NAME AND SIGNATURE	DIGITAL SIGNATURE
ASHOK KUMAR MADA/ENG/0007/2019			