

Project Title - PRAVIN KUMAR SINGH

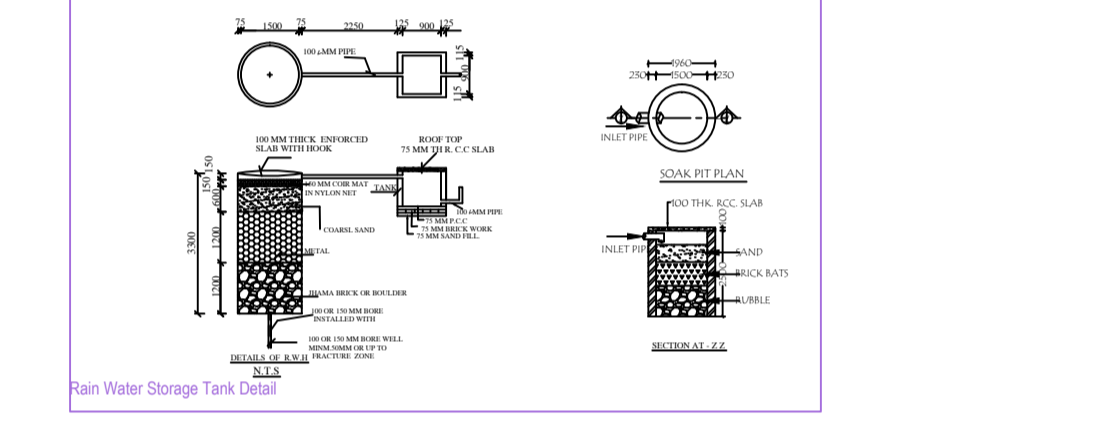
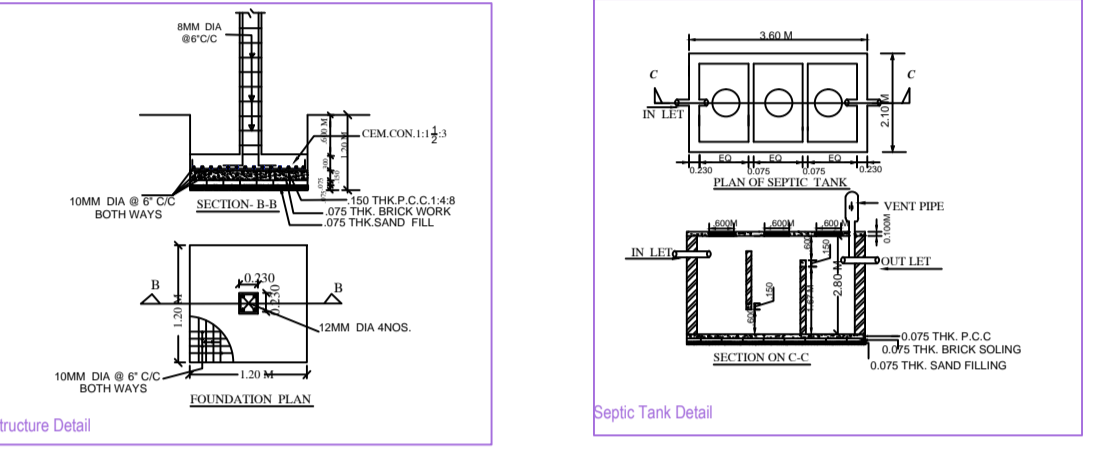
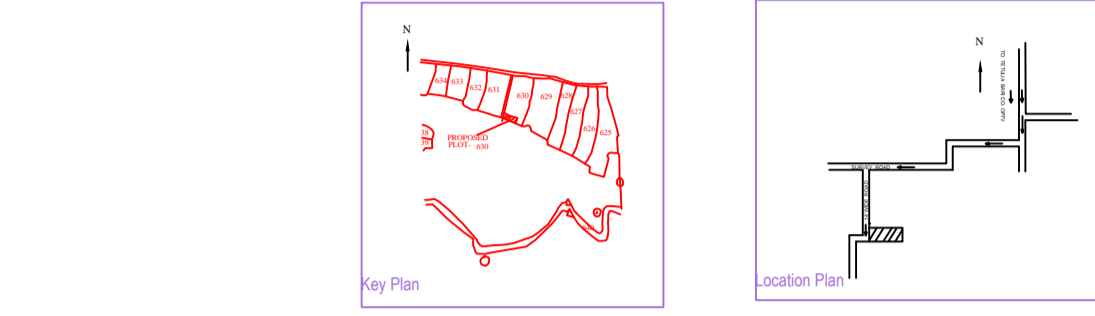
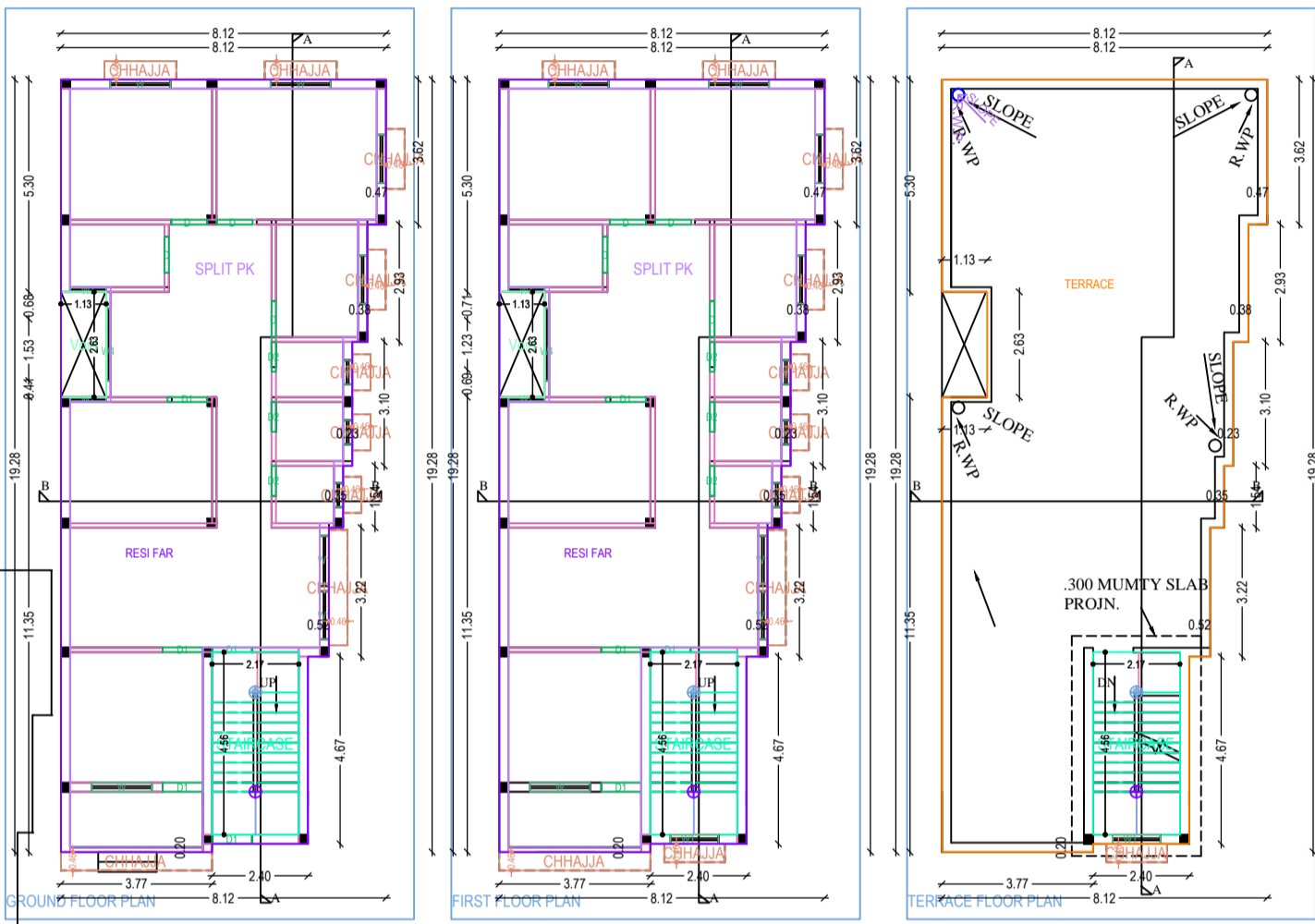
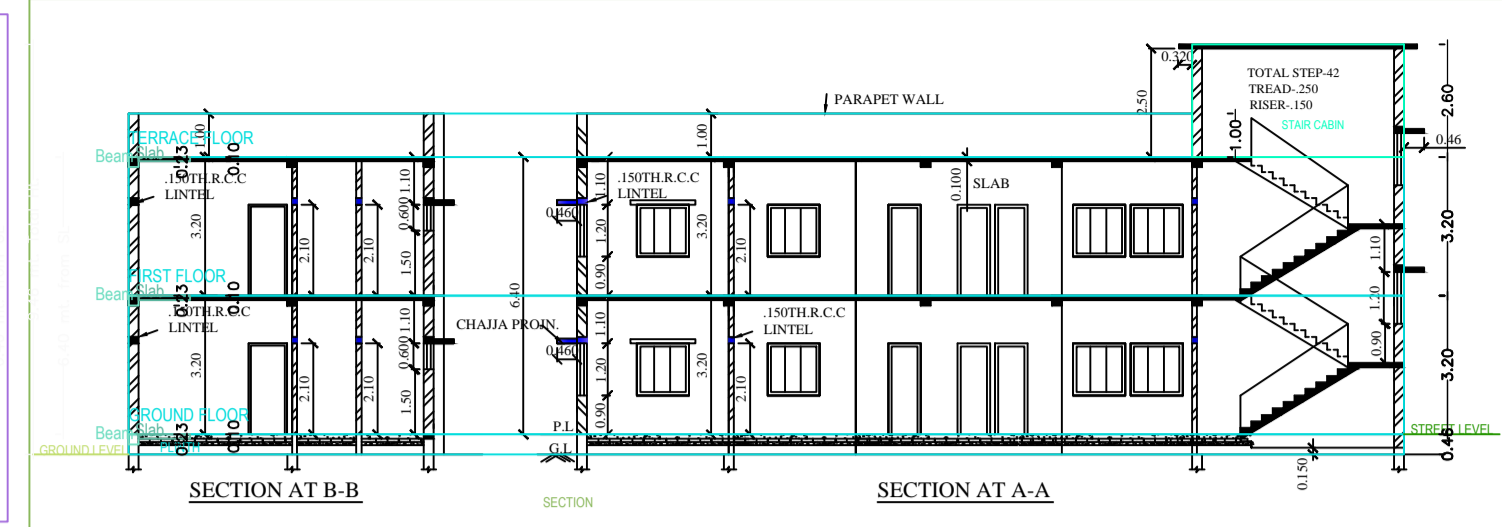
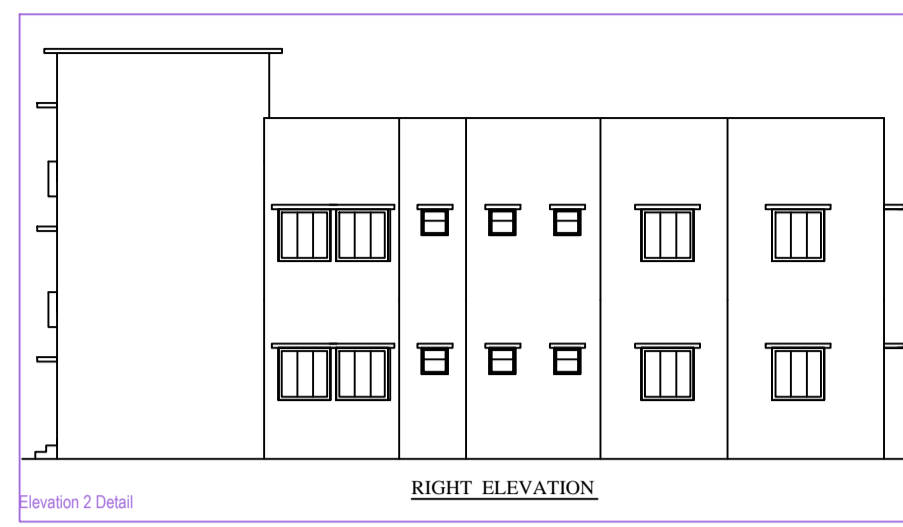
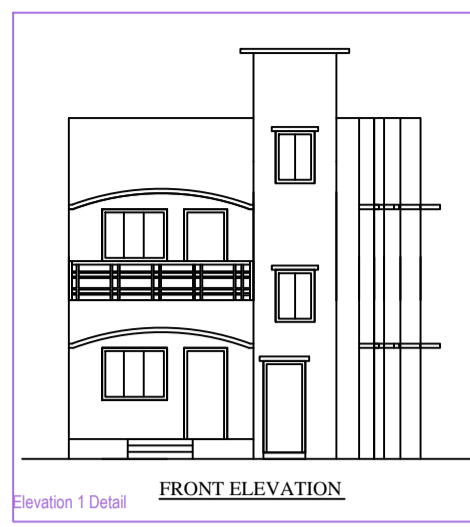

BRIEF SPECIFICATION

- FOUNDATION: RIGID DEPTH W/IDE P.C.C 140 X 140 ON 100
- R.C.C. COLUMN 140 X 140
- FLOORING: 125 MM THICK L.P.S FLOORING
- ROOFING: 125 MM THICK R.C.C SLAB
- WALL: WOOD DOOR & WOOD
- PLASTERING: 12.5 MM THICK
- PAINTING: OIL BASE PAINT

DRIVER: OWNER
ENGINEER: ARCHITECT

PROJECT DETAILS	
Project No.	PK/2024/001
Project Name	Residential Building
Client Name	Pravin Kumar Singh
Location	Plot No. 12, Sector 15, Gurgaon, Haryana
Area	1200 Sq. Mtr.
Volume	12000 Cu. Mtr.
Height	10 Mtr.
Orientation	North
Scale	1:100
Author	Pravin Kumar Singh
Check	Pravin Kumar Singh
Date	15/10/2024

COLOR INDEX	
PLOT BOUNDARY	Red
EXISTING ROAD	Green
PROPOSED WORK (COVERAGE AREA)	Blue
EXISTING (To be retained)	Yellow
EXISTING (To be demolished)	Black

MARGIN DETAIL	
Building / Wing	Front Margin
PK BUILDING	3.15
Building / Wing	Rear Margin
PK BUILDING	1.80
Building / Wing	Side Margin
PK BUILDING	0.90
Building / Wing	Setback Margin
PK BUILDING	0.90

FAR & Tenement Details (Table 4c-1)					
Building	No. of Store	Total Built Up Area (Sq. Mtr.)	Setback Area (Sq. Mtr.)	Proposed FAR Area (Sq. Mtr.)	Total FAR Area (Sq. Mtr.)
PK BUILDING	1	272.65	1.34	266.66	266.66
Grand Total	1	272.65	1.34	266.66	266.66

Building PK (BUILDING)

Floor Name	Total Built Up Area (Sq. Mtr.)	Deduction Area (Sq. Mtr.)	Proposed FAR Area (Sq. Mtr.)	Total FAR Area (Sq. Mtr.)	Tent. (%)
Ground Floor	136.33	2.37	133.33	133.33	01
First Floor	136.33	2.37	133.33	133.33	01
Terrace Floor	1.99	0.99	1.00	1.00	01
Total	272.65	5.73	266.66	266.66	01
Total Number of Store Buildings	1				
Total	272.65	5.73	266.66	266.66	01

SCHEDULE OF JOINERY:

BUILDING NAME	NAME	LENGTH	HEIGHT	NO. OF STORES
PK BUILDING	D	6.50	2.10	08
PK BUILDING	W	1.00	2.10	08
PK BUILDING	W	1.00	2.10	08
Total				24

SCHEDULE OF JOINERY:

BUILDING NAME	NAME	LENGTH	HEIGHT	NO. OF STORES
PK BUILDING	V	6.50	1.00	08
PK BUILDING	W1	6.50	1.00	02
PK BUILDING	W2	6.50	1.00	02
PK BUILDING	W3	1.50	1.00	10
PK BUILDING	W	1.50	1.00	08
PK BUILDING	W4	1.00	1.00	02
Total				28

UnitBUA Table for Building PK (BUILDING)

FLOOR	Name	UnitBUA Type	UnitBUA Area	Capex Area	No. of Rooms	No. of Tenement
GROUND FLOOR	SPLIT PK	FLAT	220.72	213.63	13	1
1ST FLOOR			220.72	213.63	24	1

