

Proposal Basic Information

Proposal File No.	MADA/BP/0051/2021
Owner Name	SMT. MRIDULA SINHA
Khata No	OLD KHATA NO-69,NEW KHATA NO-134
Plot No	OLD PLOT NO. 495, NEW PLOT NO. 1444
Village Name	Jalgora
Use	Residential
SubUse	Bungalow/ Dwelling / Non Apartment

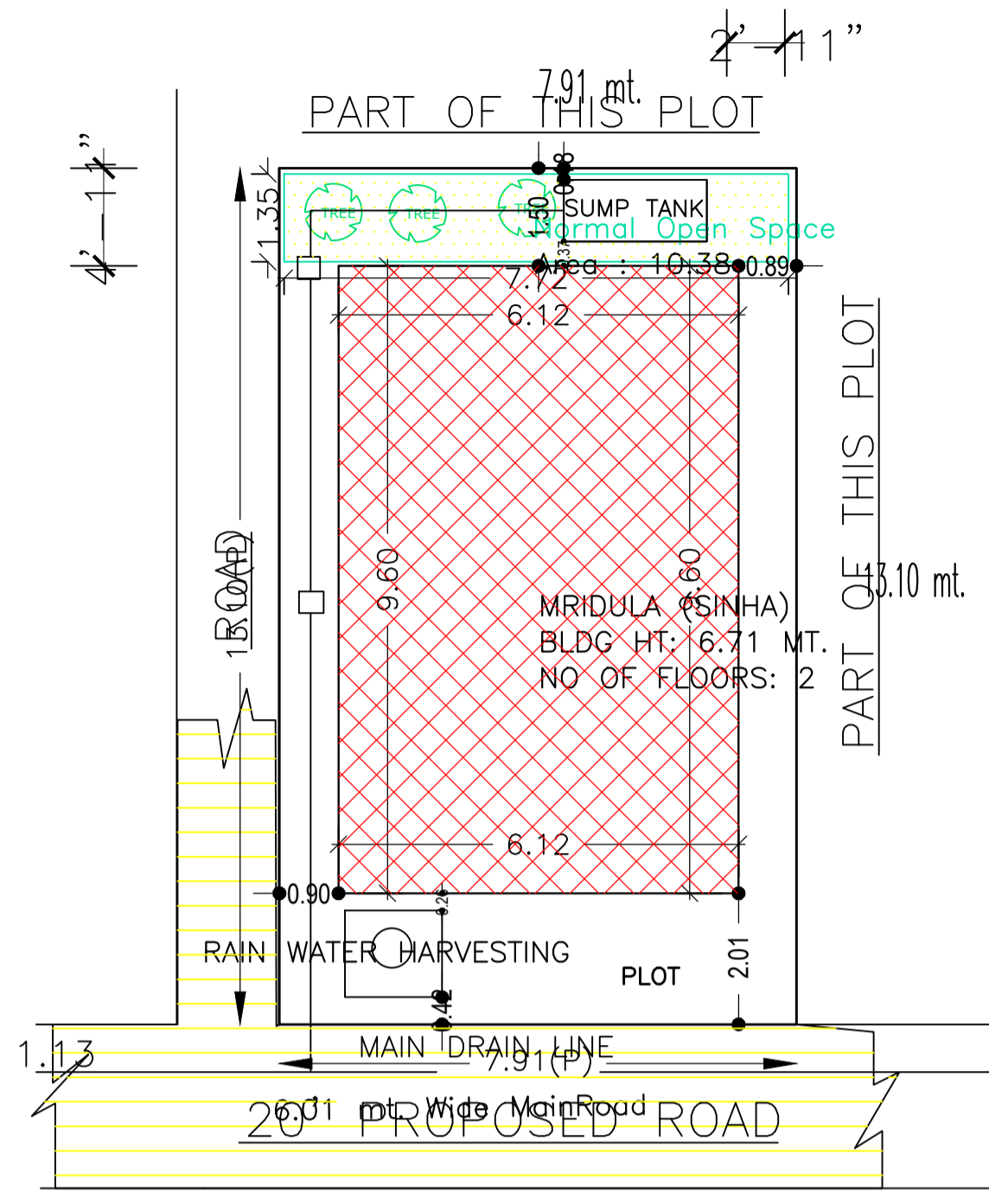

SITE PLAN
SCALE - 1" = 16'-0"

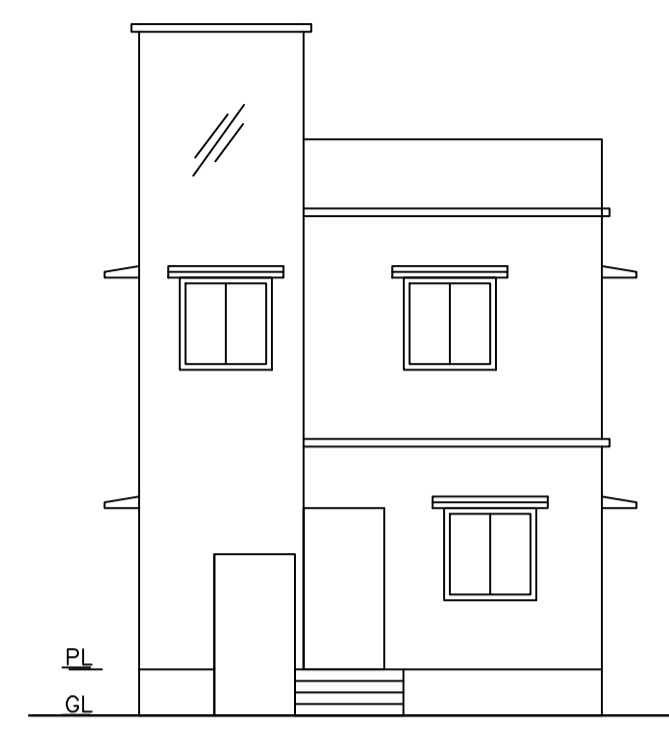

FRONT ELEVATION
SCALE - 1" = 8'-0"

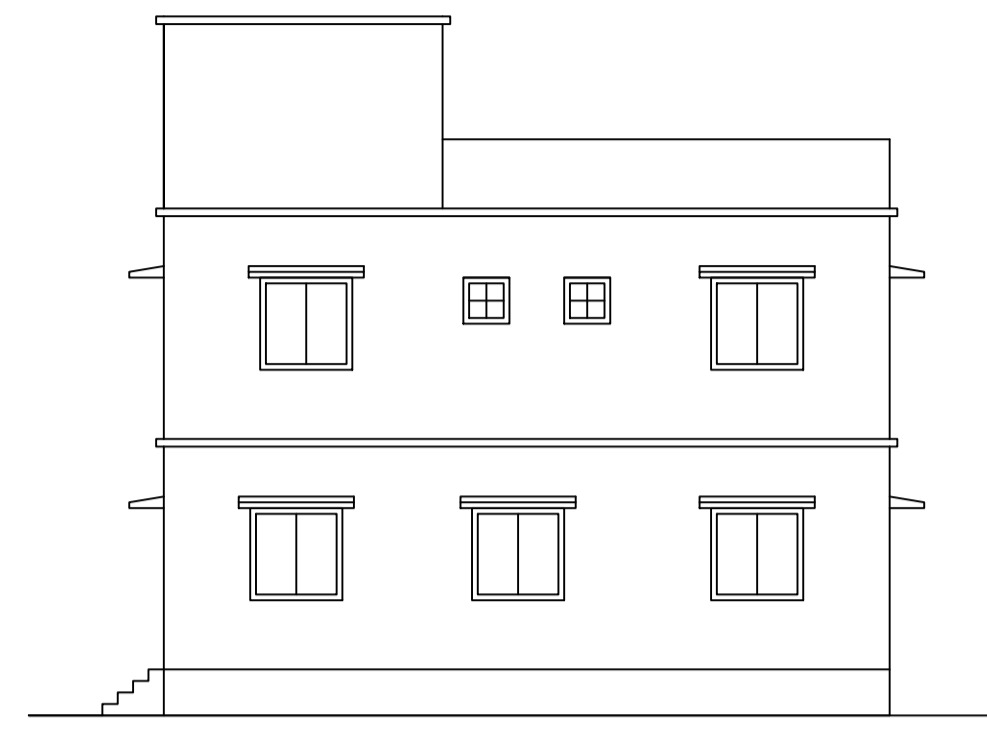

RIGHT SIDE ELEVATION
SCALE - 1" = 8'-0"

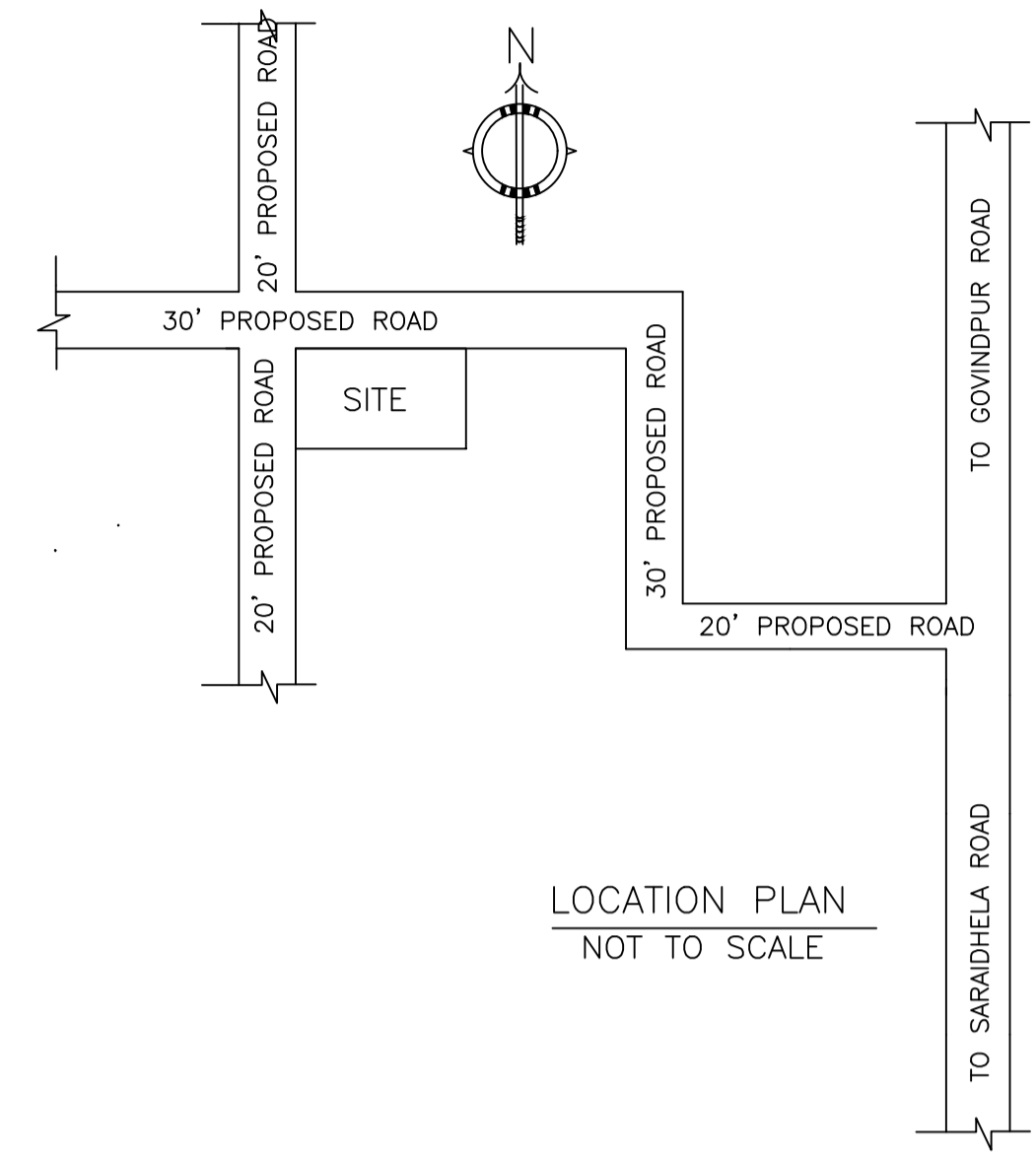

LOCATION PLAN
NOT TO SCALE

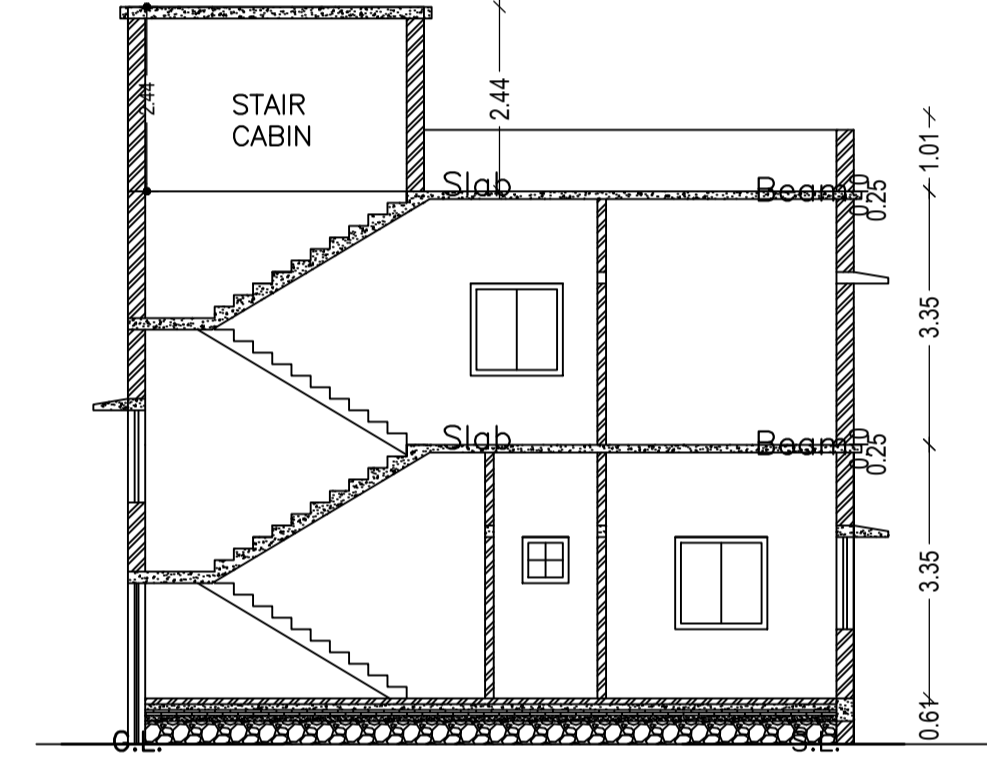

SECTION - XX'
SCALE - 1" = 8'-0"

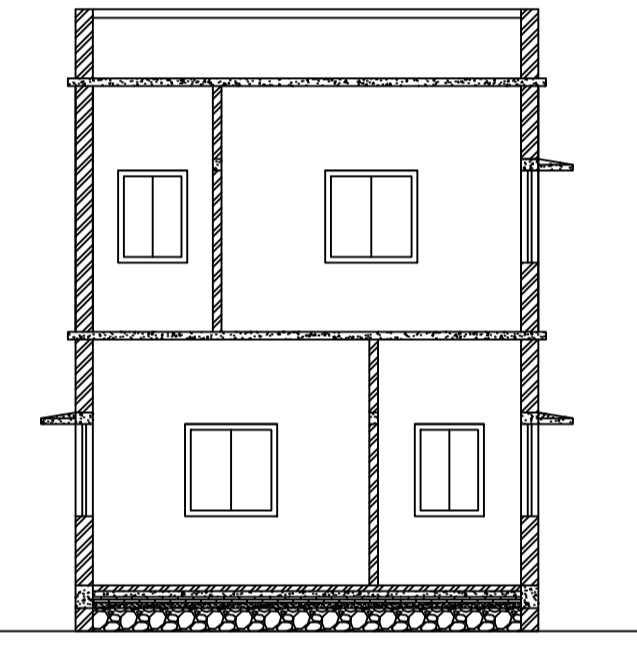

SECTION - YY'
SCALE - 1" = 8'-0"

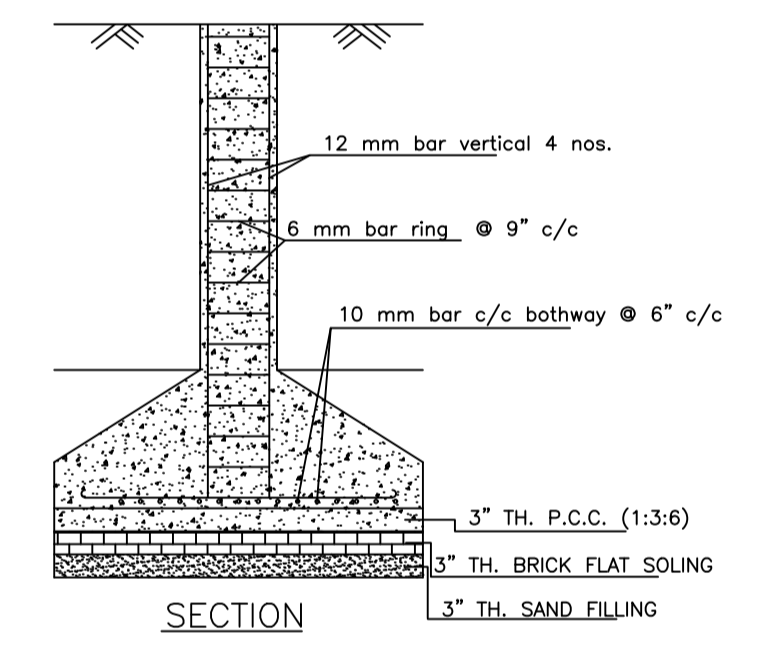

SECTION

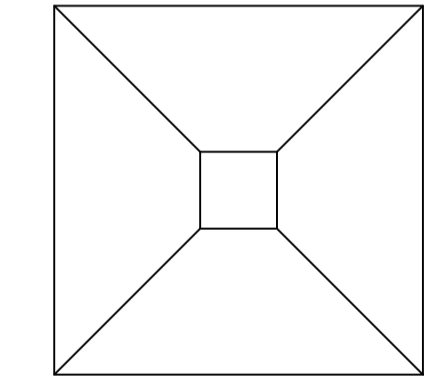

PLAN

DETAILS OF COLUMN FOUNDATION
SCALE - 1" = 2'-0"

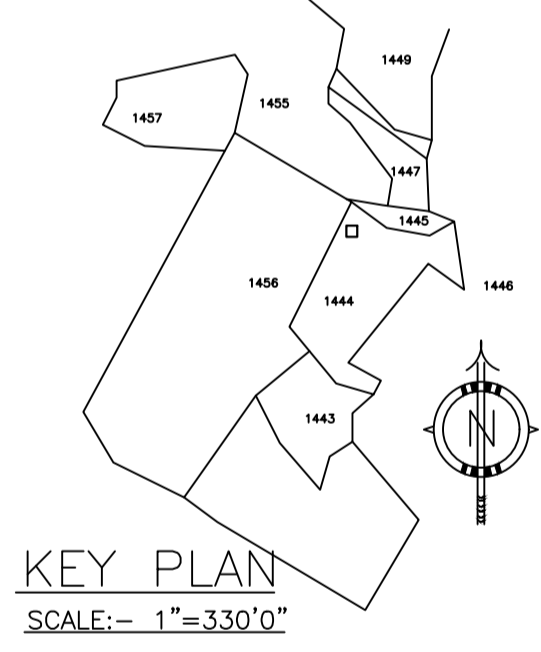

KEY PLAN
SCALE:- 1"=330'0"

SCHEDULE OF DOOR:

BUILDING NAME	NAME	LENGTH	HEIGHT	NOS
MRIDULA (SINHA)	D	0.76	2.10	03
MRIDULA (SINHA)	D	0.91	2.10	02
MRIDULA (SINHA)	D	1.07	2.10	04

SCHEDULE OF WINDOW/VENTILATION:

BUILDING NAME	NAME	LENGTH	HEIGHT	NOS
MRIDULA (SINHA)	w	0.61	1.20	03
MRIDULA (SINHA)	w	0.91	1.20	02
MRIDULA (SINHA)	w	1.22	1.20	12

Building :MRIDULA (SINHA)

Floor Name	Total Built Up Area (Sq.mt.)	Proposed FAR Area (Sq.mt.) Resi.	Total FAR Area (Sq.mt.)	Total Consumed Additional FAR Area (Sq.mt.)	Tnmt (No.)
Ground Floor	58.77	58.77	58.77	58.77	01
First Floor	58.77	58.77	58.77	58.77	00
Terrace Floor	0.00	0.00	0.00	0.00	00
Total :	117.54	117.54	117.54	117.54	01
Total Number of Same Buildings :	1				
Total :	117.54	117.54	117.54	117.54	01

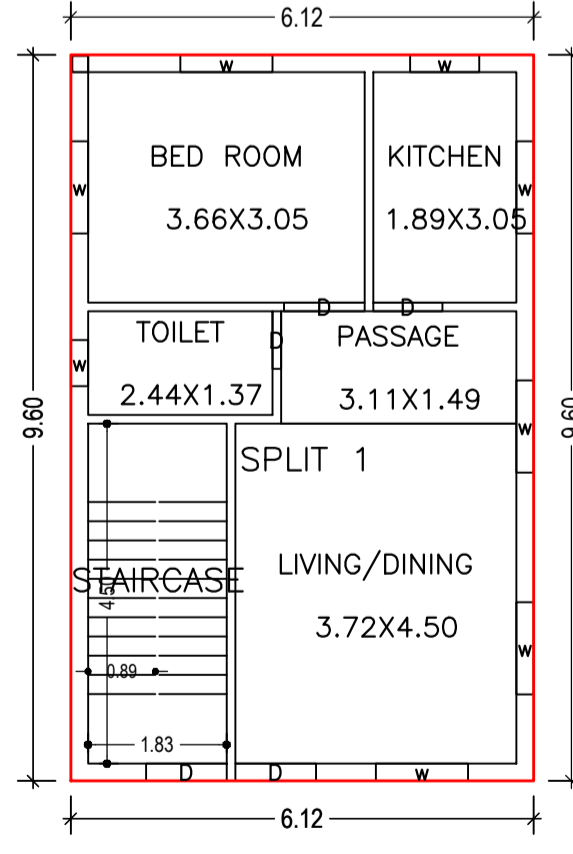

GROUND FLOOR PLAN (Proposed)
SCALE 1:100

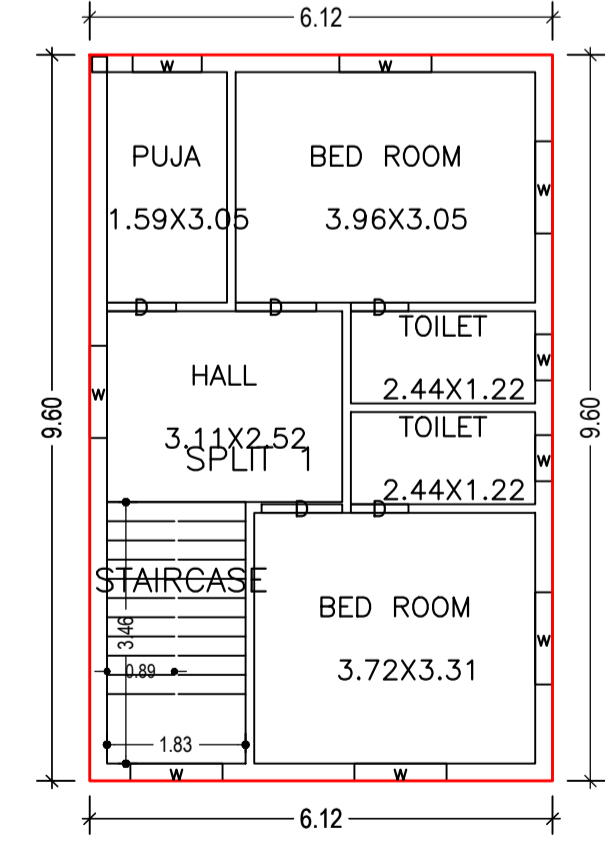

FIRST FLOOR PLAN (Proposed)
SCALE 1:100

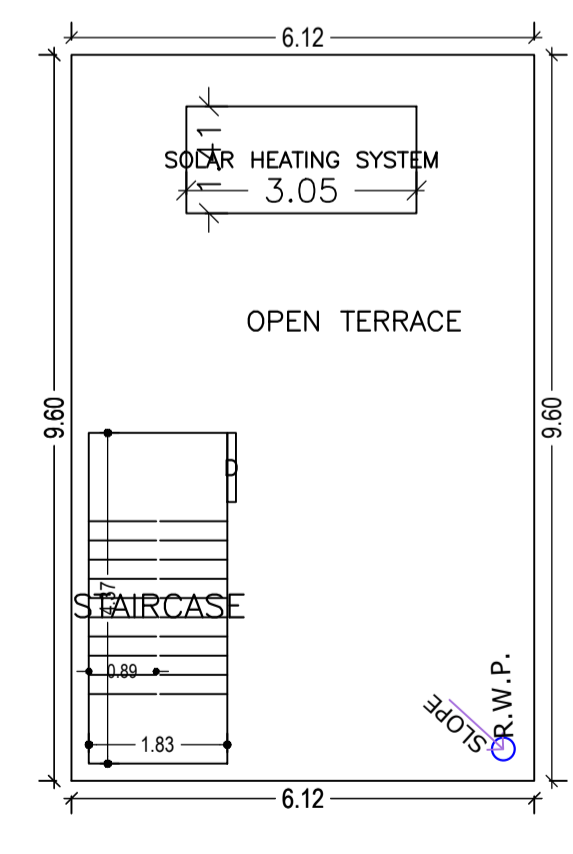

TERRACE FLOOR PLAN (SCALE 1:100)

AREA STATEMENT MINERAL AREA DEVELOPMENT AUTHORITY	VERSION NO. : 1.0.55	VERSION DATE: 16/10/2020
PROJECT DETAIL:		
Region: JHARKHAND URBAN LOCAL BODIES	Plot Use: Residential	
District: DHANBAD	Plot SubUse: Bungalow/ Dwelling / Non Apartment	
Authority: MINERAL AREA DEVELOPMENT AUTHORITY	PlotNearby/ReligiousStructure: NA	
Inward No: MADA/BP/0051/2021	Plot/SubPlot No: OLD PLOT NO. 495, NEW PLOT NO. 1444	
Application Type: General Proposal	North: Road Width - 6.01	
Project Type: Building Permission	South: Plot No. - SAME PLOT	
Nature of Development: New	East: Plot No. - SAME PLOT	
Location of Development Area: Old Area	West: Road Width - 6.1	
AREA DETAILS:		
AREA OF PLOT (Minimum)	(A)	103.69
NET AREA OF PLOT(Gross Plot Area - Deduction from Gross Plot area)	(A-Deductions)	103.69
Deduction for Balance Plot Area(from Gross Plot Area)		
Common Plot		10.38
Total		10.38
BALANCE AREA OF PLOT(Net Plot Area - Recreational/Amenity space)	(A-Deductions)	93.31
PLOT AREA FOR COVERAGE(Net Plot Area)	(A-Deductions)	103.69
Plot Area for FAR (Net Plot Area + Road Widening Area)	(A-Deductions)	103.69
COVERAGE CHECK		
Permissible Coverage area (70.00 %)		72.58
Proposed Coverage Area (56.68 %)		58.77
Total Prop. Coverage Area (56.68 %)		58.77
Balance coverage area (13.32 %)		13.81
FAR CHECK		
Perm. FAR Area (1.80)		186.64
Total Perm. FAR area		186.64
Residential FAR		117.55
Proposed FAR Area		117.55
Total Proposed FAR Area		117.55
Consumed FAR (Factor)		1.13
Balance FAR Area		69.09
BUILT UP AREA CHECK		
Total Proposed BuiltUp Area		117.54
ARCHITECT (Regd)		
ENGINEER (Regd)		RAM PRATAP SINGH
SUPERVISOR (Regd)		
OWNER (Regd)		SMT. MRIDULA SINHA
DEVELOPMENT AUTHORITY		
		LOCAL BODY

COLOR INDEX	
PLOT BOUNDARY	Black
ABUTTING ROAD	Green
PROPOSED CONSTRUCTION	Red
COMMON PLOT	Yellow
ROAD WIDENING AREA	Blue
EXISTING (To be retained)	Blue
EXISTING (To be demolished)	Yellow

Floor Name	Building Name		Total	
	Proposed Built Up Area (Sq.mt.)	Proposed FAR Area (Sq.mt.)	Total Proposed Built Up Area (Sq.mt.)	Total FAR Area (Sq.mt.)
Ground Floor	58.77	58.77	58.77	58.77
First Floor	58.77	58.77	58.77	58.77
Terrace Floor	0.00	0.00	0.00	0.00
Total :	117.54	117.54	117.54	117.54

Building Name	Building Use	Building SubUse	Building Structure
MRIDULA (SINHA)	Residential	Residential Bldg/Apartment	Non-Highrise

Building	No. of Same Bldg	Total Built Up Area (Sq.mt.)	Proposed FAR Area (Sq.mt.) Resi.	Total FAR Area (Sq.mt.)	Total Consumed Additional FAR Area (Sq.mt.)	Tnmt (No.)
MRIDULA (SINHA)	1	117.54	117.54	117.54	117.54	01
Grand Total :	1	117.54	117.54	117.54	117.54	01

UnitBUA Table for Building :MRIDULA (SINHA)

FLOOR	Name	UnitBUA Type	UnitBUA Area	Carpet Area	No. of Rooms	No. of Tenement
GROUND FLOOR PLAN	SPLIT 1	FLAT	117.55	117.46	5	1
FIRST FLOOR PLAN	SPLIT 1	FLAT	0.00	0.00	6	0
Total:	-	-	117.55	117.46	11	1

LTP NAME AND SIGNATURE	STRUCTURAL ENG'S NAME AND SIGNATURE	BUILDER NAME AND SIGNATURE	DIGITAL SIGNATURE
RAM PRATAP SINGH MADA/ARC/0024/2019			

Proposal Basic Information	
Proposal File No.	MADA/BP/0051/2021
Owner Name	SMT. MRIDULA SINHA
Khata No	OLD KHATA NO-69, NEW KHATA NO-134
Plot No	OLD PLOT NO. 495, NEW PLOT NO. 1444
Village Name	Jialgora
Use	Residential
SubUse	Bungalow/ Dwelling / Non Apartment

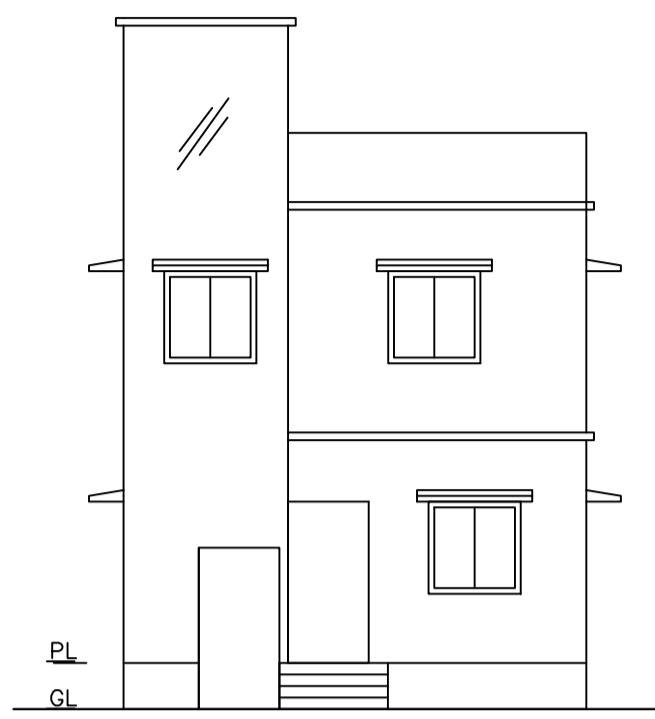

FRONT ELEVATION
SCALE - 1" = 8'-0"

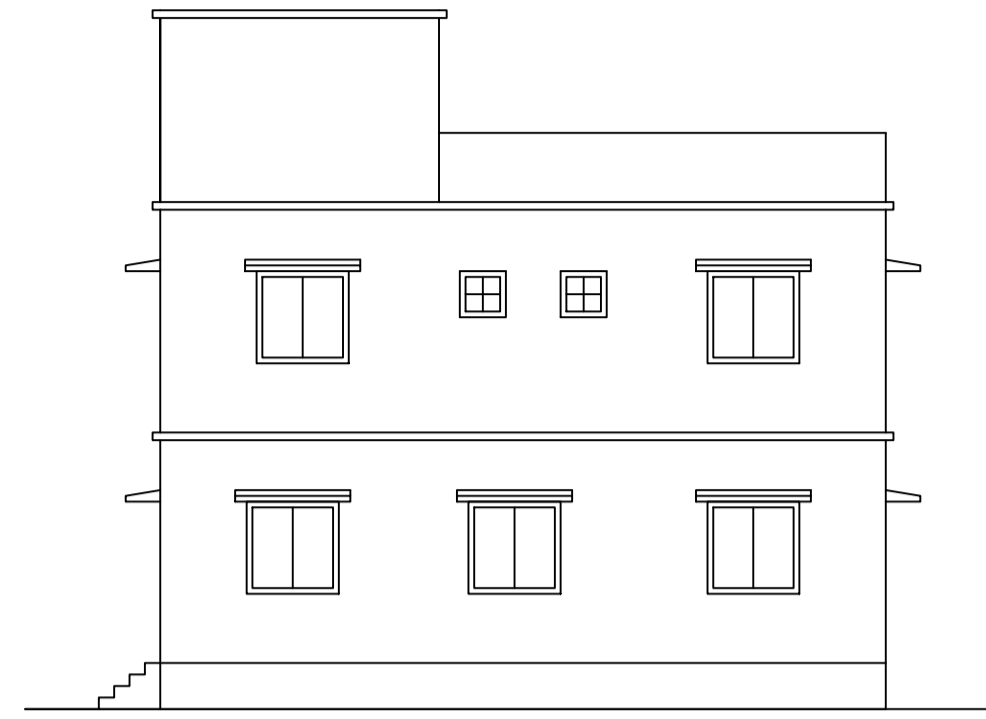

RIGHT SIDE ELEVATION
SCALE - 1" = 8'-0"

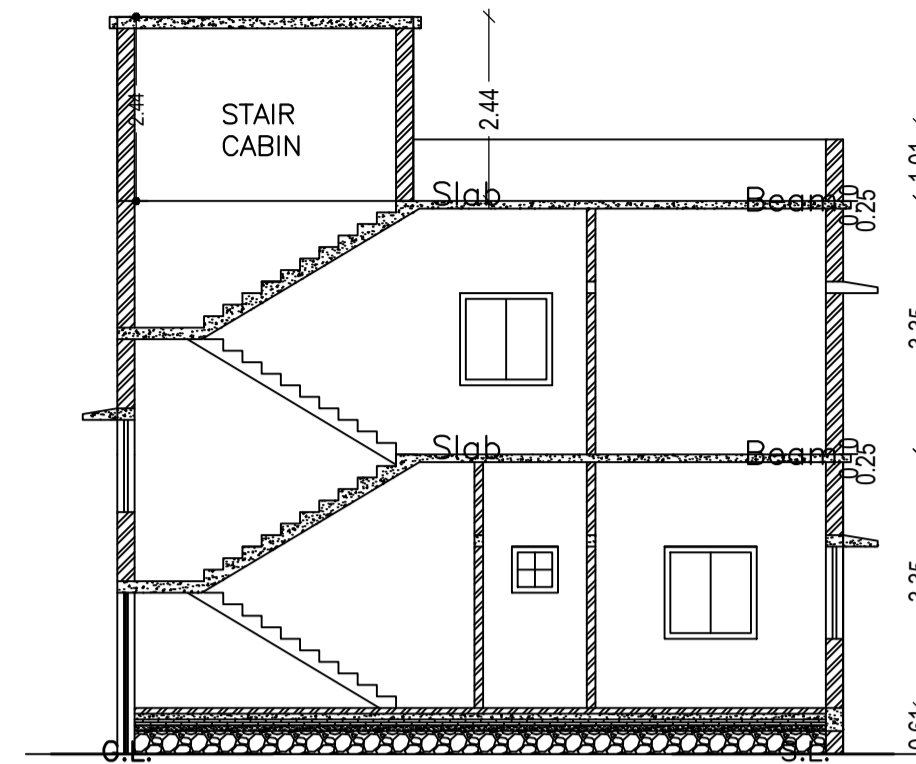

SECTION - XX'
SCALE - 1" = 8'-0"

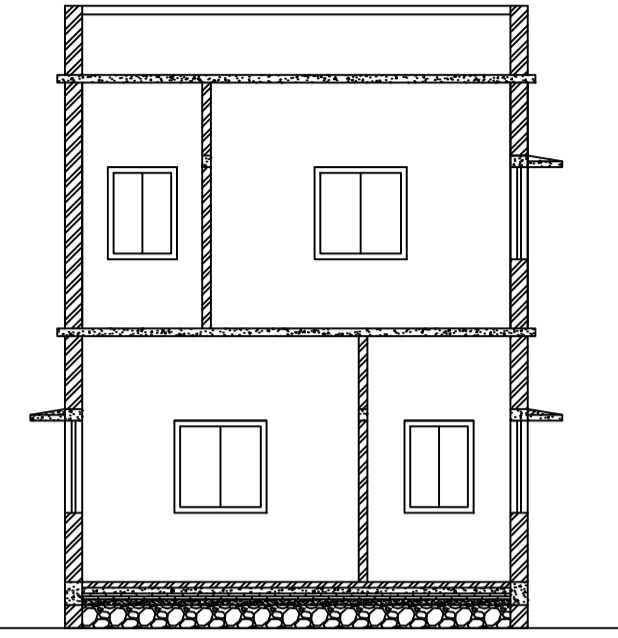

SECTION - YY'
SCALE - 1" = 8'-0"

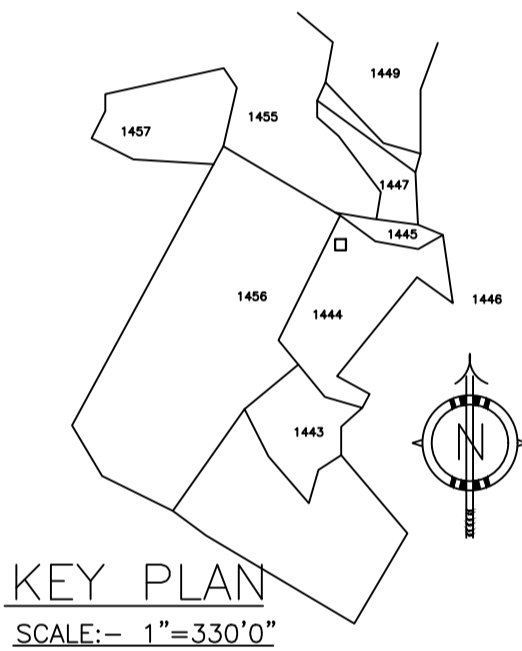

KEY PLAN
SCALE:- 1"=330'0"

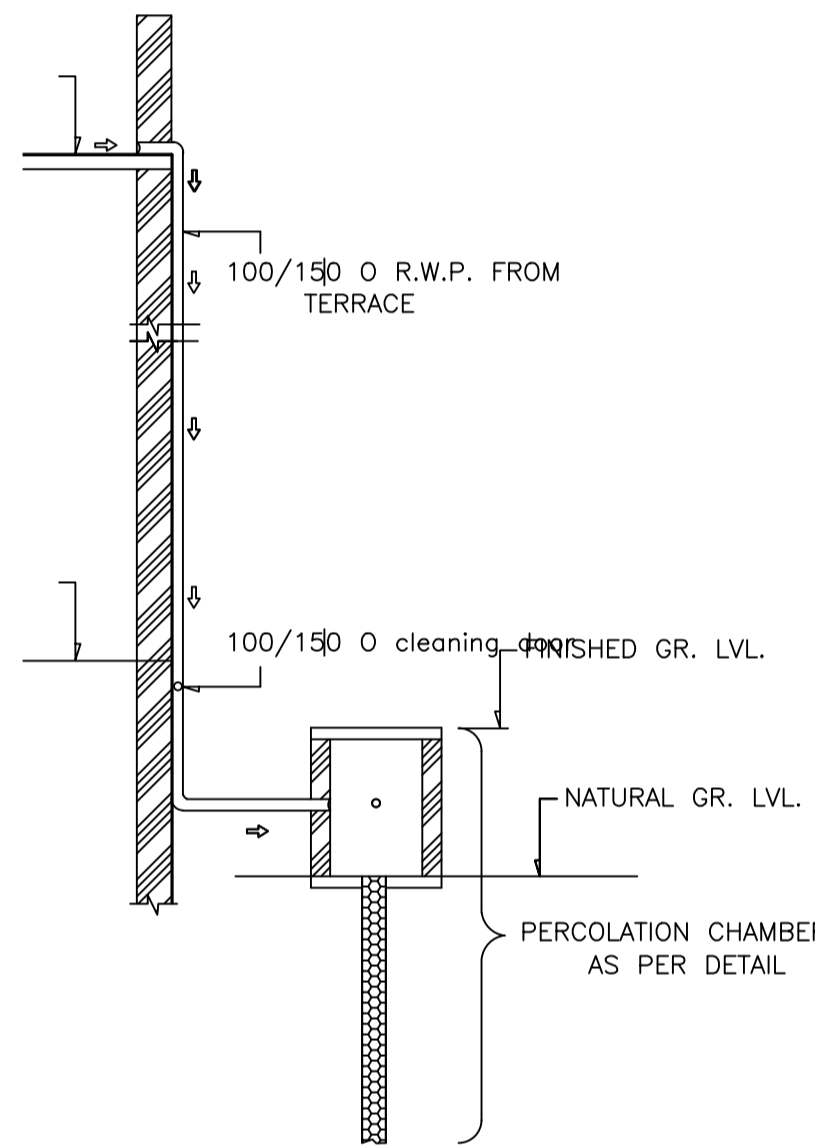

ROOF TOP RAIN WATER COLLECTION SYSTEM
SCALE = 1" = 4'-0"

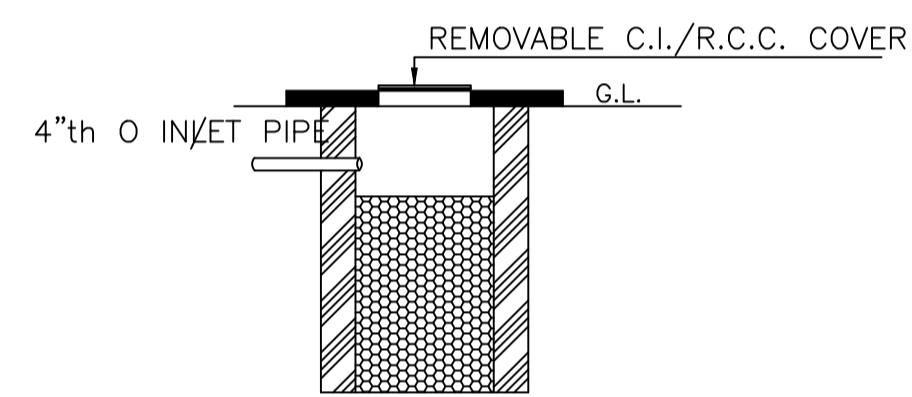

SECTION OF SOAK PIT

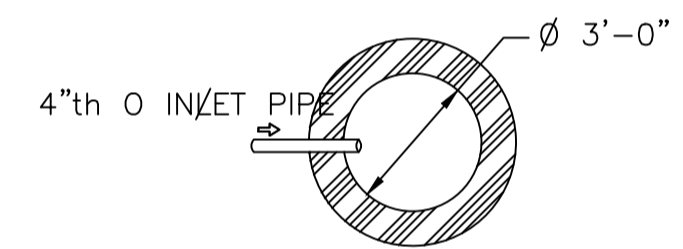

DETAILS OF SOAK PIT
SCALE = 1" = 2'-0"

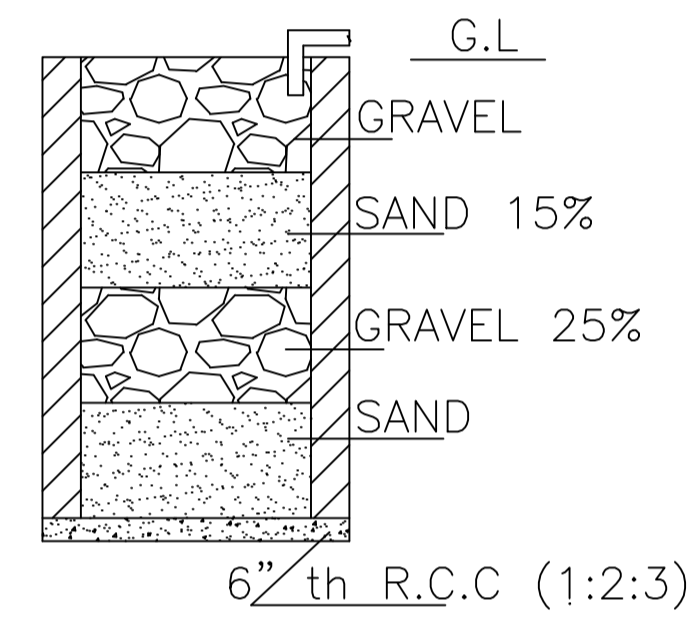

SECTION ON A - B

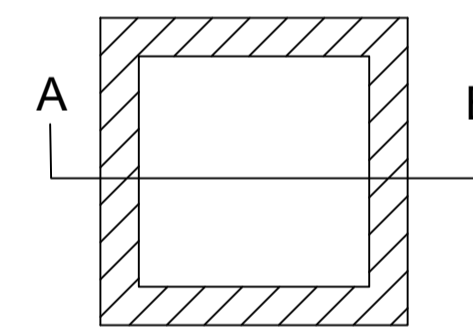

DETAILS DRAWING OF RAIN WATER HARVESTING

SCALE:- 1"=2'-0"

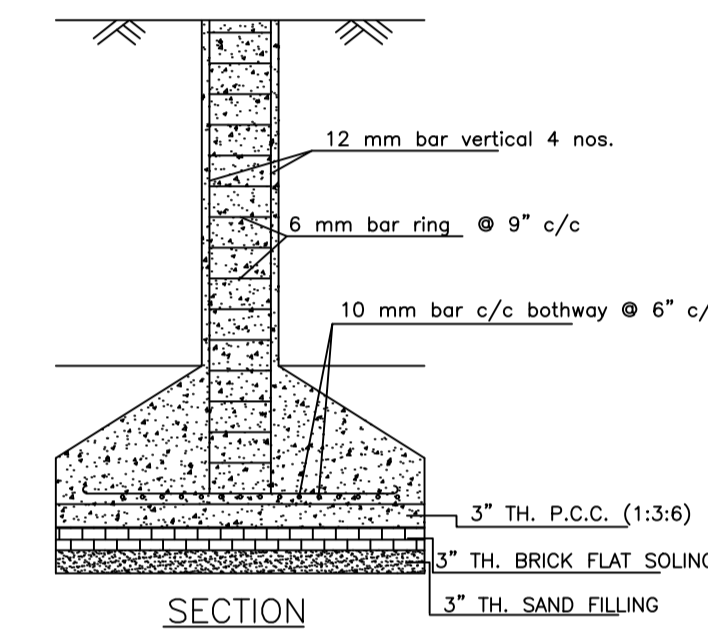

SECTION

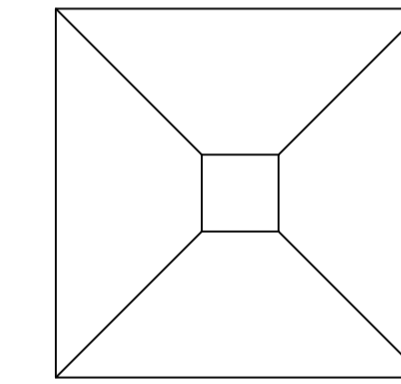

PLAN

DETAILS OF COLUMN FOUNDATION
SCALE - 1" = 2'-0"

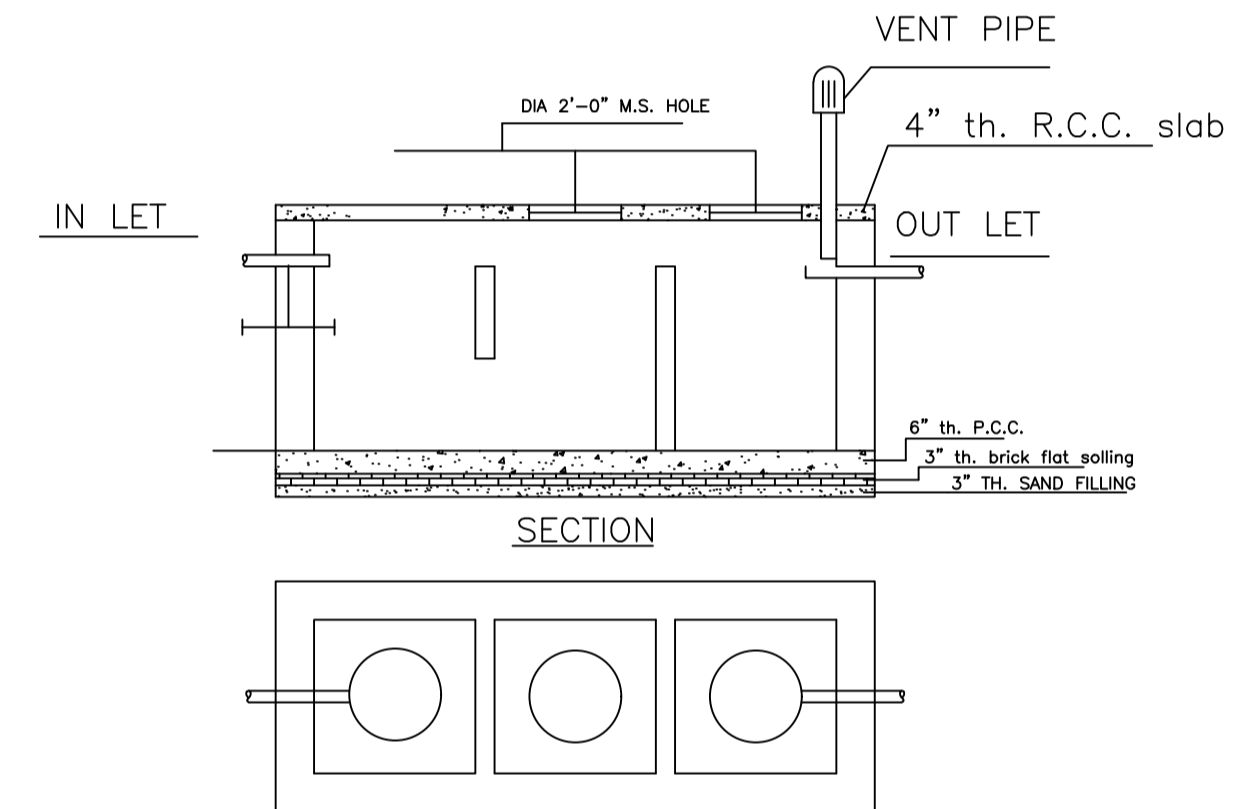

DETAILS OF SEPTIC TANK

SCALE - 1" = 4'-0"

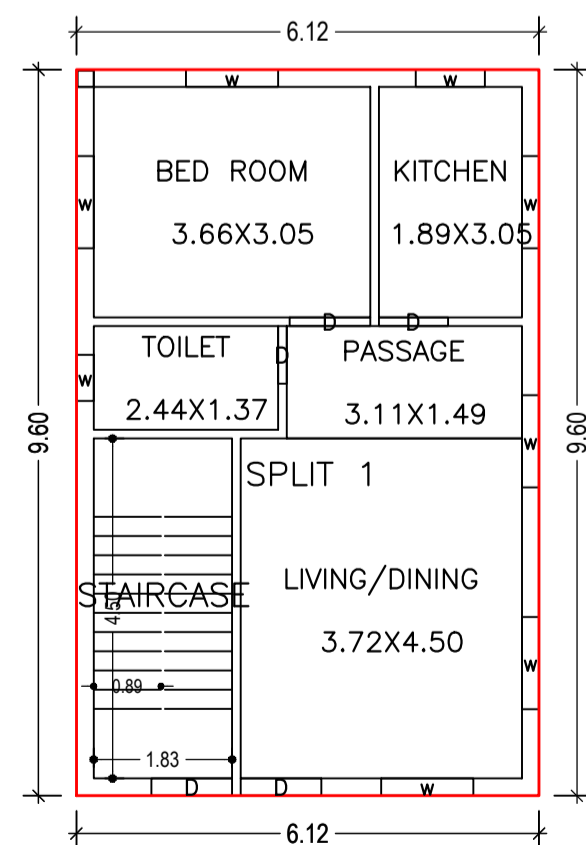

GROUND FLOOR PLAN
(Proposed)
(SCALE 1:100)

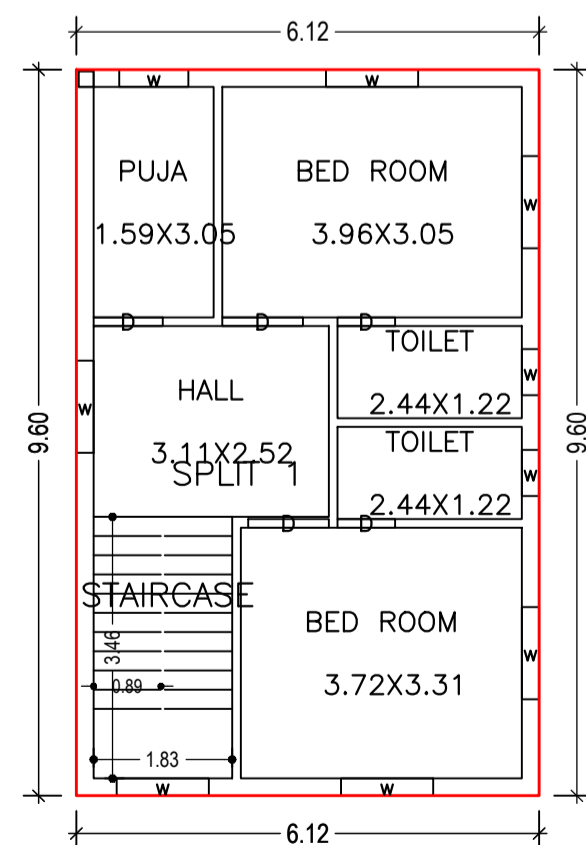

FIRST FLOOR PLAN
(Proposed)
(SCALE 1:100)

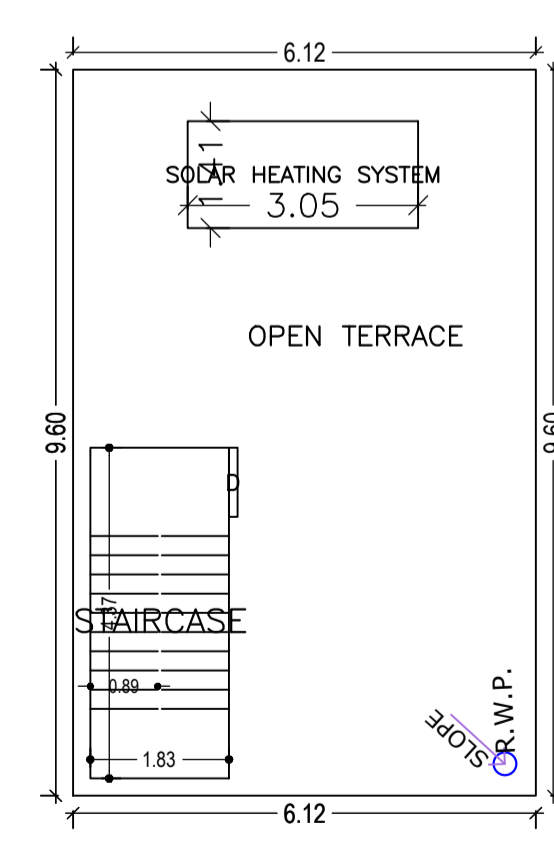

TERRACE FLOOR PLAN
(SCALE 1:100)

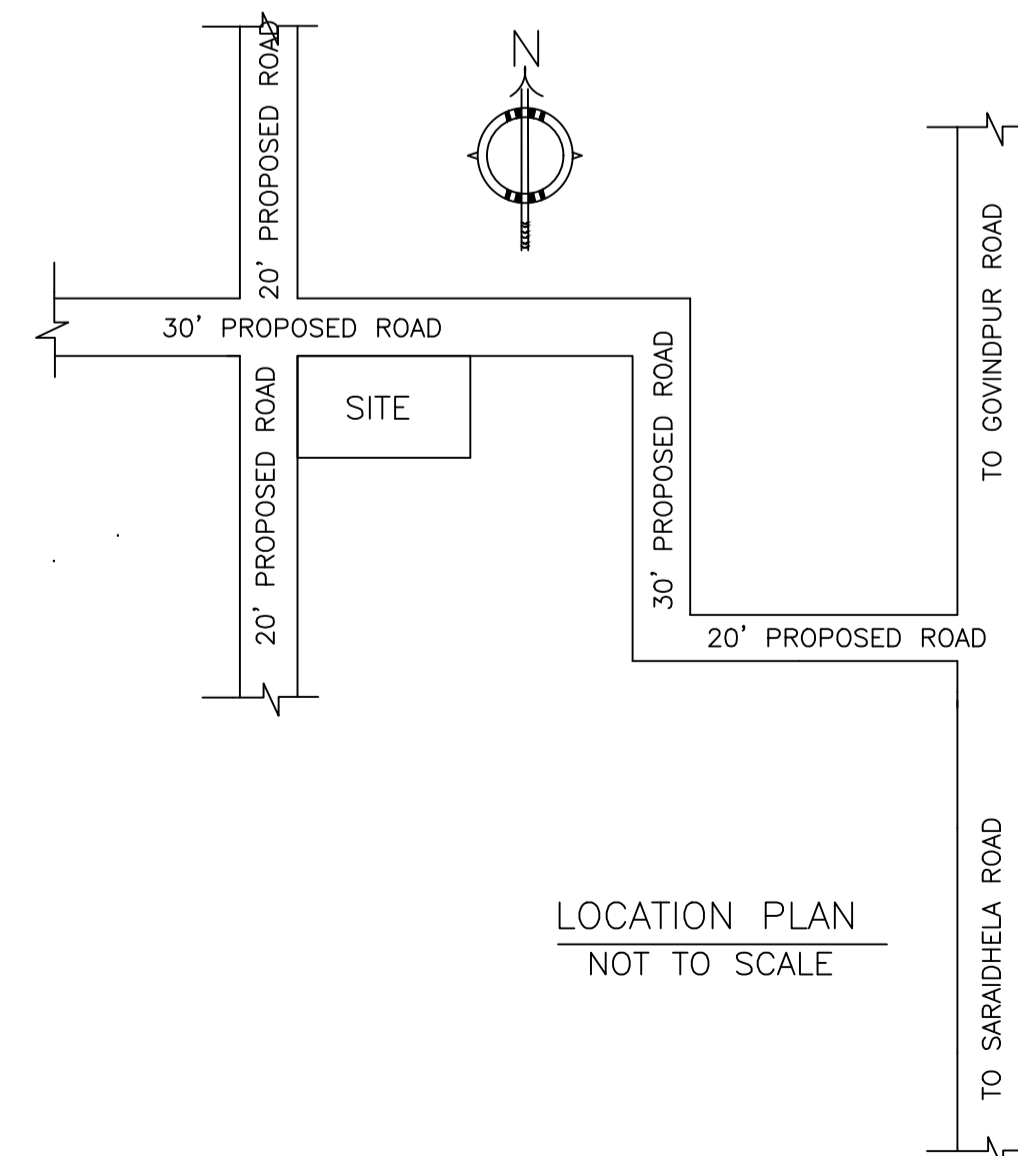

LOCATION PLAN
NOT TO SCALE

LTP NAME AND SIGNATURE	STRUCTURAL ENG'S NAME AND SIGNATURE	BUILDER NAME AND SIGNATURE	DIGITAL SIGNATURE
RAM PRATAP SINGH MADA/ARC/0024/2019			