

Proposal Basic Information

Proposal File No.	MADA/BP/0043/2021
Owner Name	SMT GEETA BARAT
Khata No	OLD - 04 & NEW - 251
Plot No	OLD - 1268 & NEW - 1445
Village Name	Damkara Barwaa
Use	Residential
SubUse	Bungalow/ Dwelling / Non Apartment

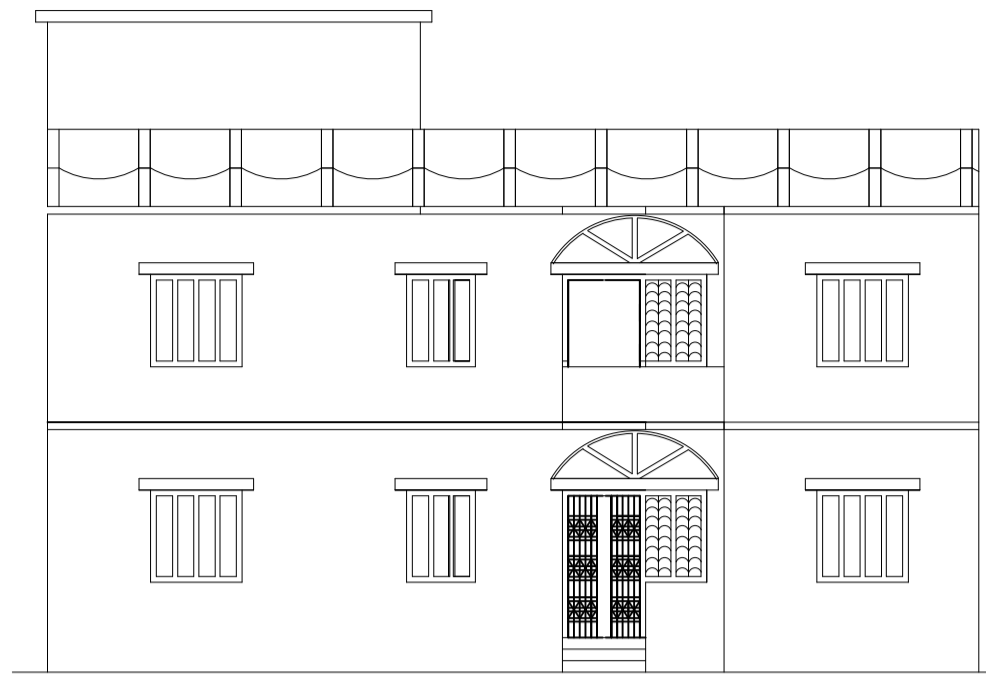

FRONT ELEVATION

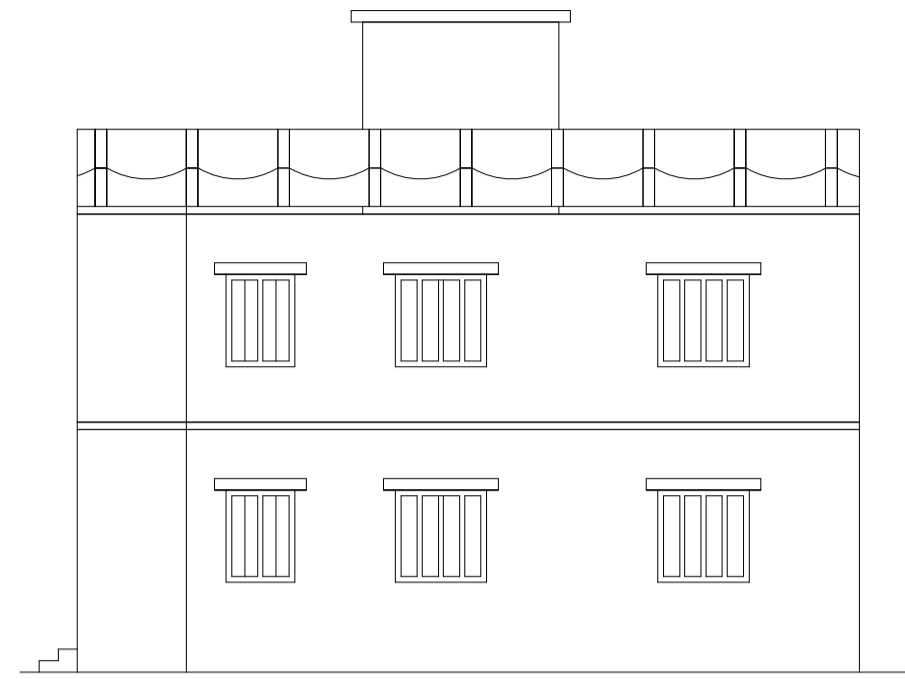

RIGHT SIDE ELEVATION

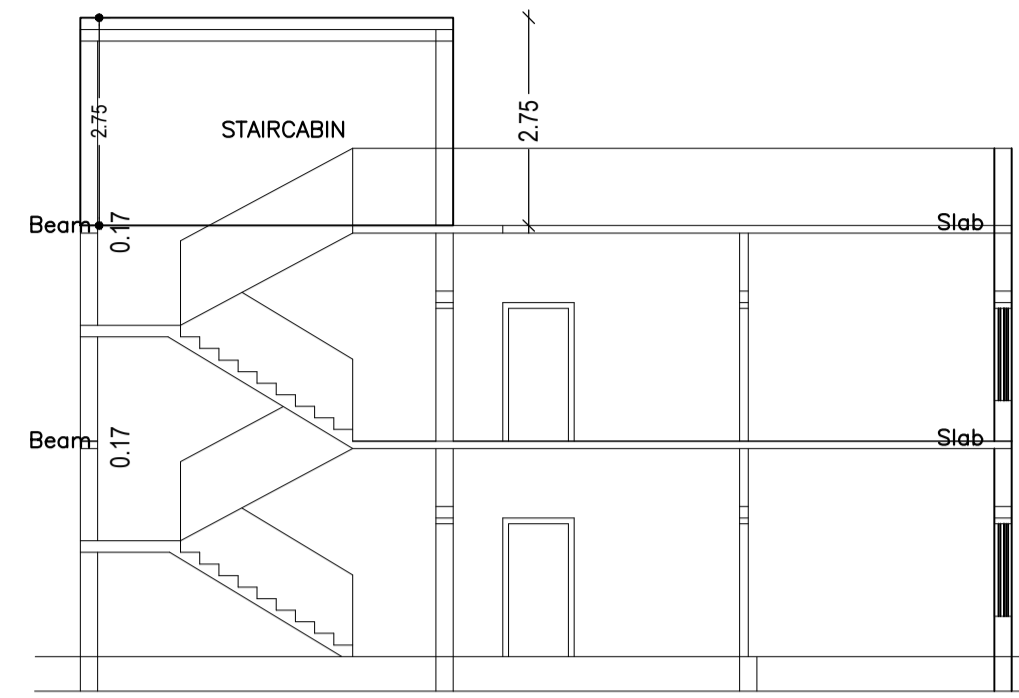

SECTION ON = X-X

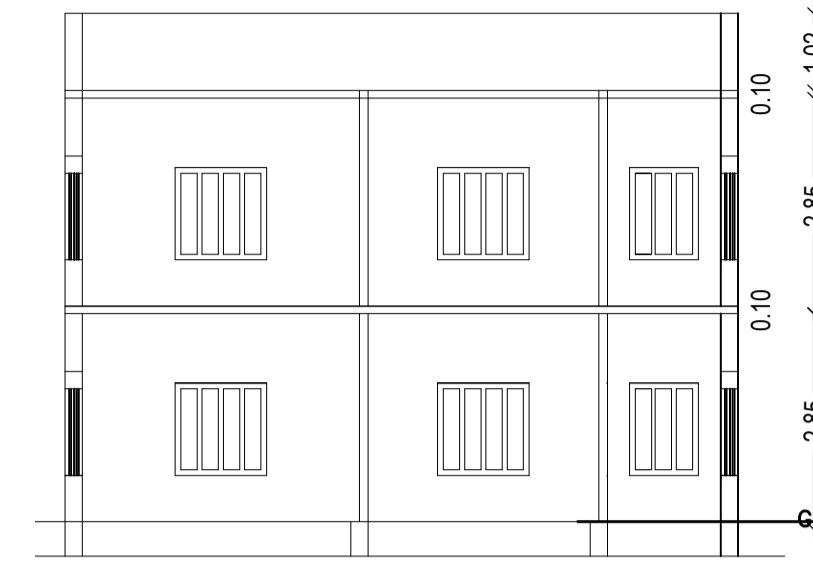

SECTION ON = Y-Y

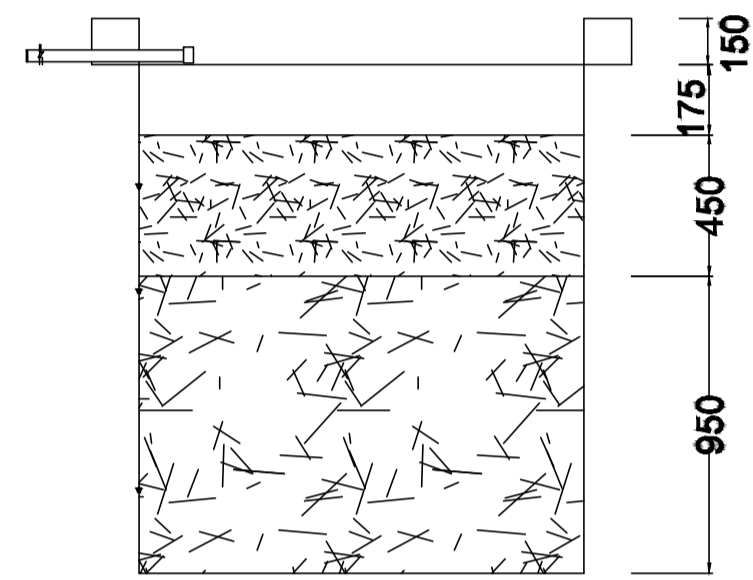

SECTION AT Y-Y

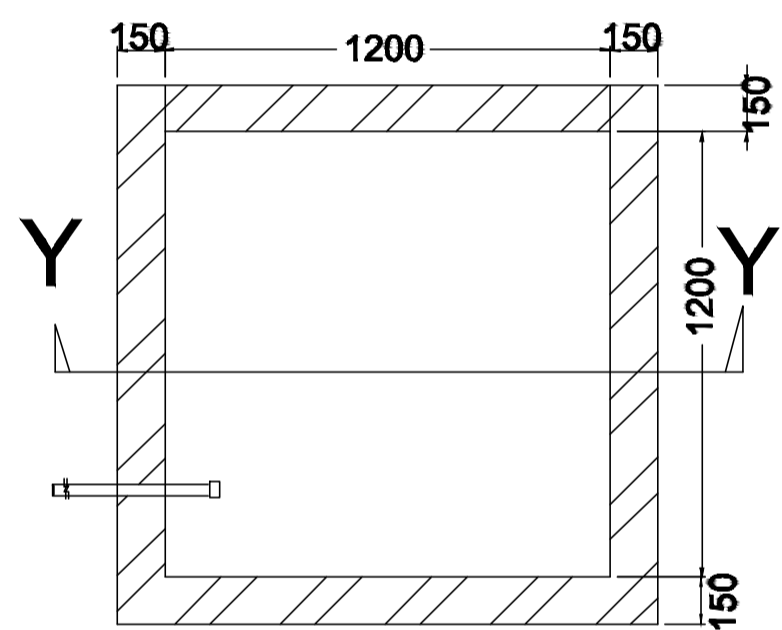

PLAN OF RECHARGE WELL

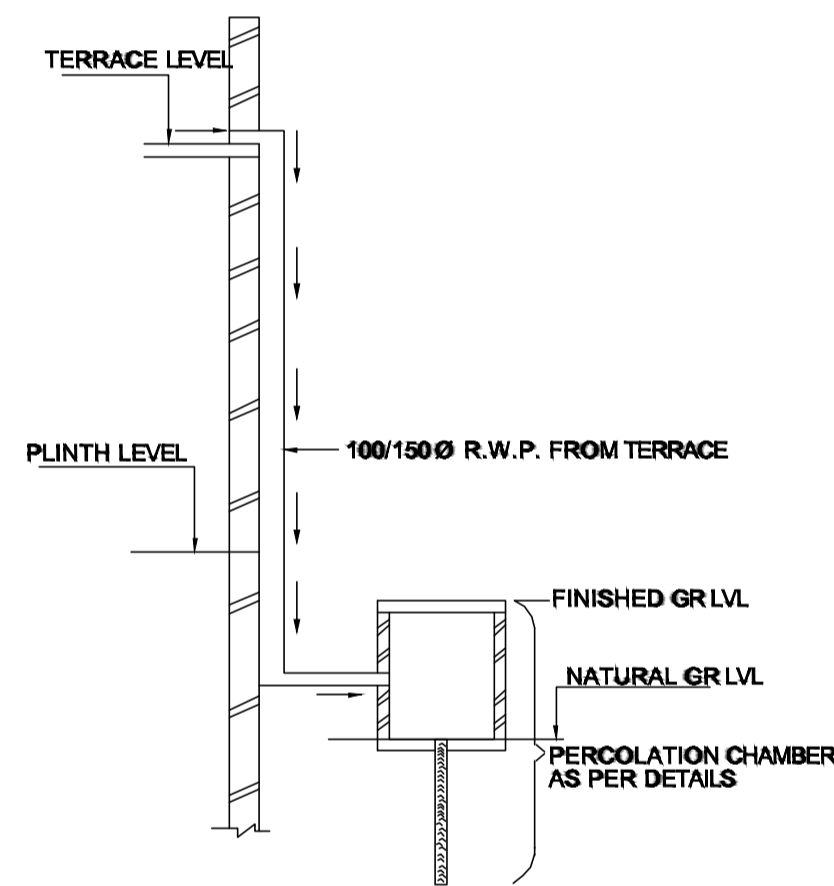

ROOF TOP RAIN WATER COLLECTION SYSTEM

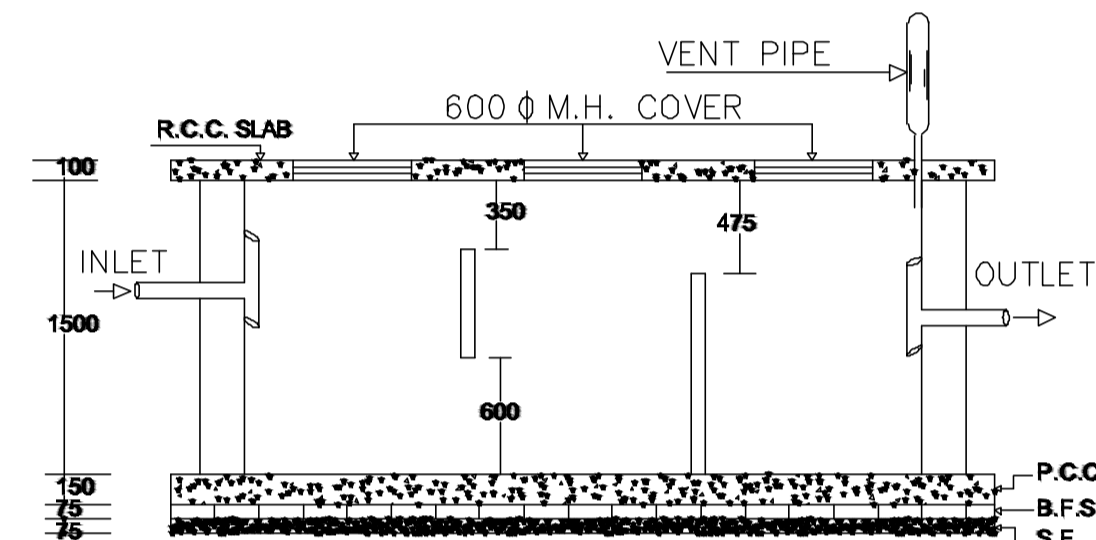

PLAN OF SEPTIC TANK

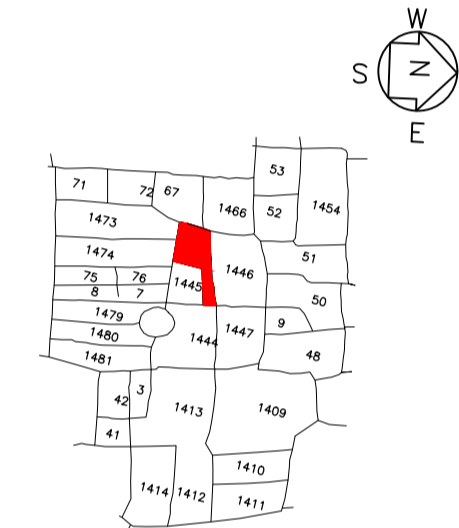

KEY PLAN
SCALE = NOT

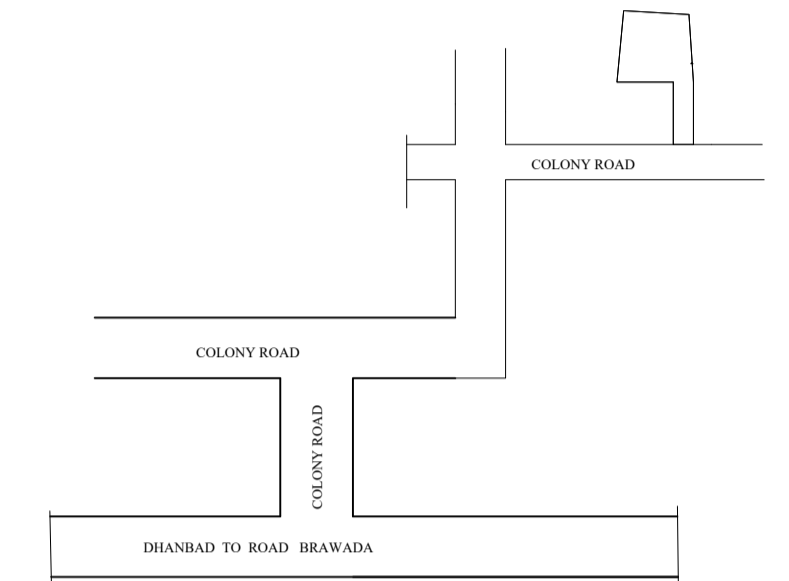

LOCATION PLAN
NOT TO SCALE

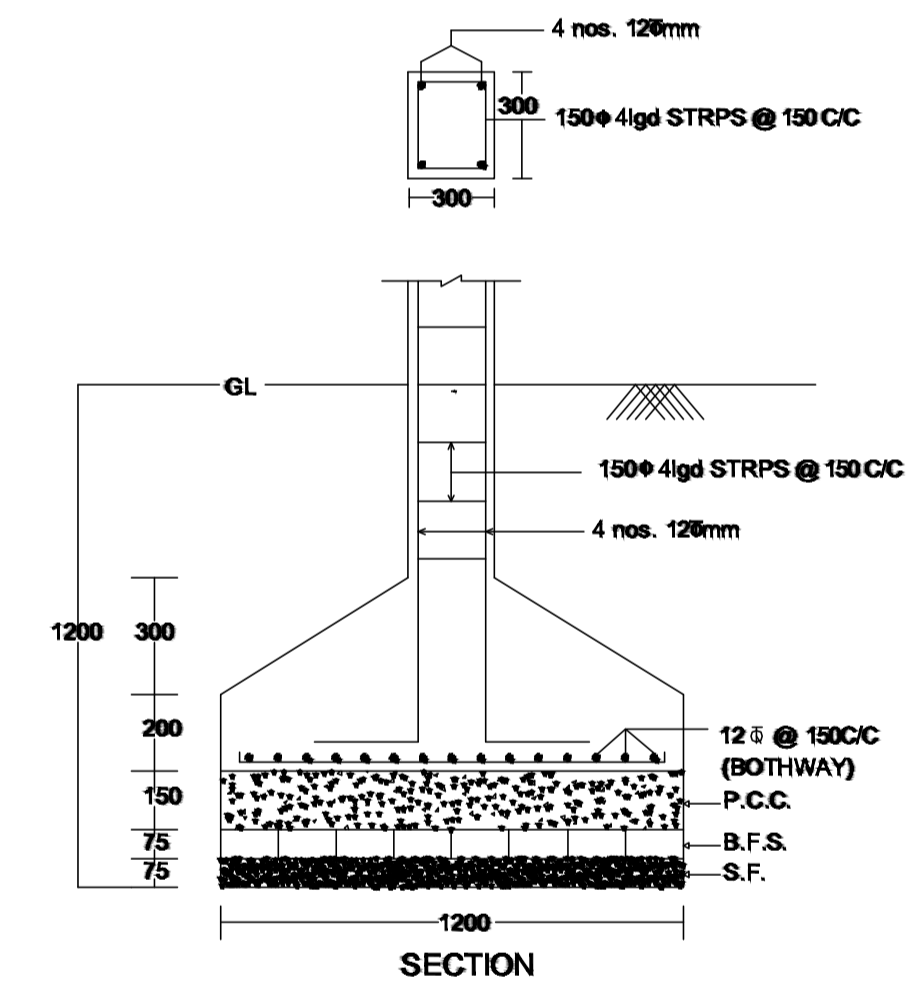

SECTION

WATER HARVESTING

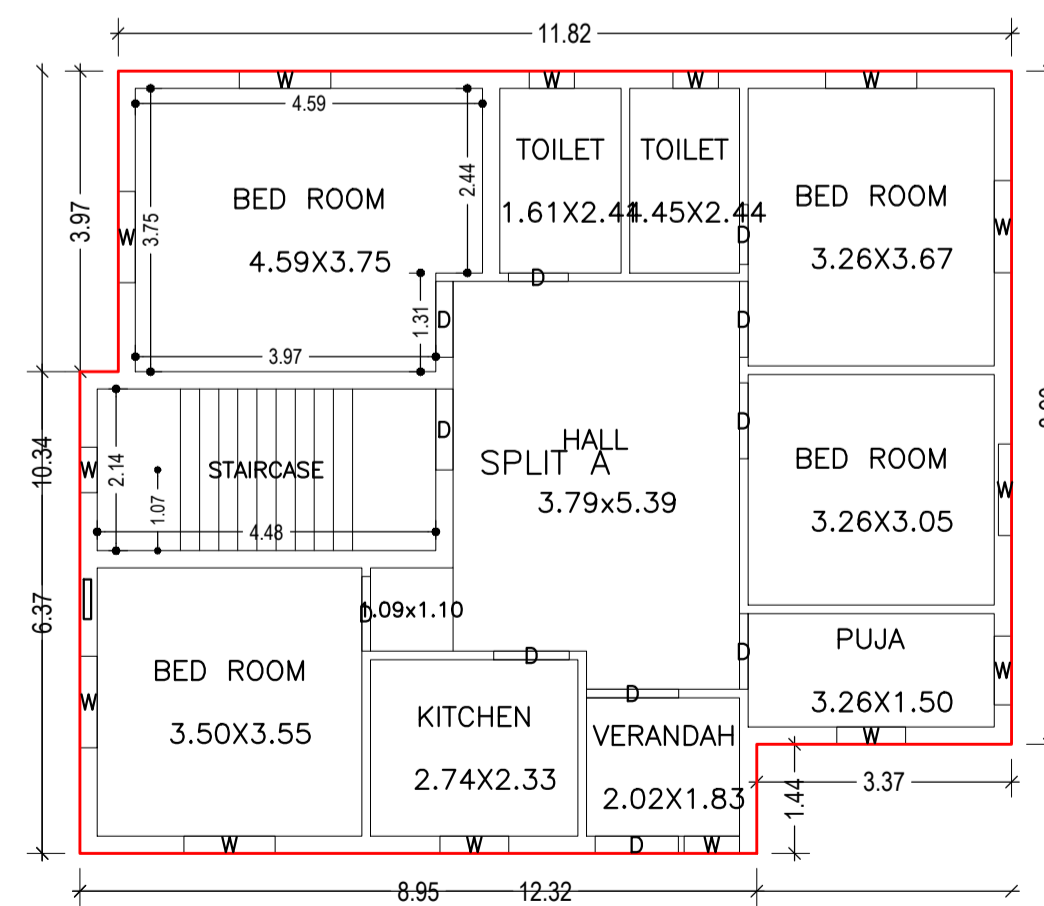

GROUND FLOOR PLAN
(Proposed)
(SCALE 1:100)

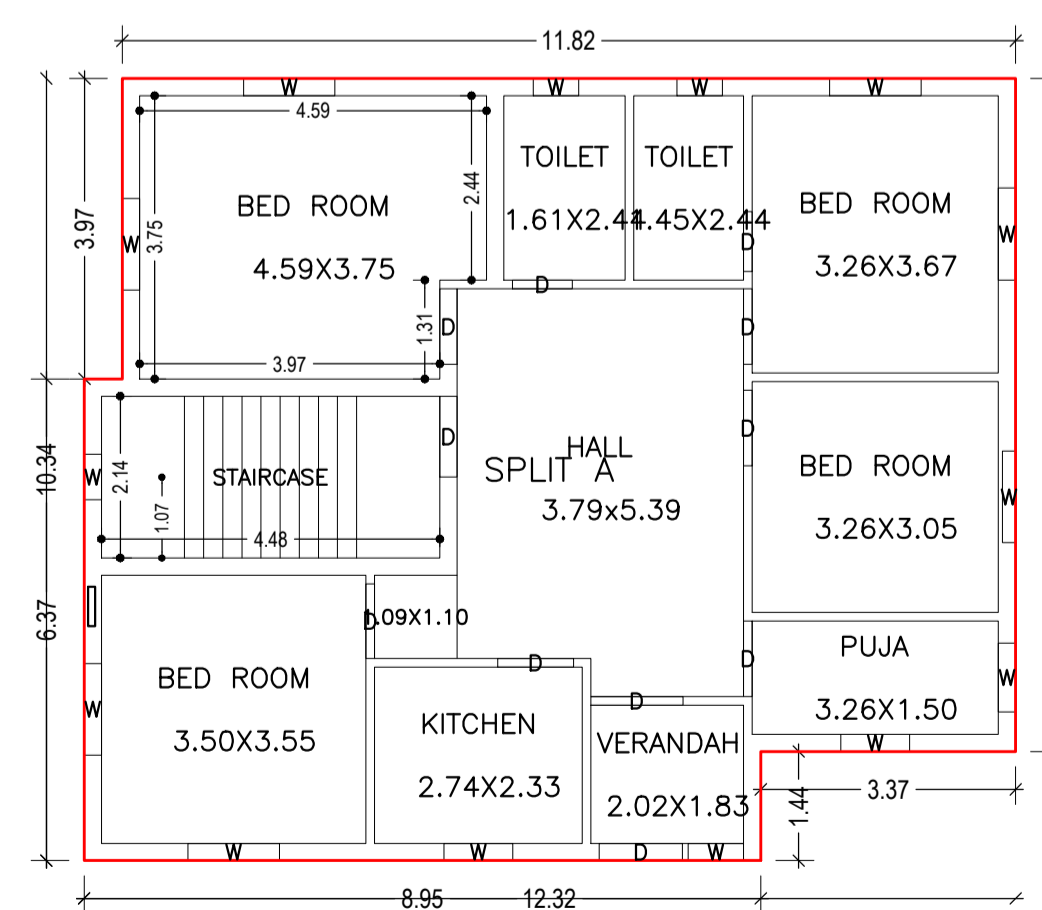

FIRST FLOOR PLAN
(Proposed)
(SCALE 1:100)

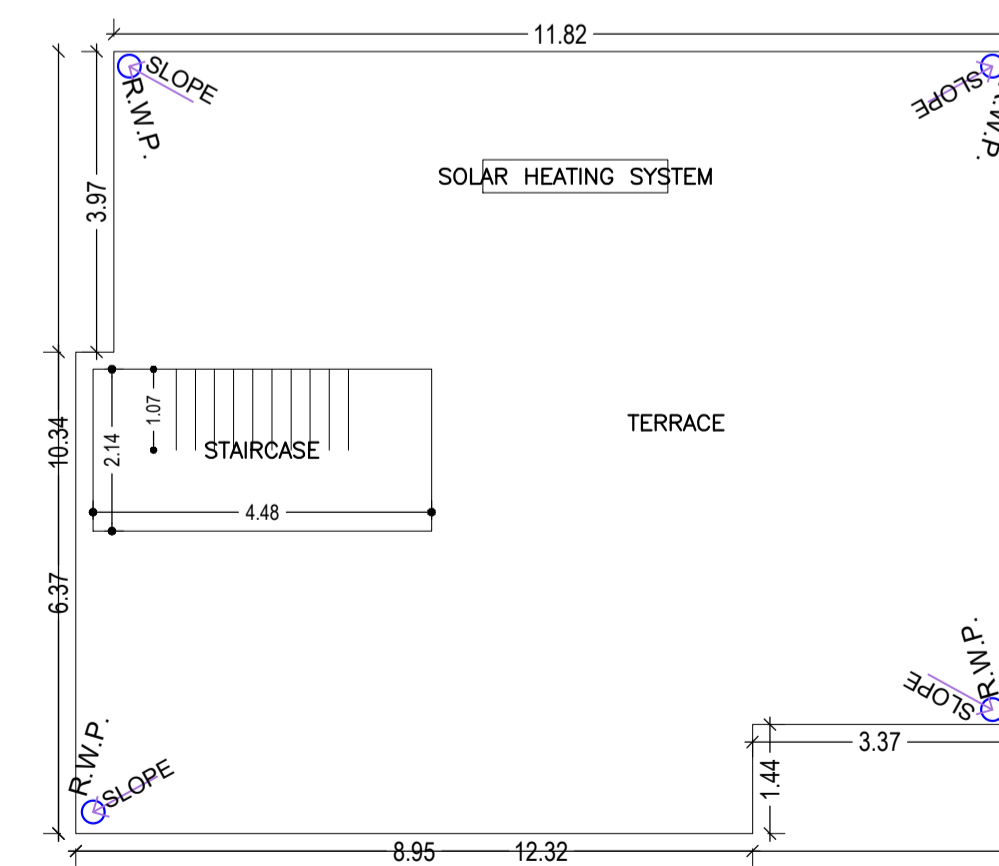

TERRACE FLOOR PLAN
(SCALE 1:100)

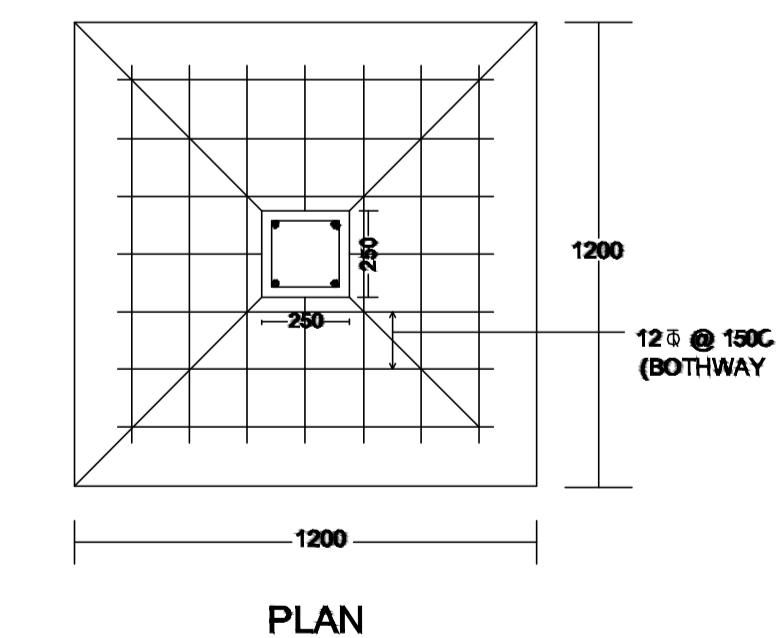

DETAIL OF COLUMNS

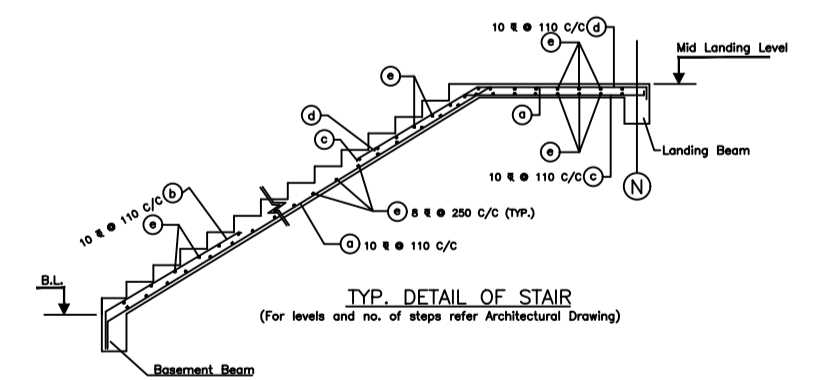

TYP. DETAIL OF STAIR

LTP NAME AND SIGNATURE	STRUCTURAL ENG'S NAME AND SIGNATURE	BUILDER NAME AND SIGNATURE	DIGITAL SIGNATURE
RAJEEV RANJAN SINGH MADA/ENG/0004/2019			