

SITE PLAN
SCALE - 1" = 16'-0"

SITE PLAN

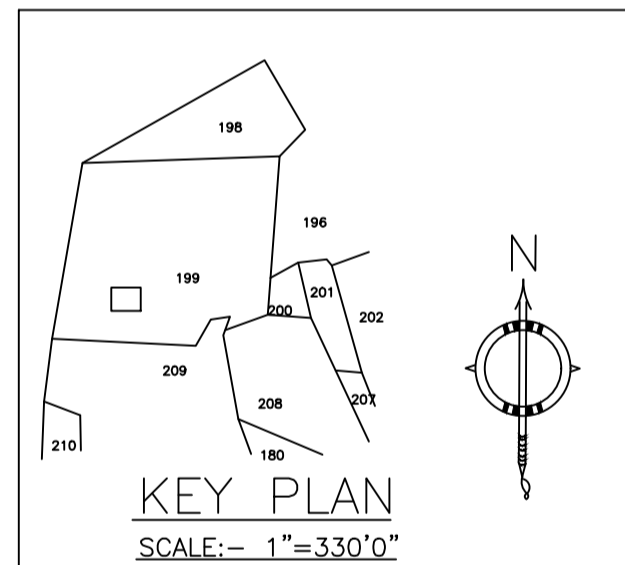

Building :A (RAMRUP)

Floor Name	Total Built Up Area (Sq.mt.)	Deductions (Area in Sq.mt.)	Proposed FAR Area (Sq.mt.)	Total FAR Area (Sq.mt.)	Total Consumed Additional FAR Area (Sq.mt.)	Tnmt (No.)
Ground Floor	81.94	16.62	65.32	65.32	65.32	01
First Floor	81.94	0.00	81.94	81.94	81.94	00
Terrace Floor	0.00	0.00	0.00	0.00	0.00	00
Total	163.88	16.62	147.26	147.26	147.26	01
Total Number of Same Buildings	1					
Total	163.88	16.62	147.26	147.26	147.26	01

SCHEDULE OF DOOR:

BUILDING NAME	NAME	LENGTH	HEIGHT	NOS
A (RAMRUP)	D	0.76	2.10	02
A (RAMRUP)	D	0.79	2.10	01
A (RAMRUP)	D	0.91	2.10	01
A (RAMRUP)	D	0.93	2.10	01
A (RAMRUP)	D	0.97	2.10	01
A (RAMRUP)	D	1.00	2.10	01
A (RAMRUP)	D	1.07	2.10	04
A (RAMRUP)	D	1.52	2.10	01

SCHEDULE OF WINDOW/VENTILATION:

BUILDING NAME	NAME	LENGTH	HEIGHT	NOS
A (RAMRUP)	W	0.84	1.20	03
A (RAMRUP)	W	1.22	1.20	01
A (RAMRUP)	W	1.52	1.20	10
A (RAMRUP)	W	2.55	1.20	02

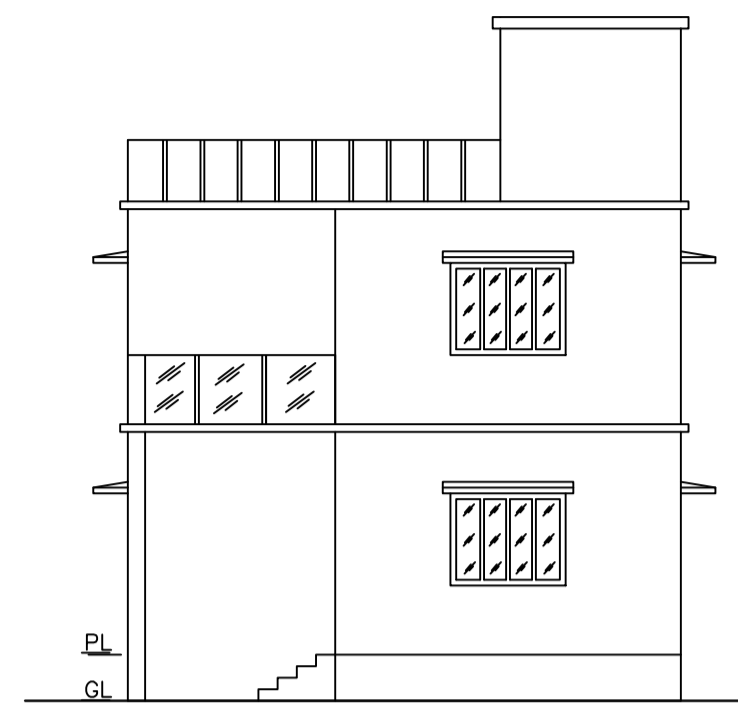

FRONT ELEVATION
SCALE - 1" = 8'-0"

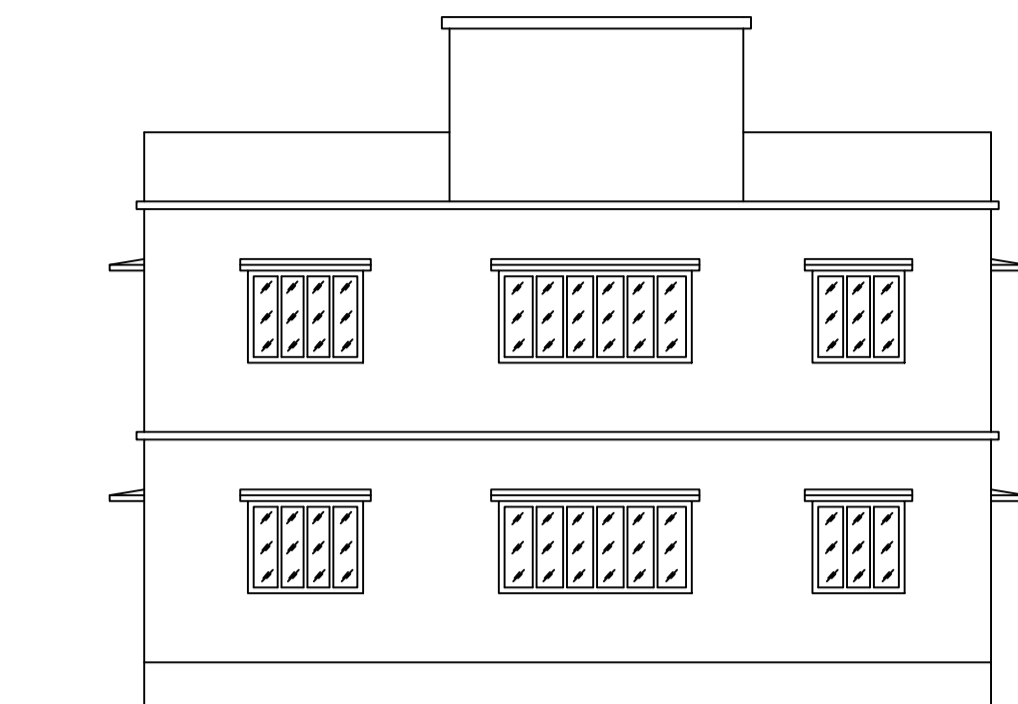

RIGHT SIDE ELEVATION
SCALE - 1" = 8'-0"

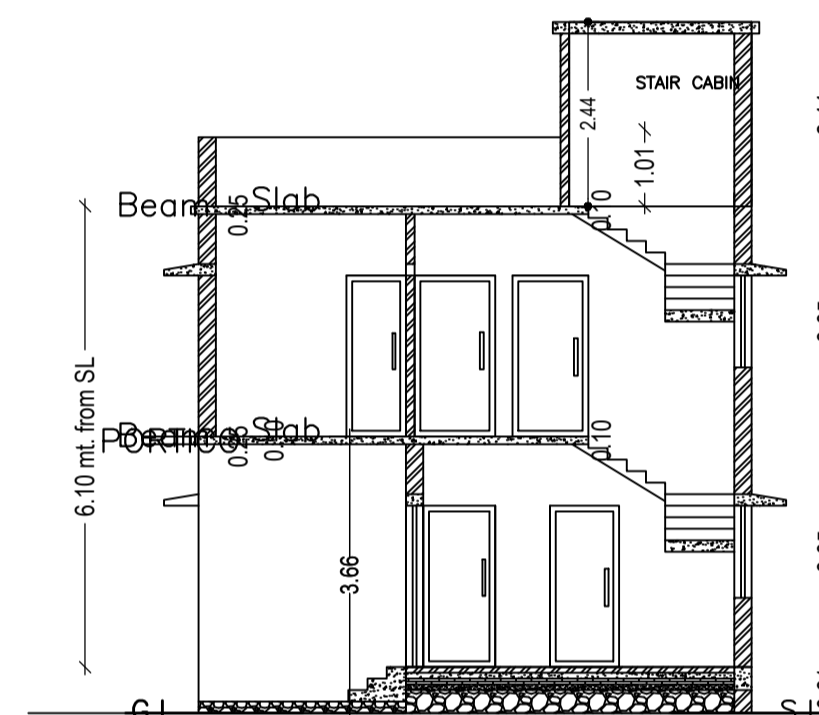

SECTION - XX'
SCALE - 1" = 8'-0"

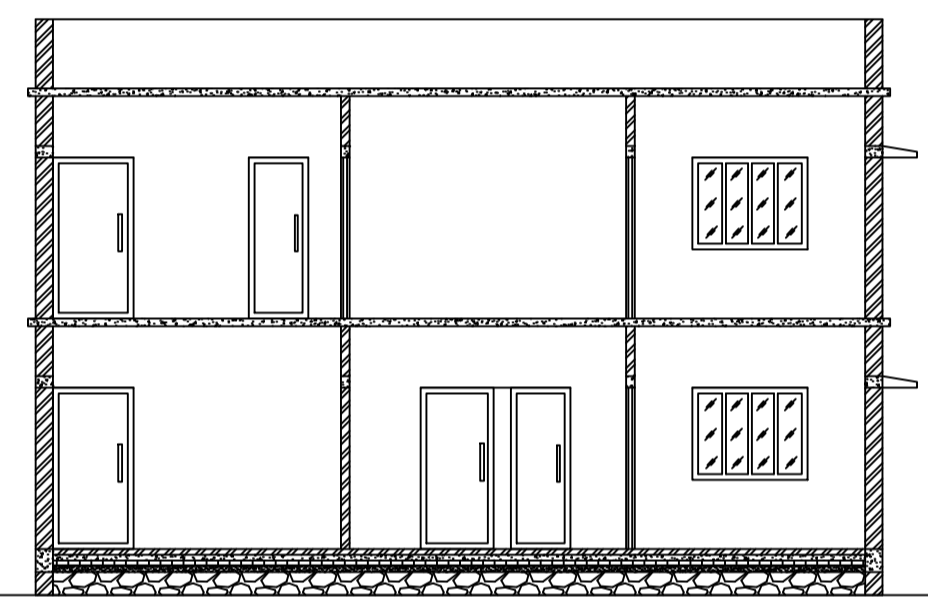

SECTION - YY'
SCALE - 1" = 8'-0"

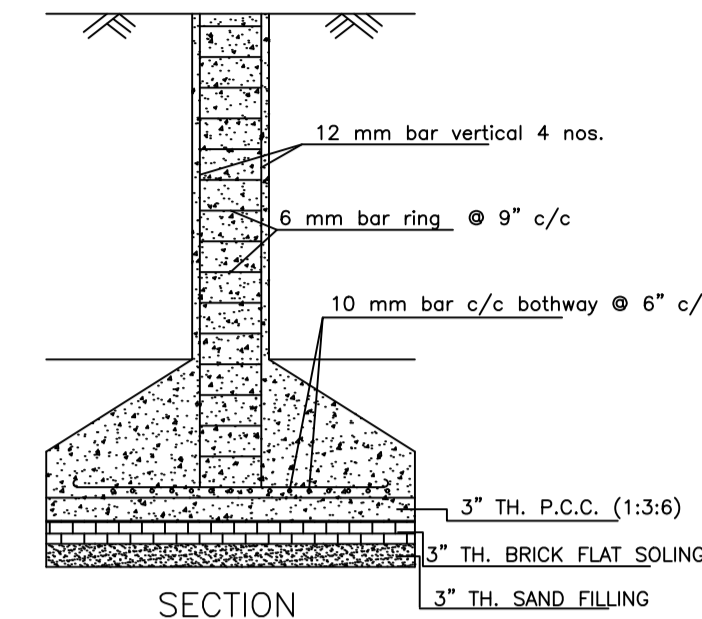

SECTION

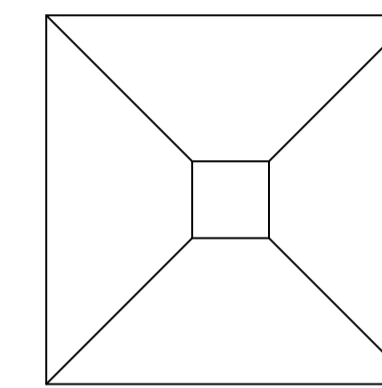

PLAN
DETAILS OF COLUMN FOUNDATION
SCALE - 1" = 2'-0"

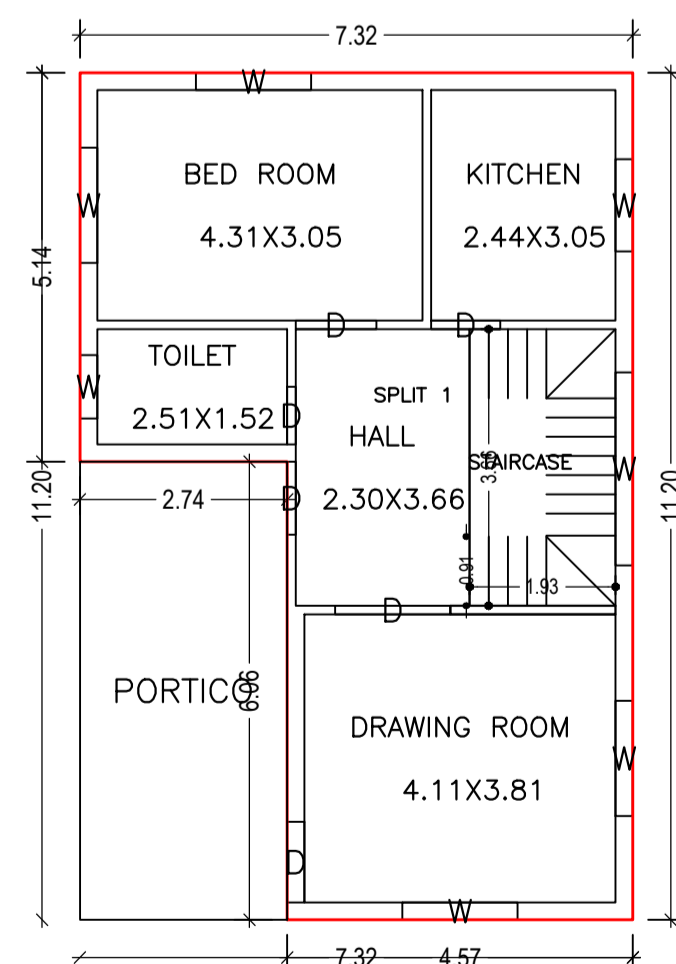

GROUND FLOOR PLAN (Proposed)
SCALE 1:100

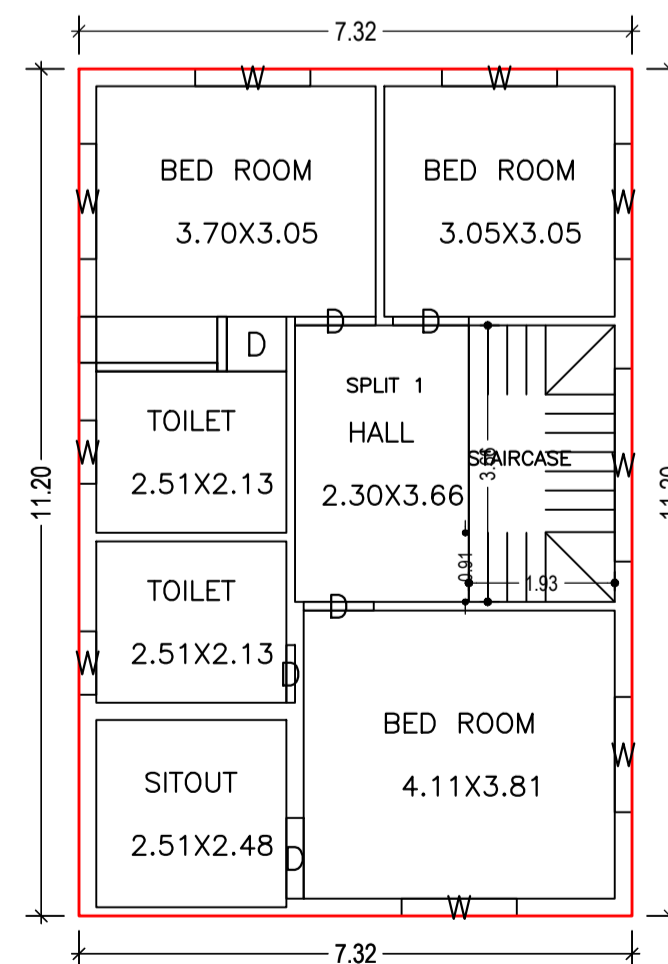

FIRST FLOOR PLAN (Proposed)
SCALE 1:100

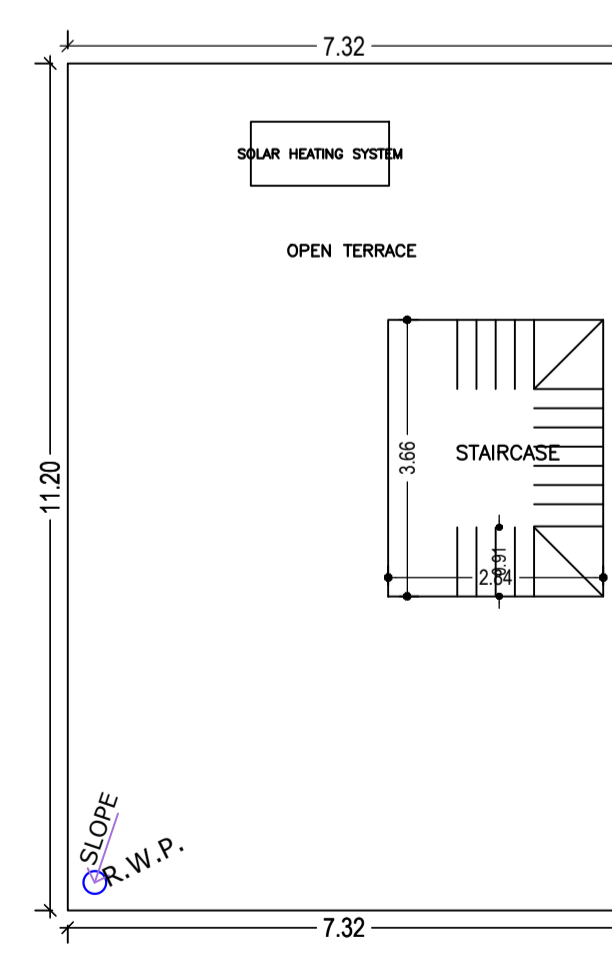

TERRACE FLOOR PLAN (SCALE 1:100)

AREA STATEMENT MINERAL AREA DEVELOPMENT AUTHORITY	VERSION NO.: 1.0.55	VERSION DATE: 16/10/2020
PROJECT DETAIL:	Region: JHARKHAND URBAN LOCAL BODIES	Plot Use: Residential
	District: DHANBAD	Plot SubUse: Bungalow/ Dwelling / Non Apartment
	Authority: MINERAL AREA DEVELOPMENT AUTHORITY	PlotNearbyReligiousStructure: NA
	Inward No: MADA/BP/0047/2021	Plot/SubPlot No: OLD PLOT NO. 72, NEW PLOT NO. 199
	Application Type: General Proposal	North: Plot No. - SAME PLOT
	Project Type: Building Permission	South: Plot No. - SAME PLOT
	Nature of Development: New	East: Plot No. - SAME PLOT
	Location of Development Area: Old Area	West: Road Width - 6.10
AREA DETAILS:		SQ.MT.
AREA OF PLOT (Minimum)	(A)	138.88
NET AREA OF PLOT(Gross Plot Area - Deduction from Gross Plot area)	(A-Deductions)	138.88
Deduction for Balance Plot Area(from Gross Plot Area)		
Common Plot		11.76
Total		11.76
BALANCE AREA OF PLOT(Net Plot Area - Recreational/Amenity space)	(A-Deductions)	127.12
PLOT AREA FOR COVERAGE(Net Plot Area)	(A-Deductions)	138.88
Plot Area for FAR (Net Plot Area + RoadWidening Area)	(A-Deductions)	138.88
COVERAGE CHECK		
Permissible Coverage area (70.00 %)		97.22
Proposed Coverage Area (47.03 %)		65.32
Total Prop. Coverage Area (47.03 %)		65.32
Balance coverage area (22.97 %)		31.90
FAR CHECK		
Perm. FAR Area (2.50)		347.20
Total Perm. FAR area		347.20
Residential FAR		147.26
Proposed FAR Area		147.26
Total Proposed FAR Area		147.26
Consumed FAR (Factor)		1.06
Balance FAR Area		199.94
BUILT UP AREA CHECK		
Total Proposed BuiltUp Area		163.88
ARCHITECT (Regd)		RAM PRATAP SINGH
ENGINEER (Regd)		
SUPERVISOR (Regd)		
OWNER (Regd)		SRI. RAMRUP GOPE
DEVELOPMENT AUTHORITY		LOCAL BODY

PERMISSIBLE COVERAGE AREA (%)	PROPOSED COVERAGE AREA (%)	TOTAL PROP. COVERAGE AREA (%)	BALANCE COVERAGE AREA (%)
70.00	47.03	47.03	22.97

PERMISSIBLE FAR AREA	TOTAL PERMISSIBLE FAR AREA	RESIDENTIAL FAR	PROPOSED FAR AREA	TOTAL PROPOSED FAR AREA	CONSUMED FAR (FACTOR)	BALANCE FAR AREA
2.50	347.20	147.26	147.26	147.26	1.06	199.94

FLOOR NAME	PROPOSED BUILT UP AREA (Sq.mt.)	PROPOSED FAR AREA (Sq.mt.)	TOTAL PROPOSED BUILT UP AREA (Sq.mt.)	TOTAL FAR AREA (Sq.mt.)
Ground Floor	81.94	65.32	81.94	65.32
First Floor	81.94	81.94	81.94	81.94
Terrace Floor	0.00	0.00	0.00	0.00
Total	163.88	147.26	163.88	147.26

BUILDING NAME	BUILDING USE	BUILDING SUBUSE	BUILDING STRUCTURE
A (RAMRUP)	Residential	Bungalow/ Dwelling / Non Apartment	Non-Highrise

FLOOR	NAME	UNITBUA TYPE	UNITBUA AREA	CARPET AREA	NO. OF ROOMS	NO. OF TENEMENT
GROUND FLOOR PLAN	SPLIT 1	FLAT	147.26	146.60	5	1
FIRST FLOOR PLAN	SPLIT 1	FLAT	0.00	0.00	7	0
Total			147.26	146.60	12	1

BUILDING	NO. OF SAME BLDG	TOTAL BUILT UP AREA (Sq.mt.)	DEDUCTIONS (Area in Sq.mt.)	PROPOSED FAR AREA (Sq.mt.)	TOTAL FAR AREA (Sq.mt.)	TOTAL CONSUMED ADDITIONAL FAR AREA (Sq.mt.)	TNMT (NO.)
A (RAMRUP)	1	163.88	16.62	147.26	147.26	147.26	01
Grand Total	1	163.88	16.62	147.26	147.26	147.26	01

LTP NAME AND SIGNATURE	STRUCTURAL ENG'S NAME AND SIGNATURE	BUILDER NAME AND SIGNATURE	DIGITAL SIGNATURE
RAM PRATAP SINGH MADA/ARC/0024/2019			

Proposal Basic Information

Proposal File No.	MADA/BP/0047/2021
Owner Name	SRI. RAMRUP GOPE
Khata No	OLD KHATA NO-16, NEW KHATA NO-14
Plot No	OLD PLOT NO. 72, NEW PLOT NO. 199
Village Name	Tilakraydih
Use	Residential
SubUse	Bungalow/ Dwelling / Non Apartment

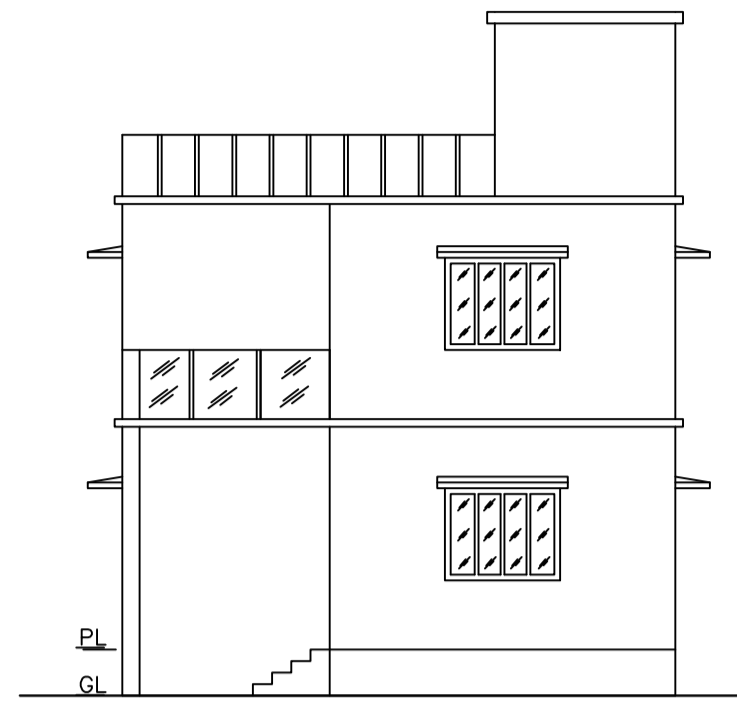

FRONT ELEVATION
SCALE - 1" = 8'-0"

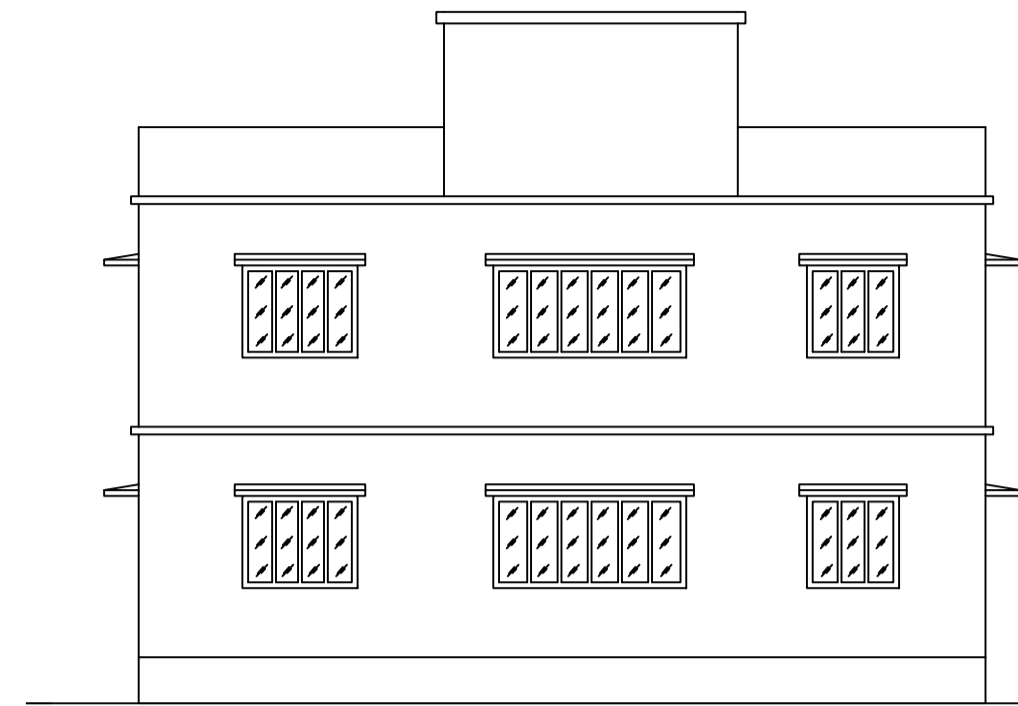

RIGHT SIDE ELEVATION
SCALE - 1" = 8'-0"

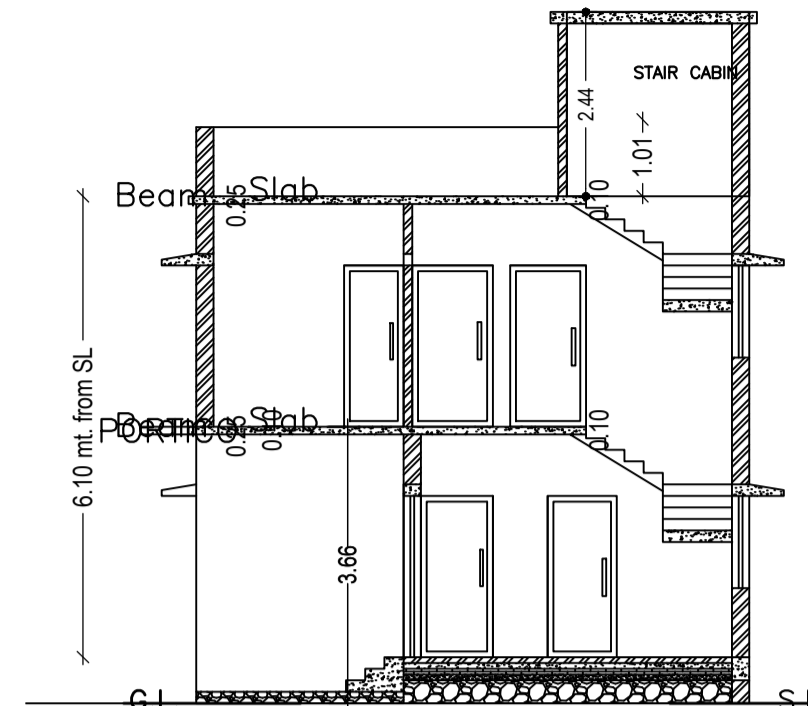

SECTION - XX'
SCALE - 1" = 8'-0"

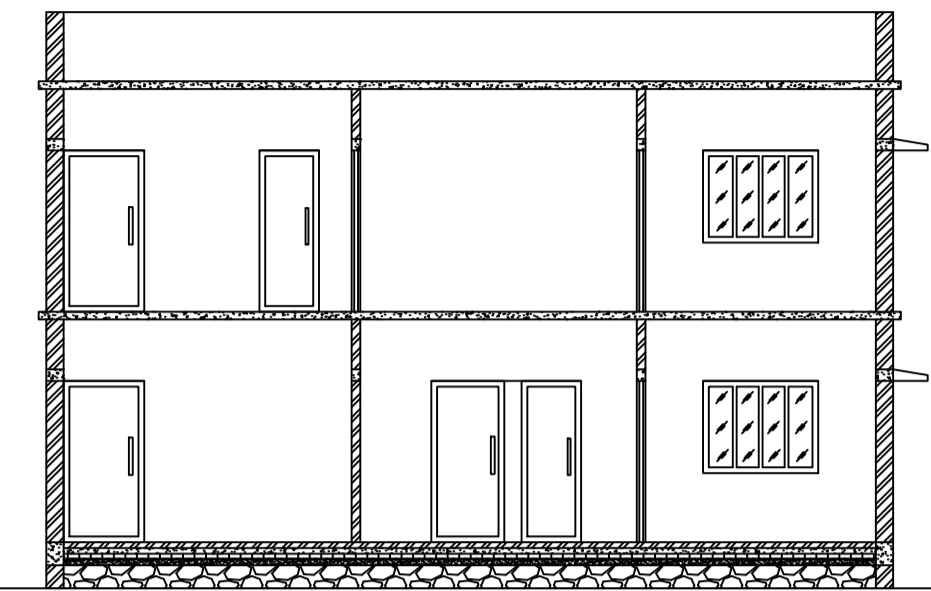

SECTION - YY'
SCALE - 1" = 8'-0"

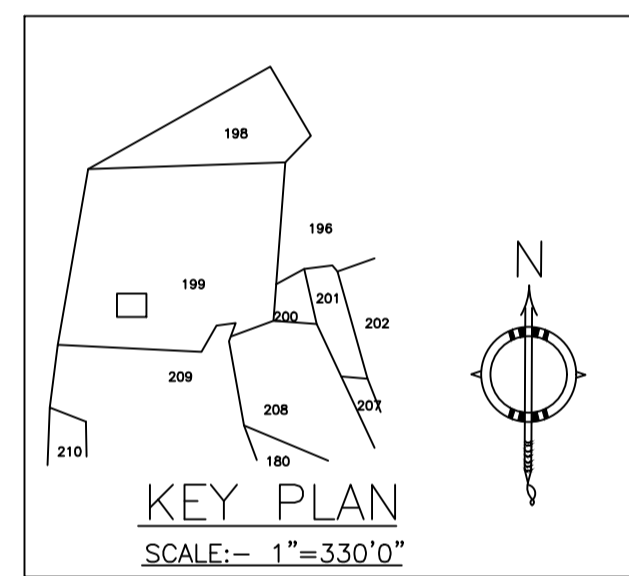

KEY PLAN
SCALE:- 1"=330'0"

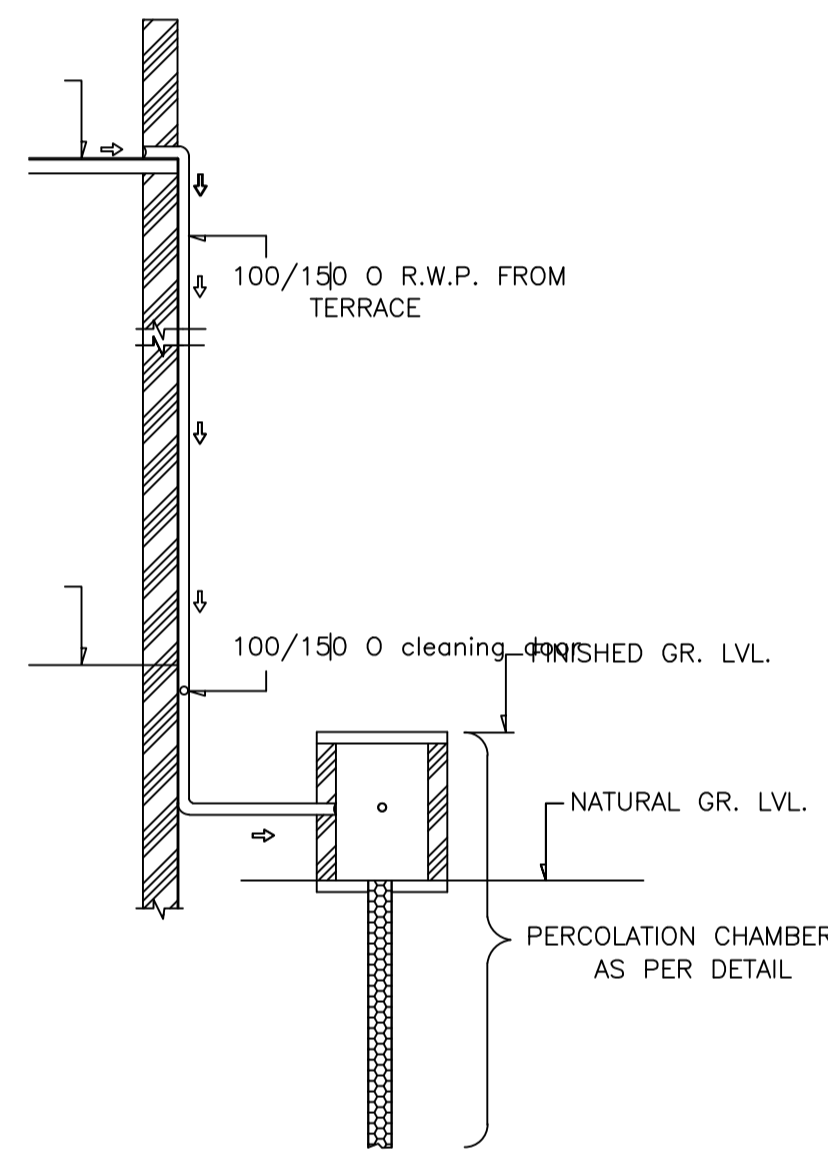

ROOF TOP RAIN WATER COLLECTION SYSTEM
SCALE = 1" = 4'-0"

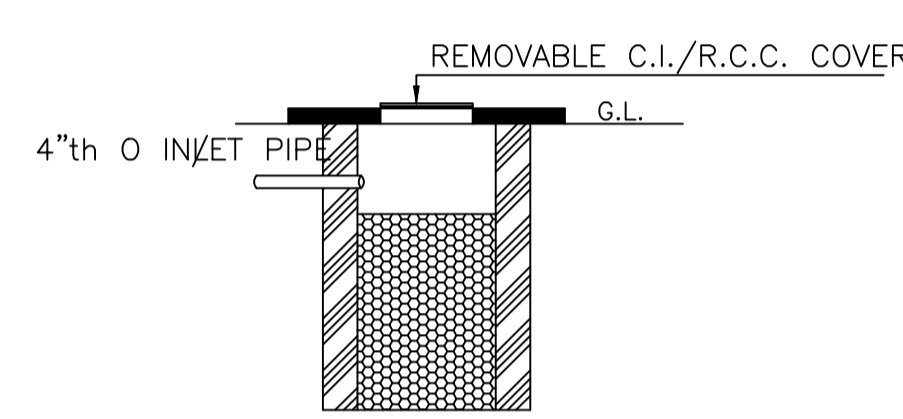

SECTION OF SOAK PIT

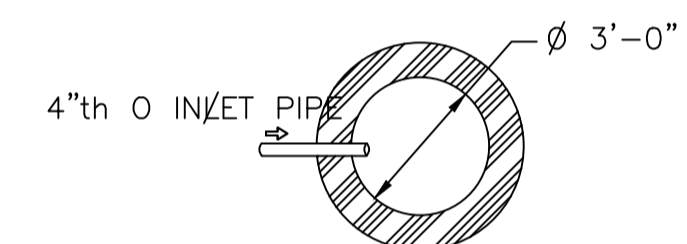

DETAILS OF SOAK PIT
SCALE = 1" = 2'-0"

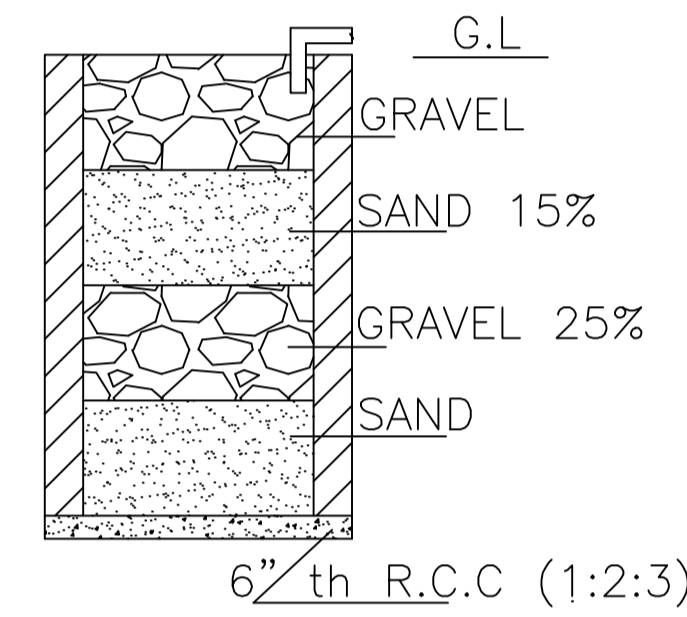

SECTION ON A - B

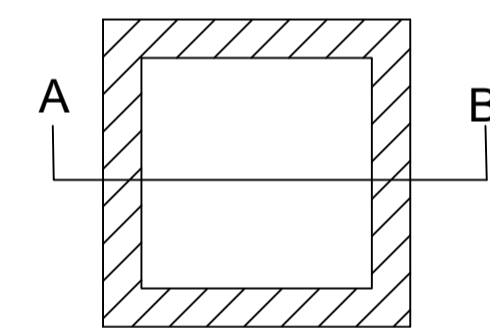

DETAILS DRAWING OF RAIN WATER HARVESTING
SCALE:- 1"=2'-0"

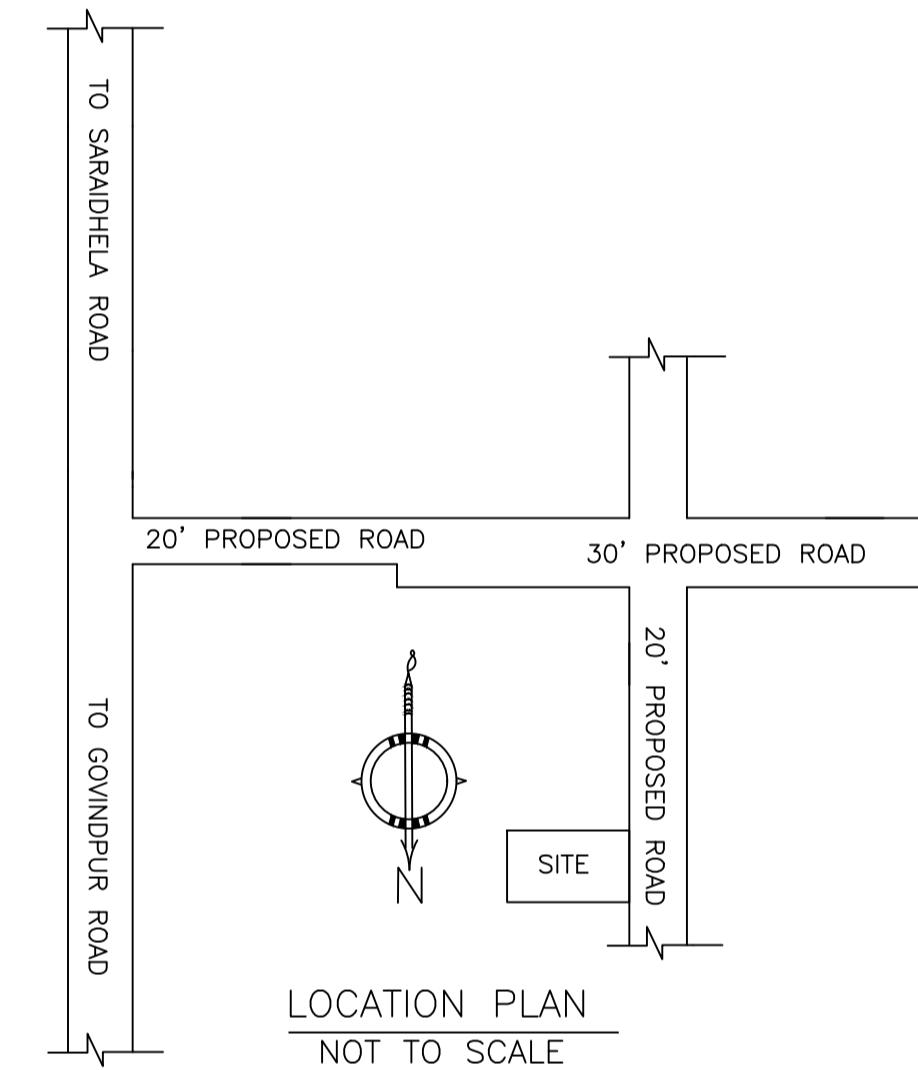

LOCATION PLAN
NOT TO SCALE

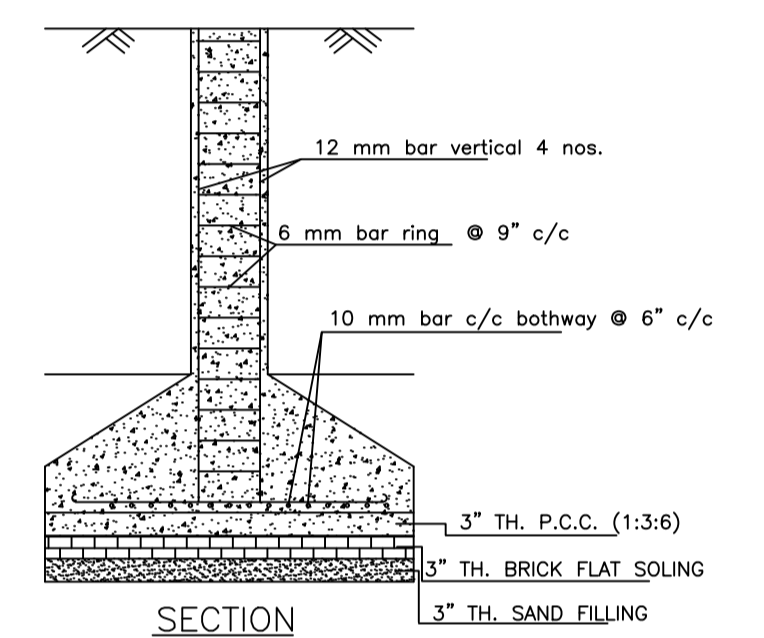

SECTION

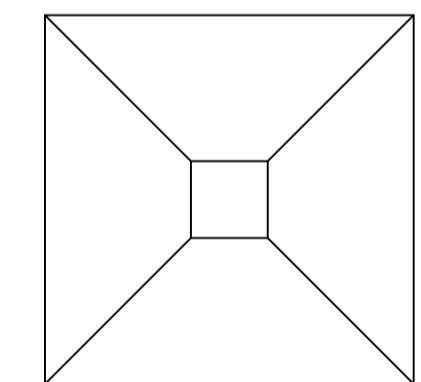

PLAN

DETAILS OF COLUMN FOUNDATION
SCALE - 1" = 2'-0"

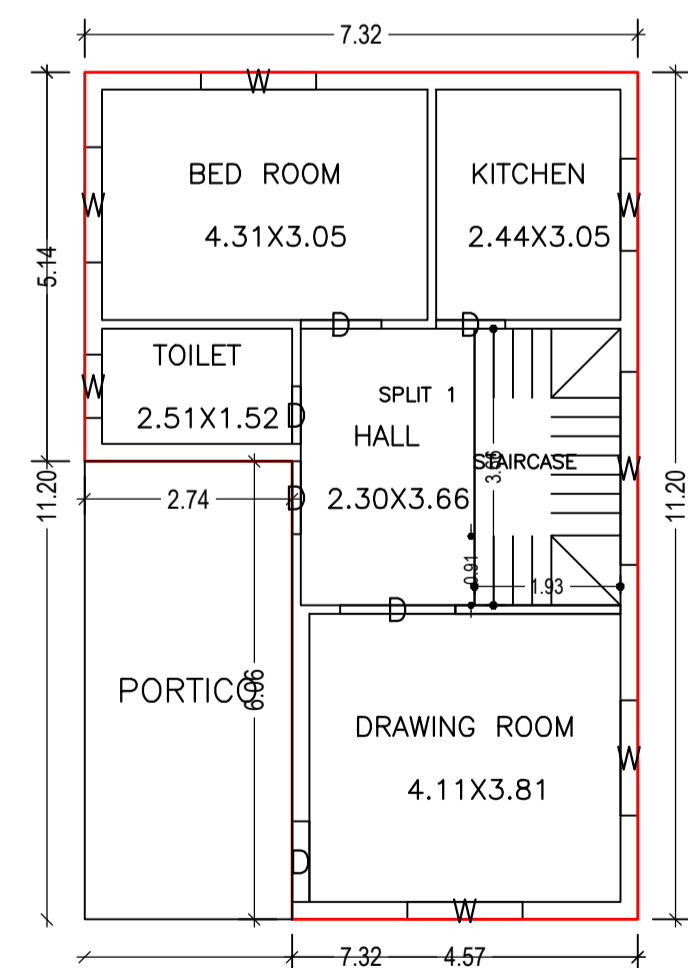

GROUND FLOOR PLAN
(Proposed)
SCALE 1:100

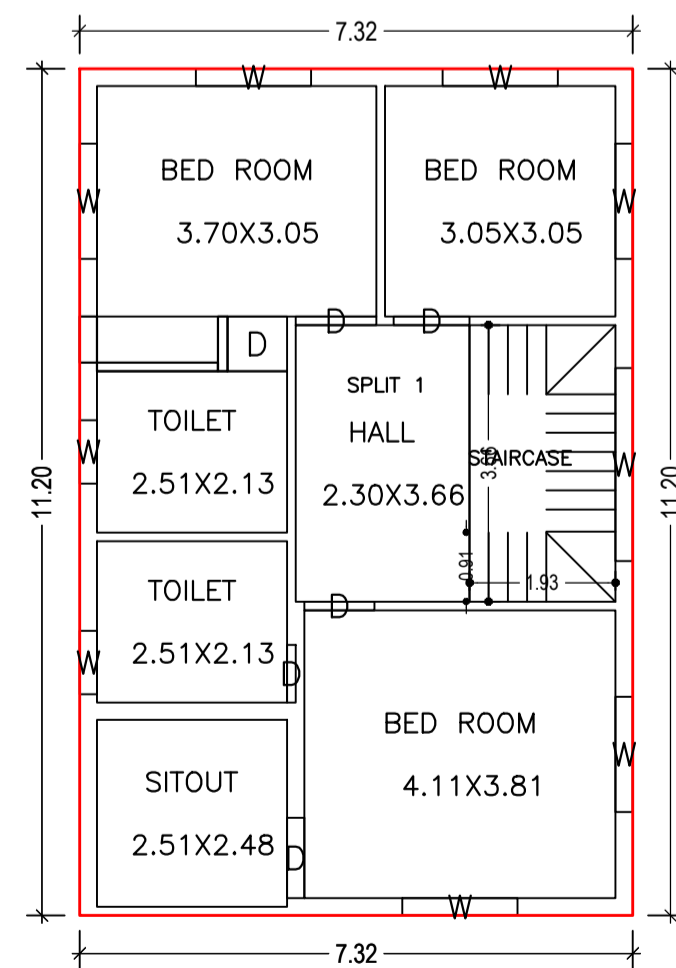

FIRST FLOOR PLAN
(Proposed)
SCALE 1:100

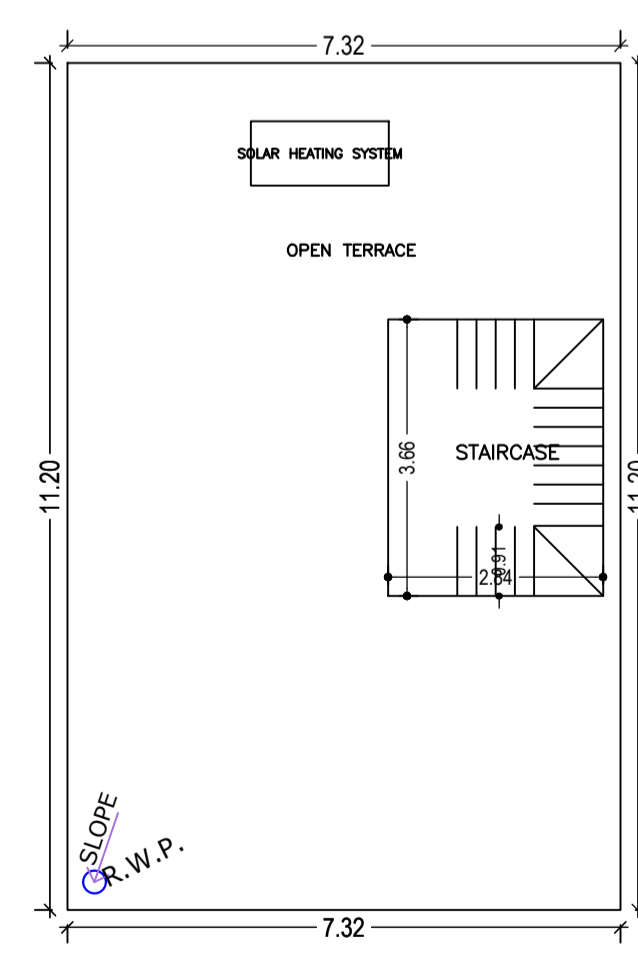

TERRACE FLOOR PLAN
(SCALE 1:100)

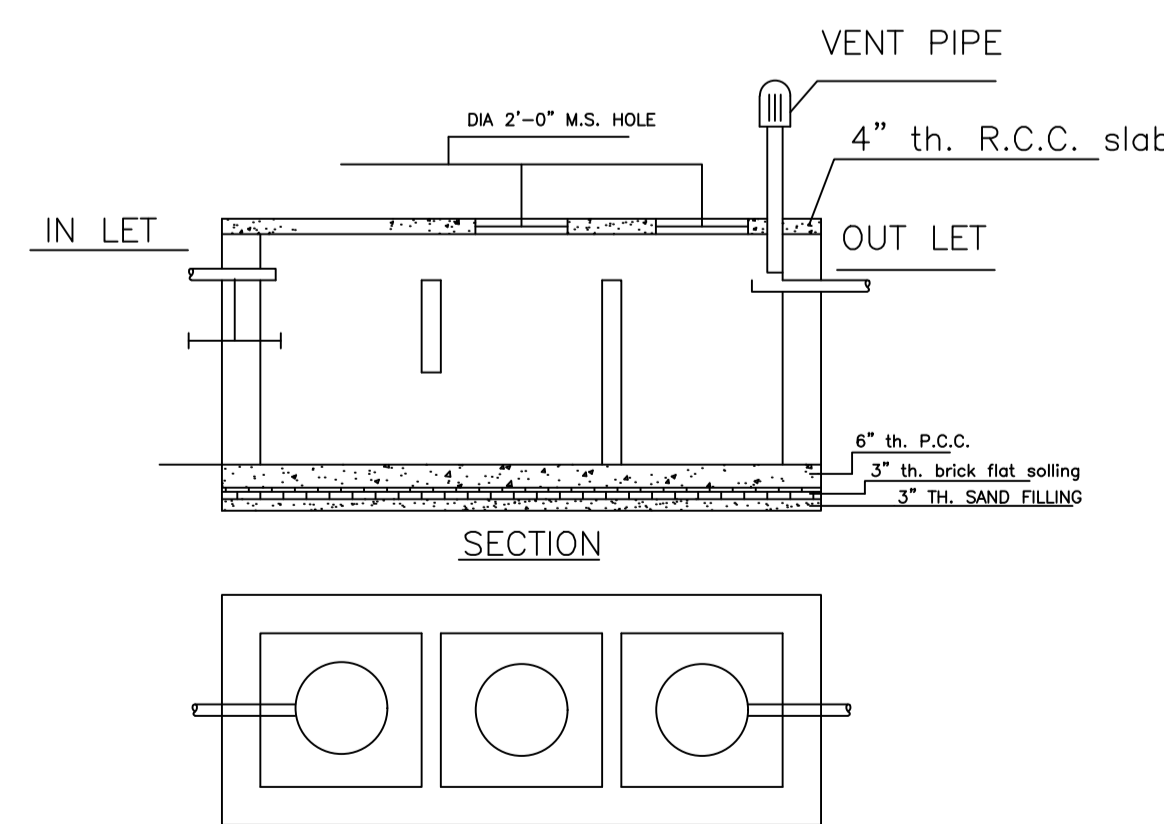

SECTION

DETAILS OF SEPTIC TANK
SCALE - 1" = 4'-0"

LTP NAME AND SIGNATURE	STRUCTURAL ENG'S NAME AND SIGNATURE	BUILDER NAME AND SIGNATURE	DIGITAL SIGNATURE
RAM PRATAP SINGH MADA/ARC/0024/2019			