

Project Title : GEETA SINGH AND NIDHI SINGH

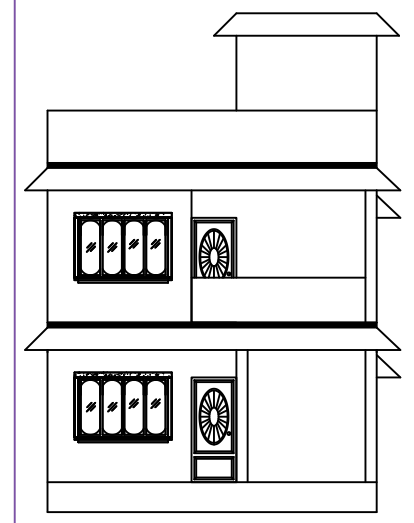

FRONT ELEVATION

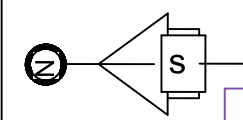
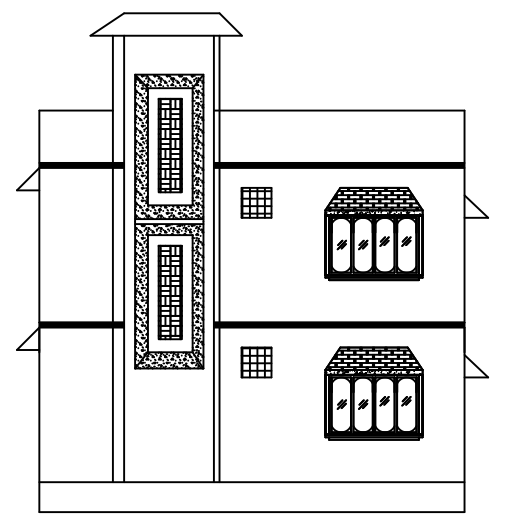

RIGHT SIDE ELEVATION

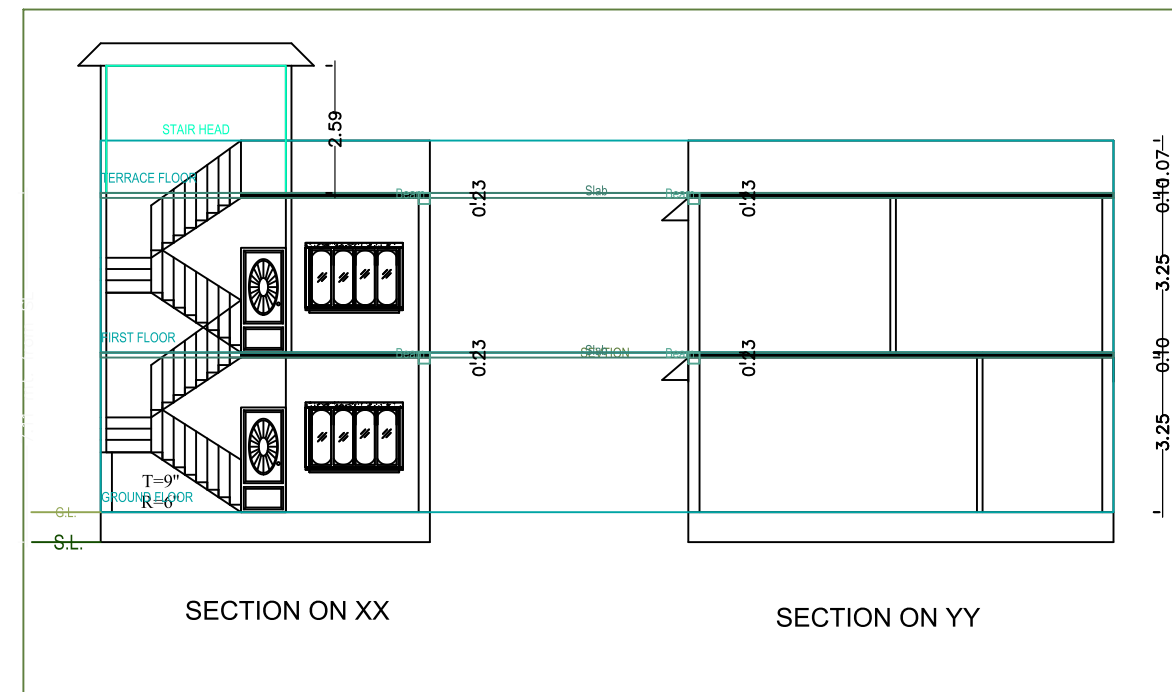

SECTION ON XX

SECTION ON YY

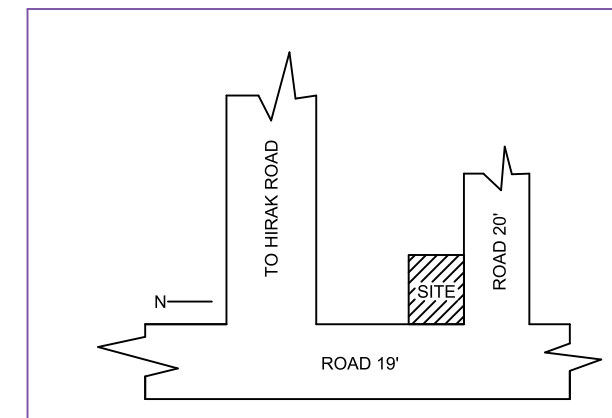

LOCATION PLAN

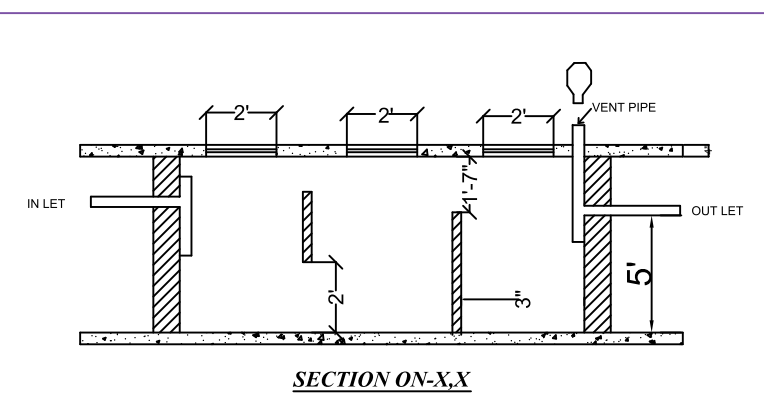

SECTION ON XX

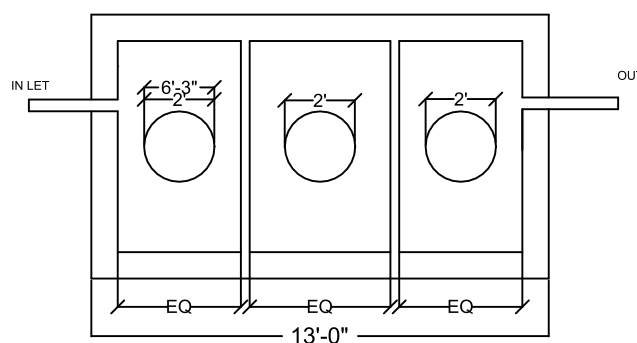

SEPTIC TANK

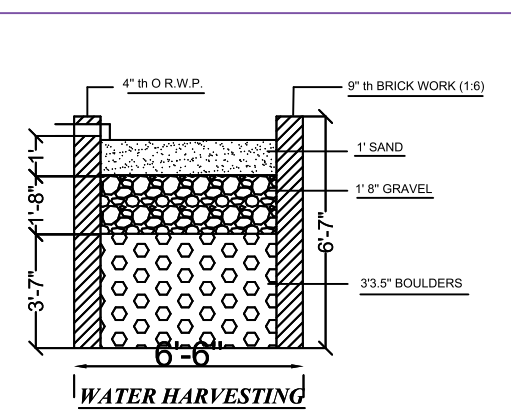

WATER HARVESTING

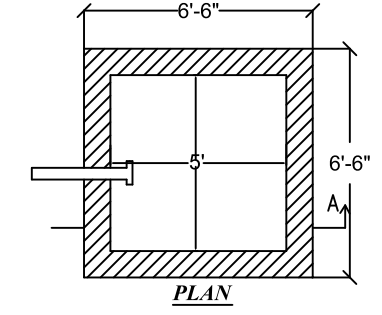

PLAN

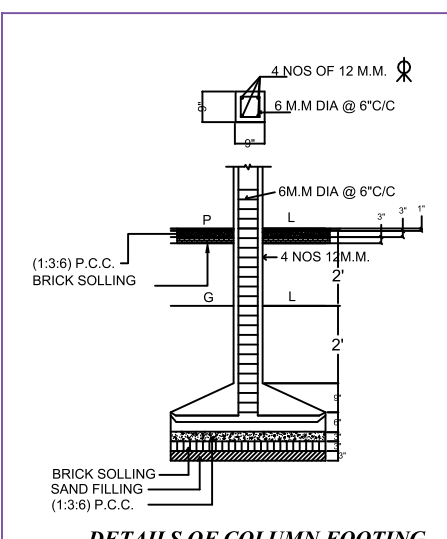

DETAILS OF COLUMN FOOTING

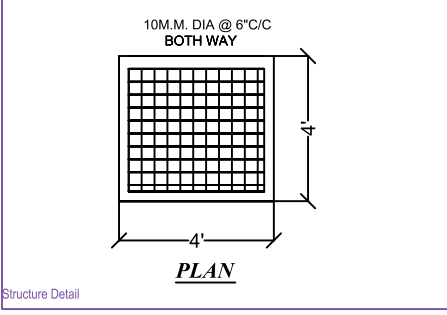

PLAN

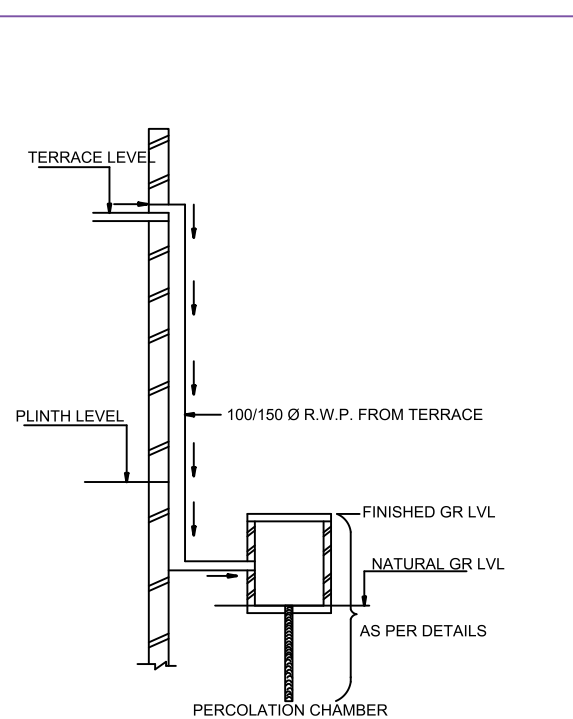

ROOF TOP RAIN WATER COLLECTION SYSTEM

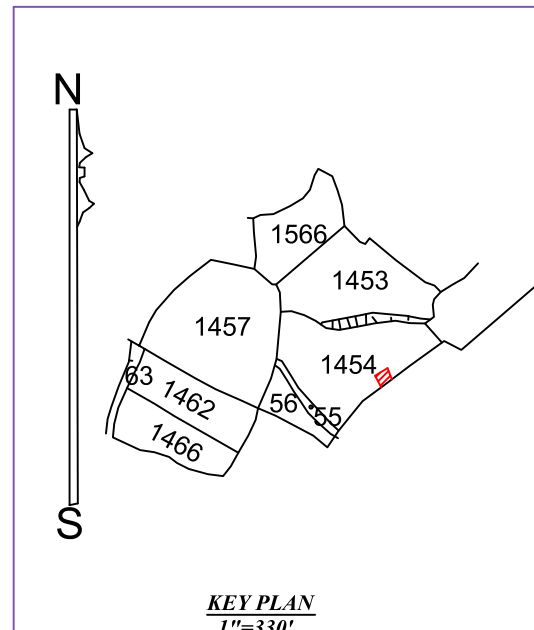

KEY PLAN

**BRIEF SPECIFICATION**  
**FOUNDATION** :- R.C.C. (1:1.5:3) Column footing foundation.  
**PLINTH** :- 12"th R.C.C. (1:1.5:3) all round on plinth level  
**FLOORING** :- 1.5"th I.P.S flooring over 3"th P.C.C. (1:3:6)  
**SUPER STRUCTURE** :- First class brick work in cement mortar (1:6)  
**SLAB,BEAM & LINTEL** :- All R.C.C. work (1:1.5:3).  
**WOOD WORK** :- All door & window frames are of sal wood and shutter. 12m thick  
**PLASTERING** :- 6.m,thick cement plaster (1:6) in both side.

**SCHEDULE**

D1 - 2'6" X 7'0"	W - 6'0" X 4'0"
D - 3'6" X 7'0"	W1 - 4'0" X 4'0"
	V - 2'0" X 2'0"

**DETAILS OF AREA**

AVAI LAND AREA (AS PER DEED)	1000.00 sqft
AVAI LAND AREA	1000.00 sqft
PLINTH AREA	625.16 sqft
FIRST FLOOR AREA	625.16 sqft
TOTAL BUILTUP AREA	1250.32 sqft
% PLINTH AREA	62.51 %
F.A.R.	1.25

**TITLE OF DRAWING**  
 PROPOSED RESIDENTIAL BUILDING PLAN OF (1) SMT. GEETA SINGH W/O SATRU SUDAN SINGH (2) SMT. NIDHI SINGH D/O ARUN KUMAR SINGH, MOUZA IN NAWADIH NO. 02, OLD KHATA NO. 74, NEW KHATA NO. 64, OLD PLOT NO. 1454, NEW PLOT NO.1633, AREA- 2.30 DECIMAL, LOT NO. 01 (DIST-DHANBAD)

**SIG. OF OWNER**

**SIG. OF ENGINEER**  
 (Er. SANTOSH)  
 HI-TECH ASSOCIATES  
 22, UNION-CLUB MARKET  
 LUBY CIRCULAR ROAD  
 DHANBAD

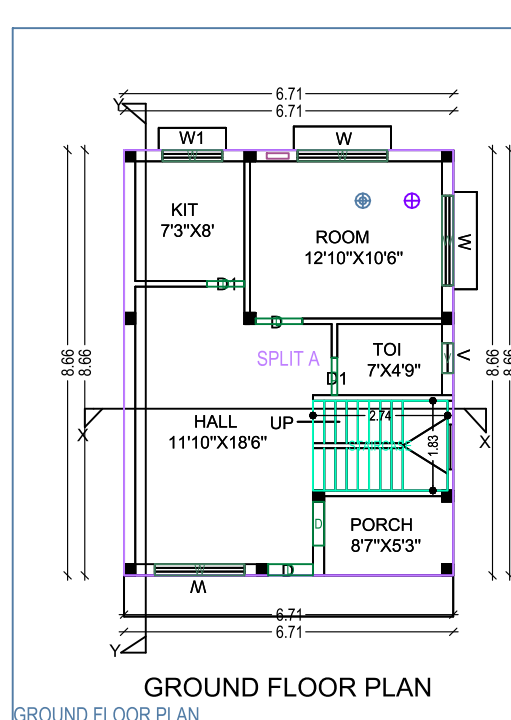
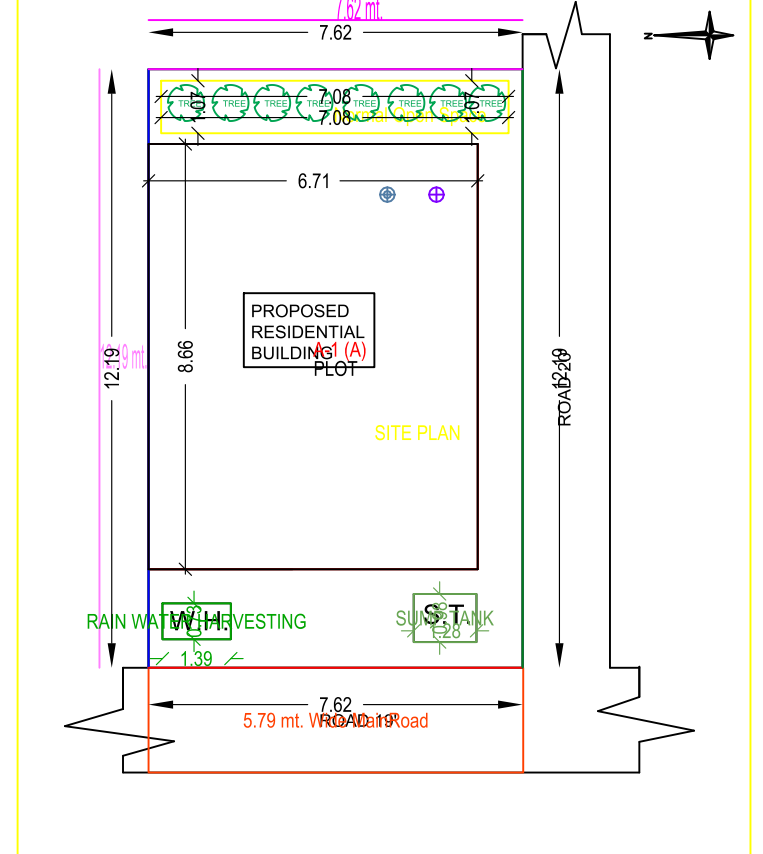

GROUND FLOOR PLAN

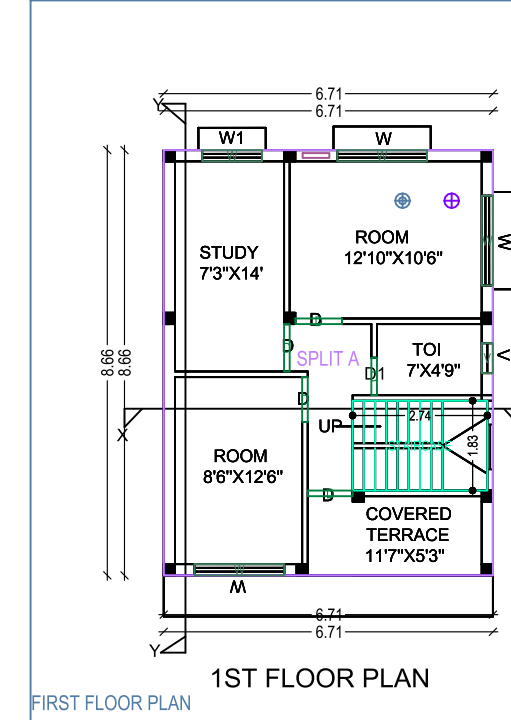

1ST FLOOR PLAN

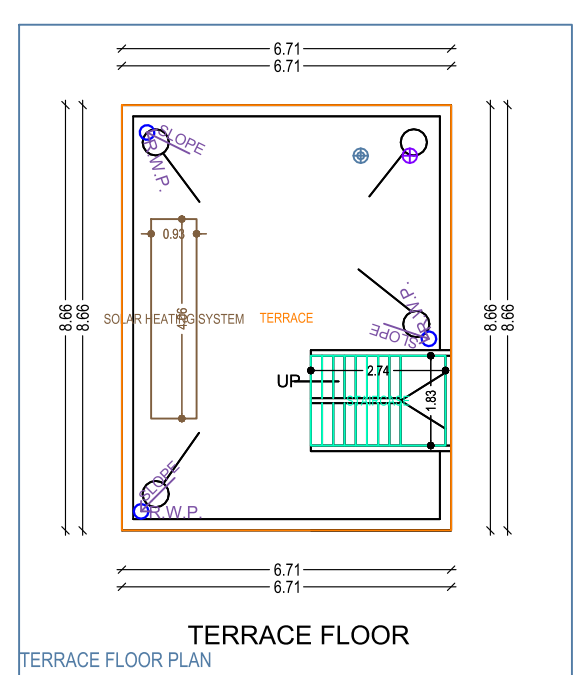

TERRACE FLOOR PLAN

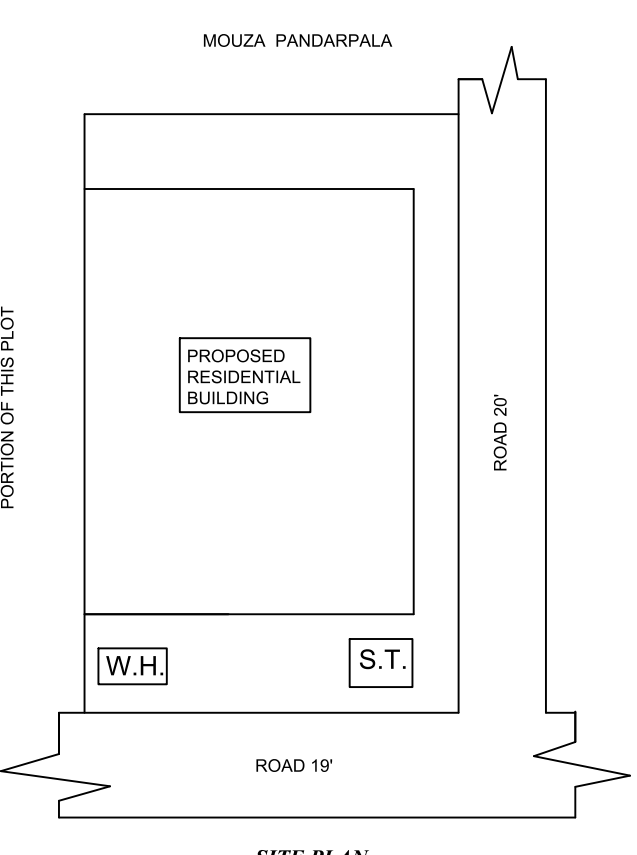

SITE PLAN

ALL DIMENTION ARE IN INTCHEFT. SCALE-1"=8'

Building A (A)

Floor Name	Total Built Up Area (Sq.mt.)	Proposed FAR Area (Sq.mt.)	Total FAR Area (Sq.mt.)	Terrt (No.)
Ground Floor	58.08	58.08	58.08	01
First Floor	58.08	58.08	58.08	00
Terrace Floor	0.00	0.00	0.00	00
Total	116.16	116.16	116.16	01
Total Number of Same Buildings	1			
Total	116.16	116.16	116.16	01

SCHEDULE OF JOINERY:

BUILDING NAME	NAME	LENGTH	HEIGHT	NOS
A(A)	D	0.78	2.10	03
A(A)	D	0.89	2.10	01
A(A)	D	0.91	2.10	03
A(A)	D	0.86	2.10	02
A(A)	D	0.97	2.10	01
Total	-	-	-	10

SCHEDULE OF JOINERY:

BUILDING NAME	NAME	LENGTH	HEIGHT	NOS
A(A)	D	0.81	1.00	02
A(A)	W	1.22	1.20	02
A(A)	W	1.43	1.20	06
Total	-	-	-	10

UnitBUA Table for Building A (A)

FLOOR	Name	UnitBUA Type	UnitBUA Area	Carpet Area	No. of Rooms	No. of Terrace
GROUND FLOOR PLAN	SPLIT A	FLAT	116.16	116.06	1	1
Total	-	-	116.16	116.06	1	1

AREA STATEMENT: MINERAL AREA DEVELOPMENT	VERSION NO. : 1.07
AUTHORITY:	VERSION DATE: 18/10/2020
PROJECT DETAIL:	
Township No.:	Plot Use: Residential
Region: DHANBAD URBAN LOCAL BODIES	Plot Section: Bangladeshi Dwelling/ Non-Apartment
District: DHANBAD	Land Use Zone: 'N'
Application Type: General Proposal	Abutting Road Width: -
Project Type: Building Permission	Plot No.:
Nature of Development: New	Revenue Survey No/Survey No.:-
Location: Old Area	Thana No.:
Sub Location: 'N'	Modeling No.:
Village/Mouza Name: -	Khata No.:
Ward No.:	North: -
Road/Street: -	South: -
	East: -
	West: -

AREA DETAILS

AREA OF PLOT (Minimum)	(A)	(B)	(SQ.MT)
Total Plot Area (Gross Plot Area)	(A-Deductions)		92.90
Deductions for Balance Plot Area (From Gross Plot Area)			7.57
Total			85.33
Balance Plot Area (Net Plot Area (Non-Residential/Amenity spaces))	(A-Deductions)		85.33
Plot Area for Coverage (Net Plot Area)	(A-Deductions)		92.90
Plot Area for FSI (Net Plot Area (Residential/Amenity spaces))	(A-Deductions)		92.90

COVERAGE CHECK

Proposed Coverage Area (82.52 %)	58.08
Total Coverage Area (82.52 %)	58.08

FAR CHECK

Proposed Area of FAR	116.16
Total Area of FAR	116.16

BUILT UP AREA CHECK

Total Proposed Built Up Area	116.16
Actual Length / Supervisor (Sign)	OWNER

DEVELOPMENT AUTHORITY LOCAL BODY

COLOR INDEX

Plot Boundary	Green
Abutting Road	Red
Proposed Work (Coverage Area)	Blue
Existing (To be retained)	Yellow
Existing (To be demolished)	Orange

MARGIN DETAIL:

Building / W/P Name	Road Name	Front Margin	Rear Margin	Side Margin	Side Margin
A(A)	3.75 M. Wide Main Road	2.01	1.52	0.00	0.91

FAR & Terment Details (Table 4c-1)

Building	No. of Same Bldg	Total Built Up Area (Sq.mt.)	Proposed FAR Area (Sq.mt.)	Total FAR Area (Sq.mt.)	Terrt (No.)
A(A)	1	116.16	116.16	116.16	01
Grand Total	1	116.16	116.16	116.16	01