

Proposal Basic Information	
Proposal File No.	MADA/BP/0170/2021
Owner Name	(1) SMT. GEETA SINGH (2) SMT. NIDHI SINGH
Khata No	OLD- 74, NEW- 64
Plot No	OLD- 1454, NEW- 1633
Village Name	Nawadh
Use	Residential
SubUse	Bungalow/ Dwelling / Non Apartment

AREA STATEMENT MINERAL AREA DEVELOPMENT AUTHORITY		VERSION NO.: 1.0.60	VERSION DATE: 16/10/2020
PROJECT DETAIL:			
Region: JHARKHAND URBAN LOCAL BODIES	Plot Use: Residential		
District: DHANBAD	Plot SubUse: Bungalow/ Dwelling / Non Apartment		
Authority: MINERAL AREA DEVELOPMENT AUTHORITY	PlotNearbyReligiousStructure: NA		
Inward No: MADA/BP/0170/2021	Plot/SubPlot No: OLD- 1454, NEW- 1633		
Application Type: General Proposal	North: Plot No. - PORTION OF THIS PLOT		
Project Type: Building Permission	South: Road Width - 6.09		
Nature of Development: New	East: Plot No. - MOUZA PANDARPALA		
Location of Development Area: Old Area	West: Road Width - 5.79		
AREA DETAILS:			
AREA OF PLOT (Minimum)	(A)		SQ.MT. 92.75
NET AREA OF PLOT(Gross Plot Area - Deduction from Gross Plot area)	(A-Deductions)		92.75
Deduction for Balance Plot Area(from Gross Plot Area)			
Common Plot			7.57
Total			7.57
BALANCE AREA OF PLOT(Net Plot Area - Recreational/Amenity space)	(A-Deductions)		85.18
PLOT AREA FOR COVERAGE(Net Plot Area)	(A-Deductions)		92.75
Plot Area for FAR (Net Plot Area + RoadWidening Area)	(A-Deductions)		92.75
COVERAGE CHECK			
Permissible Coverage area (70.00 %)			64.92
Proposed Coverage Area (62.62 %)			58.08
Total Prop. Coverage Area (62.62 %)			58.08
Balance coverage area (7.37 %)			6.84
FAR CHECK			
Perm. FAR Area (1.80)			166.95
Total Perm. FAR area			166.95
Residential FAR			116.16
Proposed FAR Area			116.16
Total Proposed FAR Area			116.16
Consumed FAR (Factor)			1.25
Balance FAR Area			50.79
BUILT UP AREA CHECK			
Total Proposed BuiltUp Area			116.16
ARCHITECT (Regd)	SANTOSH		
ENGINEER (Regd)			
SUPERVISOR (Regd)			
OWNER (Regd)	(1) SMT. GEETA SINGH (2) SMT. NIDHI SINGH		
DEVELOPMENT AUTHORITY		LOCAL BODY	

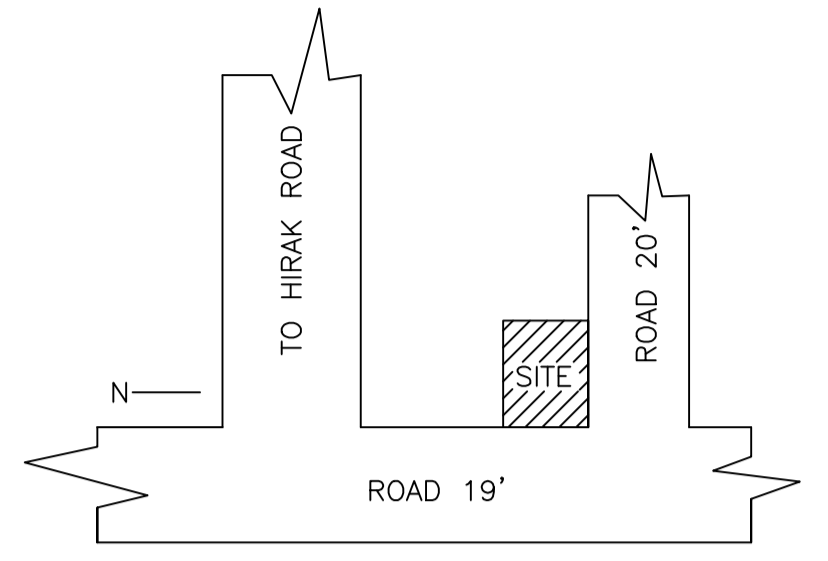

LOCATION PLAN

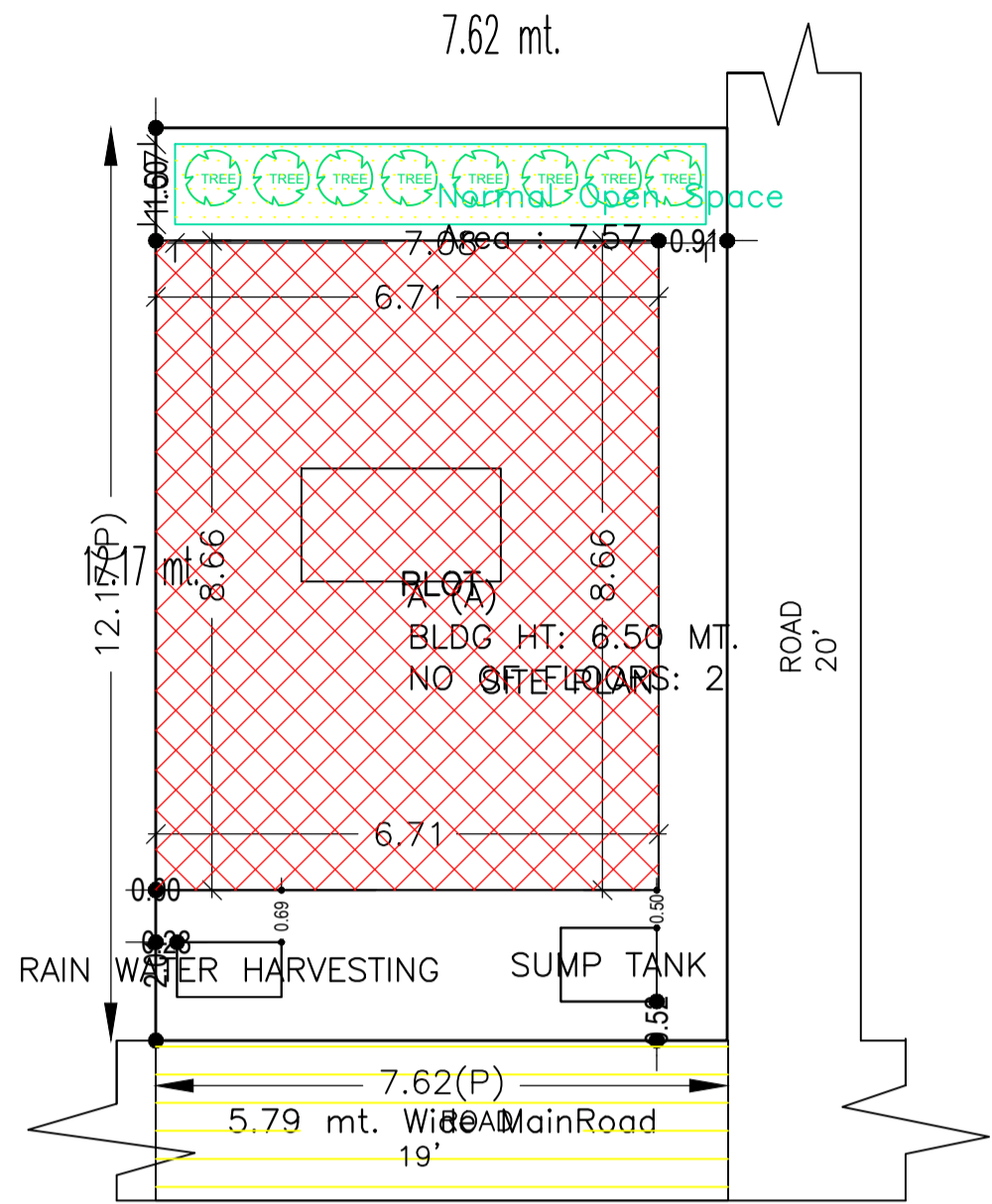
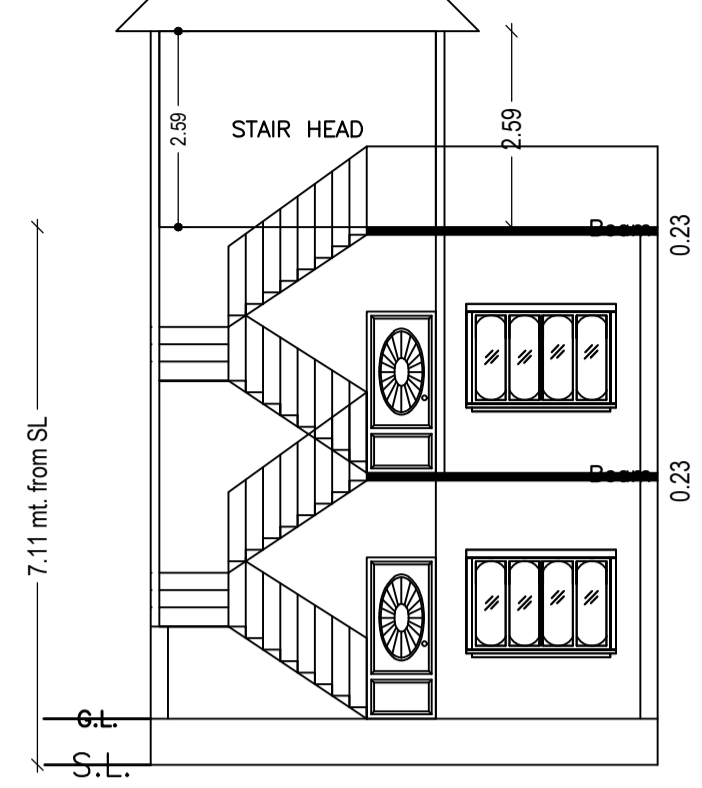

SECTION ON XX

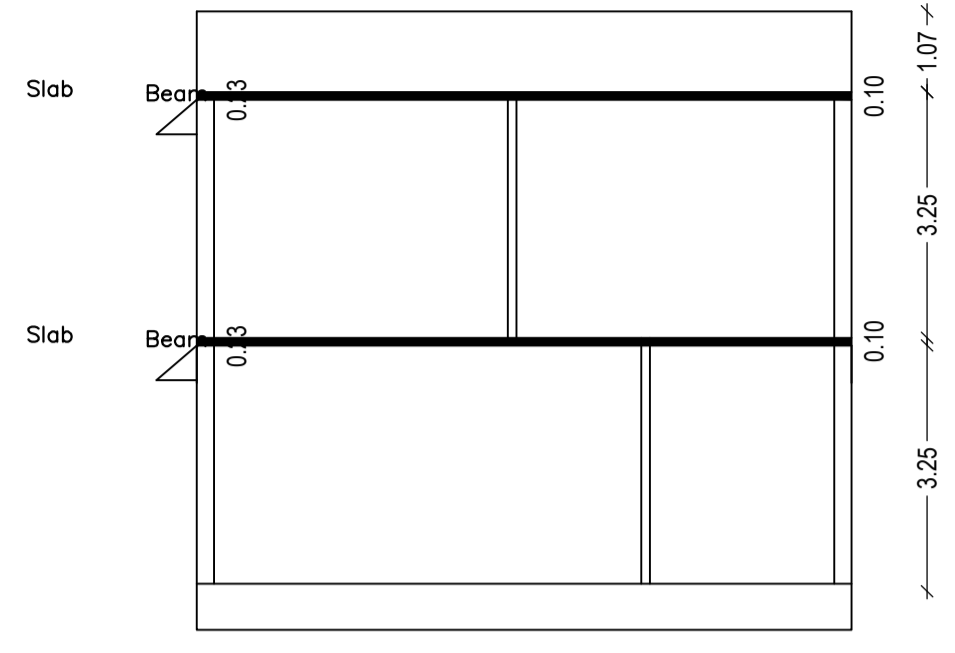

SECTION ON YY

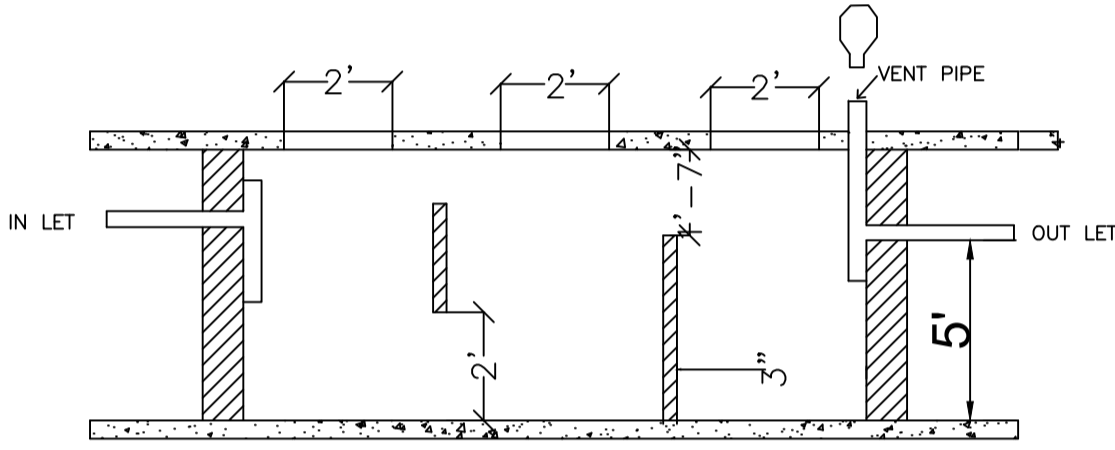

SECTION ON-X,X

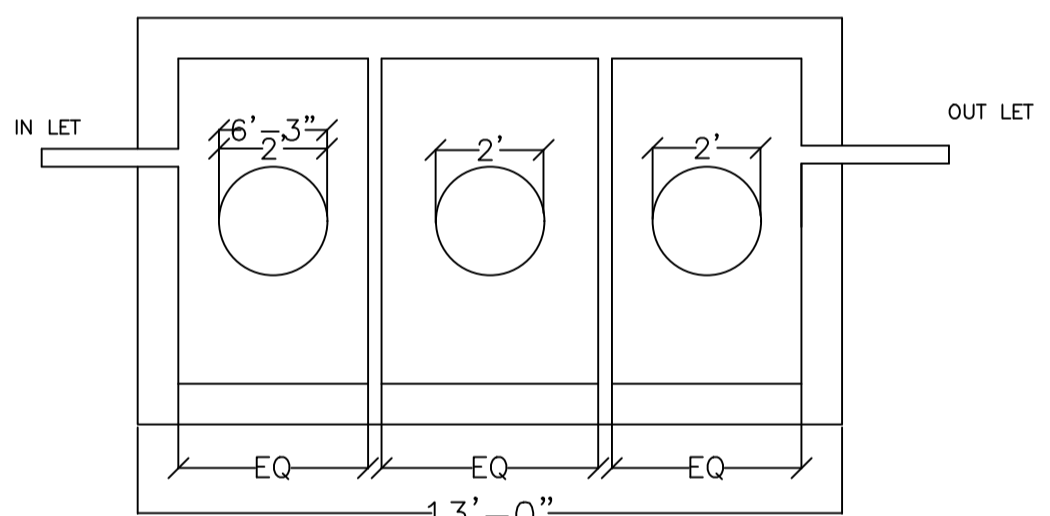

SEPTIC TANK

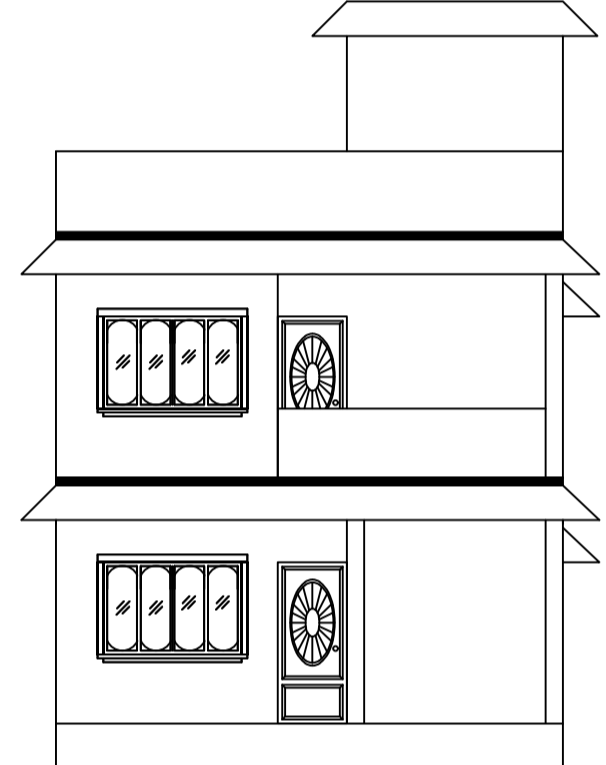

FRONT ELEVATION

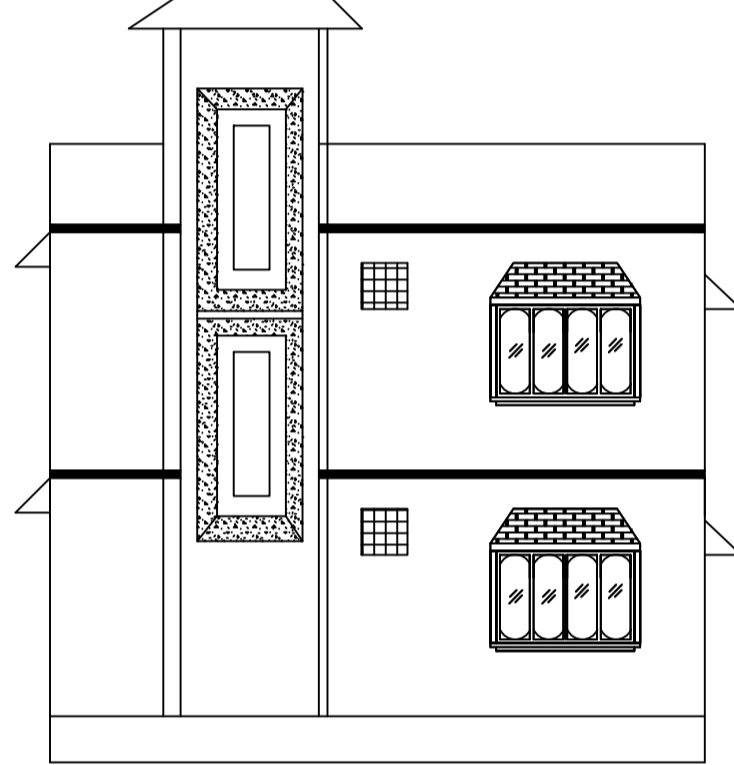

RIGHT SIDE ELEVATION

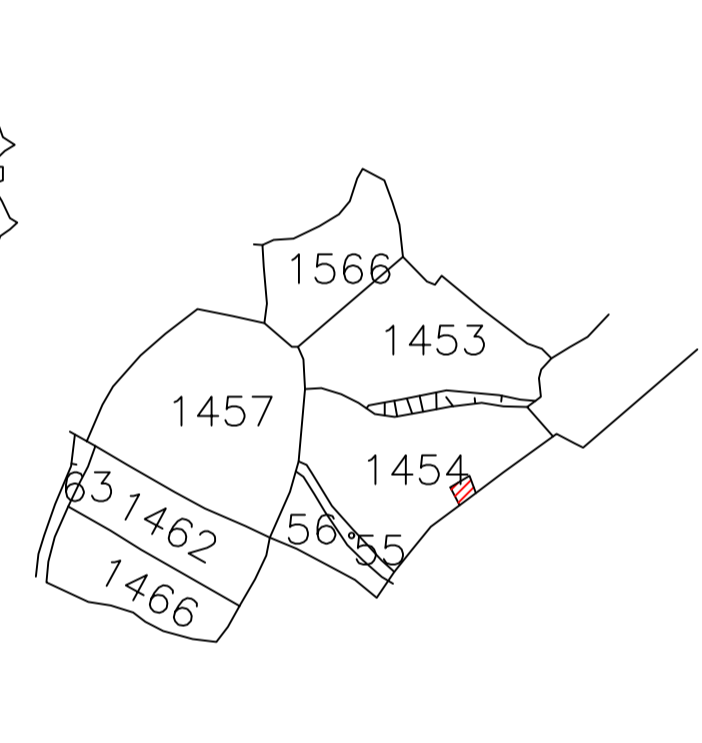

KEY PLAN
1"=330'

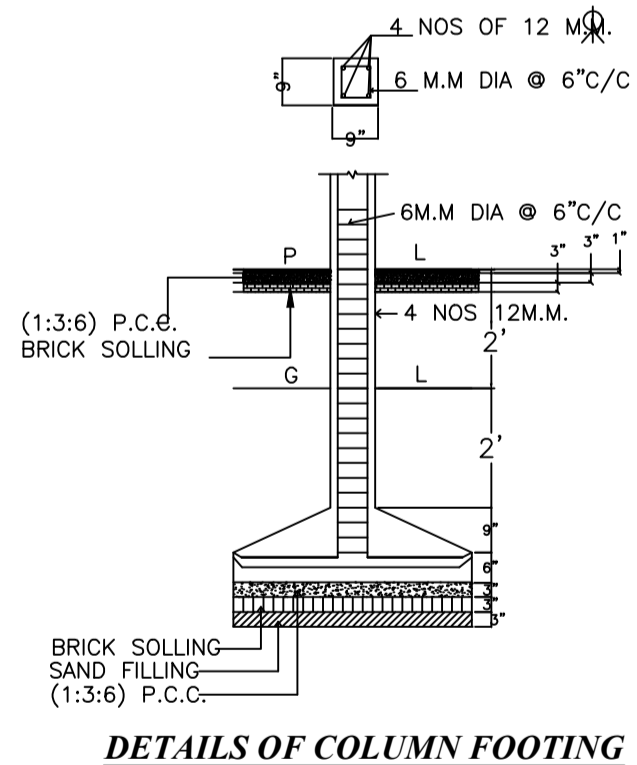

DETAILS OF COLUMN FOOTING

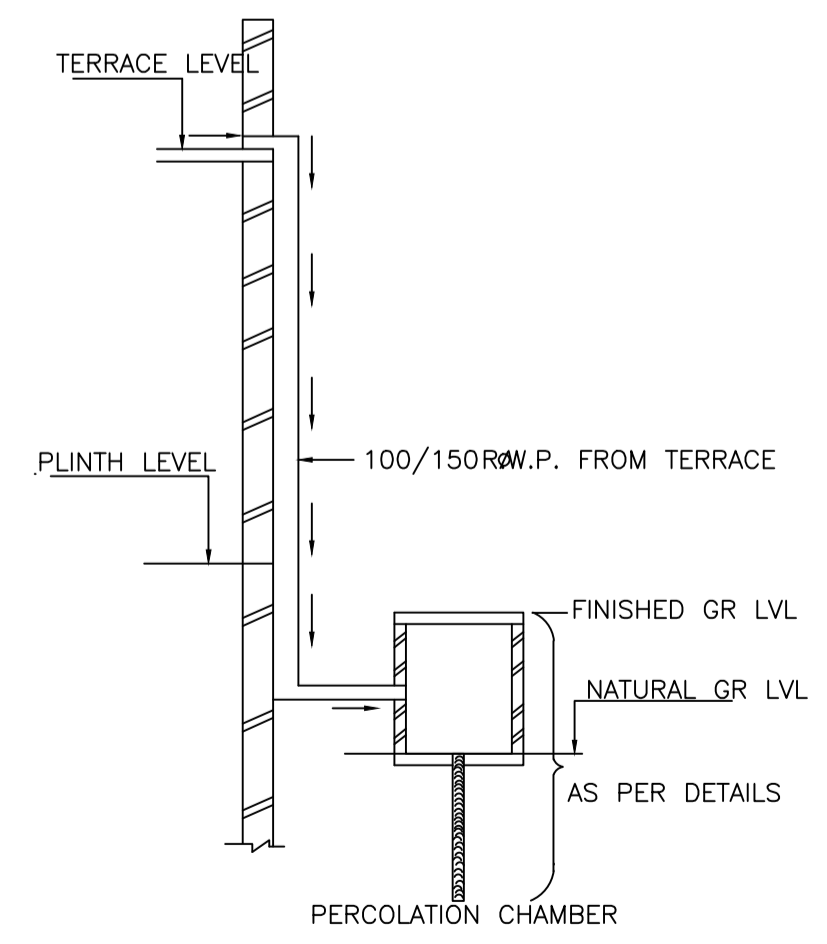

ROOF TOP RAIN WATER COLLECTION SYSTEM

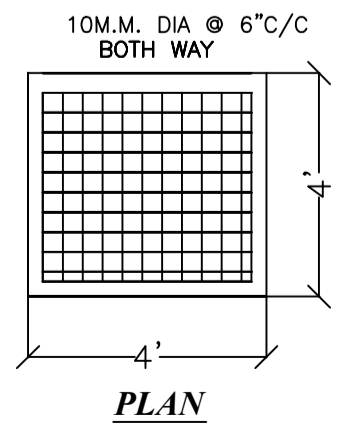

PLAN

SCHEDULE OF DOOR:

BUILDING NAME	NAME	LENGTH	HEIGHT	NOS
A (A)	D	0.76	2.10	03
A (A)	D	0.89	2.10	01
A (A)	D	0.91	2.10	03
A (A)	D	0.95	2.10	02
A (A)	D	0.97	2.10	01

SCHEDULE OF WINDOW/VENTILATION:

BUILDING NAME	NAME	LENGTH	HEIGHT	NOS
A (A)	V	0.61	1.20	02
A (A)	W	1.22	1.20	02
A (A)	W	1.83	1.20	06

Building :A (A)

Floor Name	Total Built Up Area (Sq.mt.)	Proposed FAR Area (Sq.mt.) Resi.	Total FAR Area (Sq.mt.)	Total Consumed Additional FAR Area (Sq.mt.)	Tnmt (No.)
Ground Floor	58.08	58.08	58.08	58.08	01
First Floor	58.08	58.08	58.08	58.08	00
Terrace Floor	0.00	0.00	0.00	0.00	00
Total :	116.16	116.16	116.16	116.16	01
Total Number of Same Buildings :	1				
Total :	116.16	116.16	116.16	116.16	01

COLOR INDEX

PLOT BOUNDARY	
ABUTTING ROAD	
PROPOSED CONSTRUCTION	
COMMON PLOT	
ROAD WIDENING AREA	
EXISTING (To be retained)	
EXISTING (To be demolished)	

Buildingwise Floor FAR Details

Floor Name	Building Name A (A)		Total	
	Proposed Built Up Area (Sq.mt.)	Proposed FAR Area (Sq.mt.)	Total Proposed Built Up Area (Sq.mt.)	Total FAR Area (Sq.mt.)
Ground Floor	58.08	58.08	58.08	58.08
First Floor	58.08	58.08	58.08	58.08
Terrace Floor	0.00	0.00	0.00	0.00
Total :	116.16	116.16	116.16	116.16

Building USE/SUBUSE Details

Building Name A (A)	Building Use Residential	Building SubUse		Building Structure Non-Highrise
		Residential Bldg/Apartment		

UnitBUA Table for Building :A (A)

FLOOR	Name	UnitBUA Type	UnitBUA Area	Carpet Area	No. of Rooms	No. of Tenement
GROUND FLOOR PLAN	SPLIT A	FLAT	116.16	116.06	5	1
FIRST FLOOR PLAN	SPLIT A	FLAT	0.00	0.00	6	0
Total:	-	-	116.16	116.06	11	1

FAR & Tenement Details (Table 4c-1)

Building	No. of Same Bldg	Total Built Up Area (Sq.mt.)	Proposed FAR Area (Sq.mt.) Resi.	Total FAR Area (Sq.mt.)	Total Consumed Additional FAR Area (Sq.mt.)	Tnmt (No.)
A (A)	1	116.16	116.16	116.16	116.16	01
Grand Total :	1	116.16	116.16	116.16	116.16	01

LTP NAME AND SIGNATURE	STRUCTURAL ENG'S NAME AND SIGNATURE	BUILDER NAME AND SIGNATURE	DIGITAL SIGNATURE
SANTOSH MADA/ENG/0022/2019			

Proposal Basic Information	
Proposal File No.	MADA/BP/0170/2021
Owner Name	(1) SMT. GEETA SINGH (2) SMT. NIDHI SINGH
Khata No	OLD- 74, NEW- 64
Plot No	OLD- 1454, NEW- 1633
Village Name	Nawadhi
Use	Residential
SubUse	Bungalow/ Dwelling / Non Apartment

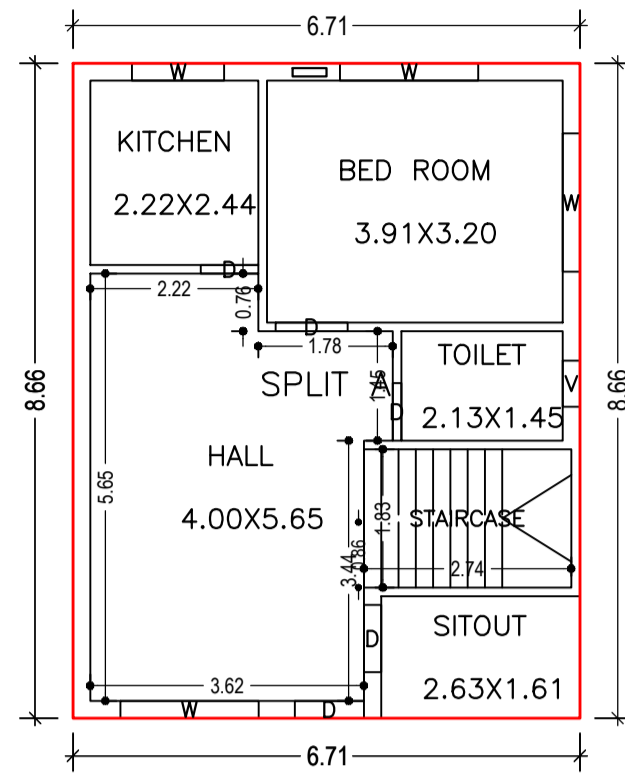

GROUND FLOOR PLAN
(Proposed)
(SCALE 1:100)

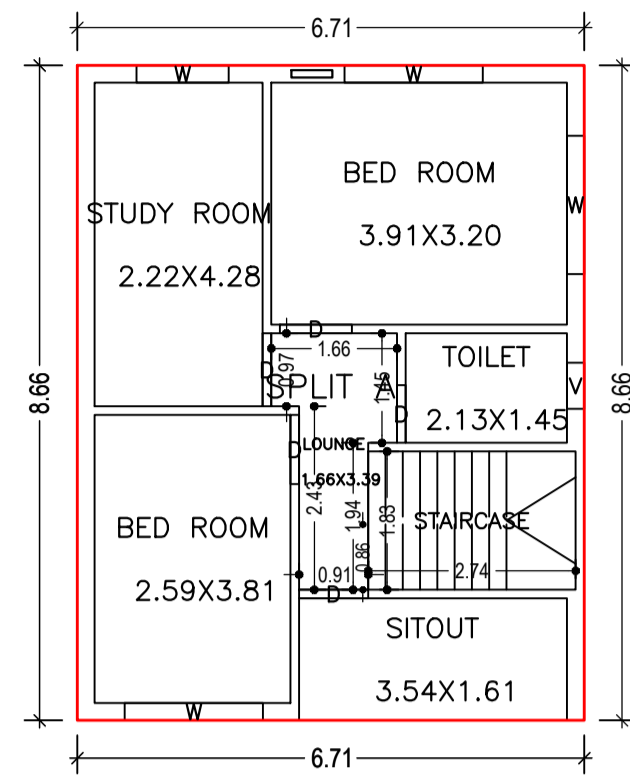

FIRST FLOOR PLAN
(Proposed)
(SCALE 1:100)

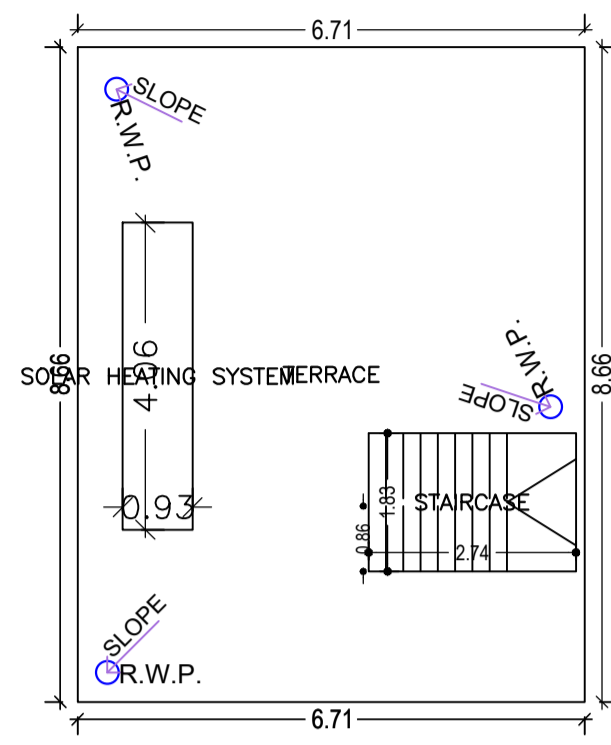

TERRACE FLOOR PLAN
(SCALE 1:100)

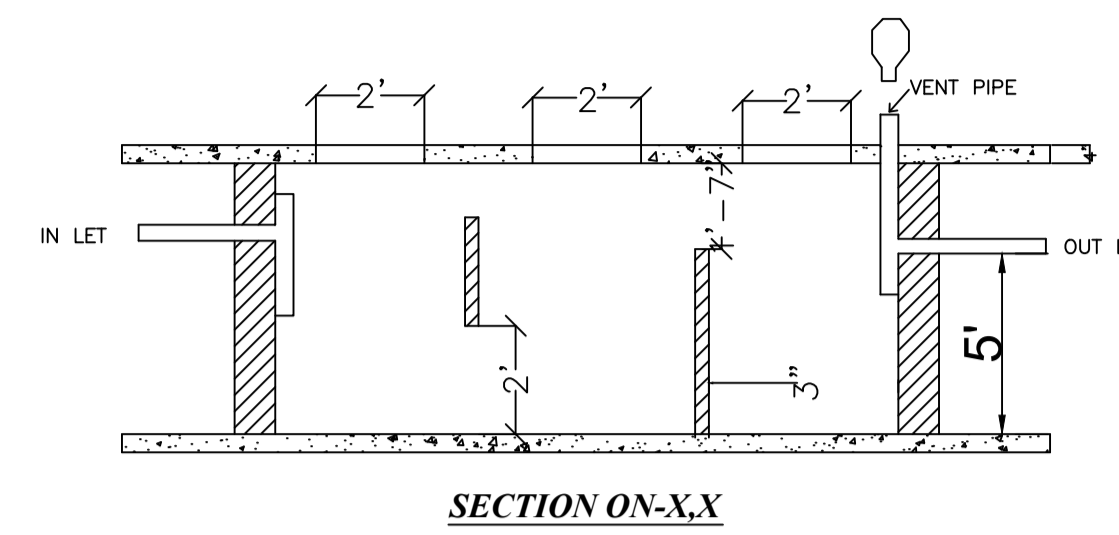

SECTION ON-X-X

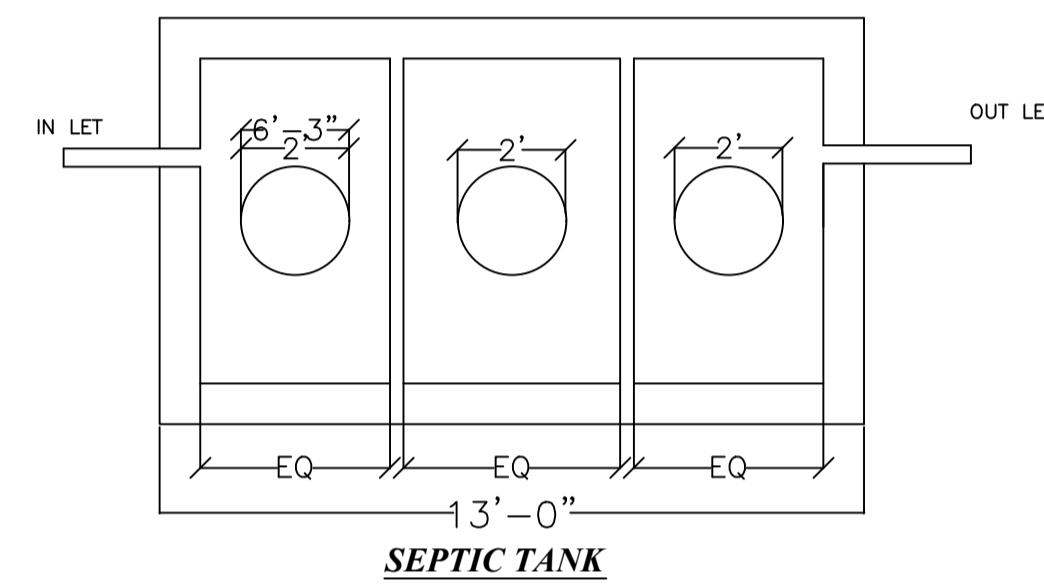

SEPTIC TANK

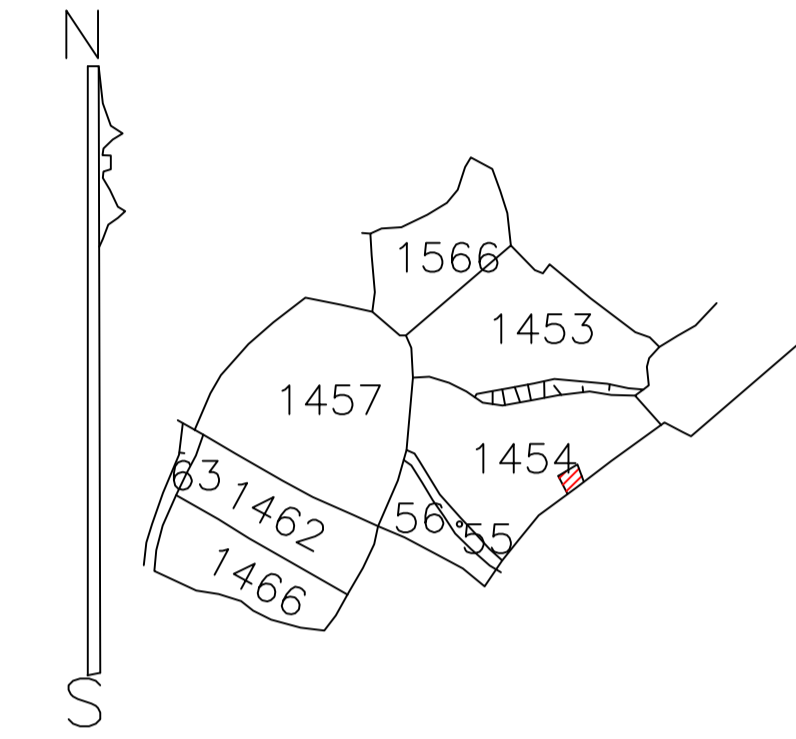

KEY PLAN
1"=330'

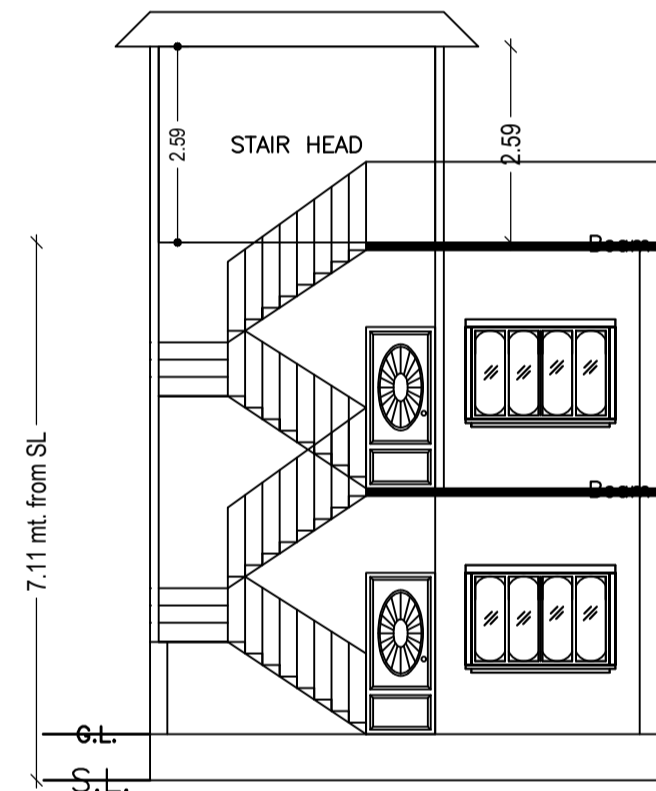

SECTION ON XX

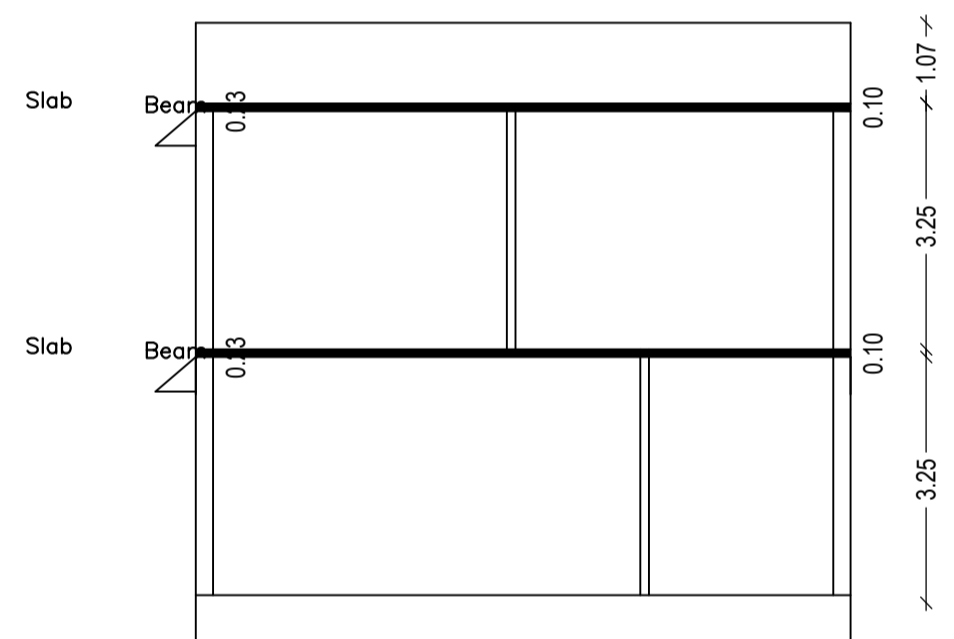

SECTION ON YY

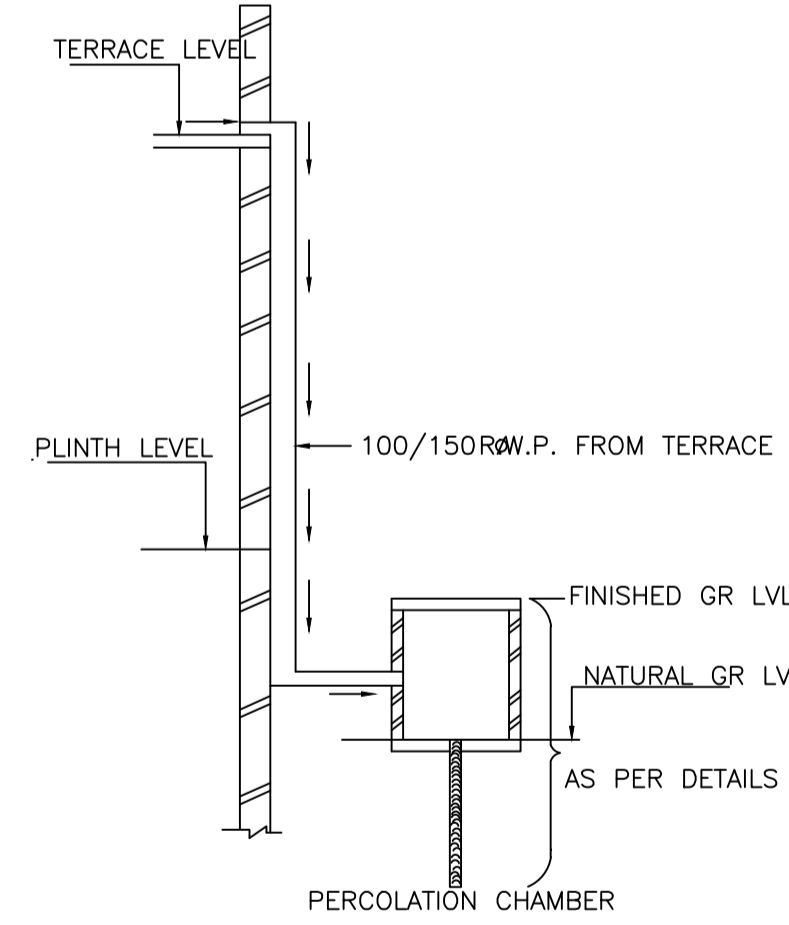

ROOF TOP RAIN WATER
COLLECTION SYSTEM

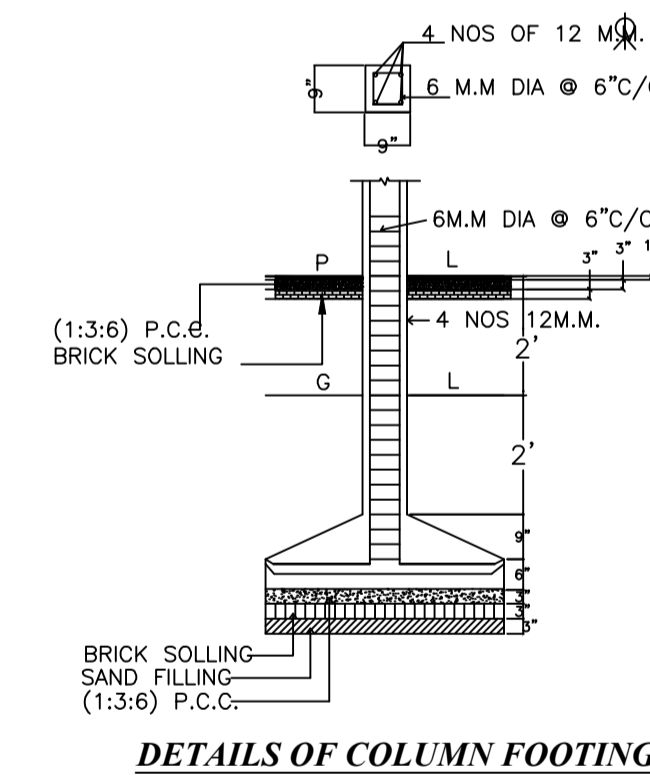

DETAILS OF COLUMN FOOTING

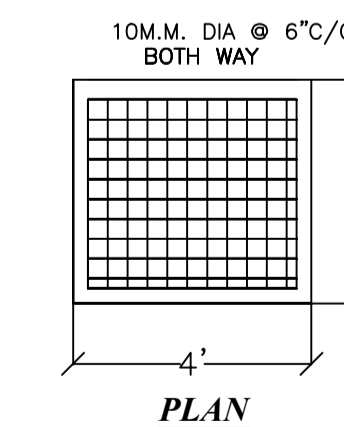

PLAN

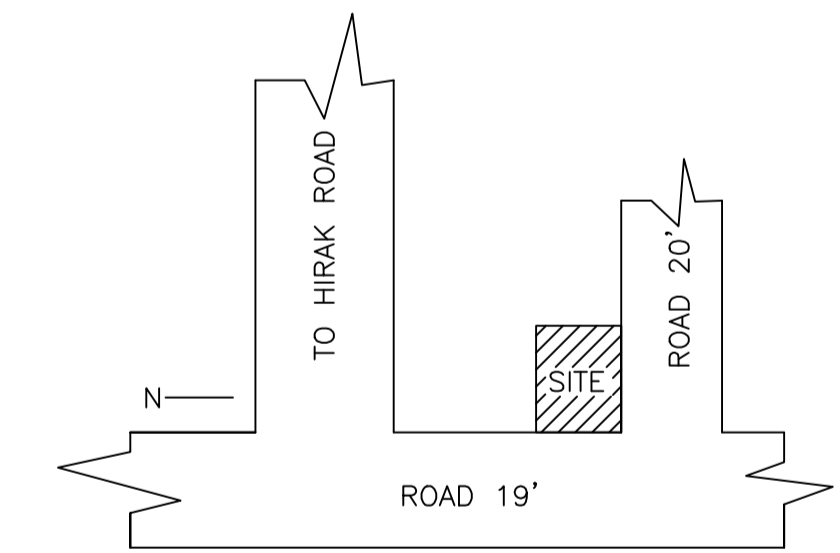

LOCATION PLAN

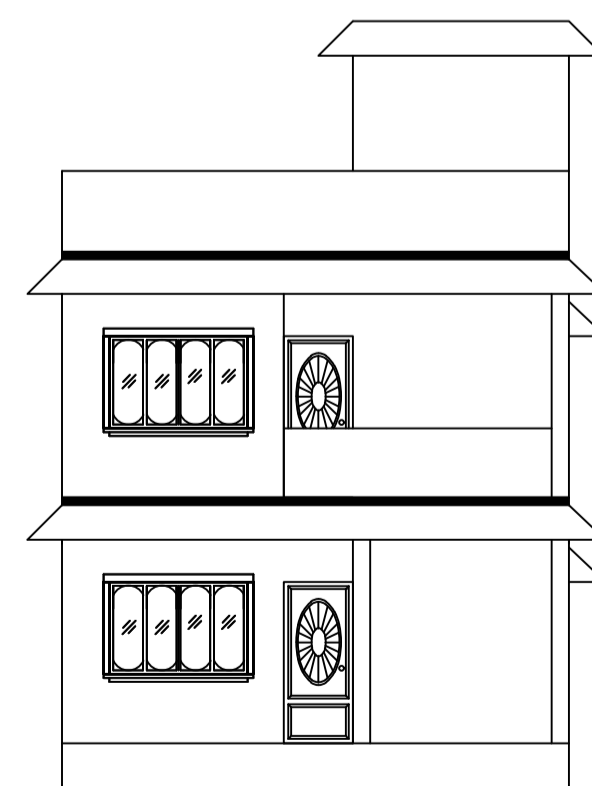

FRONT ELEVATION

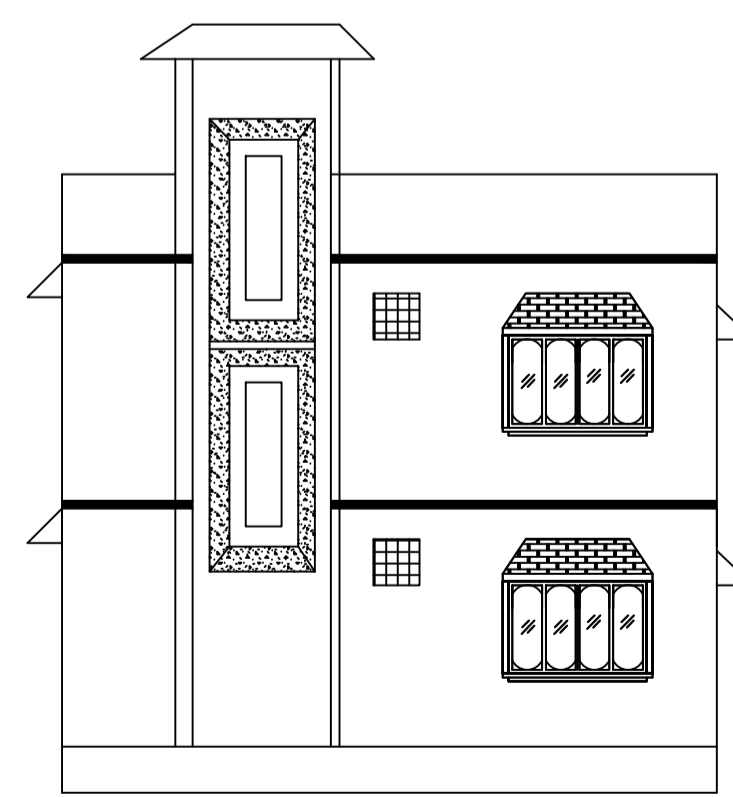

RIGHT SIDE ELEVATION

LTP NAME AND SIGNATURE	STRUCTURAL ENG'S NAME AND SIGNATURE	BUILDER NAME AND SIGNATURE	DIGITAL SIGNATURE
SANTOSH MADA/ENG/0022/2019			