

Proposal Basic Information

Proposal File No.	MADA/BP/0299/2021
Owner Name	SMT. SUSHMA GUPTA
Khata No	OLD KHATA NO-25, NEW KHATA NO-35
Plot No	OLD PLOT NO. 2537, NEW PLOT NO. 3901
Village Name	Bara Pichri
Use	Residential
SubUse	Bungalow/ Dwelling / Non Apartment

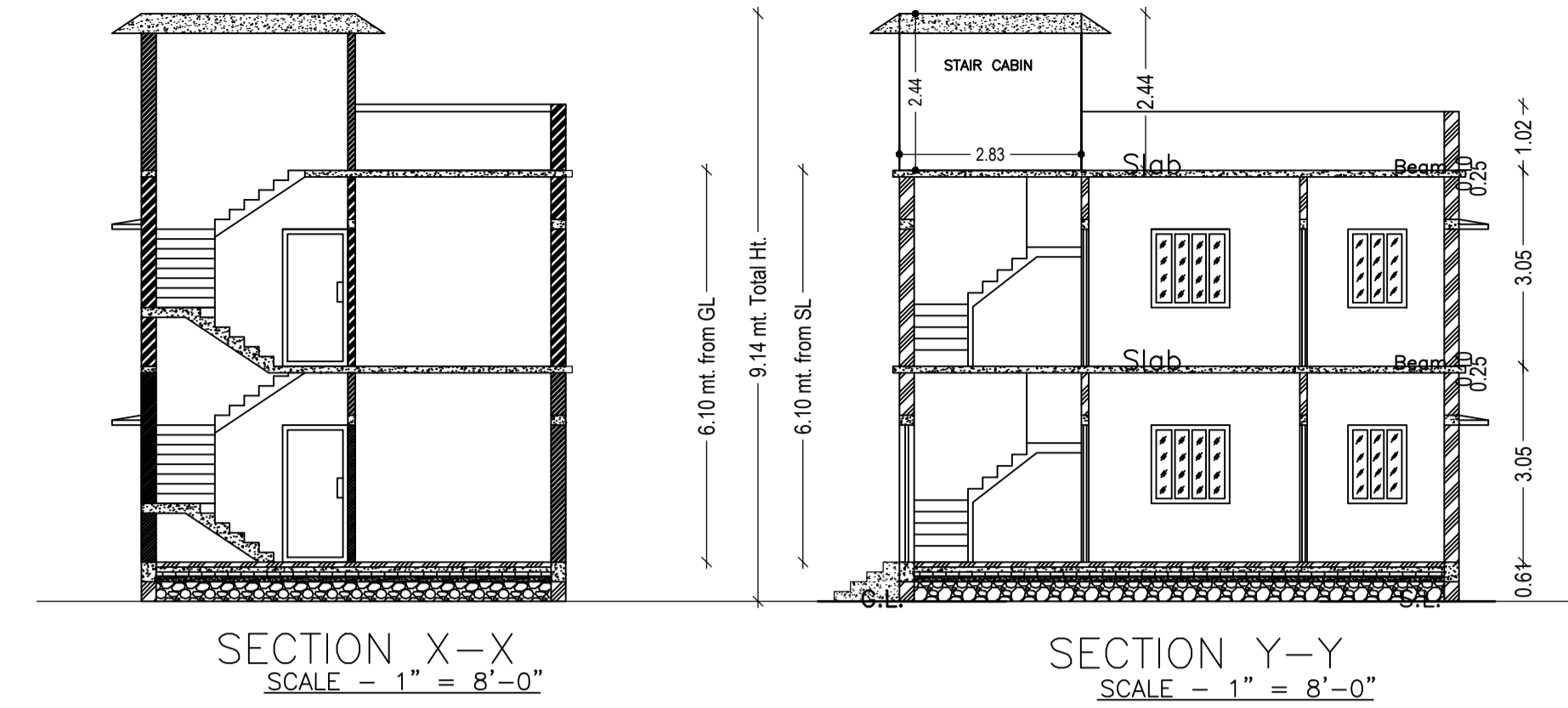

**SITE PLAN**  
SCALE - 1" = 16'-0"

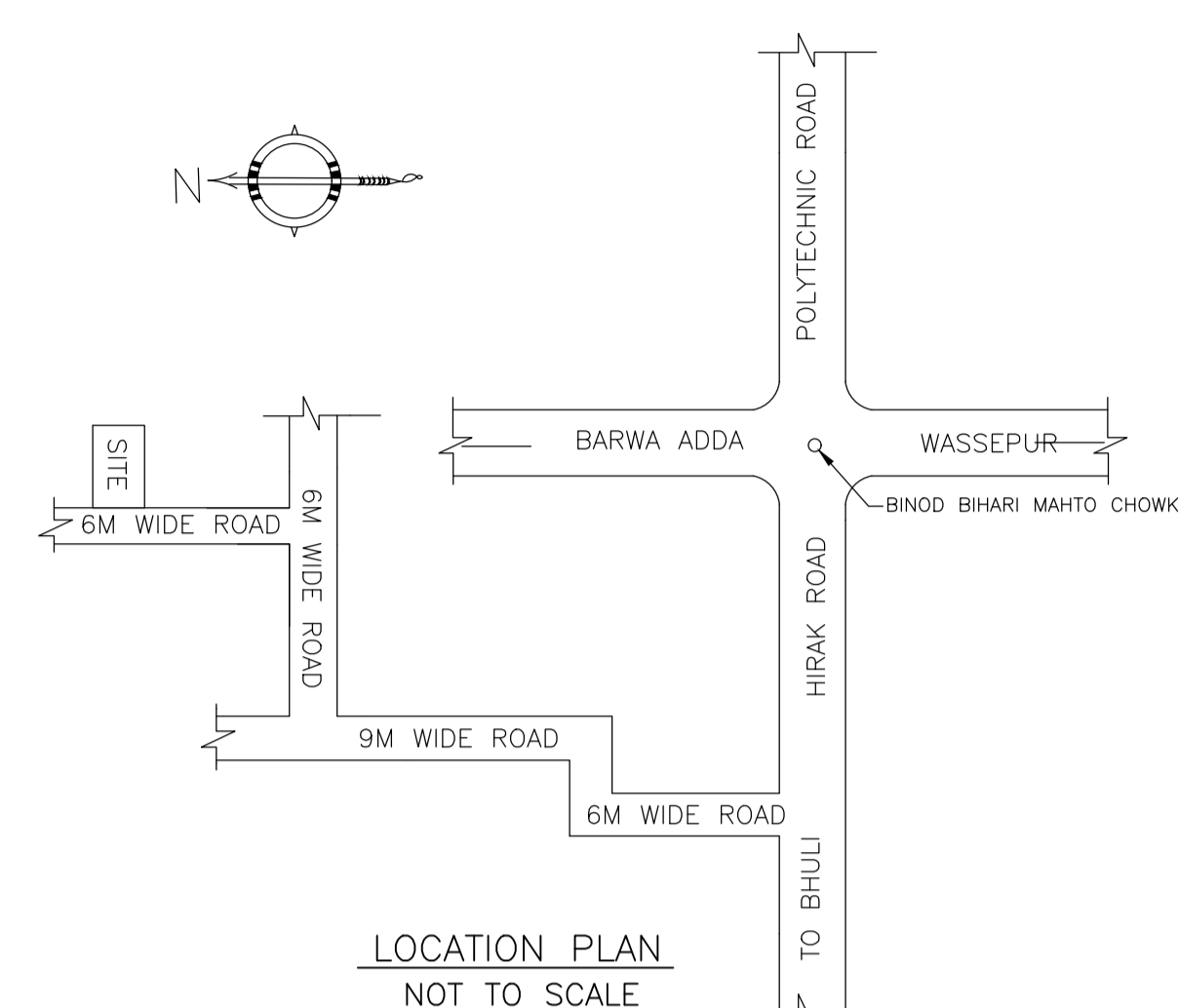
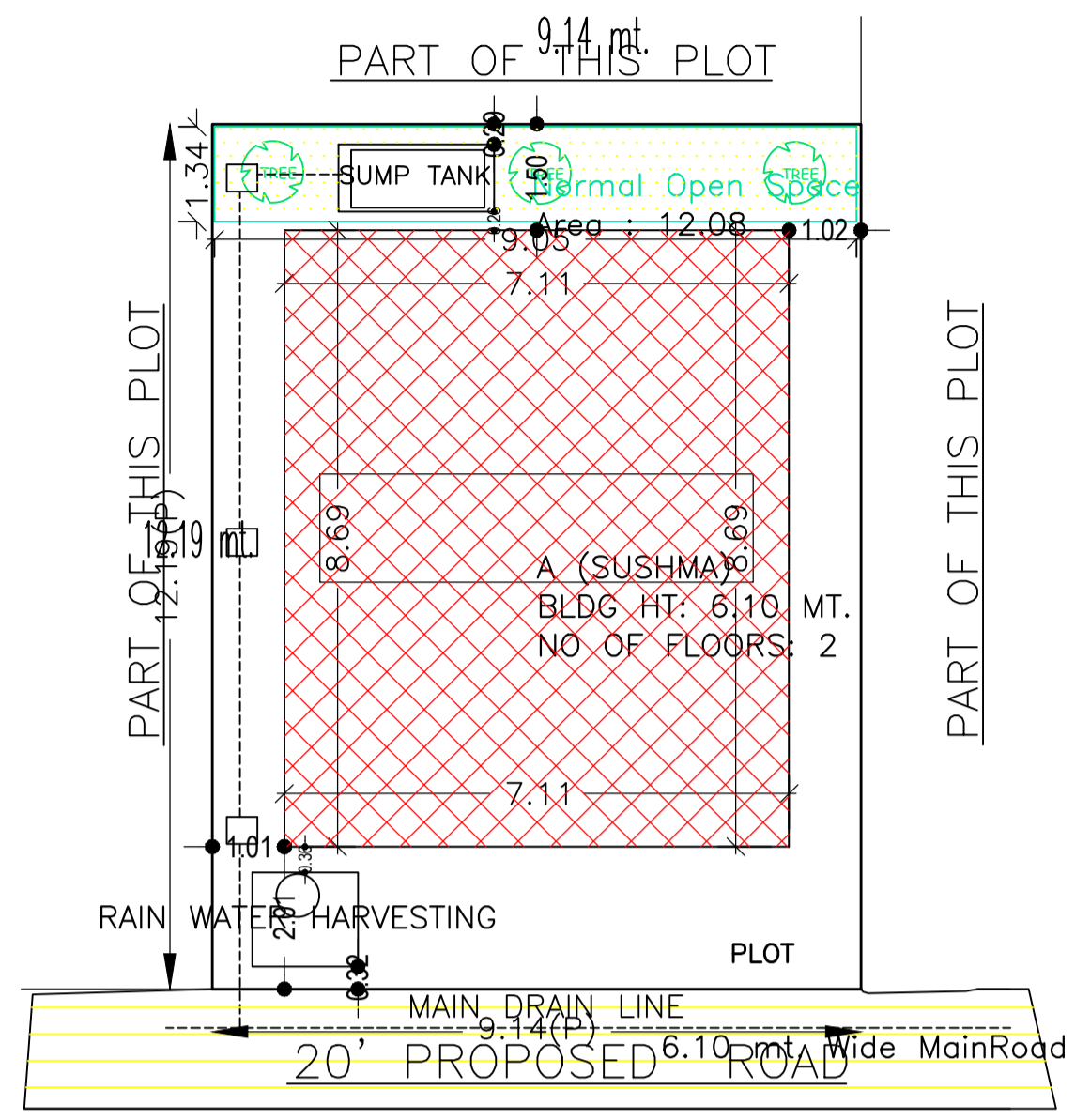
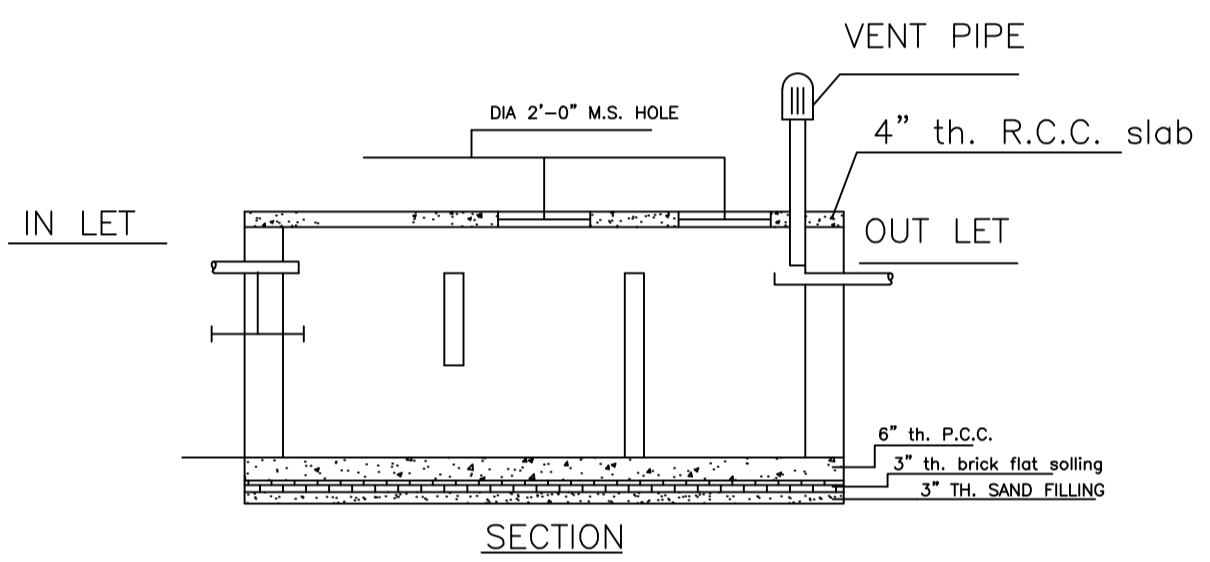

**DETAILS OF SEPTIC TANK**  
SCALE - 1" = 4'-0"

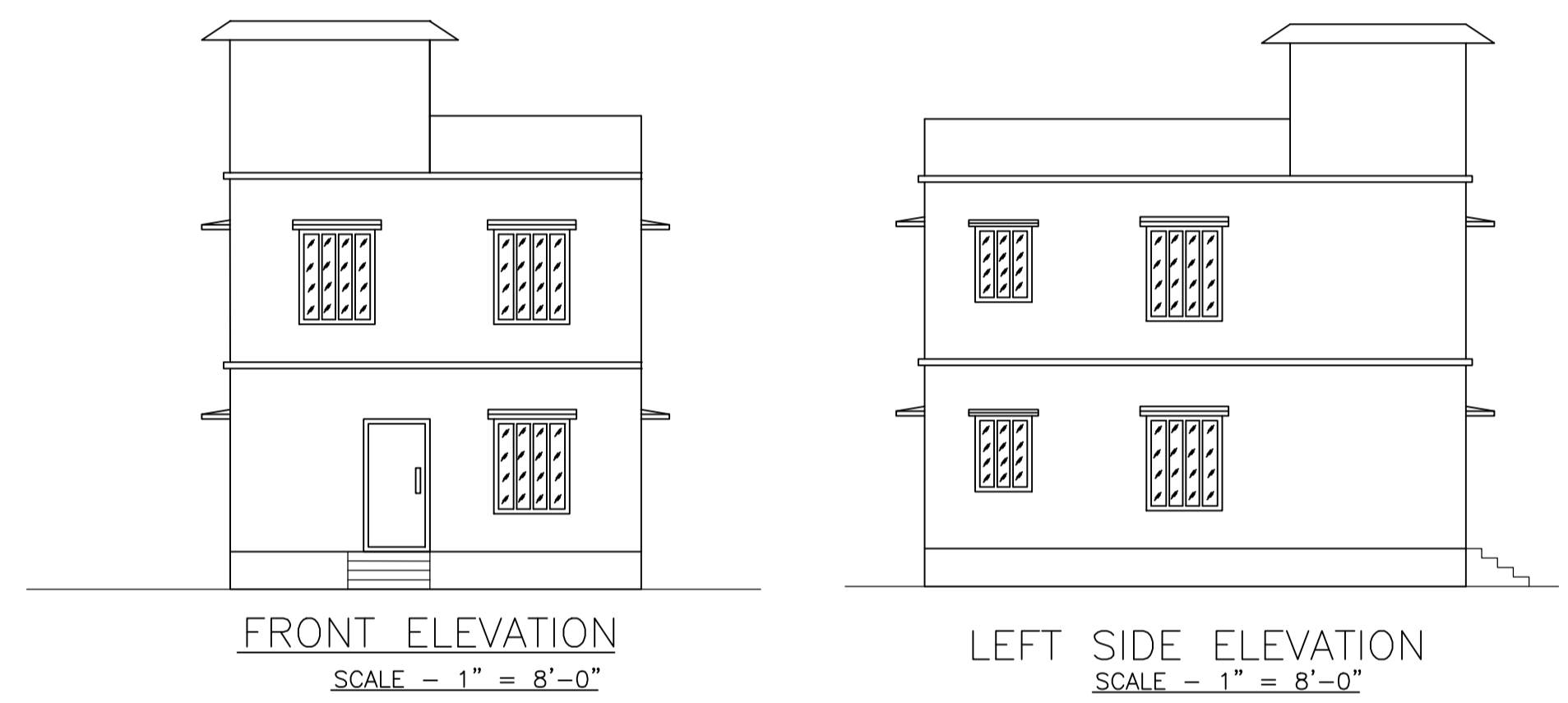

**FRONT ELEVATION**  
SCALE - 1" = 8'-0"

**LEFT SIDE ELEVATION**  
SCALE - 1" = 8'-0"

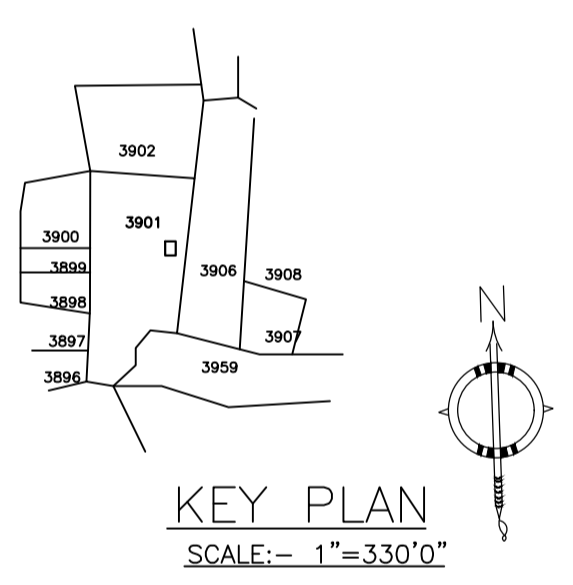

**KEY PLAN**  
SCALE:- 1" = 33'0"

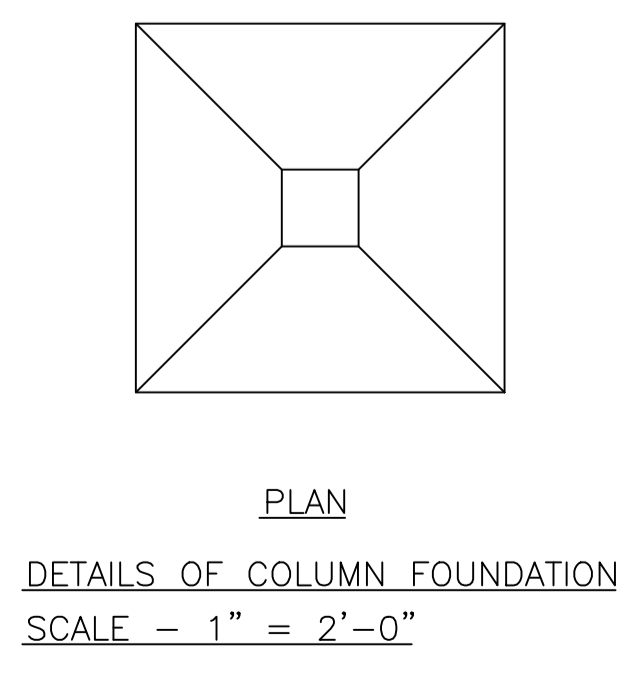
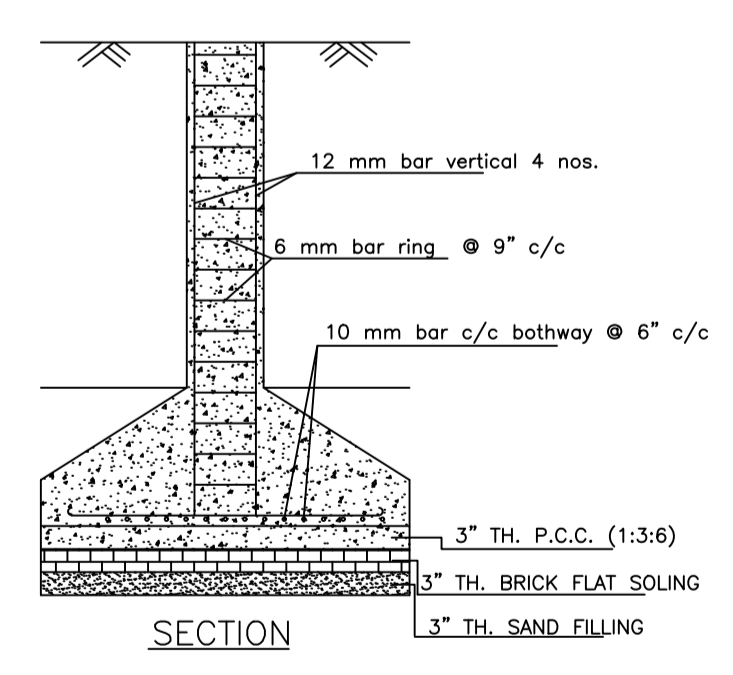

**DETAILS OF COLUMN FOUNDATION**  
SCALE - 1" = 2'-0"

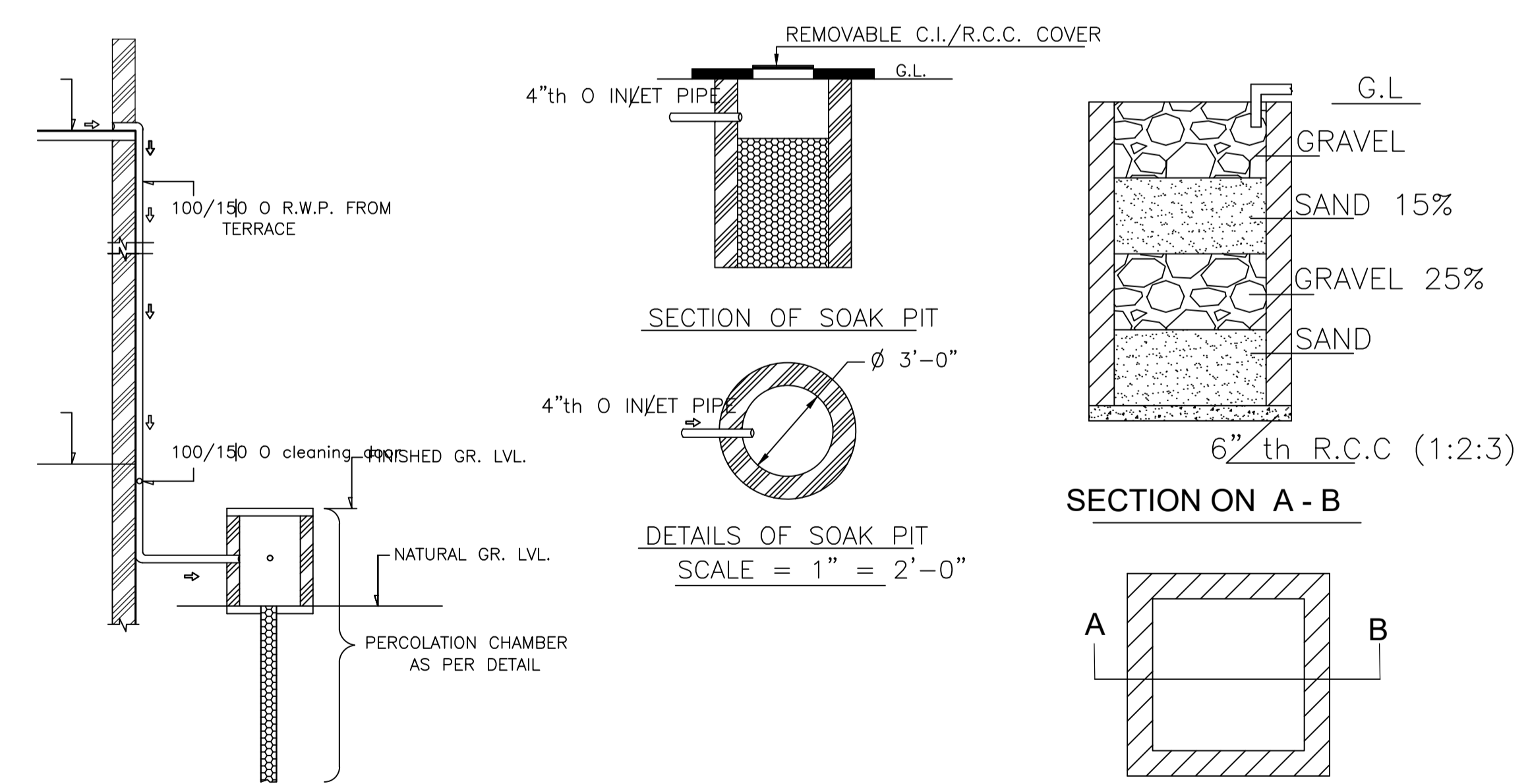

**ROOF TOP RAIN WATER COLLECTION SYSTEM**  
SCALE = 1" = 4'-0"

**SECTION ON A - B**

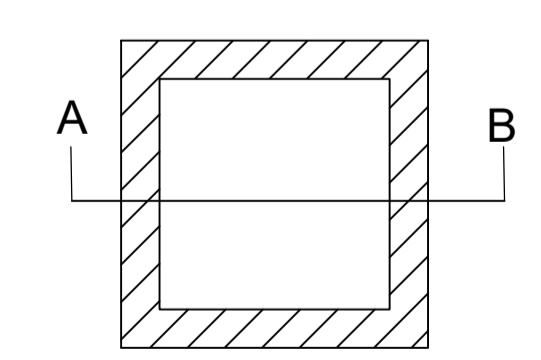

**DETAILS DRAWING OF RAIN WATER HARVESTING**  
SCALE:- 1"=2'-0"

AREA STATEMENT MINERAL AREA DEVELOPMENT AUTHORITY	VERSION NO.: 1.0.61 VERSION DATE: 16/10/2020	
PROJECT DETAIL:		
Region: JHARKHAND URBAN LOCAL BODIES	Plot Use: Residential	
District: DHANBAD	Plot SubUse: Bungalow/ Dwelling / Non Apartment	
Authority: MINERAL AREA DEVELOPMENT AUTHORITY	PlotNearby/ReligiousStructure: NA	
Application No: MADA/BP/0299/2021	Plot/SubPlot No: OLD PLOT NO. 2537, NEW PLOT NO. 3901	
Project Type: Building Permission	North: Plot No. - SAME PLOT	
Nature of Development: New	South: Plot No. - SAME PLOT	
Location of Development Area: Old Area	East: Plot No. - SAME PLOT	
	West: Road Width - 6.10	
AREA DETAILS:		
AREA OF PLOT (Minimum)	(A)	SQ.MT.
NET AREA OF PLOT (Gross Plot Area - Deduction from Gross Plot area)	(A-Deductions)	111.39
Deduction for Balance Plot Area (from Gross Plot Area)		
Common Plot		12.08
Total		12.08
BALANCE AREA OF PLOT (Net Plot Area - Recreational/Amenity spaces)	(A-Deductions)	99.30
PLOT AREA FOR COVERAGE (Net Plot Area)	(A-Deductions)	111.39
Plot Area for FAR (Net Plot Area + Road Widening Area)	(A-Deductions)	111.39
COVERAGE CHECK		
Permissible Coverage area (70.00 %)		77.97
Proposed Coverage Area (55.45 %)		61.76
Total Prop. Coverage Area (55.45 %)		61.76
Balance coverage area (14.55 %)		16.21
FAR CHECK		
Perm. FAR Area (2.50)		278.48
Total Perm. FAR area		278.48
Residential FAR		123.52
Proposed FAR Area		123.52
Total Proposed FAR Area		123.52
Consumed FAR (Factor)		1.11
Balance FAR Area		154.96
BUILT UP AREA CHECK		
Total Proposed BuiltUp Area		123.52
ARCHITECT (Regd)		RAM PRATAP SINGH
ENGINEER (Regd)		
SUPERVISOR (Regd)		
OWNER (Regd)		SMT. SUSHMA GUPTA
DEVELOPMENT AUTHORITY		LOCAL BODY

COLOR INDEX		
PLOT BOUNDARY		Black
ABUTTING ROAD		Green
PROPOSED CONSTRUCTION		Red
COMMON PLOT		Yellow
ROAD WIDENING AREA		Blue
EXISTING (To be retained)		Light Blue
EXISTING (To be demolished)		Dark Blue

Buildingwise Floor FAR Details

Floor Name	Building Name A (SUSHMA)		Total	
	Proposed Built Up Area (Sq.mt.)	Proposed FAR Area (Sq.mt.)	Total Proposed Built Up Area (Sq.mt.)	Total FAR Area (Sq.mt.)
Ground Floor	61.76	61.76	61.76	61.76
First Floor	61.76	61.76	61.76	61.76
Terrace Floor	0.00	0.00	0.00	0.00
Total :	123.52	123.52	123.52	123.52

Building USE/SUBUSE Details

Building Name	Building Use	Building SubUse	Building Structure
A (SUSHMA)	Residential	Residential Bldg/Apartment	Non-Highrise

UnitBUA Table for Building :A (SUSHMA)

FLOOR	Name	UnitBUA Type	UnitBUA Area	Carpet Area	No. of Rooms	No. of Tenement
GROUND FLOOR PLAN	SPLIT 1	FLAT	123.52	121.65	5	1
	FIRST FLOOR PLAN	SPLIT 1	FLAT	0.00	0.00	5
Total:	-	-	123.52	121.65	10	1

FAR & Tenement Details (Table 4c-1)

Building	No. of Same Bldg	Total Built Up Area (Sq.mt.)	Proposed FAR Area (Sq.mt.) Resi.	Total FAR Area (Sq.mt.)	Total Consumed Additional FAR Area (Sq.mt.)	Tnmt (No.)
A (SUSHMA)	1	123.52	123.52	123.52	123.52	01
Grand Total :	1	123.52	123.52	123.52	123.52	01

SCHEDULE OF DOOR:

BUILDING NAME	NAME	LENGTH	HEIGHT	NOS
A (SUSHMA)	D	0.76	2.10	02
A (SUSHMA)	D	0.88	2.10	02
A (SUSHMA)	D	0.91	2.10	04
A (SUSHMA)	D	1.02	2.10	02

SCHEDULE OF WINDOW/VENTILATION:

BUILDING NAME	NAME	LENGTH	HEIGHT	NOS
A (SUSHMA)	V	0.61	1.20	02
A (SUSHMA)	W	0.91	1.20	04
A (SUSHMA)	W	1.22	1.20	10

Building :A (SUSHMA)

Floor Name	Total Built Up Area (Sq.mt.)	Proposed FAR Area (Sq.mt.) Resi.	Total FAR Area (Sq.mt.)	Total Consumed Additional FAR Area (Sq.mt.)	Tnmt (No.)
Ground Floor	61.76	61.76	61.76	61.76	01
First Floor	61.76	61.76	61.76	61.76	00
Terrace Floor	0.00	0.00	0.00	0.00	00
Total :	123.52	123.52	123.52	123.52	01
Total Number of Same Buildings :	1				
Total :	123.52	123.52	123.52	123.52	01

LTP NAME AND SIGNATURE	STRUCTURAL ENG'S NAME AND SIGNATURE	BUILDER NAME AND SIGNATURE	DIGITAL SIGNATURE
RAM PRATAP SINGH MADA/ARC/0024/2019			

Proposal Basic Information

Proposal File No.	MADA/BP/0299/2021
Owner Name	SMT. SUSHMA GUPTA
Khata No	OLD KHATA NO-25,NEW KHATA NO-35
Plot No	OLD PLOT NO. 2537, NEW PLOT NO. 3901
Village Name	Bara Pichri
Use	Residential
SubUse	Bungalow/ Dwelling / Non Apartment

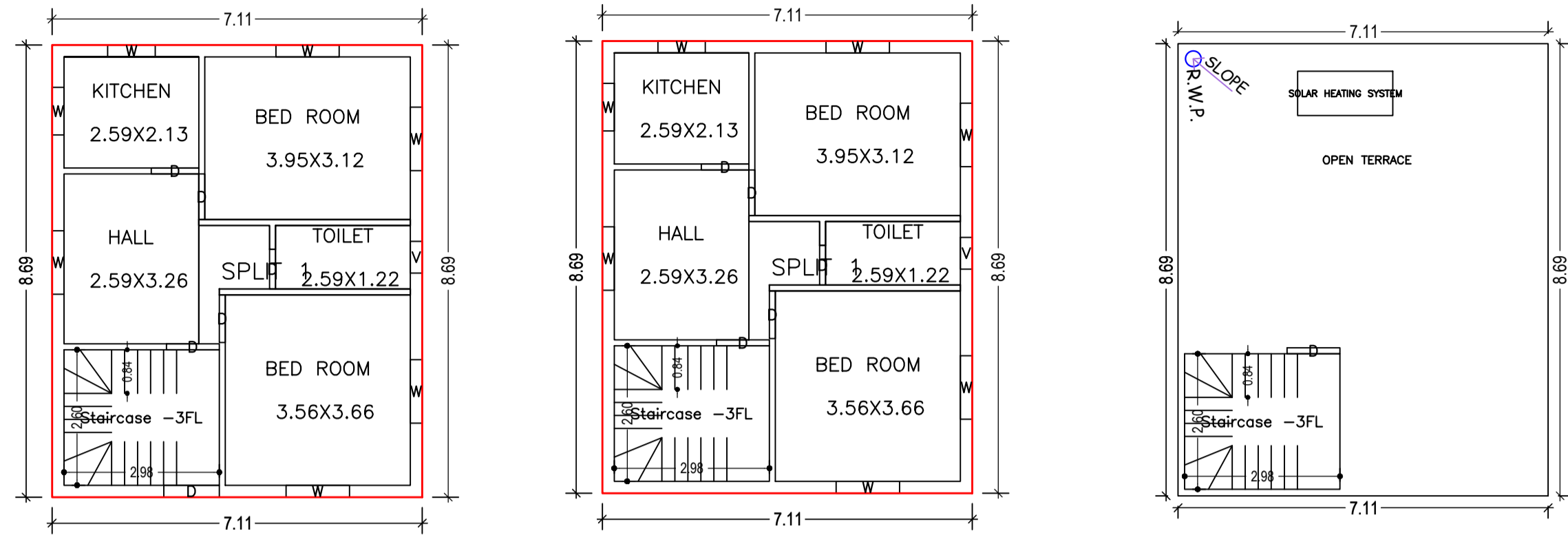

GROUND FLOOR PLAN  
(Proposed)  
SCALE 1:100

FIRST FLOOR PLAN  
(Proposed)  
SCALE 1:100

TERRACE FLOOR PLAN  
(SCALE 1:100)

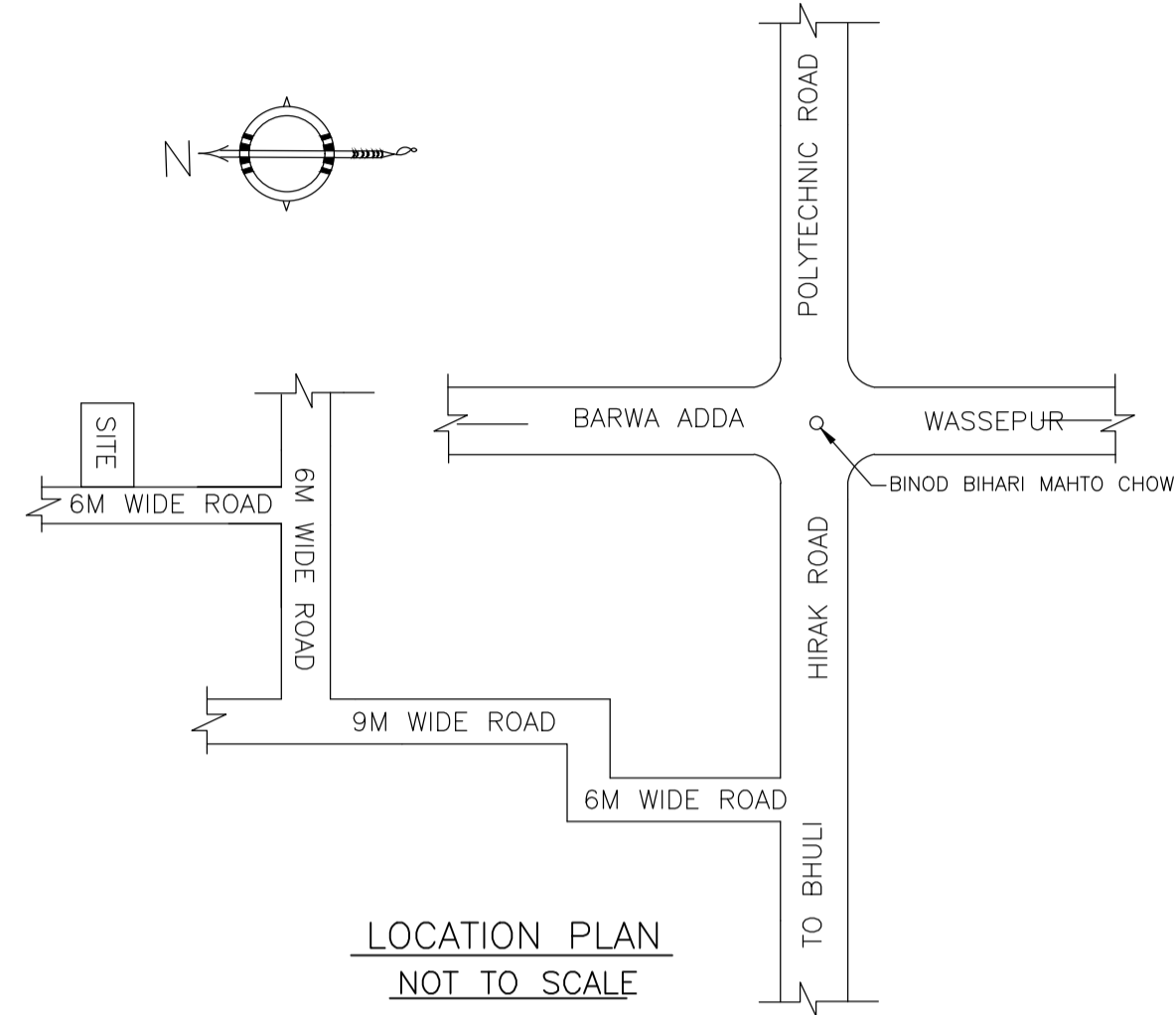

LOCATION PLAN  
NOT TO SCALE

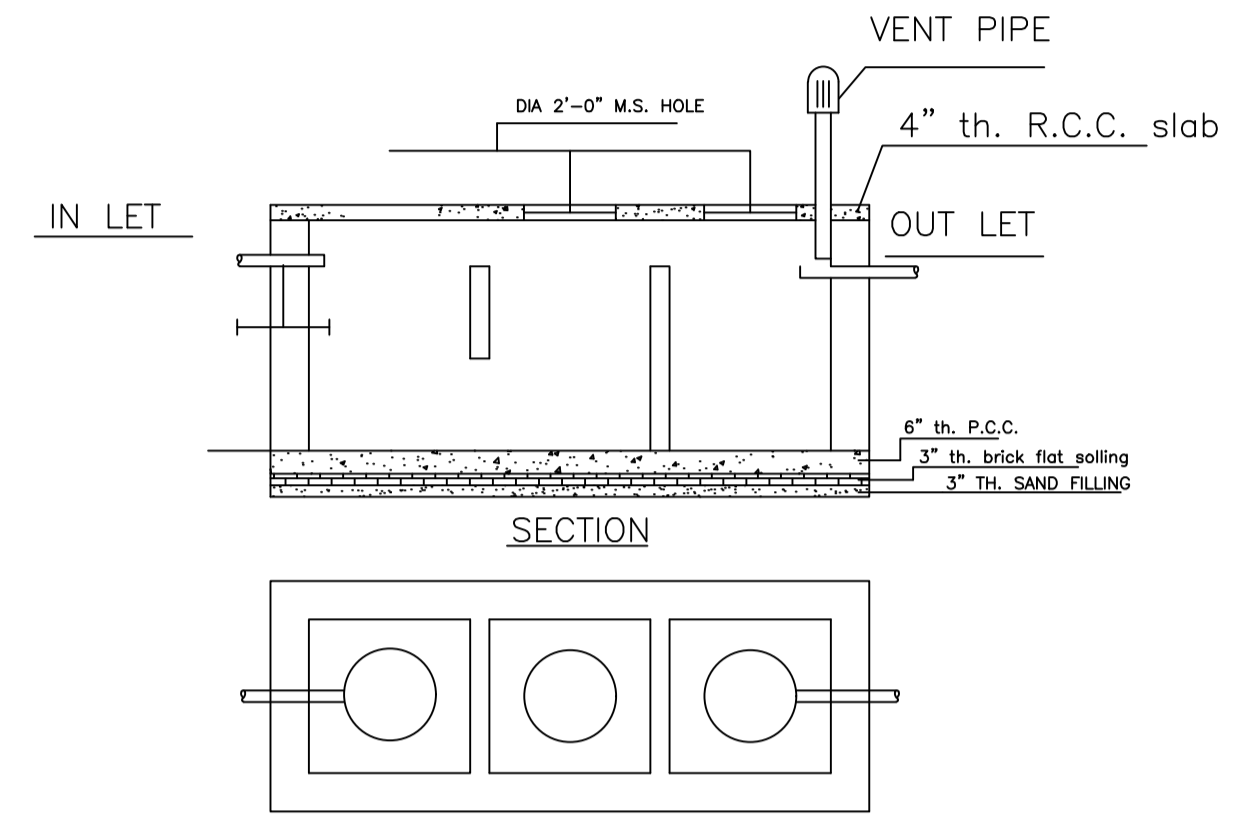

DETAILS OF SEPTIC TANK  
SCALE - 1" = 4'-0"

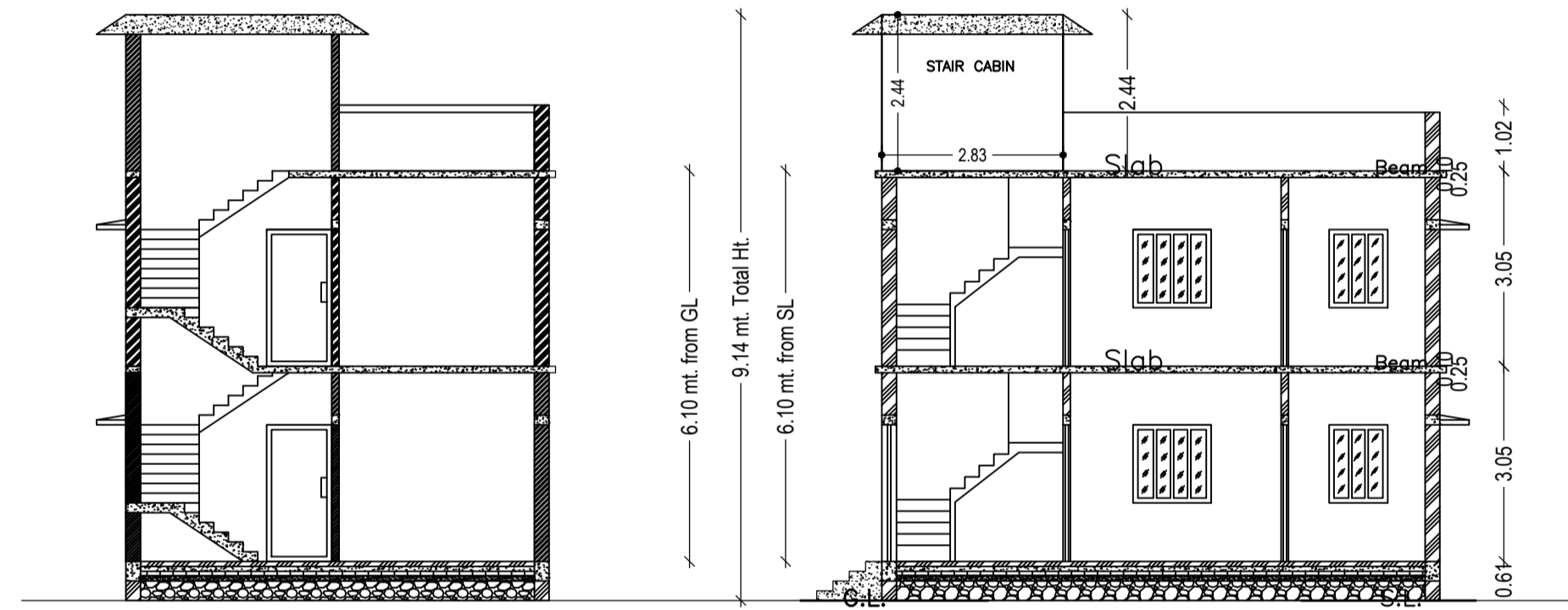
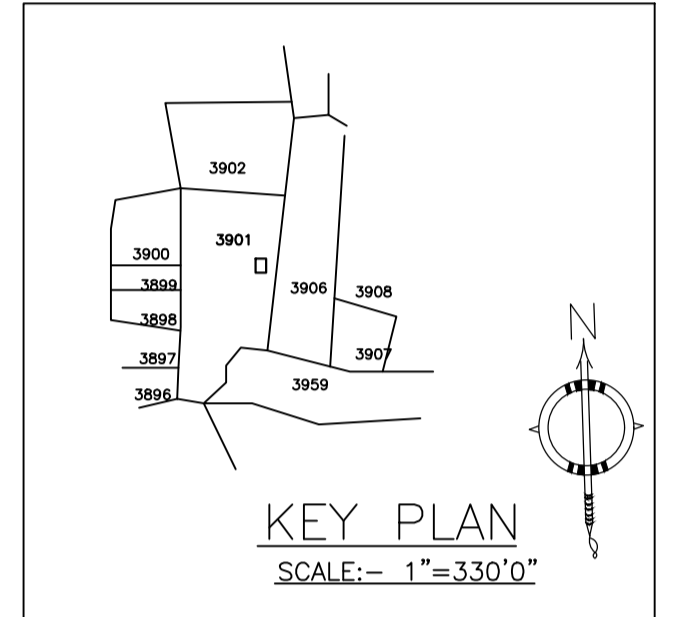

SECTION X-X  
SCALE - 1" = 8'-0"

SECTION Y-Y  
SCALE - 1" = 8'-0"

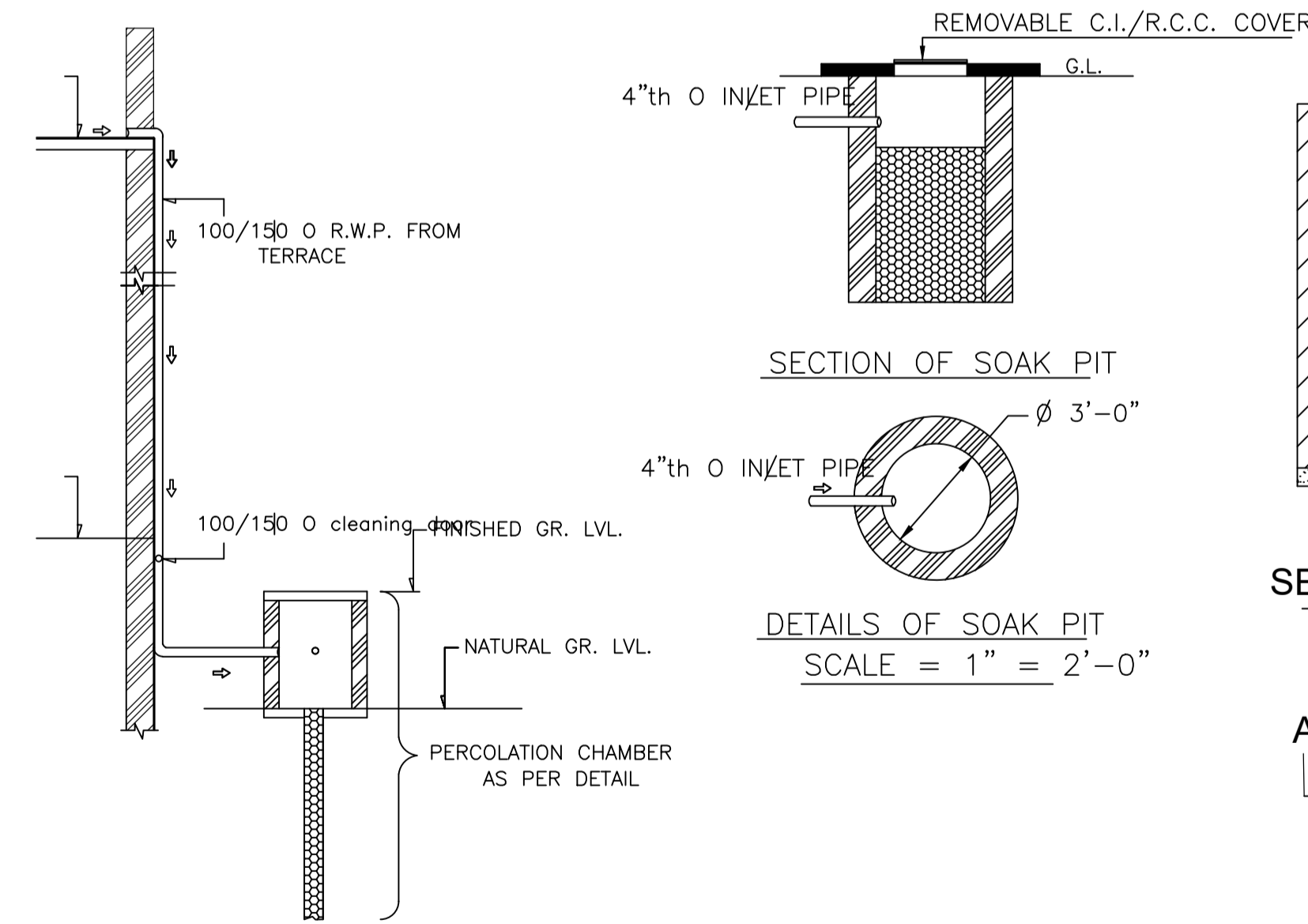

ROOF TOP RAIN WATER COLLECTION SYSTEM  
SCALE = 1" = 4'-0"

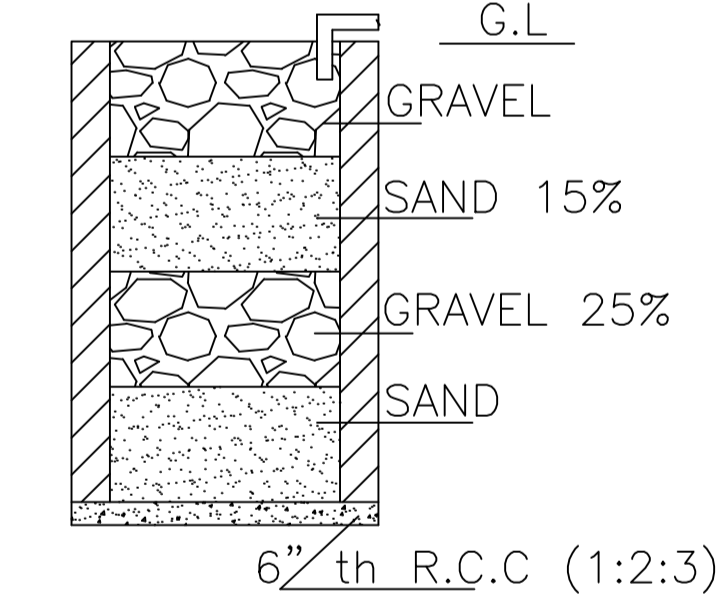

SECTION ON A - B

DETAILS DRAWING OF  
RAIN WATER HARVESTING  
SCALE:- 1"=2'-0"

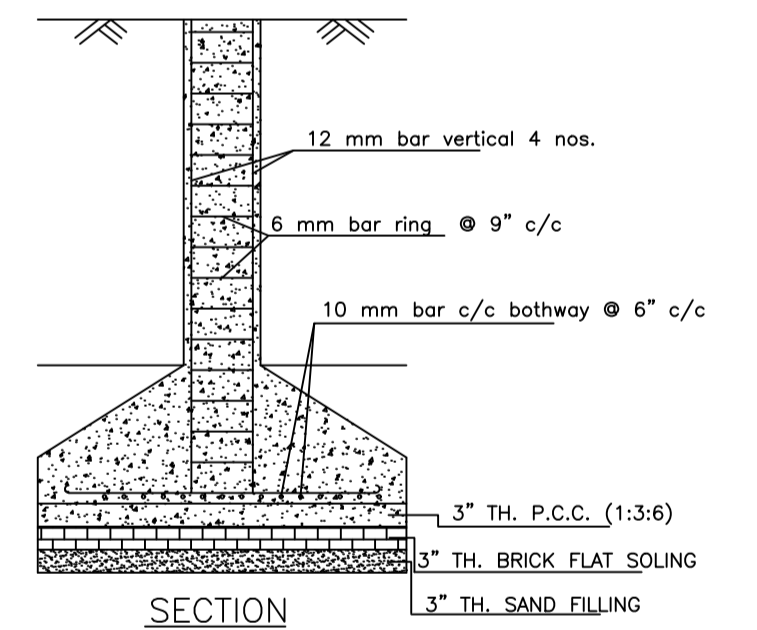

SECTION

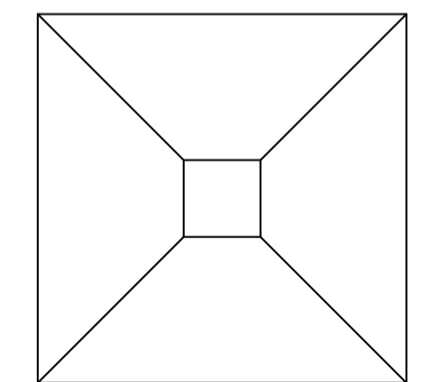

PLAN

DETAILS OF COLUMN FOUNDATION  
SCALE - 1" = 2'-0"

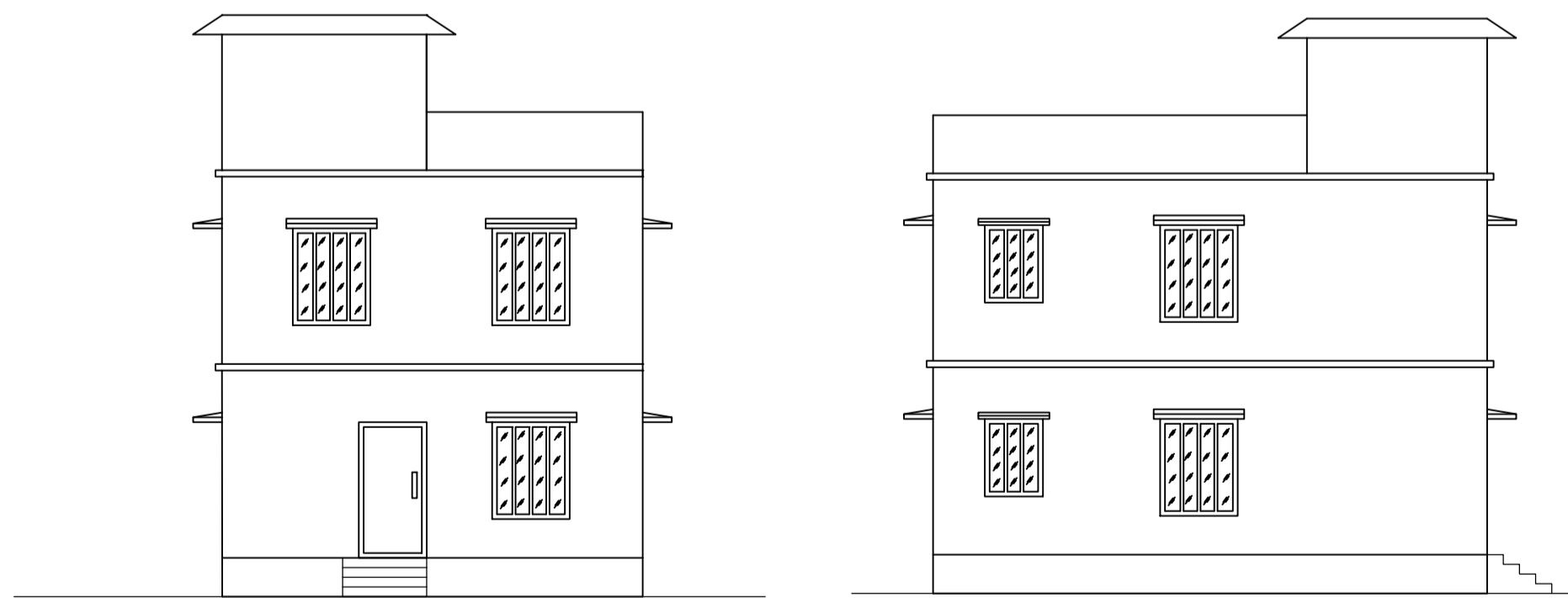

FRONT ELEVATION  
SCALE - 1" = 8'-0"

LEFT SIDE ELEVATION  
SCALE - 1" = 8'-0"

LTP NAME AND SIGNATURE	STRUCTURAL ENG'S NAME AND SIGNATURE	BUILDER NAME AND SIGNATURE	DIGITAL SIGNATURE
RAM PRATAP SINGH MADA/ARC/0024/2019			