

FRONT ELEVATION

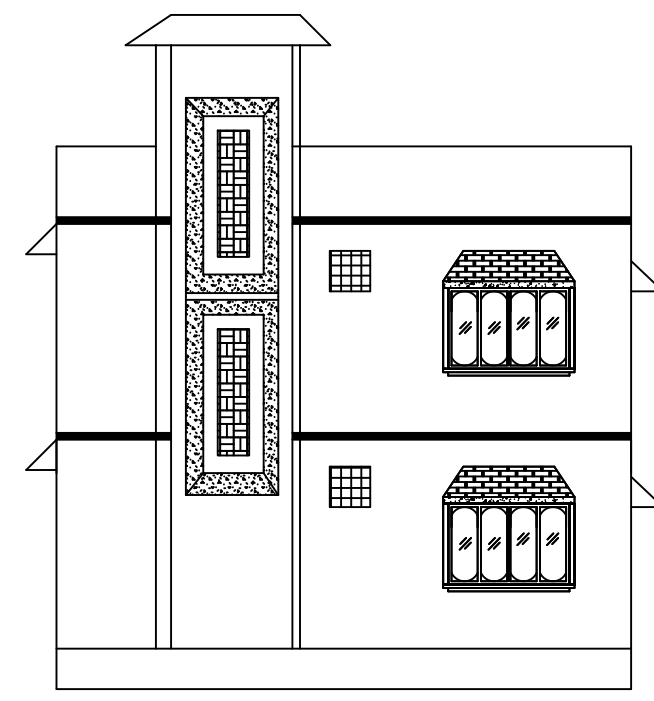

RIGHT SIDE ELEVATION

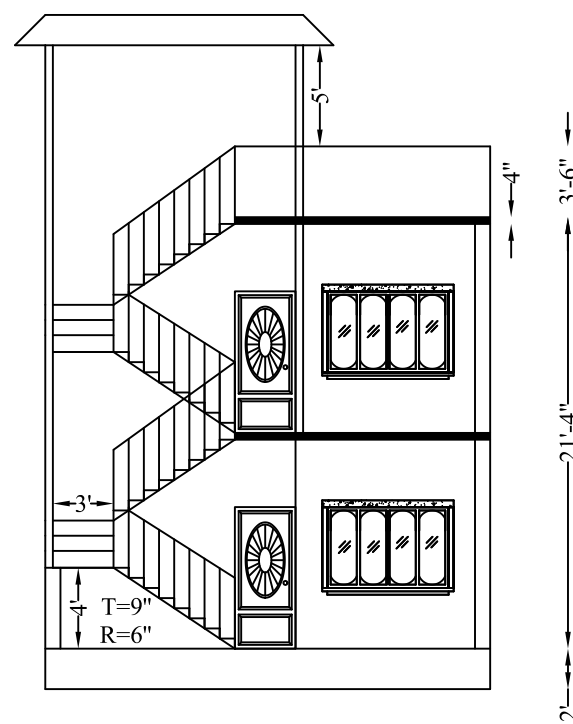

SECTION ON XX

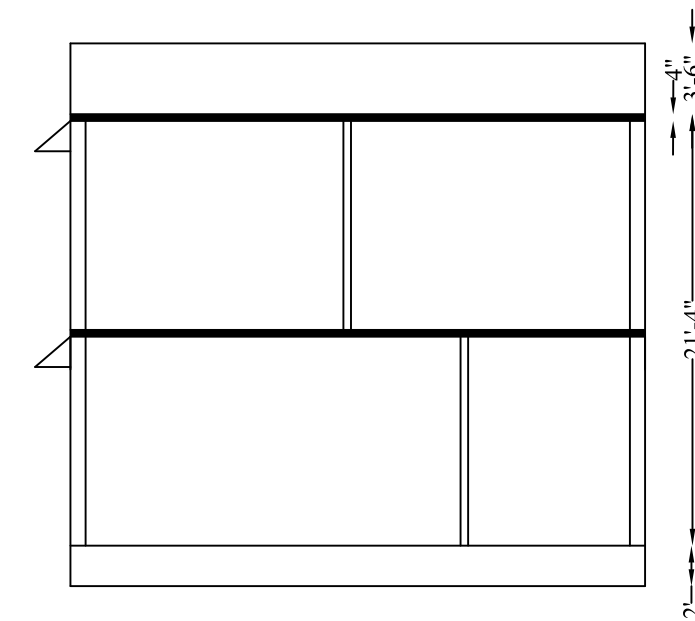

SECTION ON YY

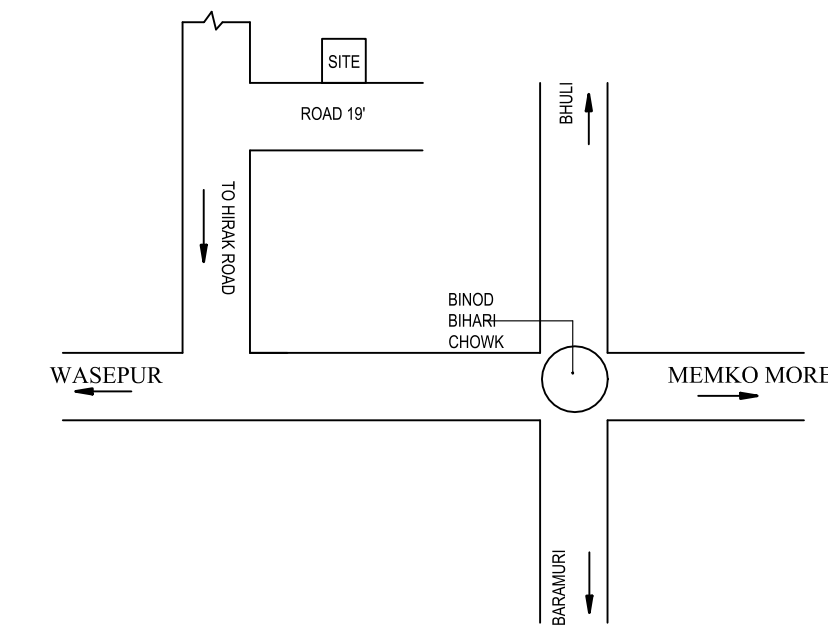

LOCATION PLAN

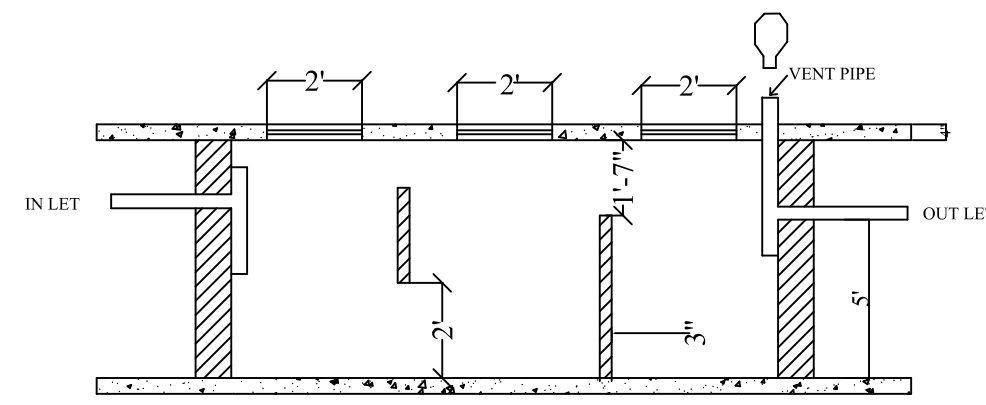

SECTION ON X-X

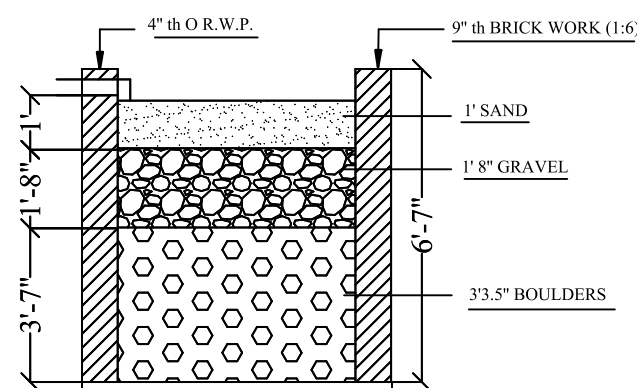

WATER HARVESTING

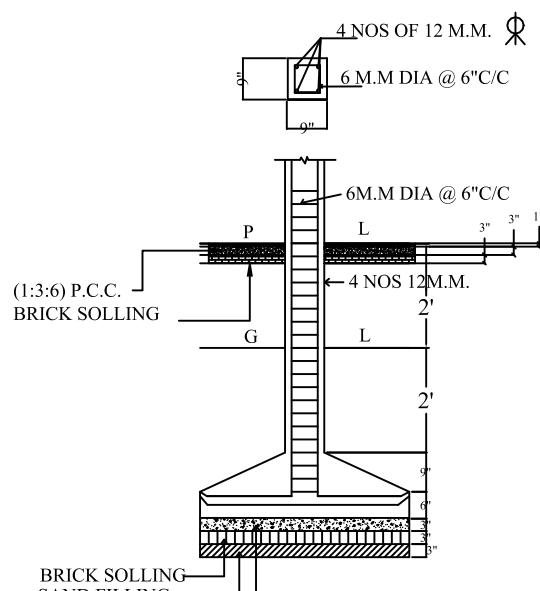

DETAILS OF COLUMN FOOTING

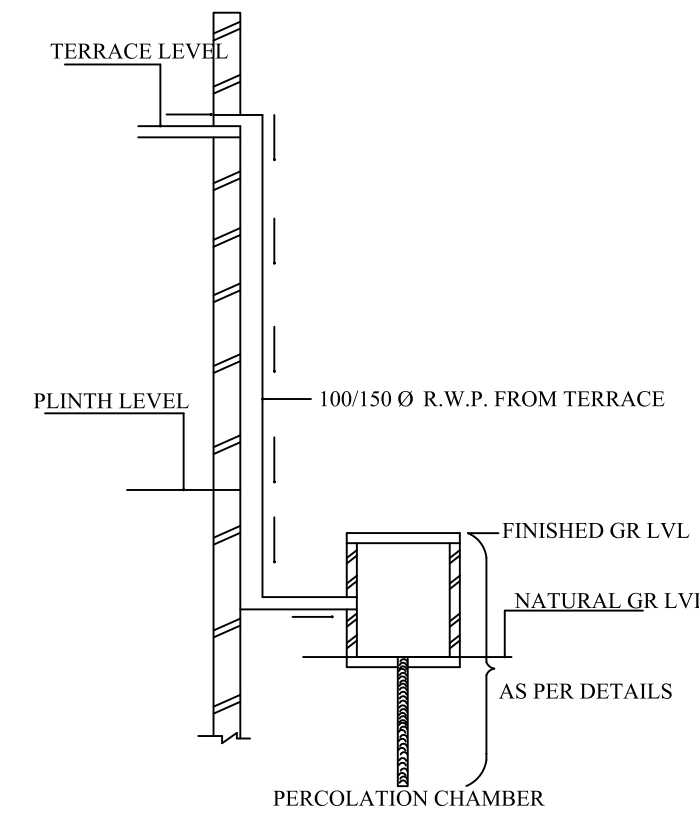

ROOF TOP RAIN WATER COLLECTION SYSTEM

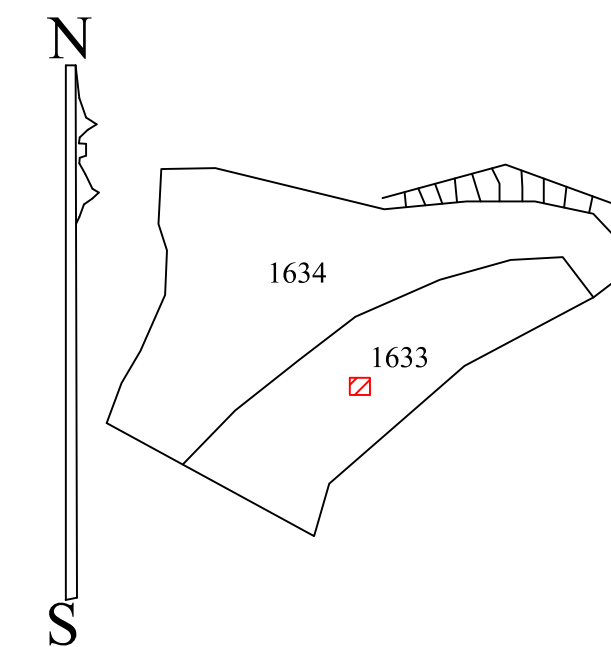

KEY PLAN
1"=330'

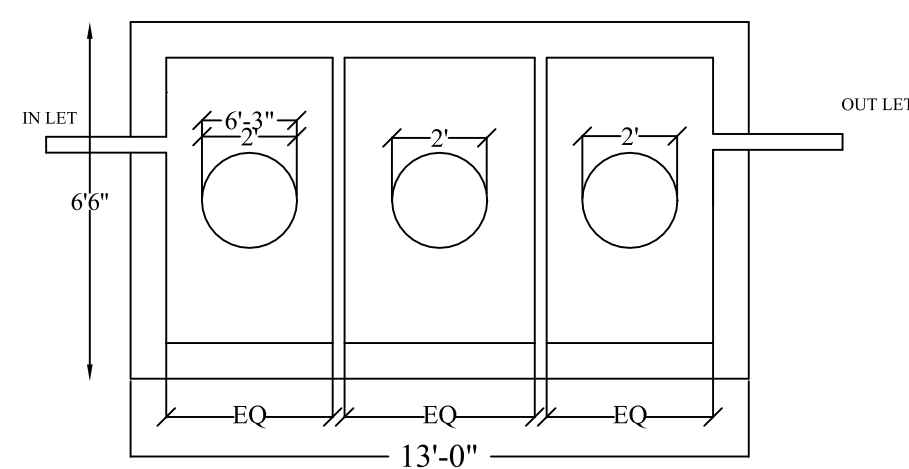

SEPTIC TANK

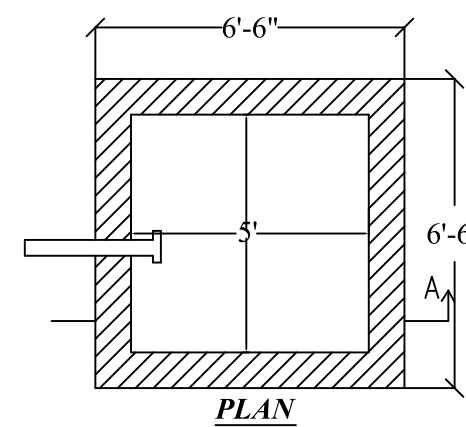

PLAN

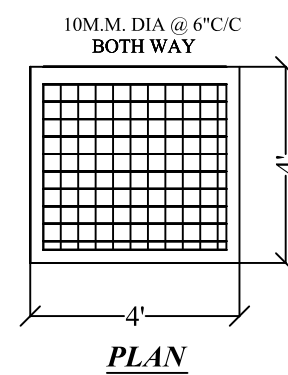

PLAN

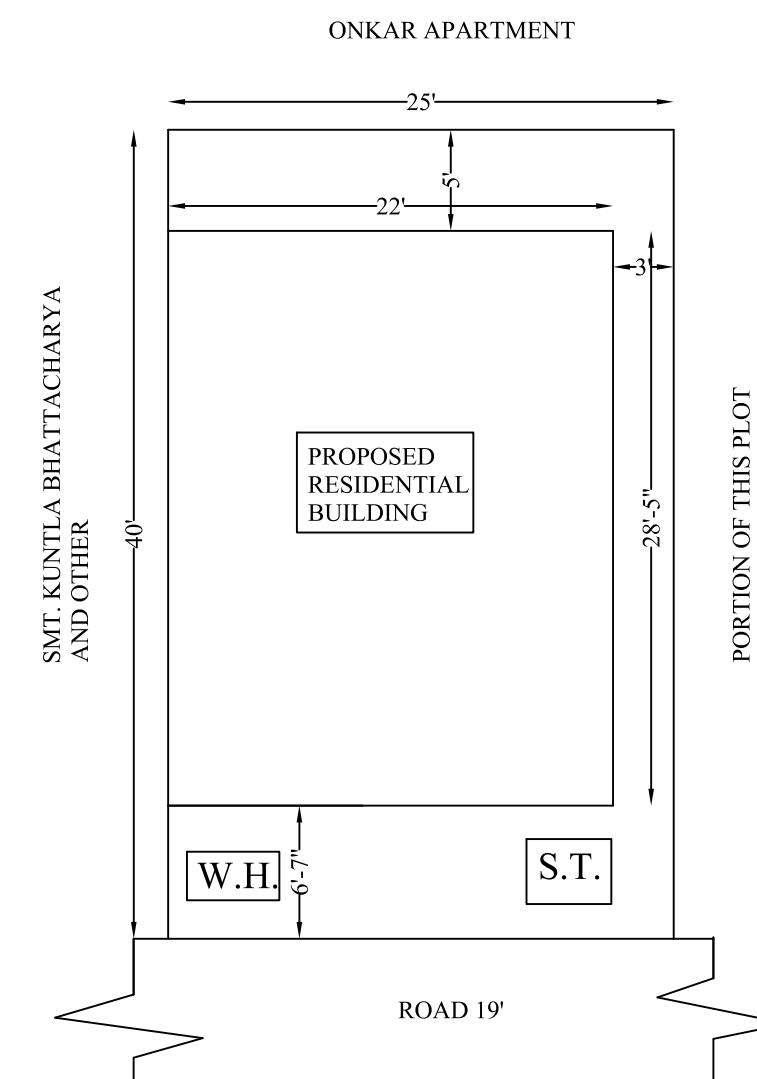

SITE PLAN
1"=8'

ALL DIMENTION ARE IN INTCH/FT.
SCALE-1"=8'

BRIEF SPECIFICATION

FOUNDATION :- R,C,C, (1:1.5:3) Column footing foundation.
PLINTH :- 12"th R.C.C. (1:1.5:3) all round on plinth level
FLOORING :- 1.5"th I.P.S flooring over 3"th P.C.C. (1:3:6)
SUPER STRUCTURE :- First class brick work in cement mortar (1:6).
SLAB,BEAM & LINTEL :- All R.C.C. work (1:1.5:3).
WOOD WORK :- All door & window frames are of sal wood and shutter. 12m,m thick
PLASTERING :- 6.m,m thick cement plaster (1:6) in both side.

SCHEDULE

D1 - 2'6" X 7'0"	W - 6'0" X 4'0"
D - 3'6" X 7'0"	W1 - 4'0" X 4'0"
	V - 2'0" X 2'0"

DETAILS OF AREA

AVAI LAND AREA(AS PER DEED) ---- 1000.00 sqft
 AVAI LAND AREA1000.00 sqft
 PLINTH AREA625.16 sqft
 FIRST FLOOR AREA625.16 sqft
 TOTAL BUILTUP AREA 1250.32 sqft
 % PLINTH AREA62.51 %
 F.A.R.....1.25

TITLE OF DRAWING

PROPOSED RESIDENTIAL BUILDING PLAN OF SMT. GURIYA DEVI W/O SRI SANTOSH KUMAR SINGH, MOUZA IN NAWADIIH NO. 02, OLD KHATA NO. 74 , NEW KHATA NO. 64, OLD PLOT NO. 1454, NEW PLOT NO.1633. AREA- 2.30 DECIMAL . LOT NO. 10 (DIST-DHANBAD)

SIG. OF OWNER

SIG. OF ENGINEER

(Er. SANTOSH)
 HI-TECH ASSOCIATES
 22,UNION-CLUB MARKET
 LUBY CIRCULAR ROAD
 DHANBAD

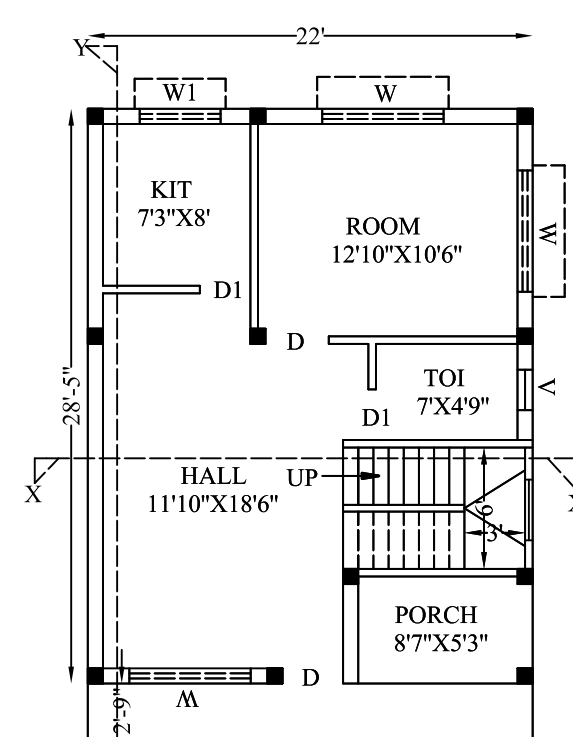

GROUND FLOOR PLAN

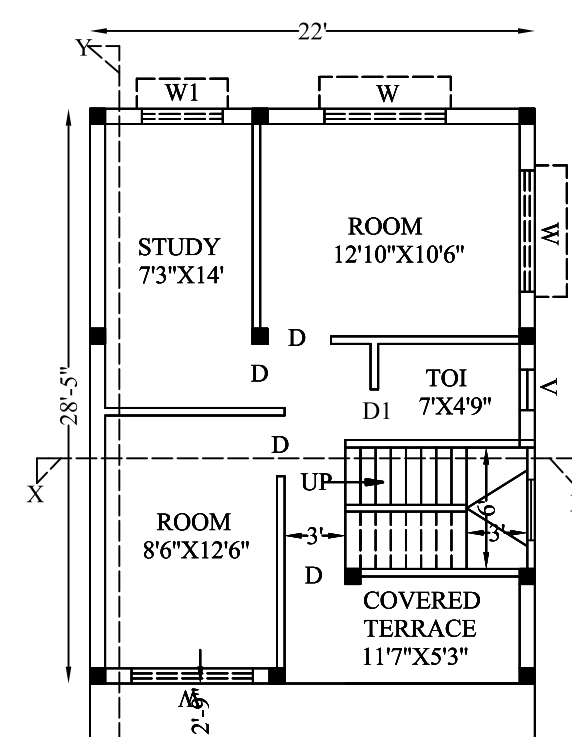

1ST FLOOR PLAN

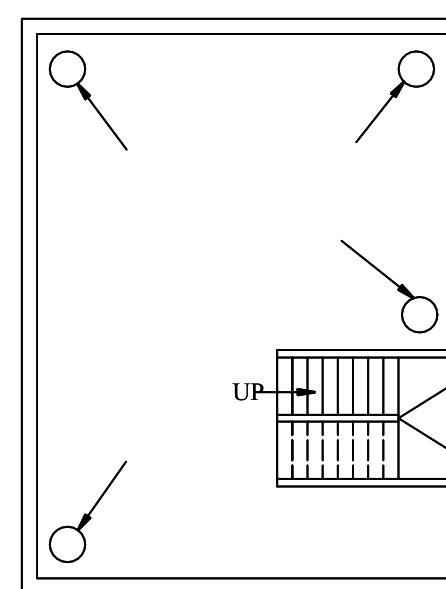

TERRACE FLOOR