

FRONT ELEVATION

RIGHT SIDE ELEVATION

KEY PLAN
1"=330'

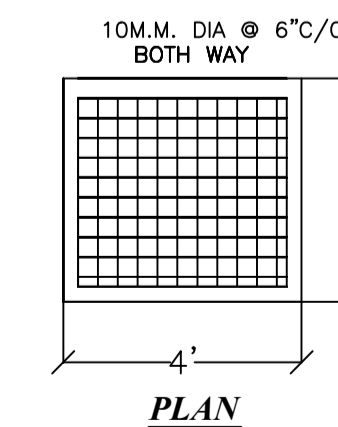
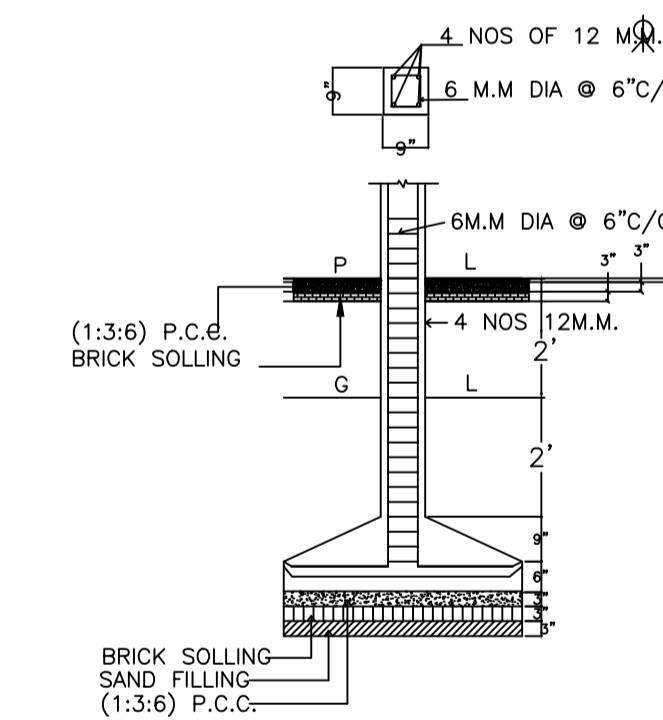
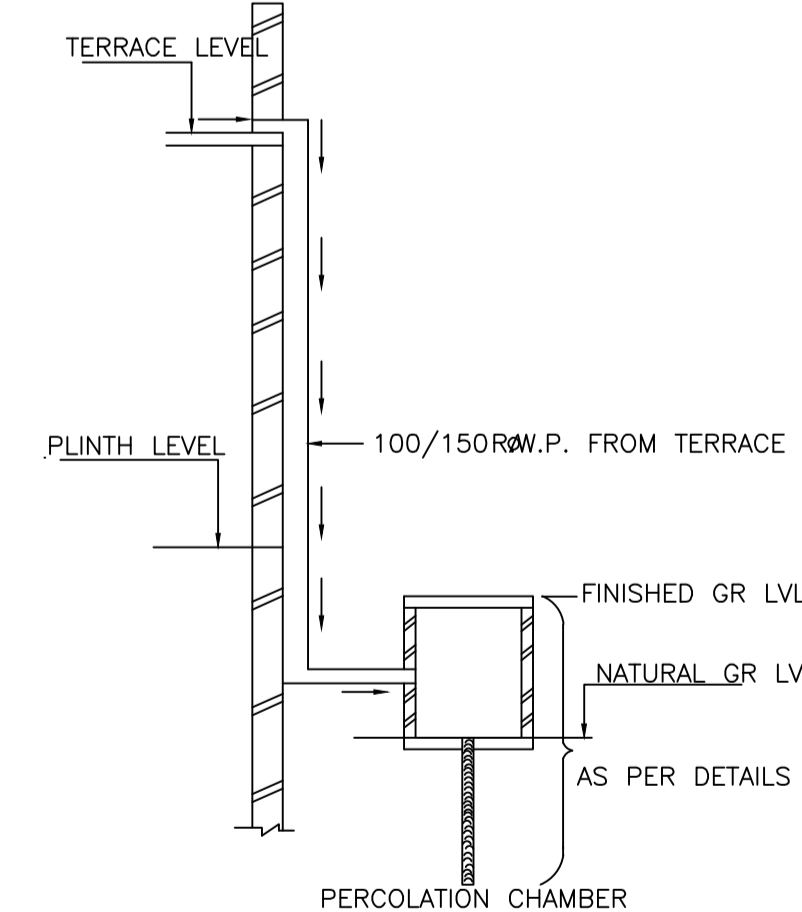
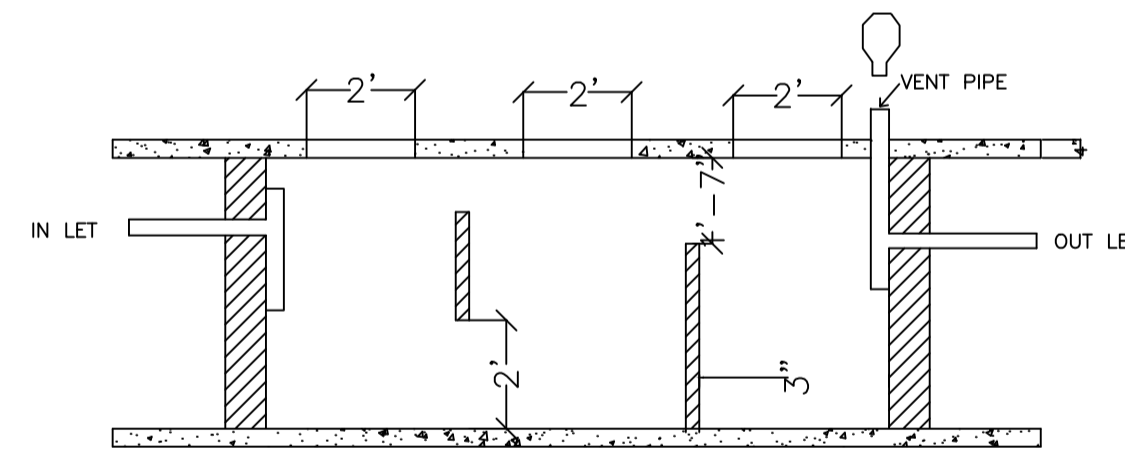
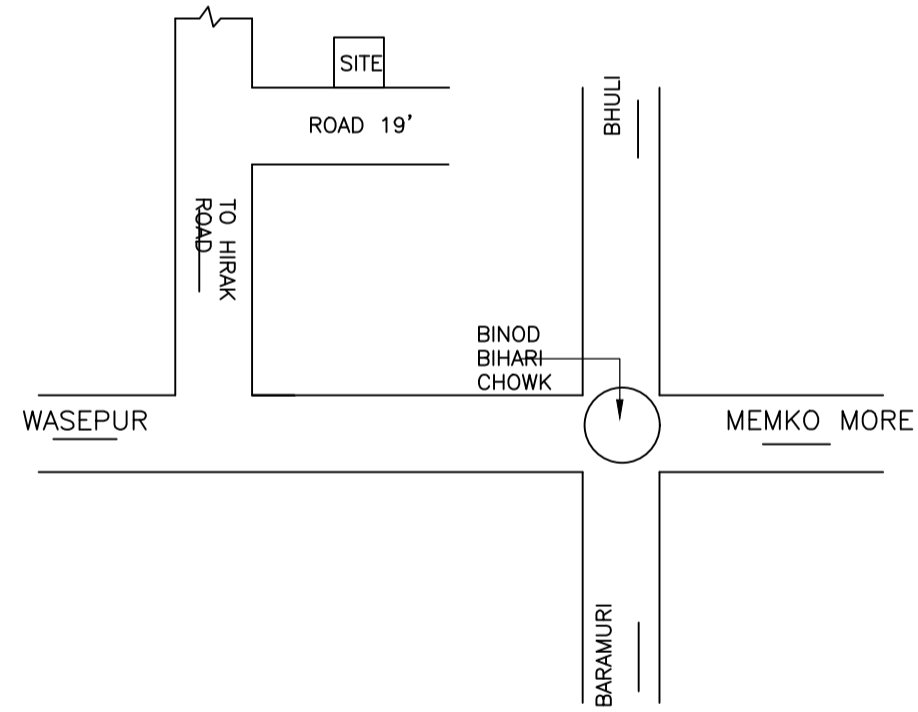
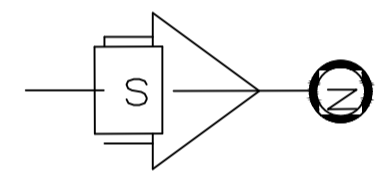

SCHEDULE OF DOOR:

BUILDING NAME	NAME	LENGTH	HEIGHT	NOS
A (A)	D	0.76	2.10	03
A (A)	D	0.91	2.10	03
A (A)	D	0.95	2.10	02
A (A)	D	0.97	2.10	01
A (A)	ARCH	1.27	2.10	02
A (A)	ARCH	2.40	2.10	01
A (A)	ARCH	3.54	2.10	01

SCHEDULE OF WINDOW/VENTILATION:

BUILDING NAME	NAME	LENGTH	HEIGHT	NOS
A (A)	W	0.61	1.20	02
A (A)	W	0.91	1.20	02
A (A)	W	1.22	1.20	02
A (A)	W	1.83	1.20	06

Building :A (A)

Floor Name	Total Built Up Area (Sq.mt.)	Proposed FAR Area (Sq.mt.) Res.	Total FAR Area (Sq.mt.)	Total Consumed Additional FAR Area (Sq.mt.)	Tnmt (No.)
Ground Floor	58.08	58.08	58.08	58.08	01
First Floor	58.08	58.08	58.08	58.08	00
Terrace Floor	0.00	0.00	0.00	0.00	00
Total	116.16	116.16	116.16	116.16	01
Total Number of Same Buildings	1				
Total	116.16	116.16	116.16	116.16	01

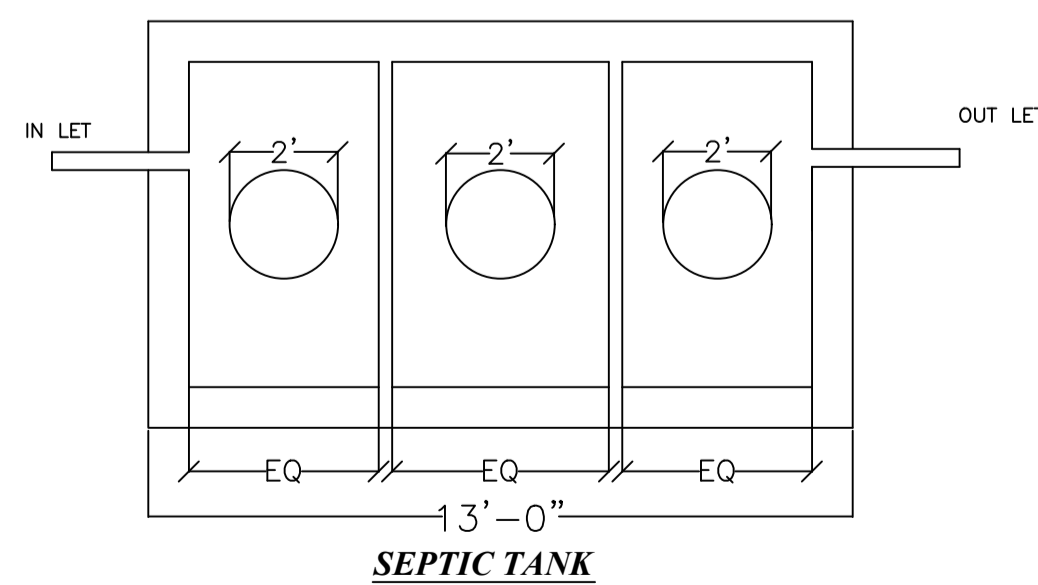

Proposal Basic Information

Proposal File No.	MADA/BP/0369/2021
Owner Name	SMT. GURIYA DEVI
Khata No	OLD-74, NEW-64
Plot No	OLD- 1454 NEW- 1633
Village Name	Nawadh
Use	Residential
SubUse	Bungalow/ Dwelling / Non Apartment

AREA STATEMENT MINERAL AREA DEVELOPMENT AUTHORITY	VERSION NO.: 1.0.62	VERSION DATE: 16/10/2020
PROJECT DETAIL:	Plot Use: Residential	
Region: JHARKHAND URBAN LOCAL BODIES	Plot SubUse: Bungalow/ Dwelling / Non Apartment	
District: DHANBAD	PlotNearbyReligiousStructure: NA	
Authority: MINERAL AREA DEVELOPMENT AUTHORITY	Plot/SubPlot No: OLD- 1454 NEW- 1633	
Inward No: MADA/BP/0369/2021	North: Plot No. - PORTION OF THIS PLOT	
Application Type: General Proposal	South: Plot No. - SMT. KUNTLA BHATTACHARYA & OTHER	
Project Type: Building Permission	East: Road Width - 5.79	
Nature of Development: New	West: Plot No. - ONKAR APARTMENT	
Location of Development Area: Old Area		
AREA DETAILS:		SQ.MT.
AREA OF PLOT (Minimum)	(A)	92.75
NET AREA OF PLOT(Gross Plot Area - Deduction from Gross Plot area)	(A-Deductions)	92.75
Deduction for Balance Plot Area(from Gross Plot Area)		
Common Plot		5.81
Total		5.81
BALANCE AREA OF PLOT(Net Plot Area - Recreational/Amenity space)	(A-Deductions)	86.94
PLOT AREA FOR COVERAGE(Net Plot Area)	(A-Deductions)	92.75
Plot Area for FAR (Net Plot Area + Road Widening Area)	(A-Deductions)	92.75
COVERAGE CHECK		
Permissible Coverage area (70.00 %)		64.92
Proposed Coverage Area (62.62 %)		58.08
Total Prop. Coverage Area (62.62 %)		58.08
Balance coverage area (7.37 %)		6.64
FAR CHECK		
Perm. FAR Area (1.80)		166.95
Total Perm. FAR area		166.95
Residential FAR		116.16
Proposed FAR Area		116.16
Total Proposed FAR Area		116.16
Consumed FAR (Factor)		1.25
Balance FAR Area		50.79
BUILT UP AREA CHECK		
Total Proposed BuiltUp Area		116.16
ARCHITECT (Regd)	SANTOSH	
ENGINEER (Regd)		
SUPERVISOR (Regd)		
OWNER (Regd)	SMT. GURIYA DEVI	
DEVELOPMENT AUTHORITY	LOCAL BODY	

COLOR INDEX

PLOT BOUNDARY	Black
ABUTTING ROAD	Green
PROPOSED CONSTRUCTION	Red
COMMON PLOT	Yellow
ROAD WIDENING AREA	Blue
EXISTING (To be retained)	Light Blue
EXISTING (To be demolished)	Dark Blue

Buildingwise Floor FAR Details

Floor Name	Building Name		Total	
	Proposed Built Up Area (Sq.mt.)	Proposed FAR Area (Sq.mt.)	Total Proposed Built Up Area (Sq.mt.)	Total FAR Area (Sq.mt.)
Ground Floor	58.08	58.08	58.08	58.08
First Floor	58.08	58.08	58.08	58.08
Terrace Floor	0.00	0.00	0.00	0.00
Total	116.16	116.16	116.16	116.16

Building USE/SUBUSE Details

Building Name	Building Use	Building SubUse	Building Structure
A (A)	Residential	Residential Bldg/Apartment	Non-Highrise

FAR & Tenement Details (Table 4c-1)

Building	No. of Same Bldg	Total Built Up Area (Sq.mt.)	Proposed FAR Area (Sq.mt.) Res.	Total FAR Area (Sq.mt.)	Total Consumed Additional FAR Area (Sq.mt.)	Tnmt (No.)
A (A)	1	116.16	116.16	116.16	116.16	01
Grand Total	1	116.16	116.16	116.16	116.16	01

UnitBUA Table for Building :A (A)

FLOOR	Name	UnitBUA Type	UnitBUA Area	Carpet Area	No. of Rooms	No. of Tenement
GROUND FLOOR PLAN	SPLIT A	FLAT	116.16	116.11	5	1
FIRST FLOOR PLAN	SPLIT A	FLAT	0.00	0.00	6	0
Total	-	-	116.16	116.11	11	1

LTP NAME AND SIGNATURE	STRUCTURAL ENG'S NAME AND SIGNATURE	BUILDER NAME AND SIGNATURE	DIGITAL SIGNATURE
SANTOSH MADA/ENG/0022/2019			

Proposal Basic Information	
Proposal File No.	MADA/BP/0369/2021
Owner Name	SMT. GURIYA DEVI
Khata No	OLD-74, NEW-64
Plot No	OLD- 1454 NEW- 1633
Village Name	Nawadhi
Use	Residential
SubUse	Bungalow/ Dwelling / Non Apartment

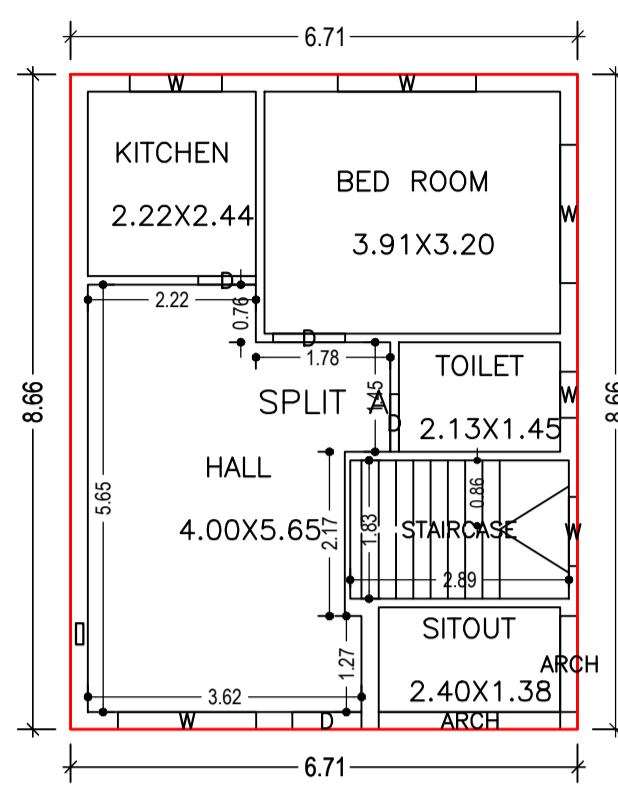

GROUND FLOOR PLAN
(Proposed)
(SCALE 1:100)

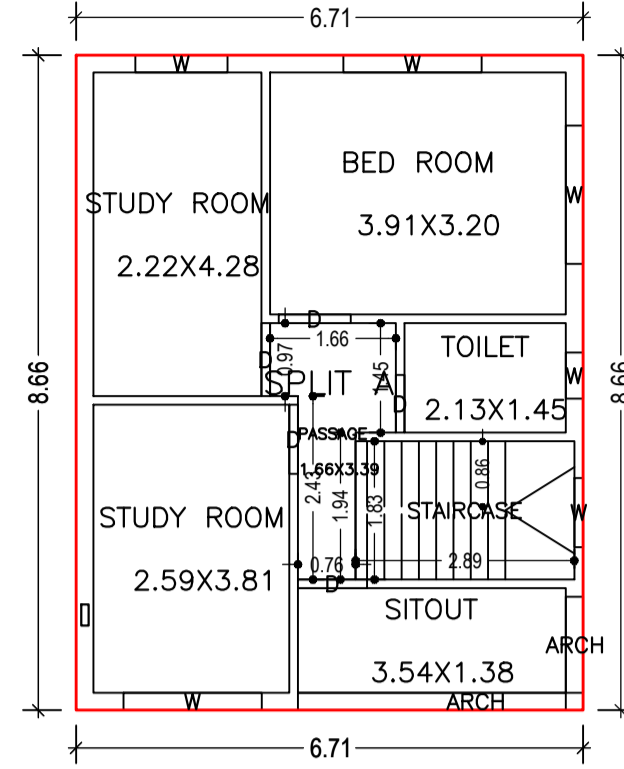

FIRST FLOOR PLAN
(Proposed)
(SCALE 1:100)

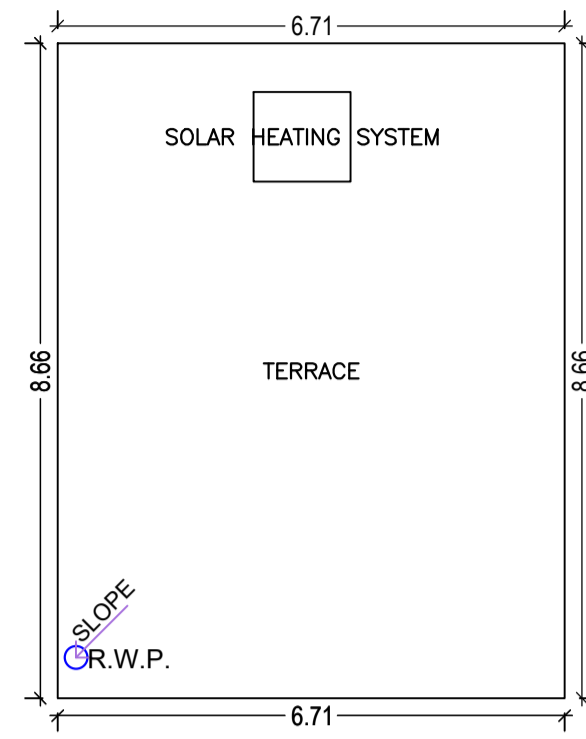

TERRACE FLOOR PLAN
(SCALE 1:100)

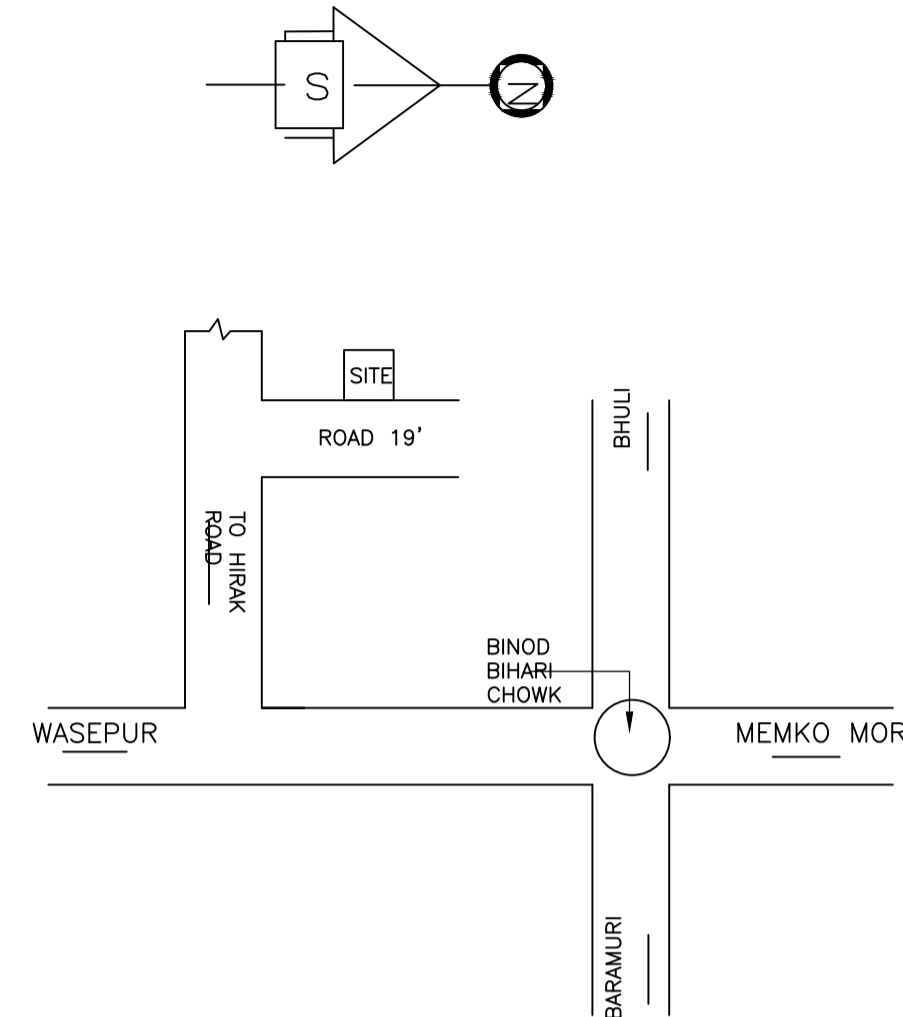

LOCATION PLAN

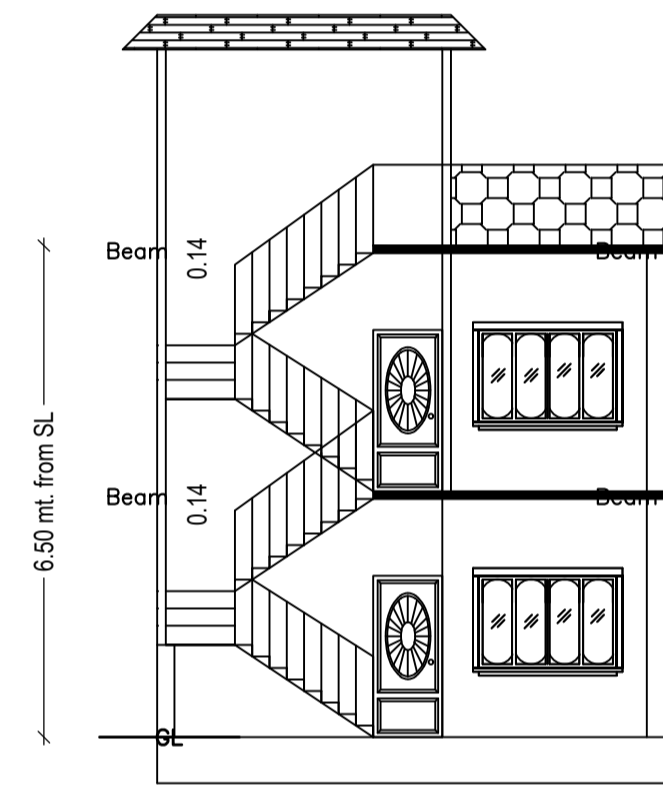

SECTION ON XX

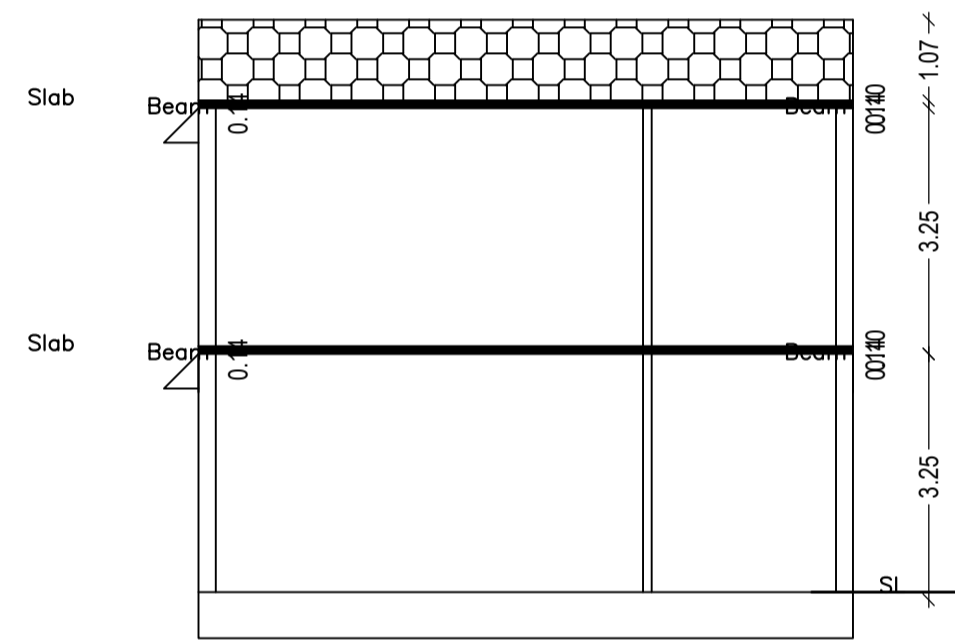

SECTION ON YY

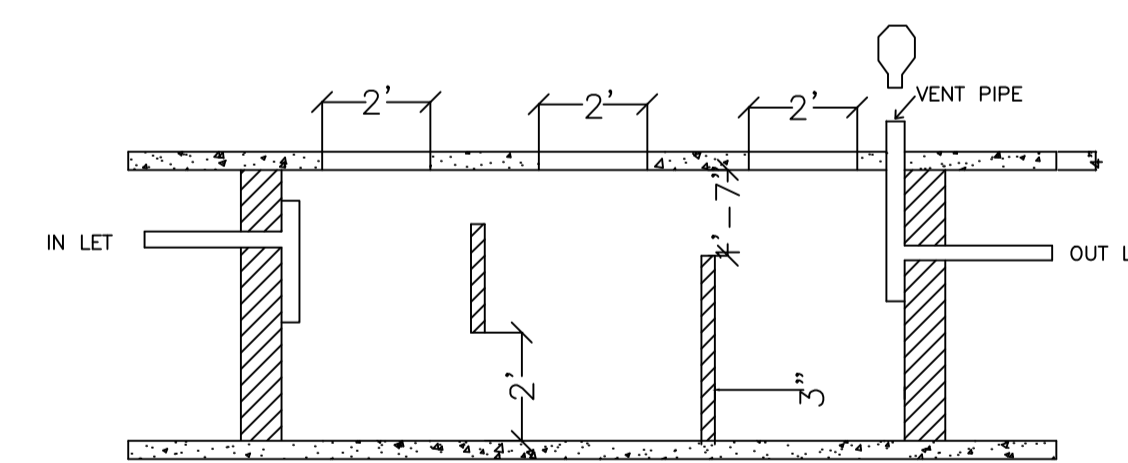

SECTION ON-X-X

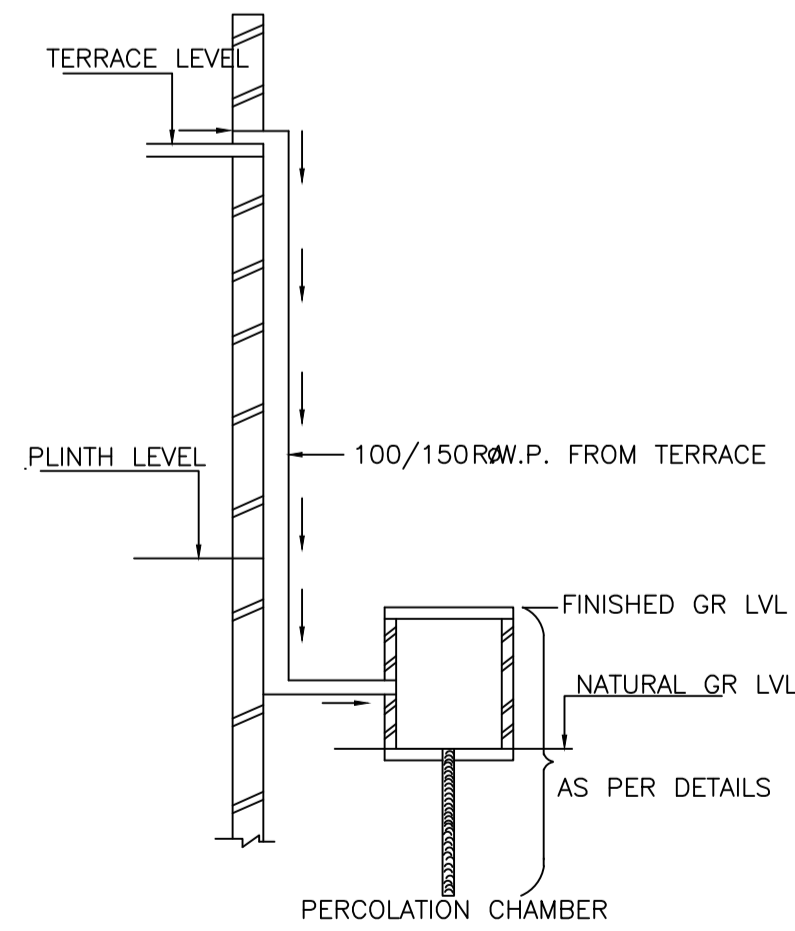

ROOF TOP RAIN WATER
COLLECTION SYSTEM

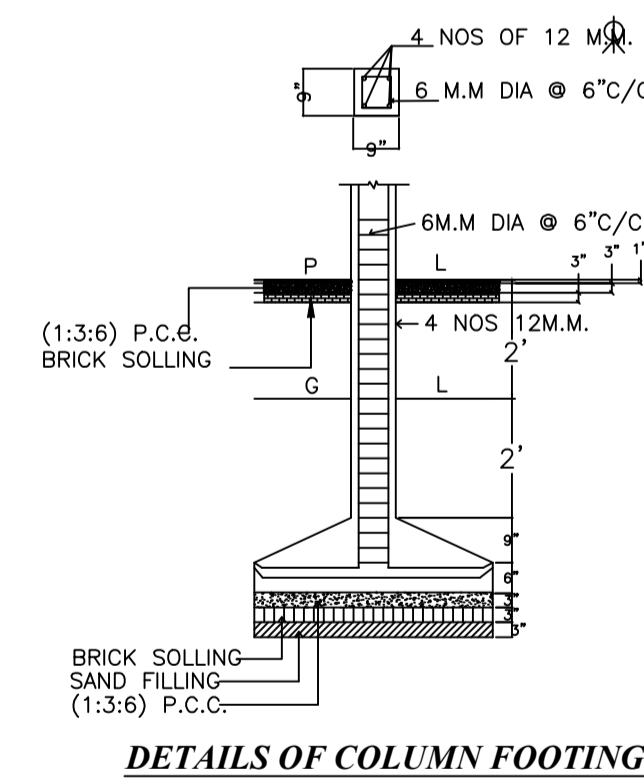

DETAILS OF COLUMN FOOTING

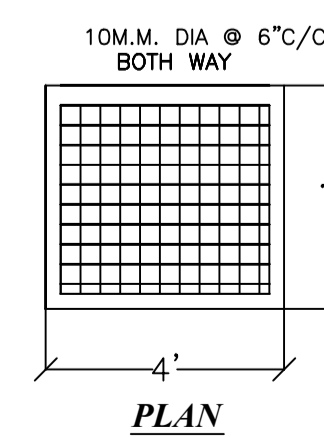

PLAN

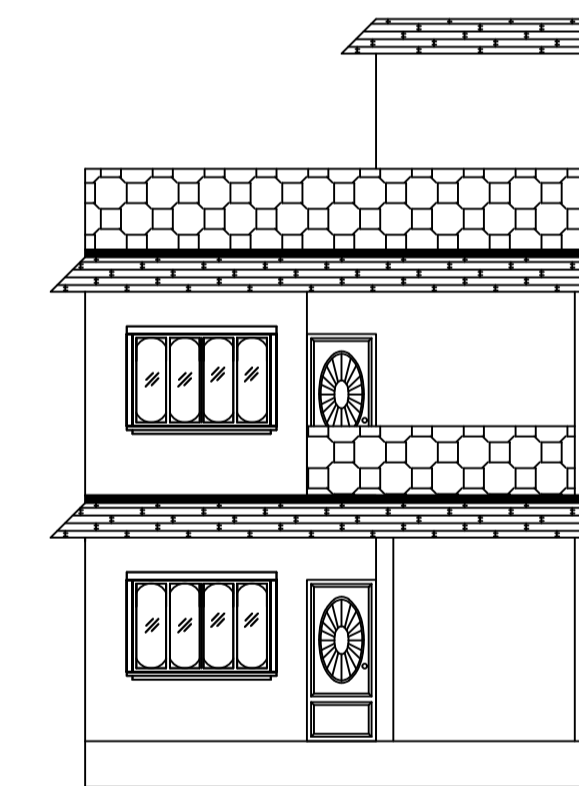

FRONT ELEVATION

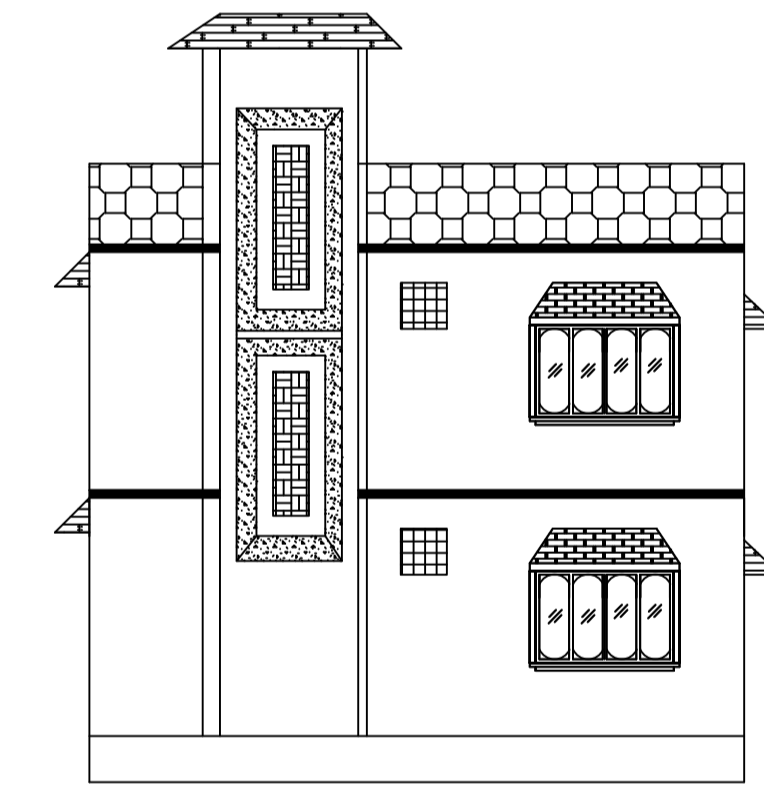

RIGHT SIDE ELEVATION

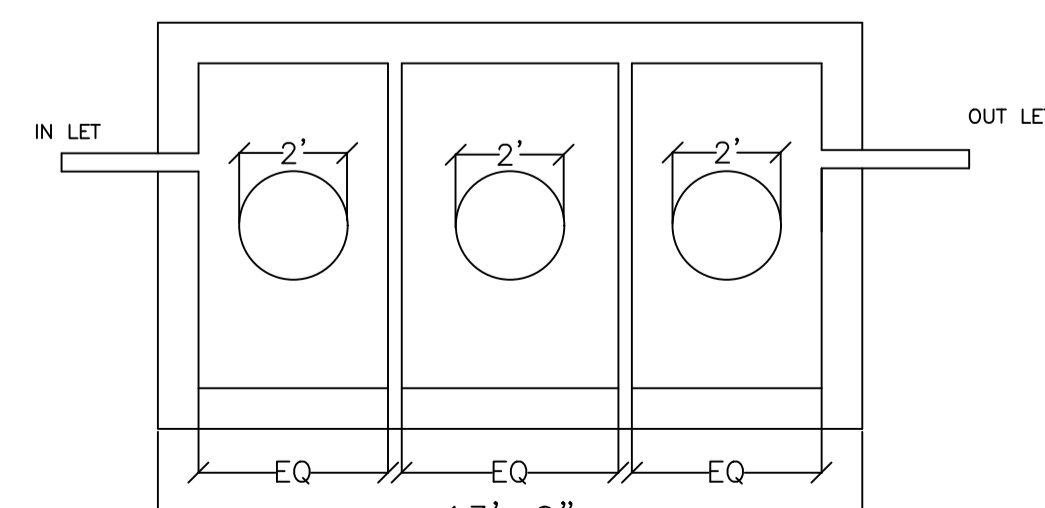

SEPTIC TANK

LTP NAME AND SIGNATURE	STRUCTURAL ENG'S NAME AND SIGNATURE	BUILDER NAME AND SIGNATURE	DIGITAL SIGNATURE
SANTOSH MADA/ENG/0022/2019			