

Proposal Basic Information

Proposal File No.	MADA/BP/0360/2021
Owner Name	SMT. SARITA DEVI
Khata No	OLD-74, NEW-64
Plot No	OLD- 1454 NEW- 1633
Village Name	Nawadih
Use	Residential
SubUse	Bungalow/ Dwelling / Non Apartment

AREA STATEMENT MINERAL AUTHORITY	VERSION NO.: 1.0.62	SQ.MT.
PROJECT DETAIL:	VERSION DATE: 16/10/2020	
Region: JHARKHAND URBAN LOCAL BODIES	Plot Use: Residential	
District: DHANBAD	Plot SubUse: Bungalow/ Dwelling / Non Apartment	
Authority: MINERAL AREA DEVELOPMENT AUTHORITY	PlotNearby/ReligiousStructure: NA	
Inward No: MADA/BP/0360/2021	Plot/SubPlot No: OLD- 1454 NEW- 1633	
Application Type: General Proposal	North: Plot No. - PORTION OF THIS PLOT	
Project Type: Building Permission	South: Plot No. - SRI RAJ KUMAR VISHAWARMA	
Nature of Development: New	East: Road Width - 5.79	
Location of Development Area: Old Area	West: Plot No. - ONKAR APARTMENT	
AREA DETAILS:		
AREA OF PLOT (Minimum)	(A)	92.75
NET AREA OF PLOT(Gross Plot Area - Deduction from Gross Plot area)	(A-Deductions)	92.75
Deduction for Balance Plot Area(from Gross Plot Area)		
Common Plot		7.65
Total		7.65
BALANCE AREA OF PLOT(Net Plot Area - Recreational/Amenity space)	(A-Deductions)	85.10
PLOT AREA FOR COVERAGE(Net Plot Area)	(A-Deductions)	92.75
Plot Area for FAR (Net Plot Area + RoadWidening Area)	(A-Deductions)	92.75
COVERAGE CHECK		
Permissible Coverage area ( 70.00 % )		64.92
Proposed Coverage Area ( 62.62 % )		58.08
Total Prop. Coverage Area ( 62.62 % )		58.08
Balance coverage area ( 7.37 % )		6.84
FAR CHECK		
Perm. FAR Area ( 1.80 )		166.95
Total Perm. FAR area		166.95
Residential FAR		116.16
Proposed FAR Area		116.16
Total Proposed FAR Area		116.16
Consumed FAR (Factor)		1.25
Balance FAR Area		50.79
BUILT UP AREA CHECK		
Total Proposed BuiltUp Area		116.16
ARCHITECT (Regd)	SANTOSH	
ENGINEER (Regd)		
SUPERVISOR (Regd)		
OWNER (Regd)	SMT. SARITA DEVI	
DEVELOPMENT AUTHORITY		LOCAL BODY

COLOR INDEX

PLOT BOUNDARY	Black
ABUTTING ROAD	Green
PROPOSED CONSTRUCTION	Red
COMMON PLOT	Yellow
ROAD WIDENING AREA	Blue
EXISTING (To be retained)	Light Blue
EXISTING (To be demolished)	Dark Blue

Buildingwise Floor FAR Details

Floor Name	Building Name A (A)		Total	
	Proposed Built Up Area (Sq.mt.)	Proposed FAR Area (Sq.mt.)	Total Proposed Built Up Area (Sq.mt.)	Total FAR Area (Sq.mt.)
Ground Floor	58.08	58.08	58.08	58.08
First Floor	58.08	58.08	58.08	58.08
Terrace Floor	0.00	0.00	0.00	0.00
Total :	116.16	116.16	116.16	116.16

Building USE/SUBUSE Details

Building Name A (A)	Building Use Residential	Building SubUse Residential Bldg/Apartment	Building Structure Non-Highrise

FAR & Tenement Details (Table 4c-1)

Building	No. of Same Bldg	Total Built Up Area (Sq.mt.)	Proposed FAR Area (Sq.mt.) Resi.	Total FAR Area (Sq.mt.)	Total Consumed Additional FAR Area (Sq.mt.)	Trmnt (No.)
A (A)	1	116.16	116.16	116.16	116.16	01
Grand Total :	1	116.16	116.16	116.16	116.16	01

UnitBUA Table for Building :A (A)

FLOOR	Name	UnitBUA Type	UnitBUA Area	Carpet Area	No. of Rooms	No. of Tenement
GROUND FLOOR PLAN	SPLIT A	FLAT	116.16	116.03	5	1
FIRST FLOOR PLAN	SPLIT A	FLAT	0.00	0.00	6	0
Total:	-	-	116.16	116.03	11	1

SCHEDULE OF DOOR:

BUILDING NAME	NAME	LENGTH	HEIGHT	NOS
A (A)	D	0.76	2.10	03
A (A)	D	0.91	2.10	03
A (A)	D	0.95	2.10	02
A (A)	D	0.97	2.10	01
A (A)	D	1.03	2.10	01

SCHEDULE OF WINDOW/VENTILATION:

BUILDING NAME	NAME	LENGTH	HEIGHT	NOS
A (A)	V	0.61	1.20	02
A (A)	W	1.22	1.20	02
A (A)	W	1.83	1.20	06

Building :A (A)

Floor Name	Total Built Up Area (Sq.mt.)	Proposed FAR Area (Sq.mt.) Resi.	Total FAR Area (Sq.mt.)	Total Consumed Additional FAR Area (Sq.mt.)	Trmnt (No.)
Ground Floor	58.08	58.08	58.08	58.08	01
First Floor	58.08	58.08	58.08	58.08	00
Terrace Floor	0.00	0.00	0.00	0.00	00
Total :	116.16	116.16	116.16	116.16	01
Total Number of Same Buildings :	1				
Total :	116.16	116.16	116.16	116.16	01

LTP NAME AND SIGNATURE	STRUCTURAL ENG'S NAME AND SIGNATURE	BUILDER NAME AND SIGNATURE	DIGITAL SIGNATURE
SANTOSH MADA/ENG/0022/2019			

Proposal Basic Information

Proposal File No.	MADA/BP/0360/2021
Owner Name	SMT. SARITA DEVI
Khata No	OLD-74, NEW-64
Plot No	OLD- 1454 NEW- 1633
Village Name	Nawadh
Use	Residential
SubUse	Bungalow/ Dwelling / Non Apartment

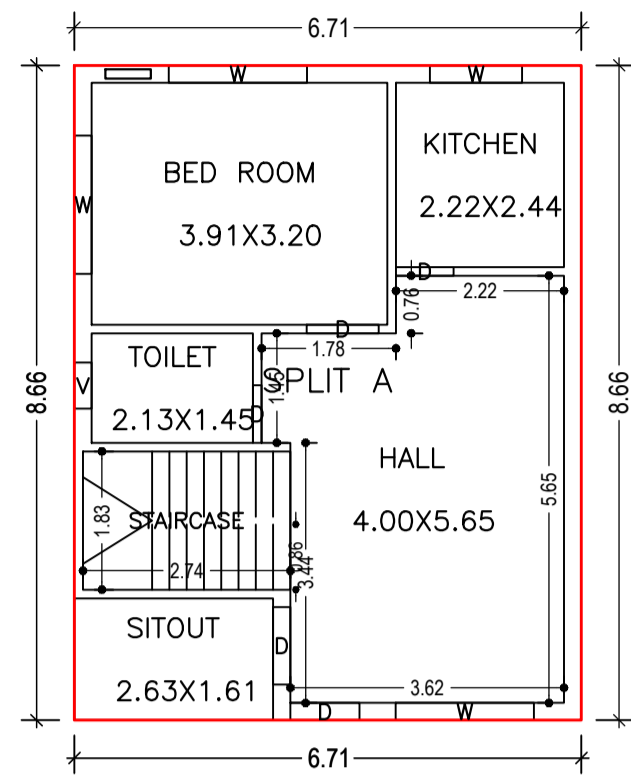

GROUND FLOOR PLAN (Proposed) (SCALE 1:100)

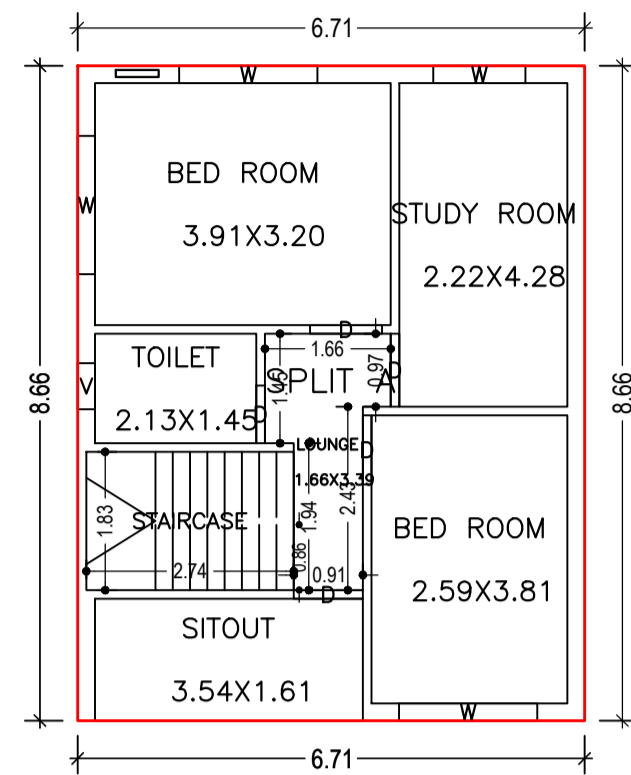

FIRST FLOOR PLAN (Proposed) (SCALE 1:100)

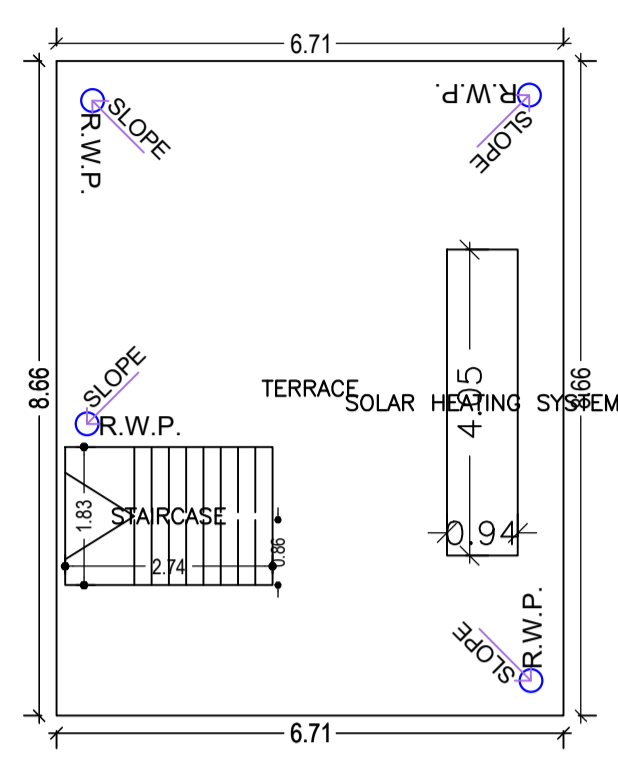

TERRACE FLOOR PLAN (SCALE 1:100)

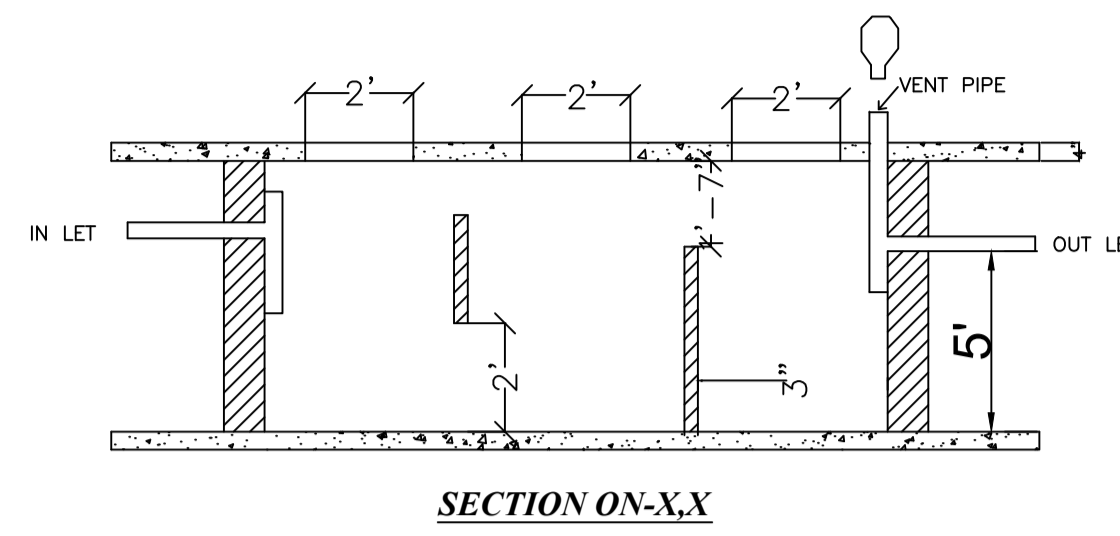

SECTION ON-X,X

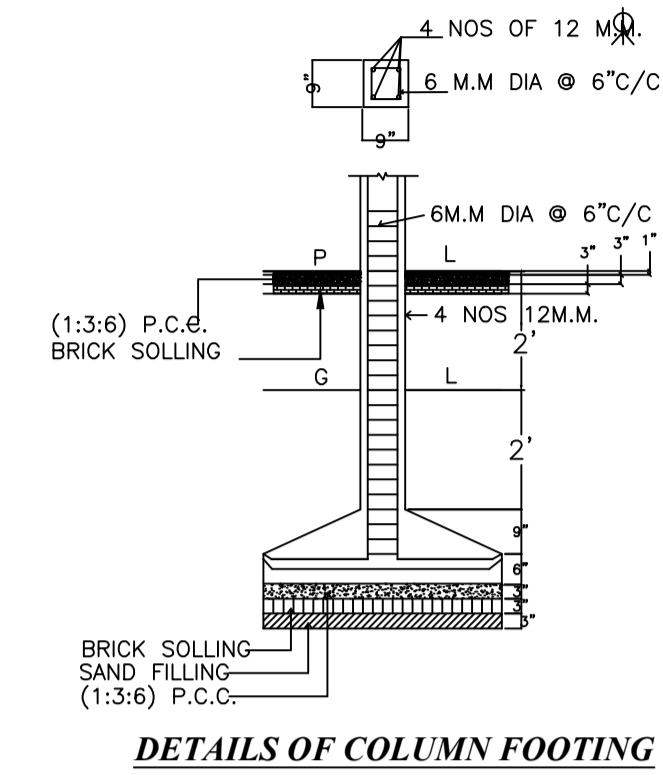

DETAILS OF COLUMN FOOTING

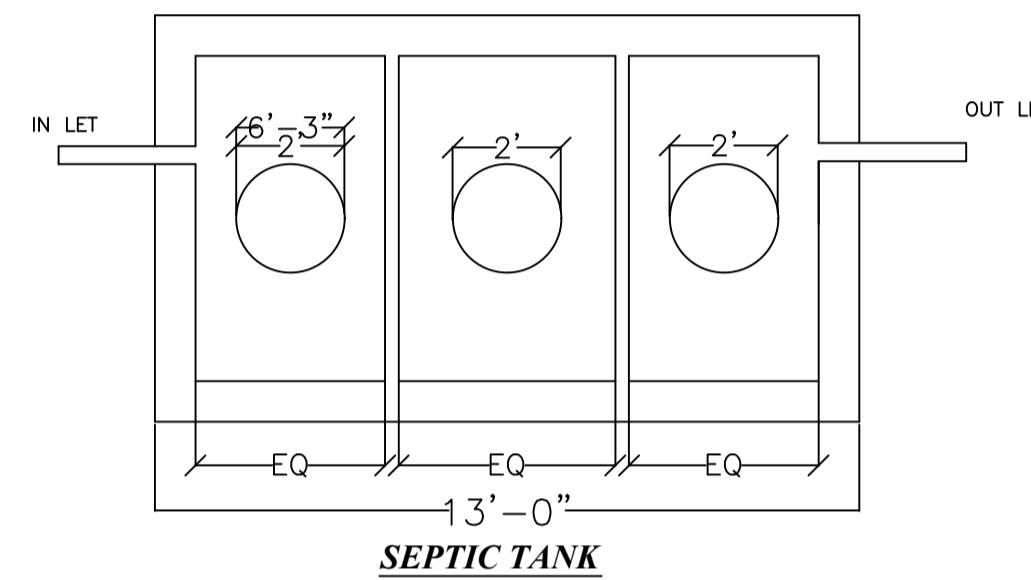

SEPTIC TANK

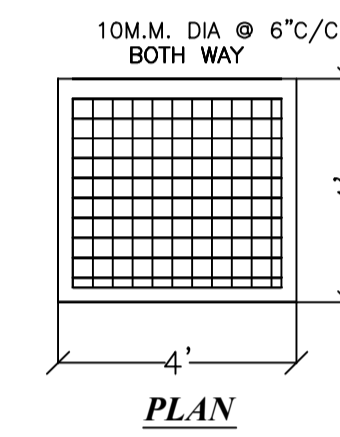

PLAN

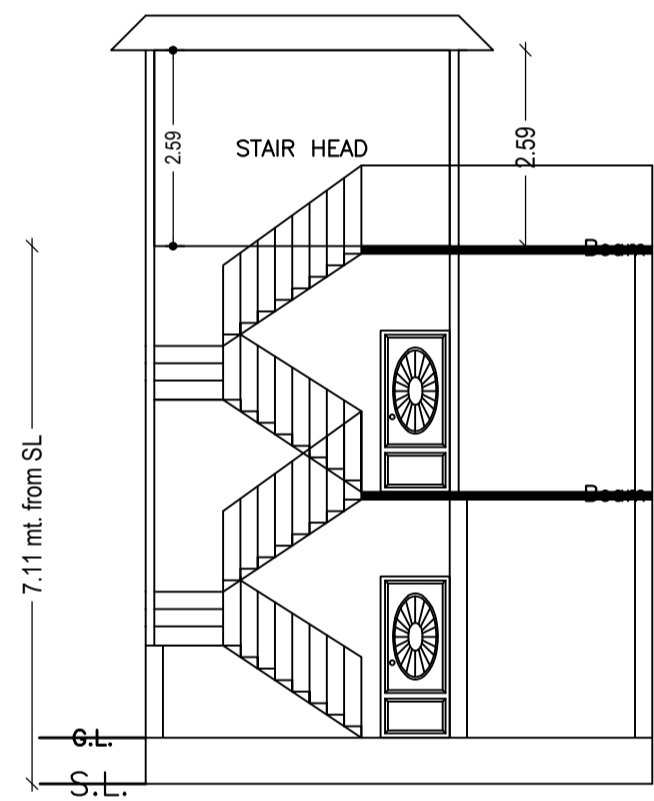

SECTION ON XX

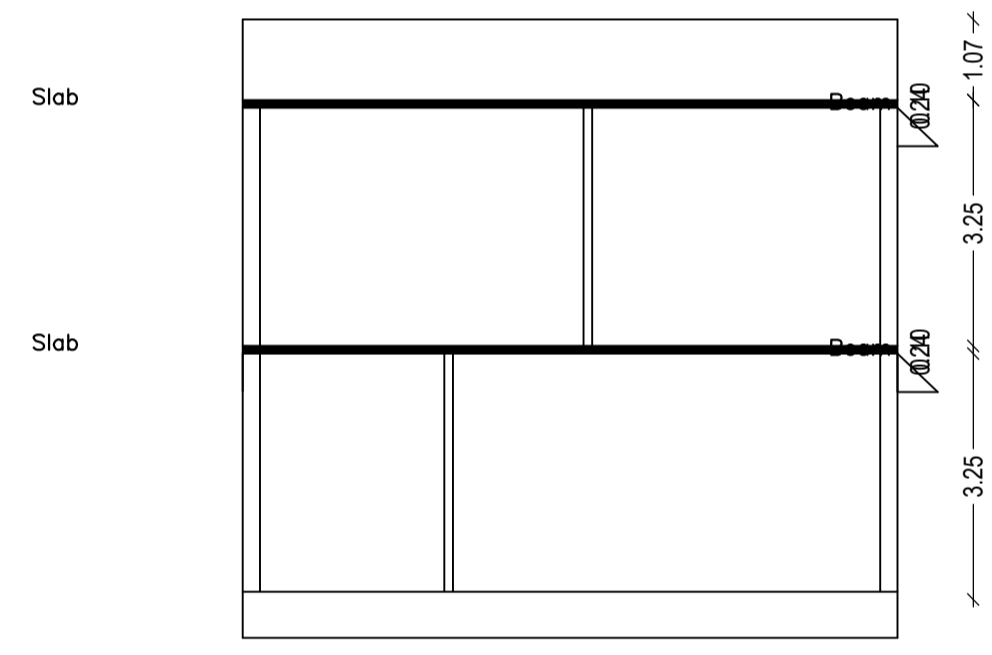

SECTION ON YY

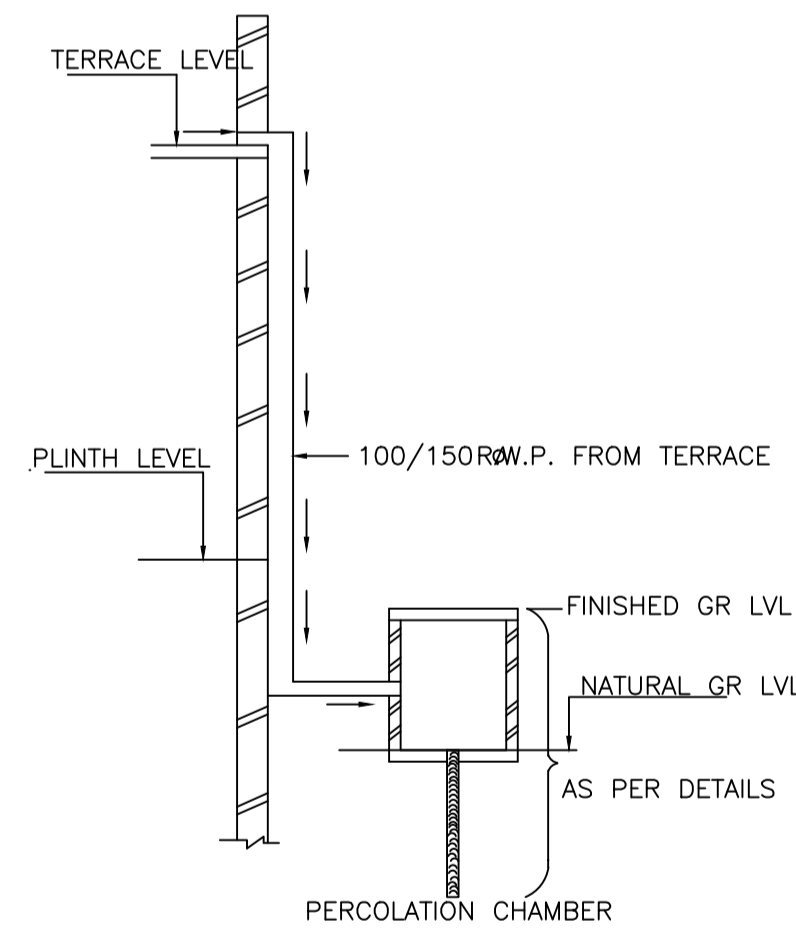

ROOF TOP RAIN WATER COLLECTION SYSTEM

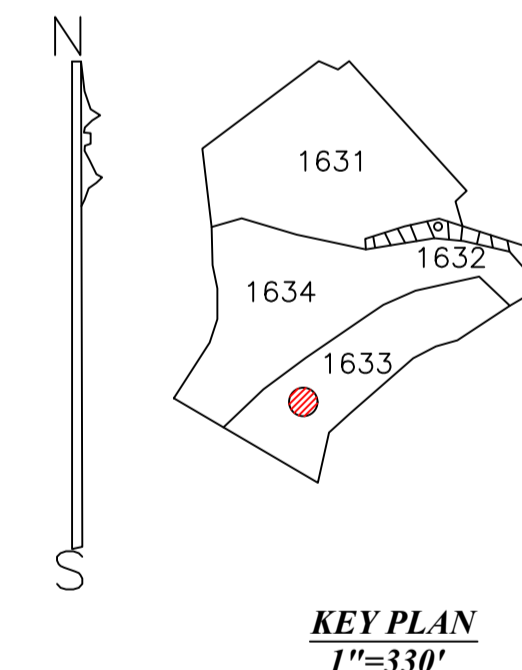

KEY PLAN 1"=330'

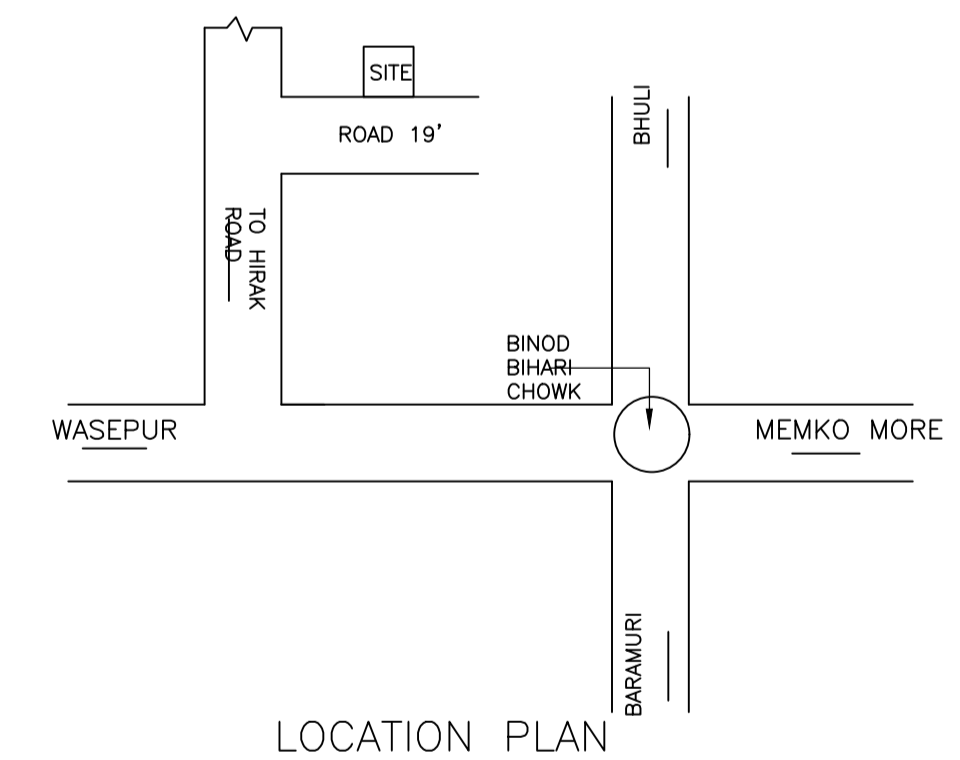

LOCATION PLAN

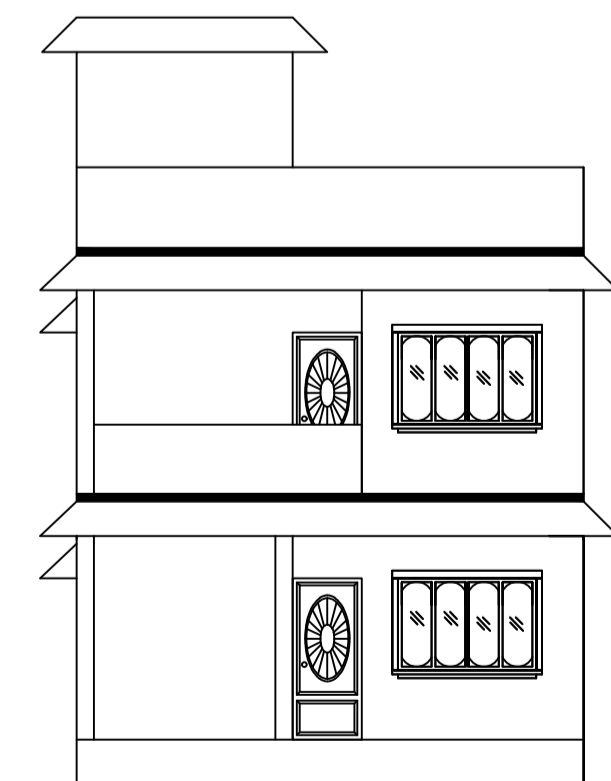

FRONT ELEVATION

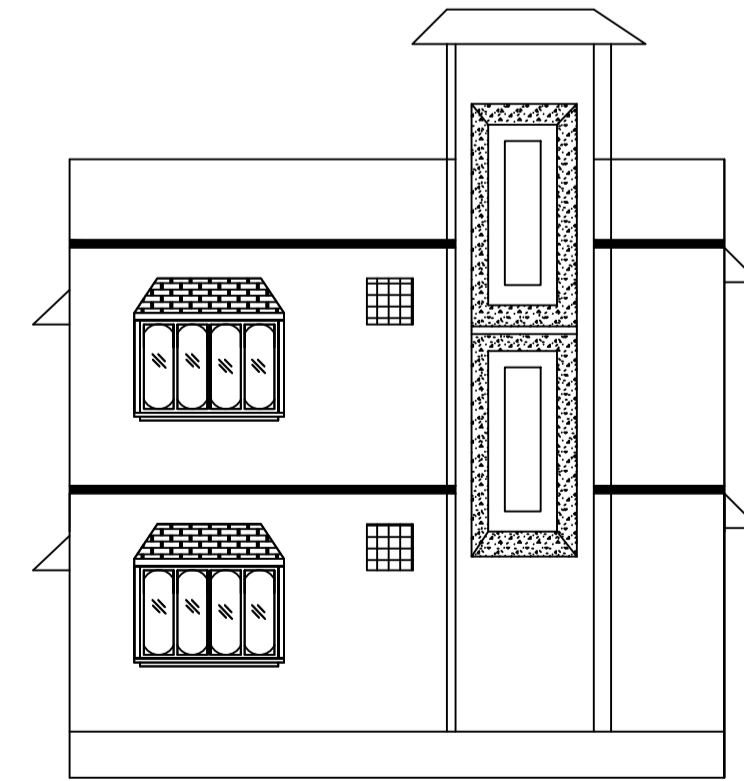

LEFT SIDE ELEVATION

LTP NAME AND SIGNATURE	STRUCTURAL ENG'S NAME AND SIGNATURE	BUILDER NAME AND SIGNATURE	DIGITAL SIGNATURE
SANTOSH MADA/ENG/0022/2019			