

AREA STATEMENT MINERAL AREA DEVELOPMENT AUTHORITY		VERSION NO.: 1.0.62
PROJECT DETAIL:		VERSION DATE: 16/10/2020
Region: JHARKHAND URBAN LOCAL BODIES	Plot Use: Residential	
District: DHANBAD	Plot SubUse: Bungalow/ Dwelling / Non Apartment	
Authority: MINERAL AREA DEVELOPMENT AUTHORITY	PlotNearby/ReligiousStructure: NA	
Inward No: MADA/BP/0351/2021	Plot/SubPlot No: NEW - 424.427 , OLD - 430	
Application Type: General Proposal	North: Plot No. - SARKAR DA	
Project Type: Building Permission	South: Road Width - 4.57M WIDE ROAD	
Nature of Development: New	East: Plot No. - MAHATO JEE	
Location of Development Area: Old Area	West: Road Width - 6.09M WIDE ROAD	
AREA DETAILS:		SQ.MT.
AREA OF PLOT (Minimum)	(A)	190.65
NET AREA OF PLOT(Gross Plot Area - Deduction from Gross Plot area)	(A-Deductions)	190.65
Deduction for Balance Plot Area(from Gross Plot Area)		
Common Plot		22.35
Total		22.35
BALANCE AREA OF PLOT (Net Plot Area - Recreational/Amenity space)	(A-Deductions)	168.30
PLOT AREA FOR COVERAGE(Net Plot Area)	(A-Deductions)	190.65
Plot Area for FAR (Net Plot Area + Road Widening Area)	(A-Deductions)	190.65
COVERAGE CHECK		
Permissible Coverage area (70.00 %)		133.45
Proposed Coverage Area (58.38 %)		111.31
Total Prop. Coverage Area (58.38 %)		111.31
Balance coverage area (11.61 %)		22.14
FAR CHECK		
Perm. FAR Area (1.80)		343.17
Total Perm. FAR area		343.17
Residential FAR		270.73
Proposed FAR Area		270.73
Total Proposed FAR Area		270.73
Consumed FAR (Factor)		1.42
Balance FAR Area		72.44
BUILT UP AREA CHECK		
Total Proposed BuiltUp Area		360.40
ARCHITECT (Regd)	Ashish kumar singh	
ENGINEER (Regd)		
SUPERVISOR (Regd)		
OWNER (Regd)	SMT PRIYANKA	
DEVELOPMENT AUTHORITY		LOCAL BODY

COLOR INDEX	
PLOT BOUNDARY	Black
ABUTTING ROAD	Green
PROPOSED CONSTRUCTION	Red
COMMON PLOT	Yellow
ROAD WIDENING AREA	Orange
EXISTING (To be retained)	Blue
EXISTING (To be demolished)	Light Blue

SCHEDULE OF DOOR:

BUILDING NAME	NAME	LENGTH	HEIGHT	NOS
AA (BB)	D	0.76	2.10	07
AA (BB)	D	0.91	2.10	08
AA (BB)	D	1.07	2.10	13

SCHEDULE OF WINDOW/VENTILATION:

BUILDING NAME	NAME	LENGTH	HEIGHT	NOS
AA (BB)	W	0.61	1.20	07
AA (BB)	W	0.90	1.20	02
AA (BB)	W	1.22	1.20	24

UnitBUA Table for Building :AA (BB)

FLOOR	Name	UnitBUA Type	UnitBUA Area	Carpet Area	No. of Rooms	No. of Tenement
GROUND FLOOR PLAN	SPLIT AA	FLAT	282.10	258.99	2	1
FIRST FLOOR PLAN	SPLIT AA	FLAT	0.00	0.00	11	0
SECOND FLOOR PLAN	SPLIT AA	FLAT	0.00	0.00	11	0
Terrace Floor	-	-	0.00	0.00	0	0
Total:	-	-	282.10	258.99	24	1

Building :AA (BB)

Floor Name	Total Built Up Area (Sq.mt.)	Deductions (Area in Sq.mt.)		Proposed FAR Area (Sq.mt.)	Total FAR Area (Sq.mt.)	Total Consumed Additional FAR Area (Sq.mt.)	Trmt (No.)
		Balcony	Parking				
Ground Floor	111.30	0.00	78.32	32.98	32.98	32.98	01
First Floor	124.55	5.68	0.00	118.87	118.87	118.87	00
Second Floor	124.55	5.68	0.00	118.87	118.87	118.87	00
Terrace Floor	0.00	0.00	0.00	0.00	0.00	0.00	00
Total:	360.40	11.36	78.32	270.72	270.72	270.72	01
Total Number of Same Buildings :	1						
Total:	360.40	11.36	78.32	270.72	270.72	270.72	01

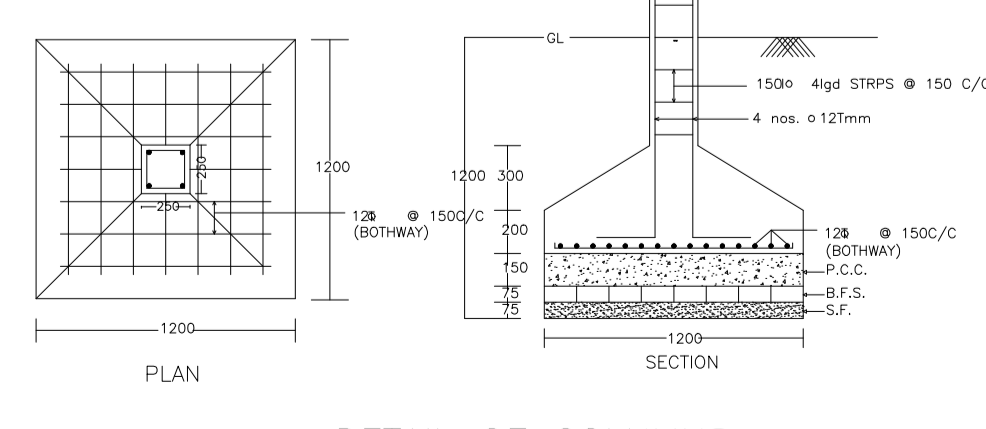
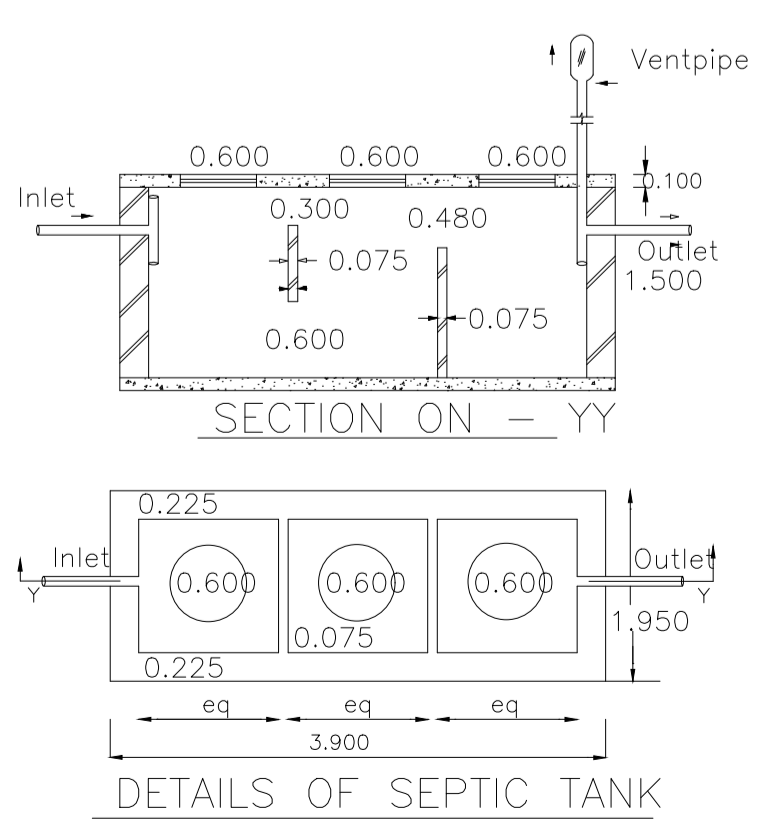
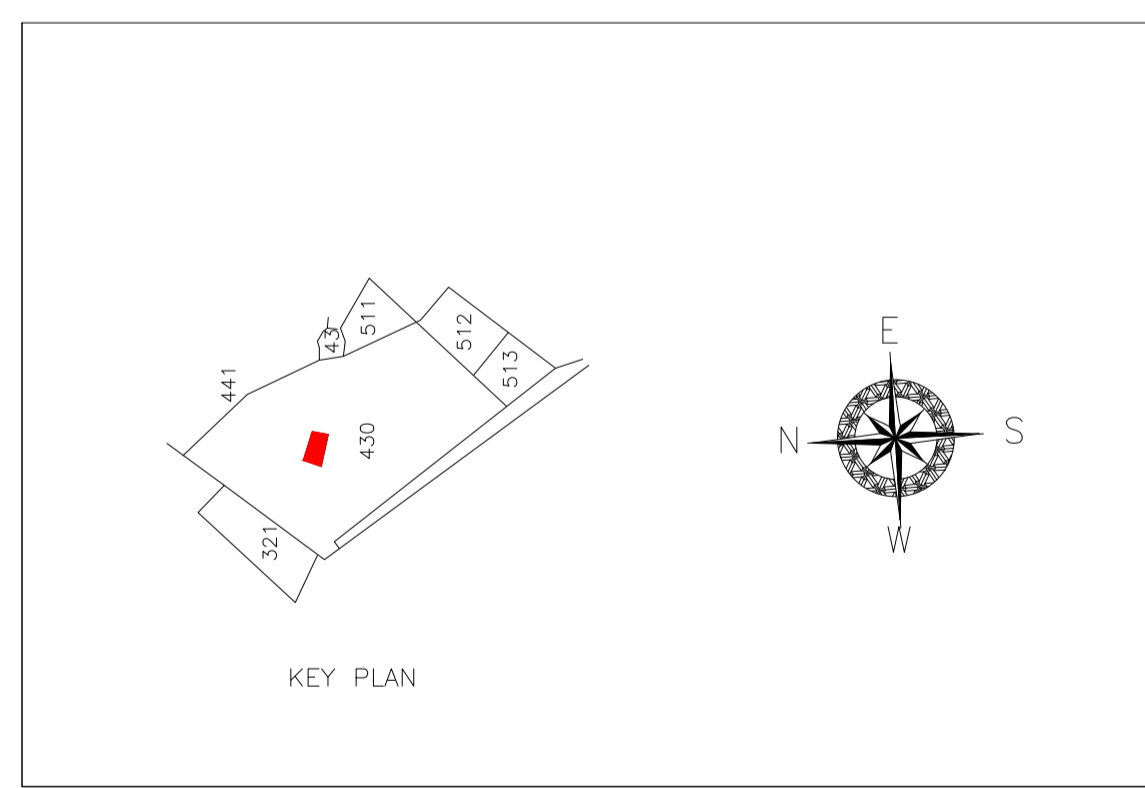
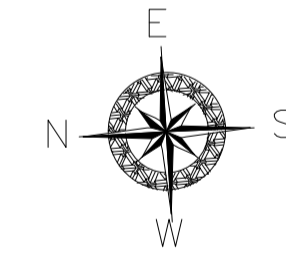
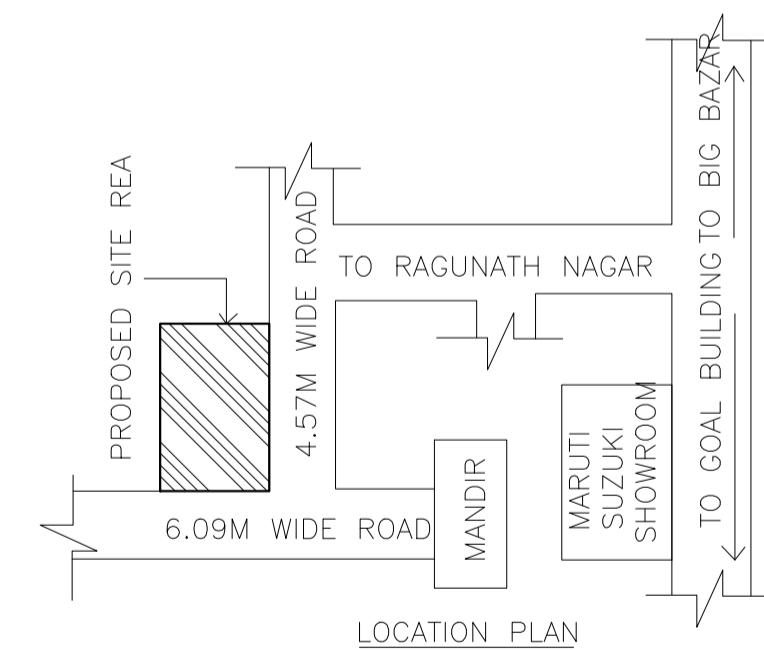
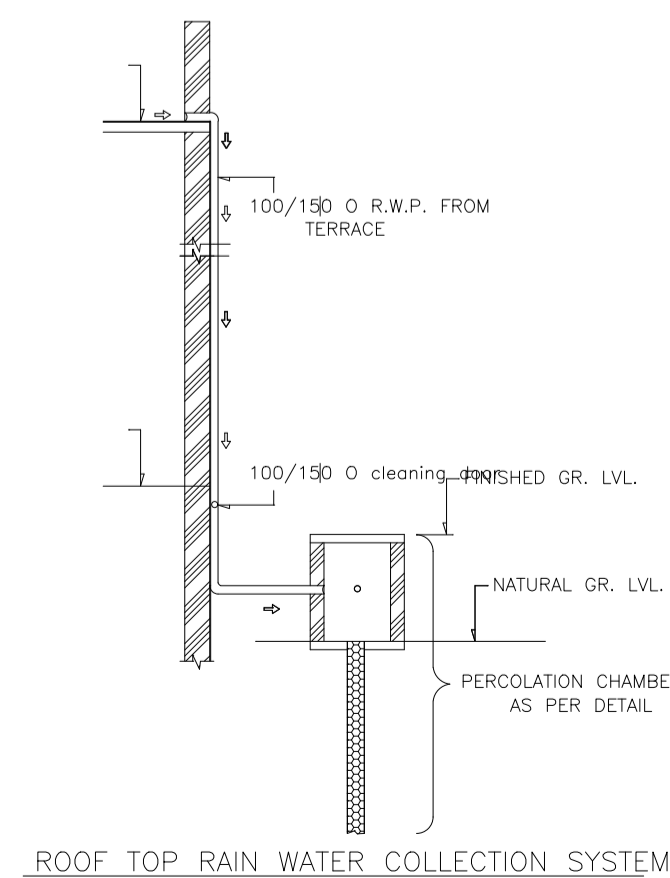

Buildingwise Floor FAR Details

Floor Name	Building Name AA (BB)		Total	
	Proposed Built Up Area (Sq.mt.)	Proposed FAR Area (Sq.mt.)	Total Proposed Built Up Area (Sq.mt.)	Total FAR Area (Sq.mt.)
Ground Floor	111.30	32.98	111.30	32.98
First Floor	124.55	118.87	124.55	118.87
Second Floor	124.55	118.87	124.55	118.87
Terrace Floor	0.00	0.00	0.00	0.00
Total :	360.40	270.72	360.40	270.72

Building USE/SUBUSE Details

Building Name	Building Use	Building SubUse	Building Structure
AA (BB)	Residential	Bungalow/ Dwelling / Non Apartment	Non-Highrise

FAR & Tenement Details (Table 4c-1)

Building	No. of Same Bldg	Total Built Up Area (Sq.mt.)	Deductions (Area in Sq.mt.)		Proposed FAR Area (Sq.mt.)	Total FAR Area (Sq.mt.)	Total Consumed Additional FAR Area (Sq.mt.)	Trmt (No.)
			Balcony	Parking				
AA (BB)	1	360.40	11.36	78.32	270.72	270.72	270.72	01
Grand Total :	1	360.40	11.36	78.32	270.72	270.72	270.72	01

Balcony Calculations Table

FLOOR	SIZE	AREA	TOTAL AREA
FIRST FLOOR PLAN	1.20 X 9.50 X 1 X 1	11.37	11.37
SECOND FLOOR PLAN	1.20 X 9.50 X 1 X 1	11.37	11.37
Total	-	-	22.74

LTP NAME AND SIGNATURE	STRUCTURAL ENG'S NAME AND SIGNATURE	BUILDER NAME AND SIGNATURE	DIGITAL SIGNATURE
Ashish kumar singh MADA/ARC/0028/2019			

Proposal Basic Information	
Proposal File No.	MADA/BP/0351/2021
Owner Name	SMT PRIYANKA
Khata No	NEW - 101 , OLD - 08
Plot No	NEW - 424.427 , OLD - 430
Village Name	Narayanpur
Use	Residential
SubUse	Bungalow/ Dwelling / Non Apartment

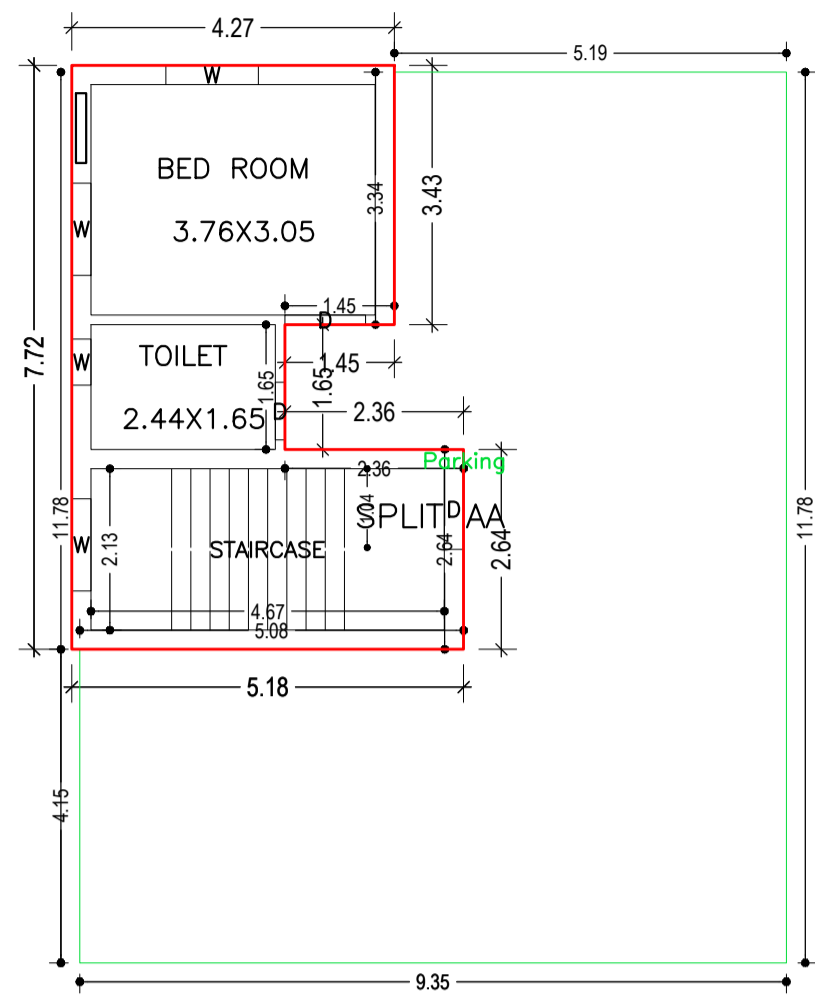

GROUND FLOOR PLAN
(Proposed)
(SCALE 1:100)

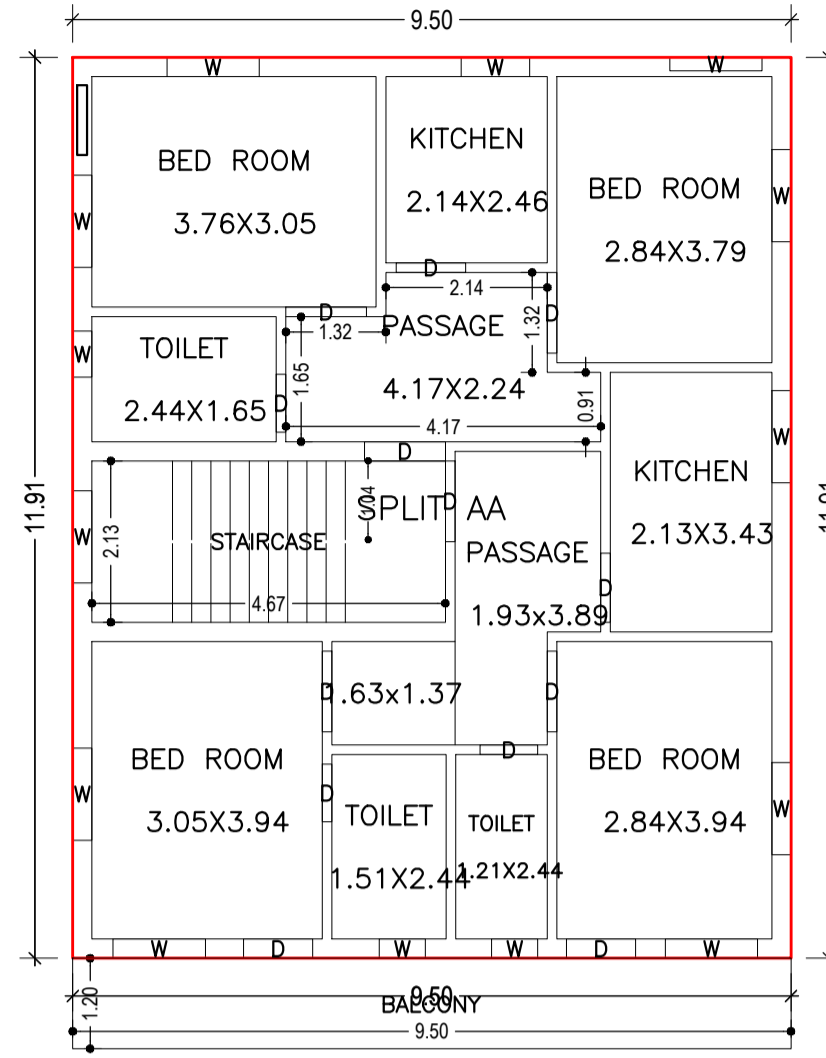

FIRST FLOOR PLAN
(Proposed)
(SCALE 1:100)

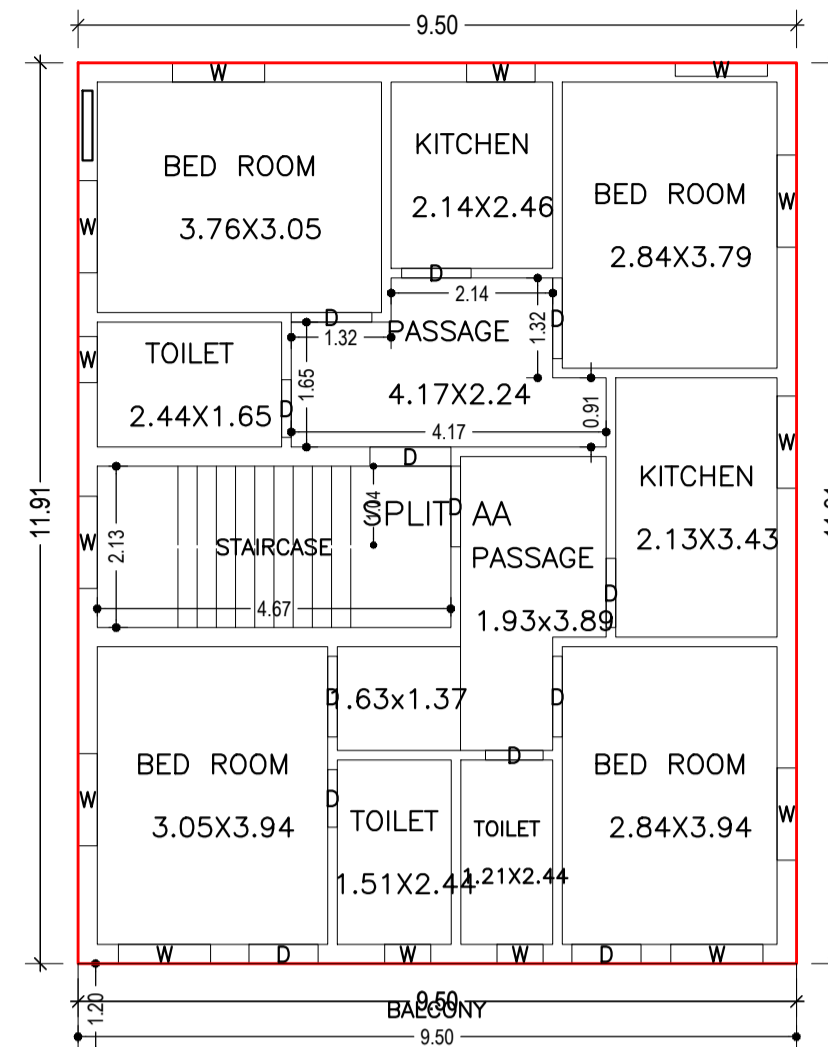

SECOND FLOOR PLAN
(Proposed)
(SCALE 1:100)

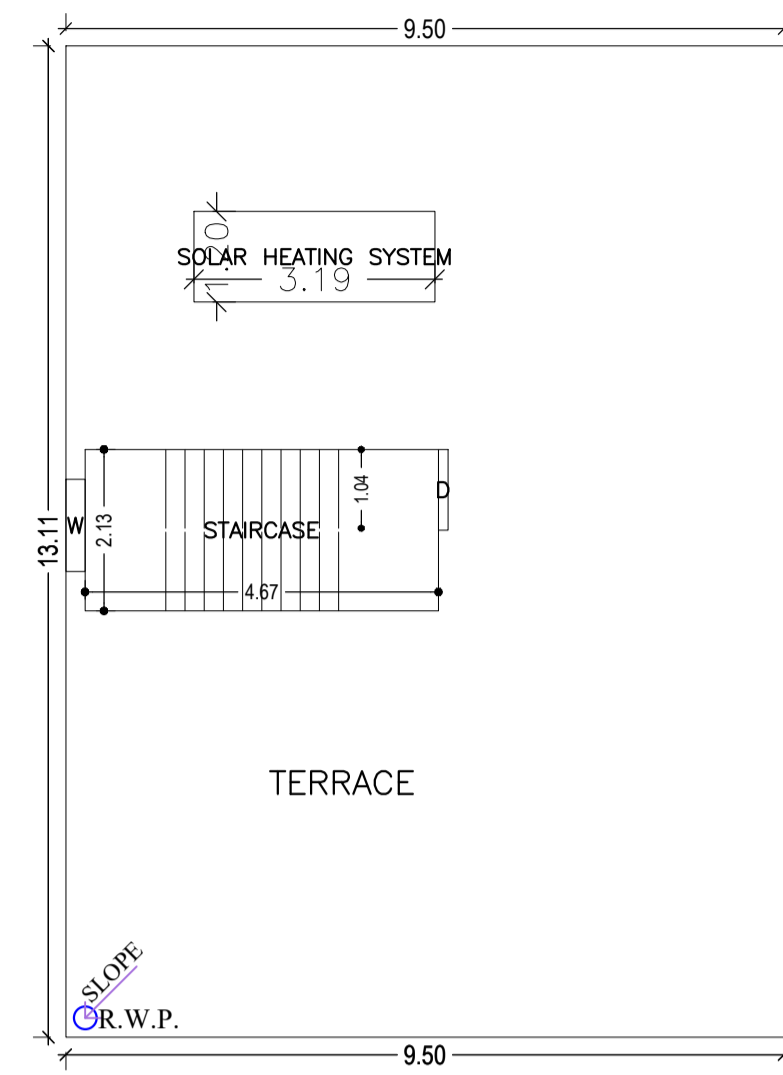

TERRACE FLOOR PLAN
(SCALE 1:100)

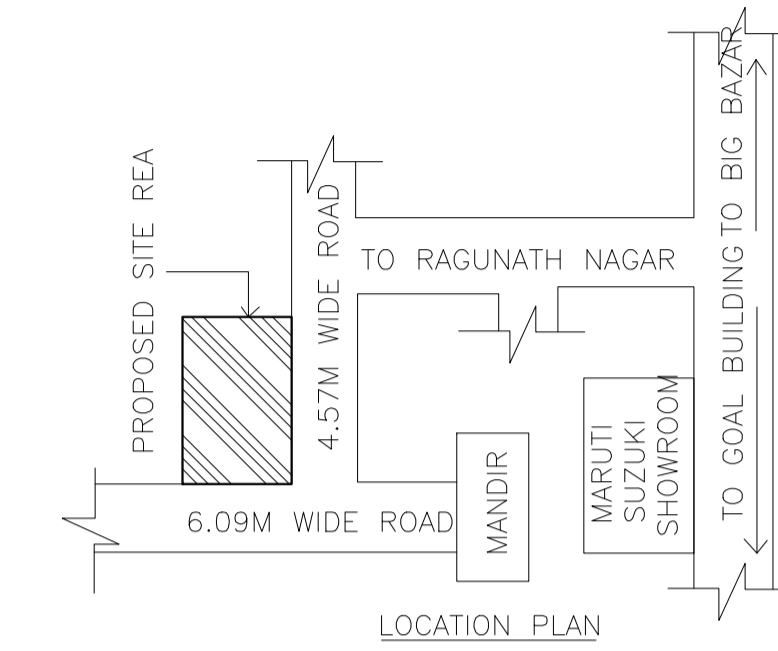

LOCATION PLAN

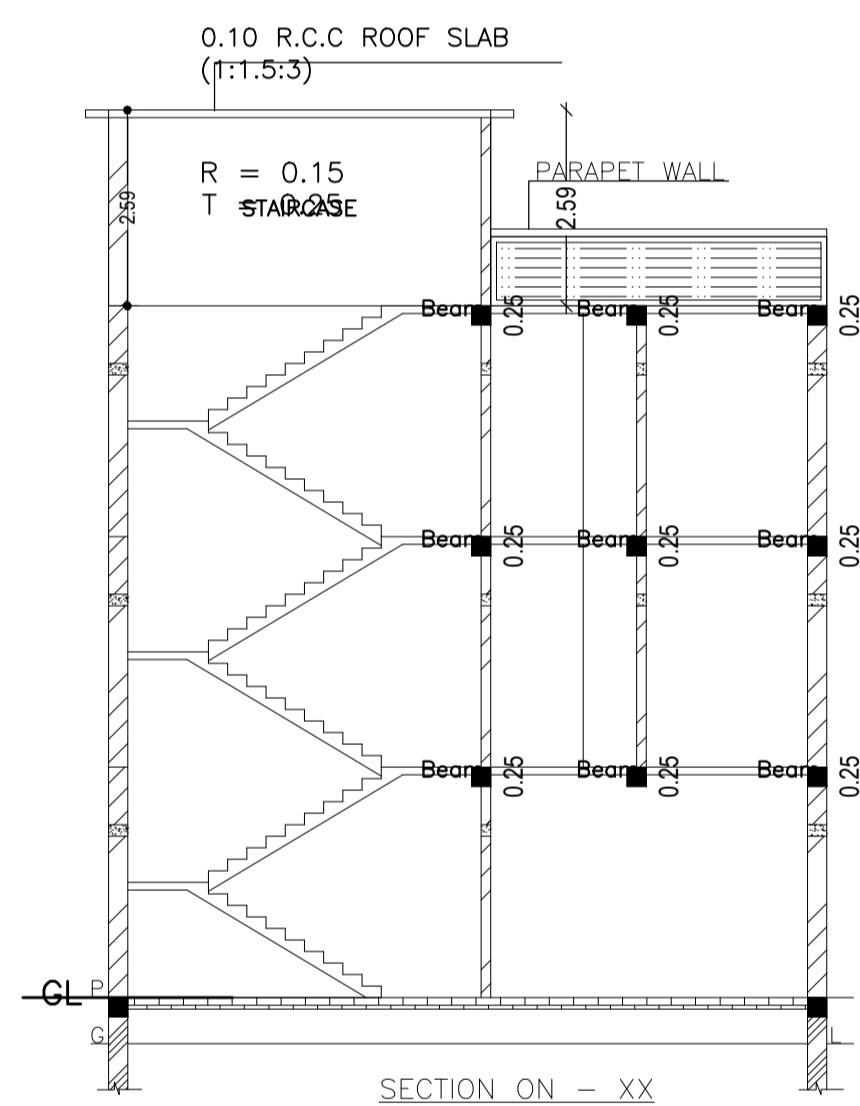
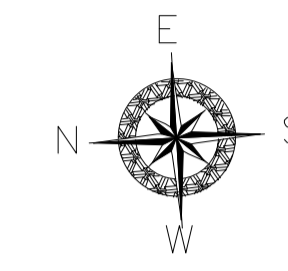

SECTION ON - XX

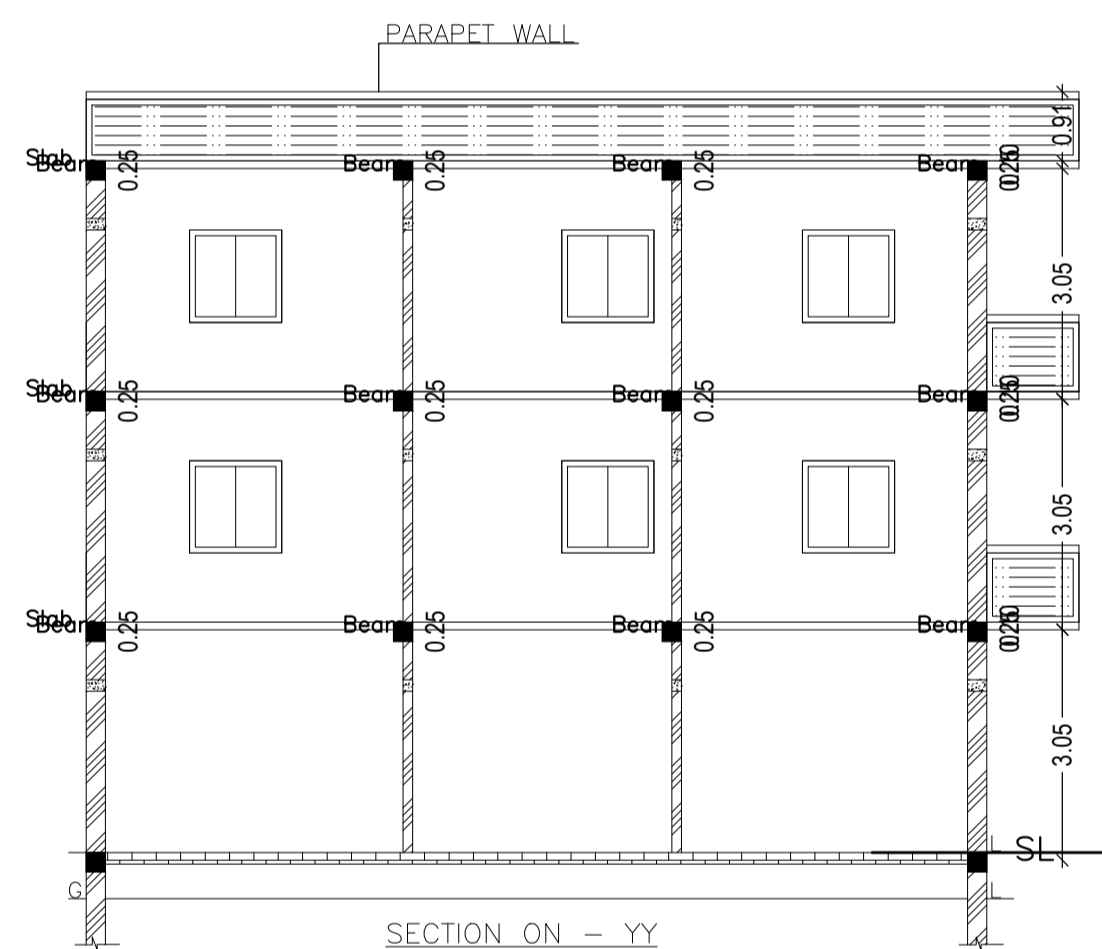

SECTION ON - YY

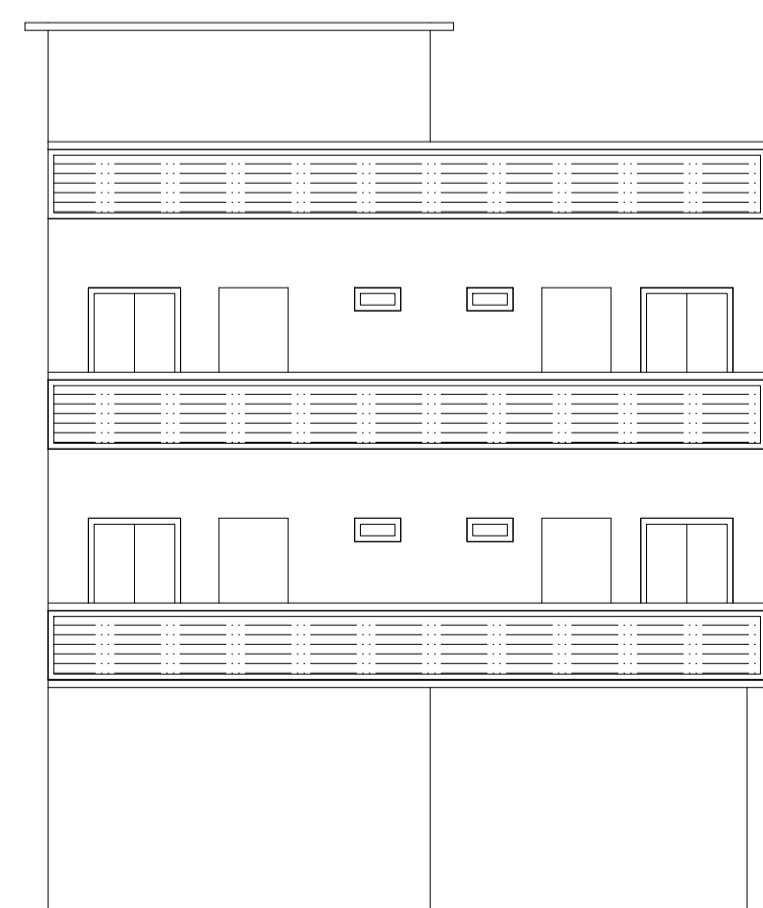

FRONT ELEVATION

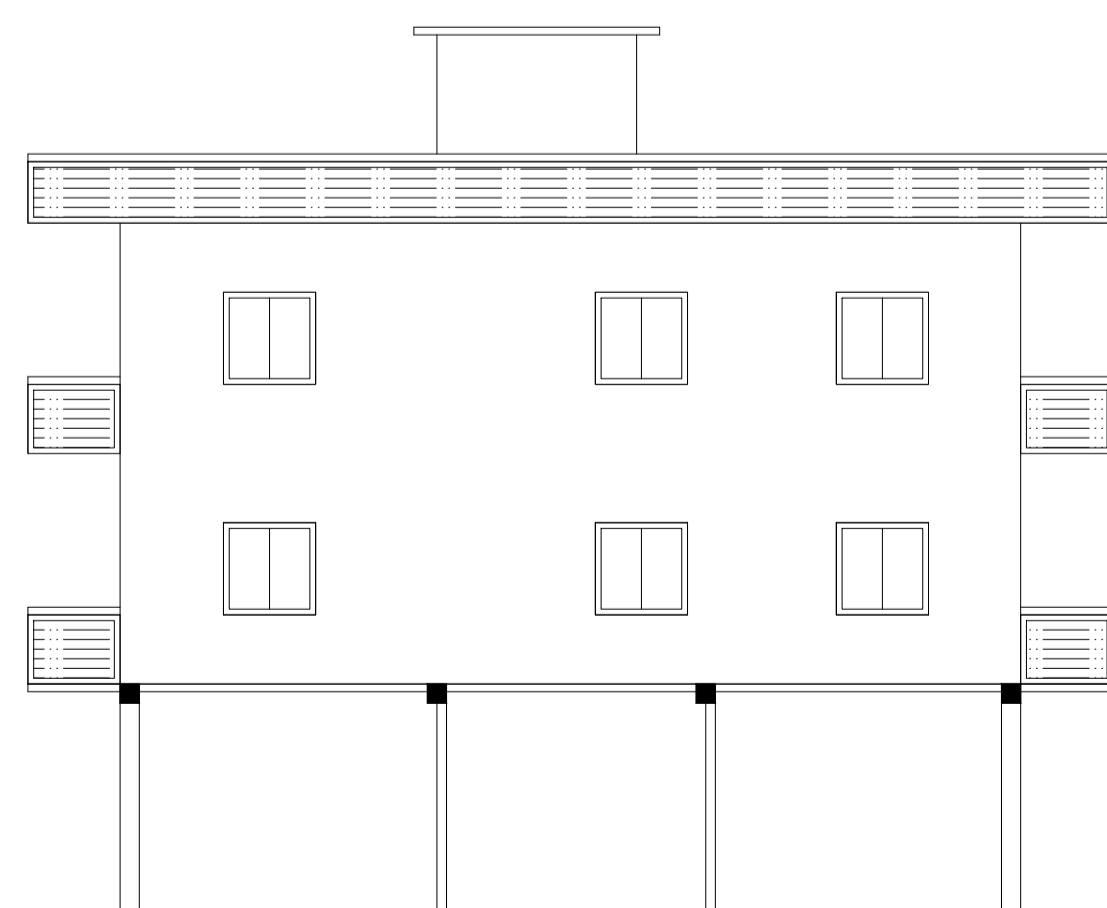

RIGHT ELEVATION

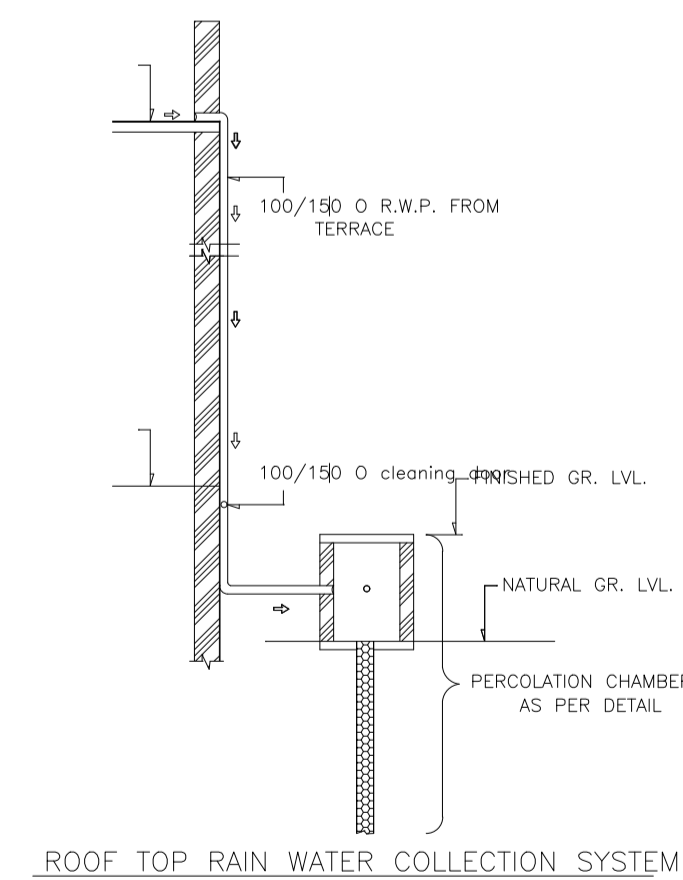

ROOF TOP RAIN WATER COLLECTION SYSTEM

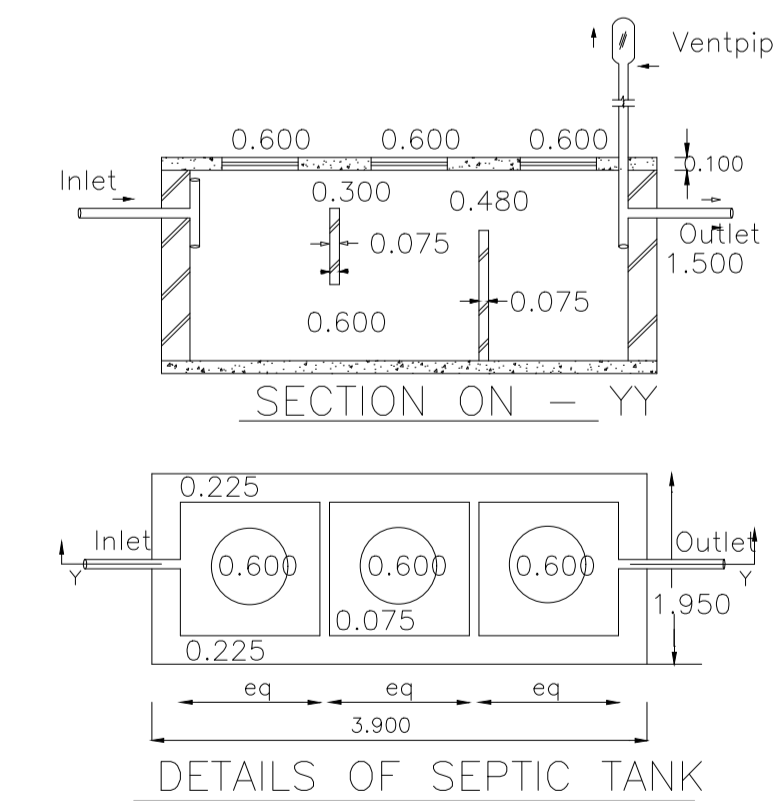

DETAILS OF SEPTIC TANK

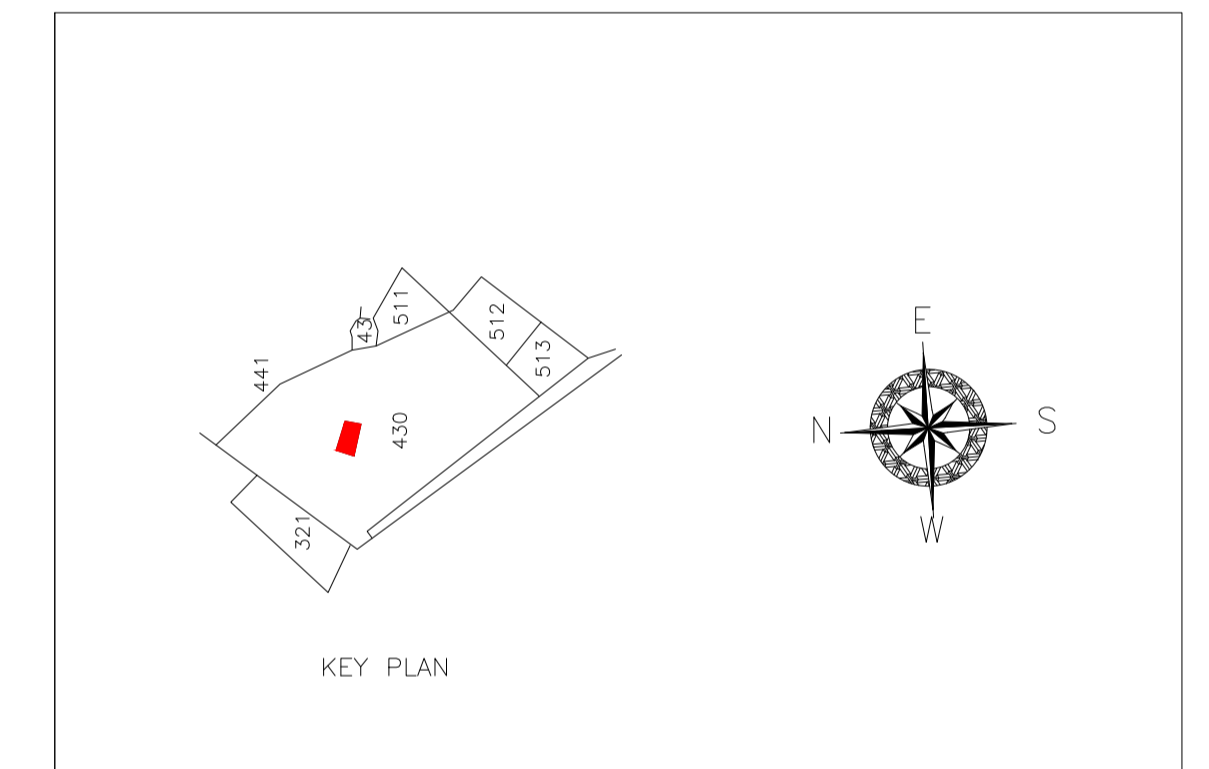

KEY PLAN

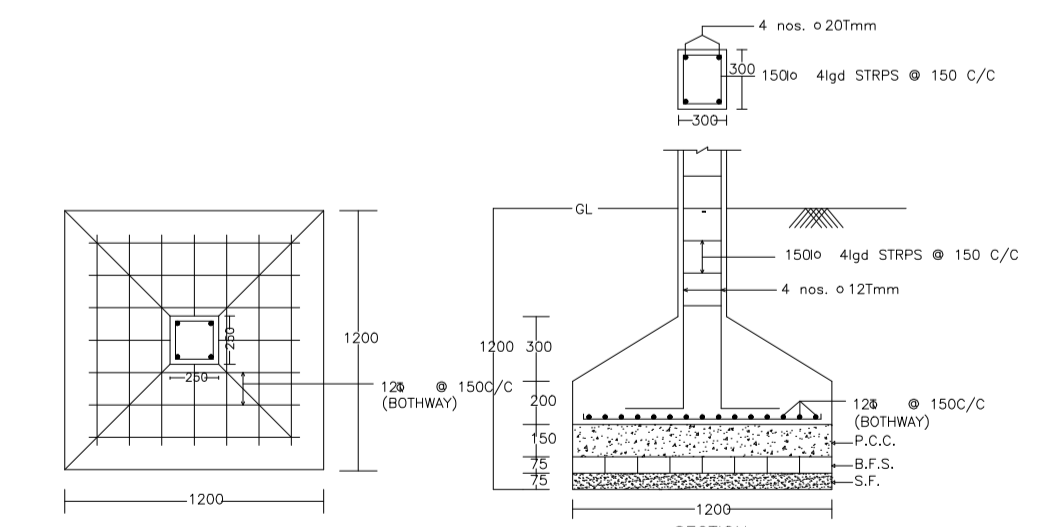

DETAIL OF COLUMNS

LTP NAME AND SIGNATURE	STRUCTURAL ENG'S NAME AND SIGNATURE	BUILDER NAME AND SIGNATURE	DIGITAL SIGNATURE
Ashish kumar singh MADA/ARC/0028/2019			