

Proposal Basic Information

Proposal File No.	MADA/BP/0306/2021
Owner Name	1. SMT. ASTHA AND 2. SHREE MADHUP SUKOON
Khata No	OLD KHATA NO-10, NEW KHATA NO-133
Plot No	OLD PLOT NO. 502, NEW PLOT NO. 1446
Village Name	Jialgora
Use	Residential
SubUse	Bungalow/ Dwelling / Non Apartment

AREA STATEMENT MINERAL AREA DEVELOPMENT AUTHORITY	VERSION NO.: 1.0.62	VERSION DATE: 16/10/2020
PROJECT DETAIL:		
Region: JHARKHAND URBAN LOCAL BODIES	Plot Use: Residential	
District: DHANBAD	Plot SubUse: Bungalow/ Dwelling / Non Apartment	
Authority: MINERAL AREA DEVELOPMENT AUTHORITY	PlotNearby/ReligiousStructure: NA	
Inward No: MADA/BP/0306/2021	Plot/SubPlot No: OLD PLOT NO. 502, NEW PLOT NO. 1446	
Application Type: General Proposal	North: Plot No. - SAME PLOT	
Project Type: Building Permission	South: Plot No. - SAME PLOT	
Nature of Development: New	East: Road Width - 6.10	
Location of Development Area: Old Area	West: Plot No. - SAME PLOT	
AREA DETAILS:		
AREA OF PLOT (Minimum)	(A)	103.82
NET AREA OF PLOT(Gross Plot Area - Deduction from Gross Plot area)	(A-Deductions)	103.82
Deduction for Balance Plot Area(from Gross Plot Area)		
Common Plot		10.38
Total		10.38
BALANCE AREA OF PLOT(Net Plot Area - Recreational/Amenity space)	(A-Deductions)	93.44
PLOT AREA FOR COVERAGE(Net Plot Area)	(A-Deductions)	103.82
Plot Area for FAR (Net Plot Area + RoadWidening Area)	(A-Deductions)	103.82
COVERAGE CHECK		
Permissible Coverage area (70.00 %)		72.67
Proposed Coverage Area (56.61 %)		58.77
Total Prop. Coverage Area (56.61 %)		58.77
Balance coverage area (13.39 %)		13.90
FAR CHECK		
Perm. FAR Area (2.50)		259.55
Total Perm. FAR area		259.55
Residential FAR		117.55
Proposed FAR Area		117.55
Total Proposed FAR Area		117.55
Consumed FAR (Factor)		1.13
Balance FAR Area		142.00
BUILT UP AREA CHECK		
Total Proposed BuiltUp Area		118.41
ARCHITECT (Regd)		RAM PRATAP SINGH
ENGINEER (Regd)		
SUPERVISOR (Regd)		
OWNER (Regd)		1. SMT. ASTHA AND 2. SHREE MADHUP SUKOON
DEVELOPMENT AUTHORITY		LOCAL BODY

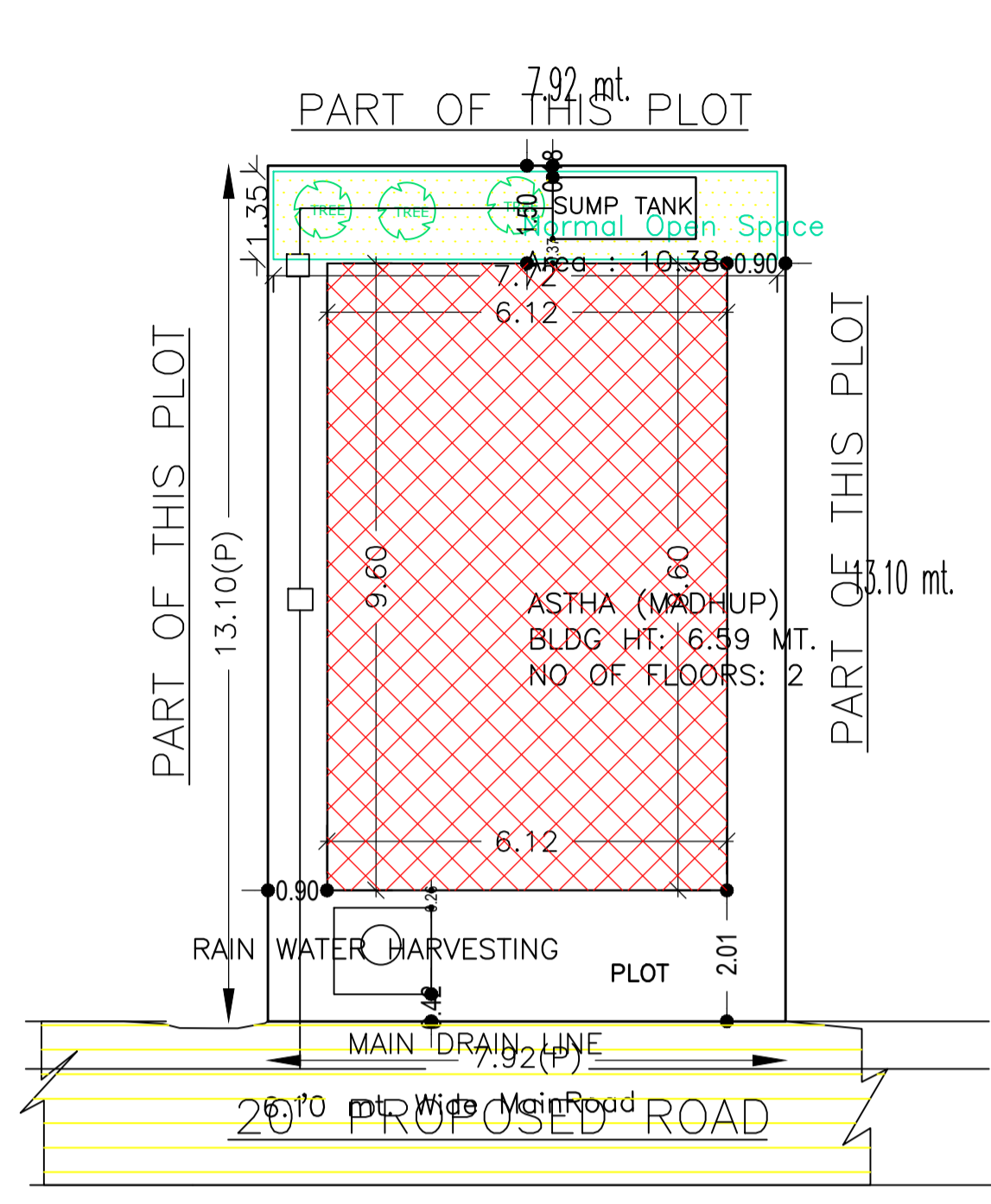

SITE PLAN  
SCALE - 1" = 16'-0"

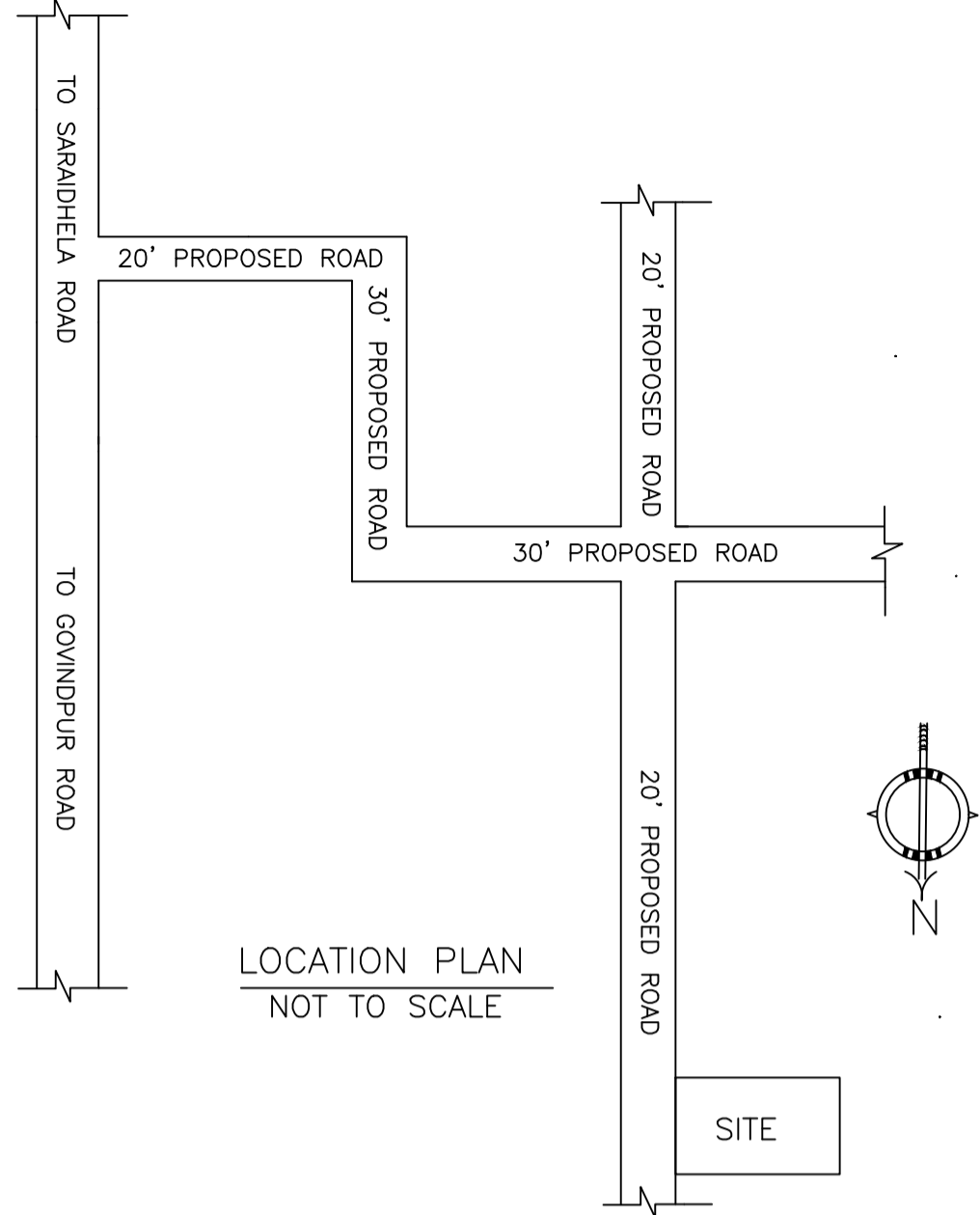

LOCATION PLAN  
NOT TO SCALE

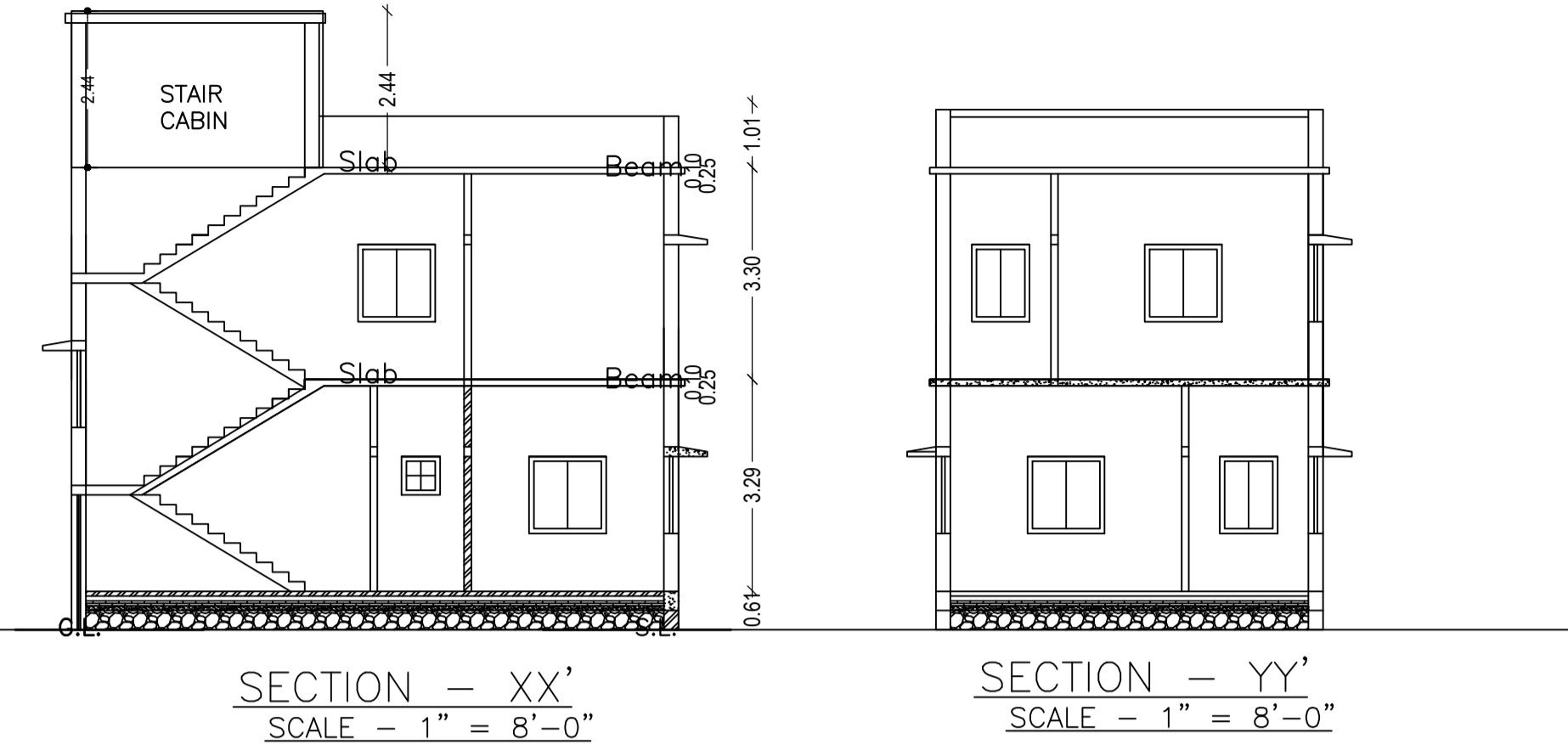

SECTION - XX'  
SCALE - 1" = 8'-0"

SECTION - YY'  
SCALE - 1" = 8'-0"

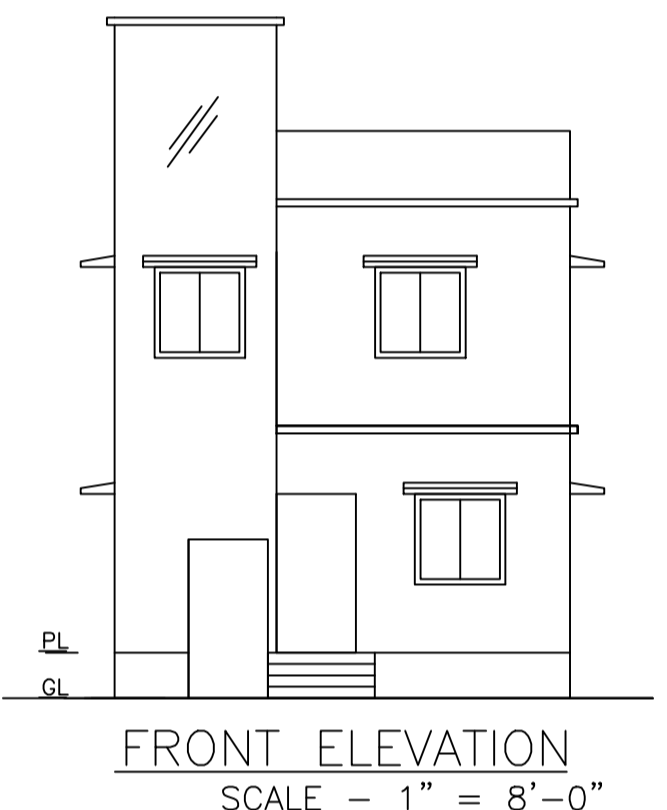

FRONT ELEVATION  
SCALE - 1" = 8'-0"

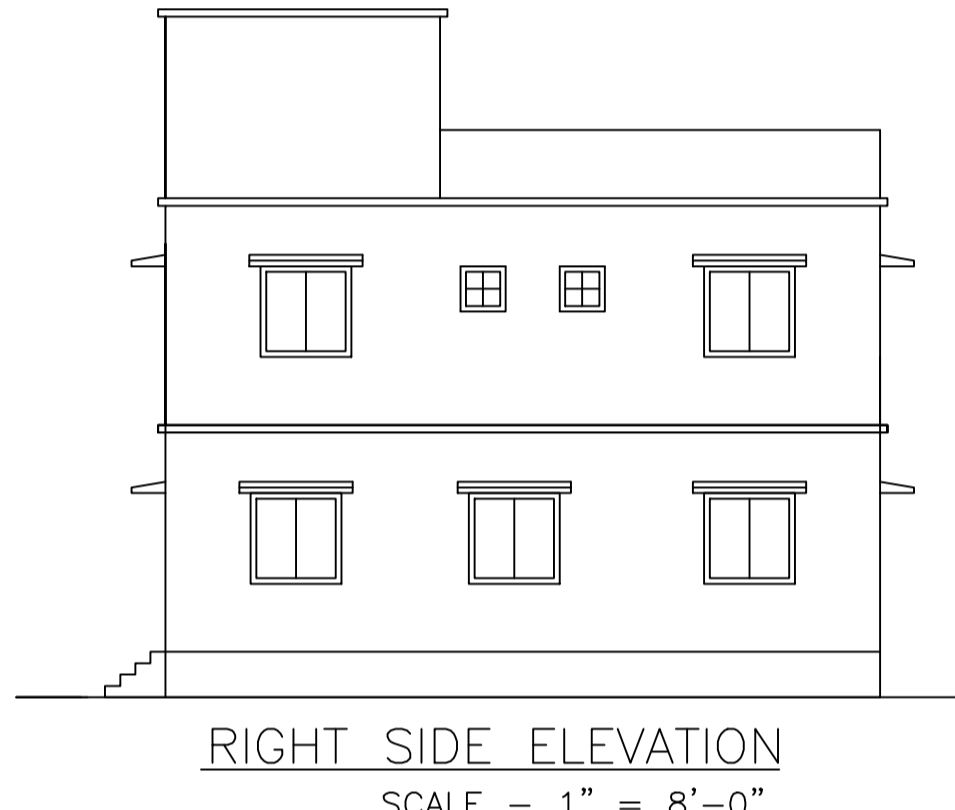

RIGHT SIDE ELEVATION  
SCALE - 1" = 8'-0"

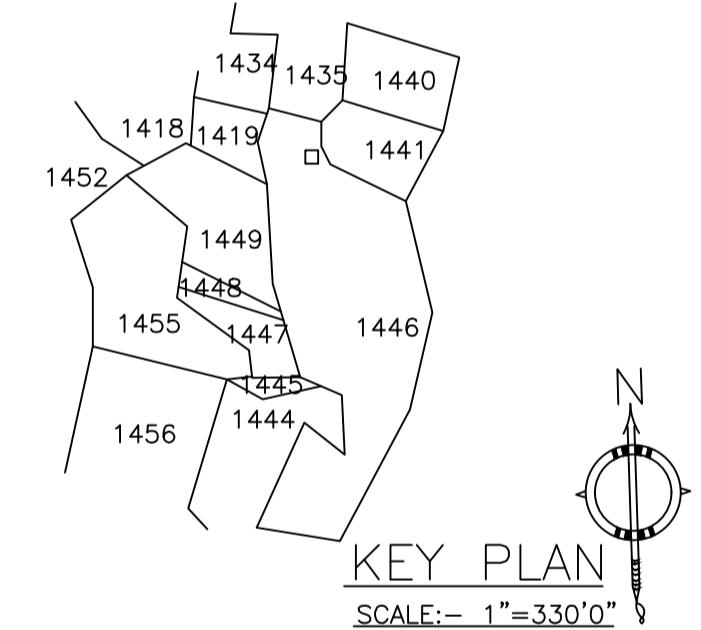

KEY PLAN  
SCALE:- 1"=330'0"

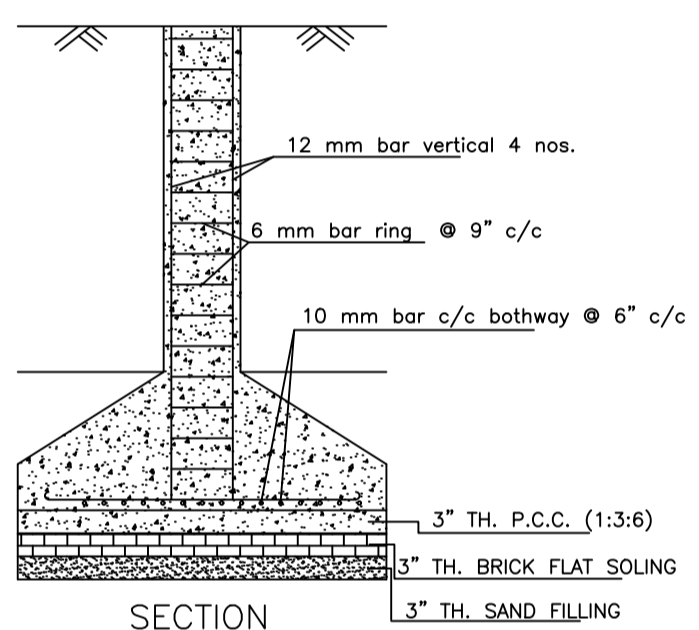

SECTION

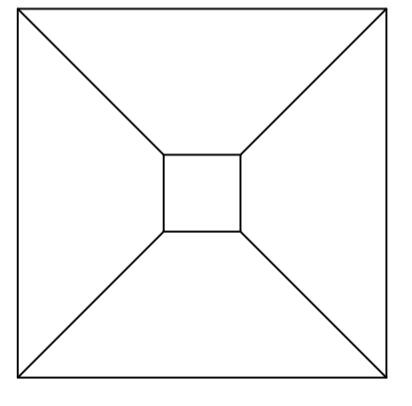

PLAN

DETAILS OF COLUMN FOUNDATION  
SCALE - 1" = 2'-0"

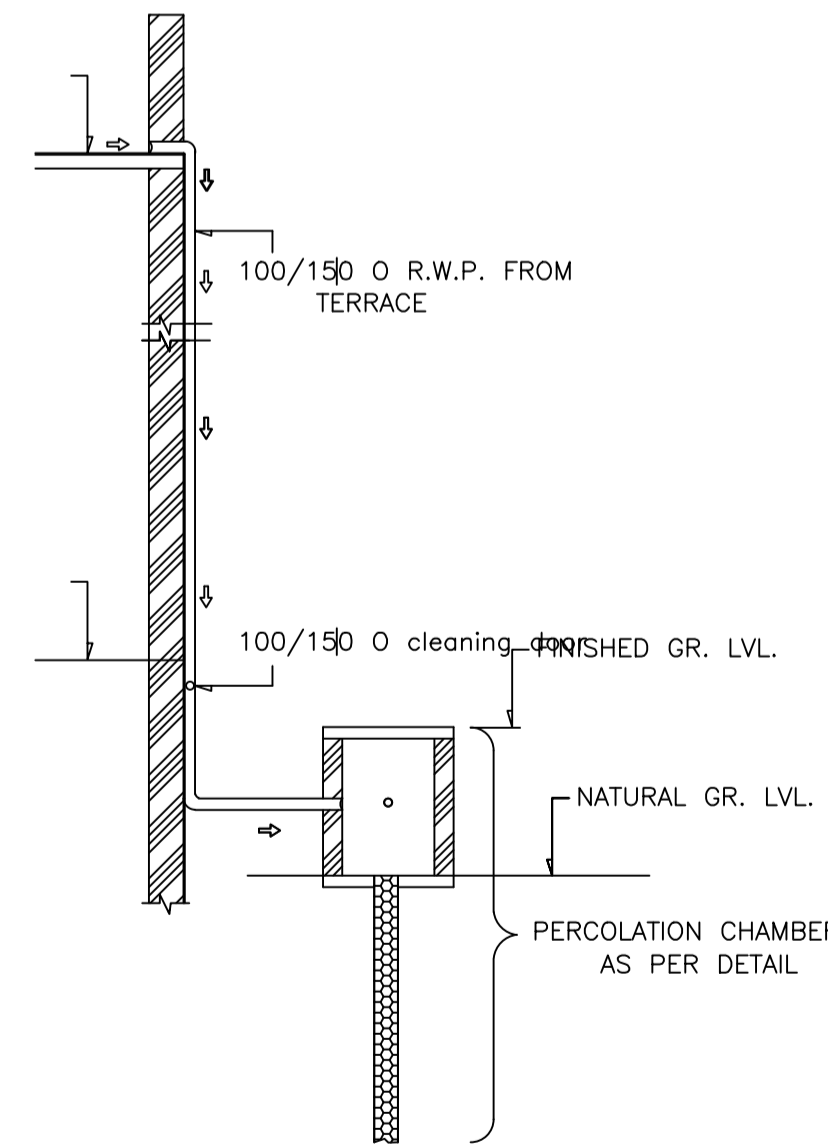

ROOF TOP RAIN WATER COLLECTION SYSTEM  
SCALE = 1" = 4'-0"

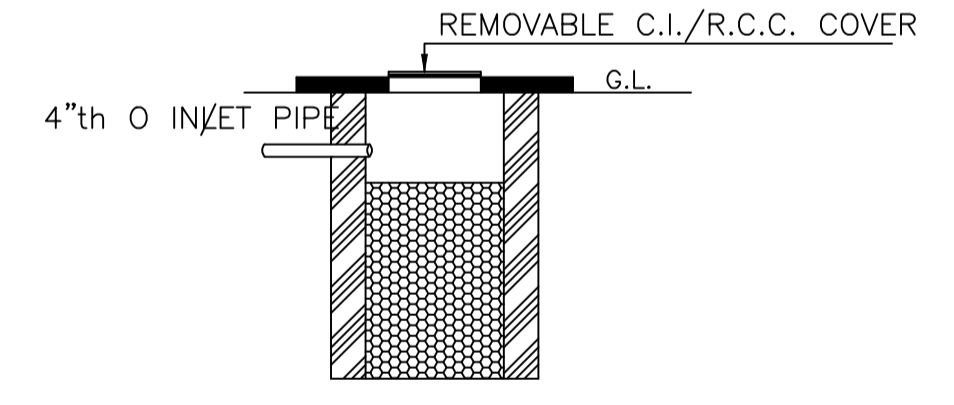

SECTION OF SOAK PIT

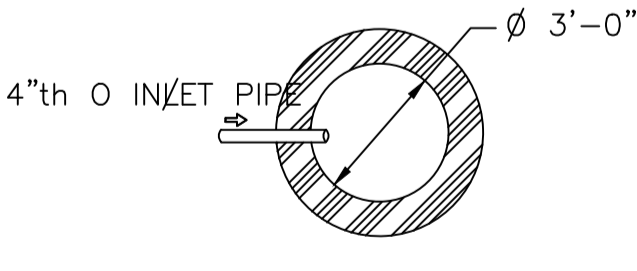

DETAILS OF SOAK PIT  
SCALE = 1" = 2'-0"

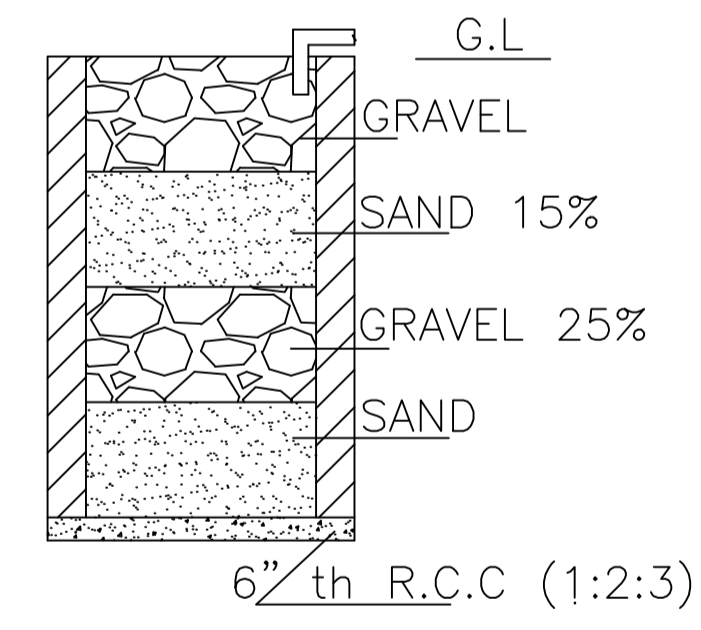

SECTION ON A - B

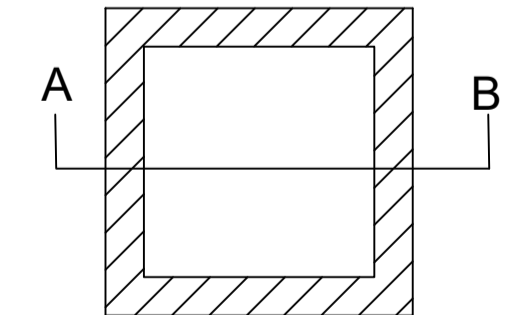

DETAILS DRAWING OF RAIN WATER HARVESTING  
SCALE:- 1"=2'-0"

COLOR INDEX

PLOT BOUNDARY	Black
ABUTTING ROAD	Green
PROPOSED CONSTRUCTION	Red
COMMON PLOT	Yellow
ROAD WIDENING AREA	Blue
EXISTING (To be retained)	Light Blue
EXISTING (To be demolished)	Dark Blue

Buildingwise Floor FAR Details

Floor Name	Building Name ASTHA (MADHUP)		Total	
	Proposed Built Up Area (Sq.mt.)	Proposed FAR Area (Sq.mt.)	Total Proposed Built Up Area (Sq.mt.)	Total FAR Area (Sq.mt.)
Ground Floor	59.64	58.77	59.64	58.77
First Floor	58.77	58.77	58.77	58.77
Terrace Floor	0.00	0.00	0.00	0.00
Total:	118.41	117.54	118.41	117.54

Building USE/SUBUSE Details

Building Name	Building Use	Building SubUse	Building Structure
ASTHA (MADHUP)	Residential	Residential Bldg/Apartment	Non-Highrise

Building :ASTHA (MADHUP)

Floor Name	Total Built Up Area (Sq.mt.)	Deductions (Area in Sq.mt.)	Proposed FAR Area (Sq.mt.)	Total FAR Area (Sq.mt.)	Total Consumed Additional FAR Area (Sq.mt.)	Trmnt (No.)
Ground Floor	59.64	0.87	58.77	58.77	58.77	01
First Floor	58.77	0.00	58.77	58.77	58.77	00
Terrace Floor	0.00	0.00	0.00	0.00	0.00	00
Total:	118.41	0.87	117.54	117.54	117.54	01
Total Number of Same Buildings	1					
Total:	118.41	0.87	117.54	117.54	117.54	01

SCHEDULE OF DOOR:

BUILDING NAME	NAME	LENGTH	HEIGHT	NOS
ASTHA (MADHUP)	D	0.76	2.10	03
ASTHA (MADHUP)	D	0.91	2.10	02
ASTHA (MADHUP)	D	1.07	2.10	04

SCHEDULE OF WINDOW/VENTILATION:

BUILDING NAME	NAME	LENGTH	HEIGHT	NOS
ASTHA (MADHUP)	w	0.61	1.20	03
ASTHA (MADHUP)	w	0.91	1.20	02
ASTHA (MADHUP)	w	1.22	1.20	12

UnitBUA Table for Building :ASTHA (MADHUP)

FLOOR	Name	UnitBUA Type	UnitBUA Area	Carpel Area	No. of Rooms	No. of Tenement
GROUND FLOOR PLAN	SPLIT 1	FLAT	117.55	117.46	5	1
FIRST FLOOR PLAN	SPLIT 1	FLAT	0.00	0.00	6	0
Total:	-	-	117.55	117.46	11	1

FAR & Tenement Details (Table 4c-1)

Building	No. of Same Bldg	Total Built Up Area (Sq.mt.)	Deductions (Area in Sq.mt.)	Proposed FAR Area (Sq.mt.)	Total FAR Area (Sq.mt.)	Total Consumed Additional FAR Area (Sq.mt.)	Trmnt (No.)
ASTHA (MADHUP)	1	118.41	0.87	117.54	117.54	117.54	01
Grand Total:	1	118.41	0.87	117.54	117.54	117.54	01

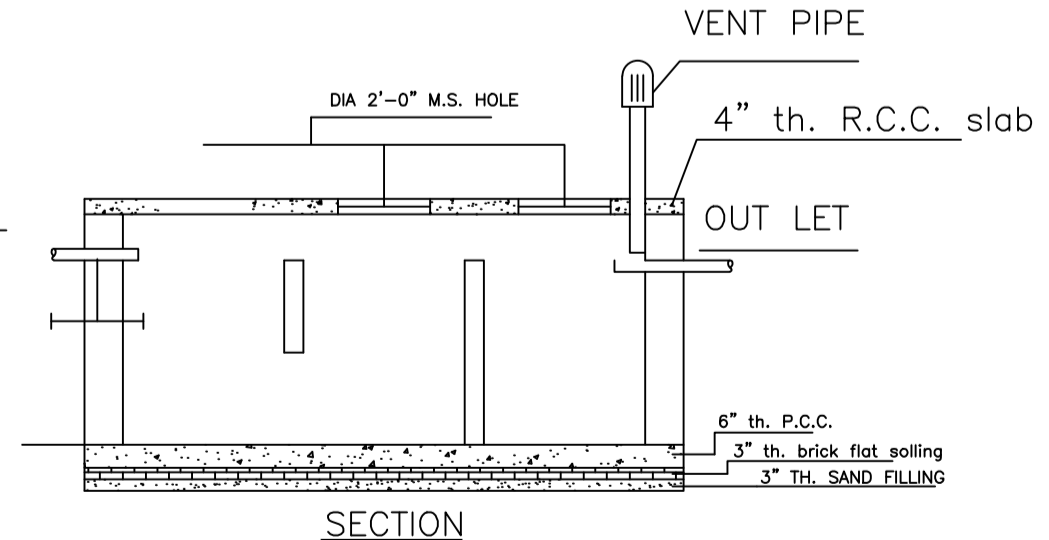

DETAILS OF SEPTIC TANK  
SCALE - 1" = 4'-0"

LTP NAME AND SIGNATURE	STRUCTURAL ENG'S NAME AND SIGNATURE	BUILDER NAME AND SIGNATURE	DIGITAL SIGNATURE
RAM PRATAP SINGH MADA/ARC/0024/2019			

Proposal Basic Information	
Proposal File No.	MADA/BP/0306/2021
Owner Name	1. SMT. ASTHA AND 2. SHREE MADHUP SUKOON
Khata No	OLD KHATA NO-10, NEW KHATA NO-133
Plot No	OLD PLOT NO. 502, NEW PLOT NO. 1446
Village Name	Jialgora
Use	Residential
SubUse	Bungalow/ Dwelling / Non Apartment

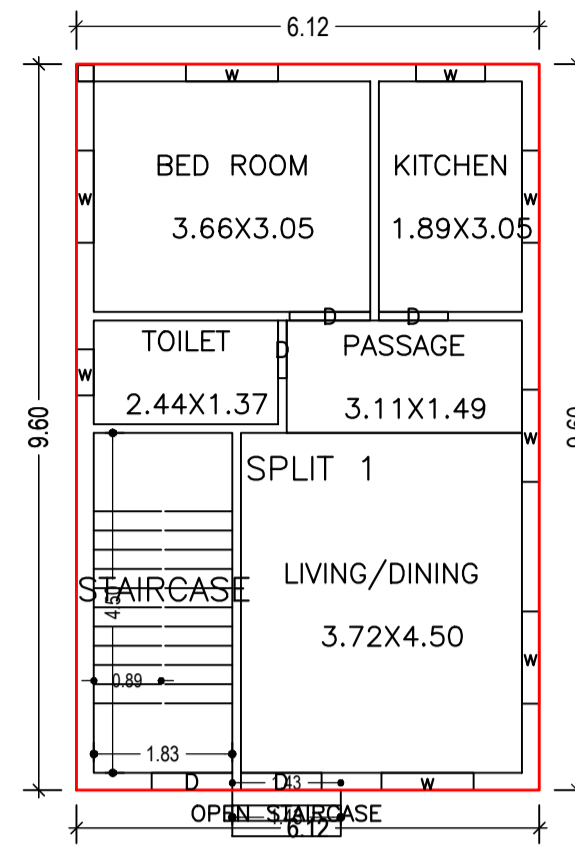

GROUND FLOOR PLAN  
(Proposed)  
SCALE 1:100

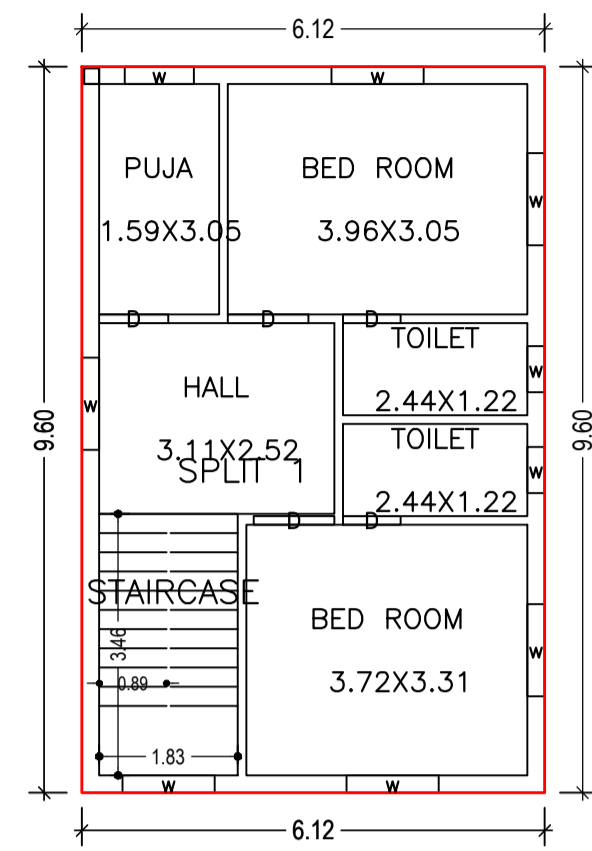

FIRST FLOOR PLAN  
(Proposed)  
SCALE 1:100

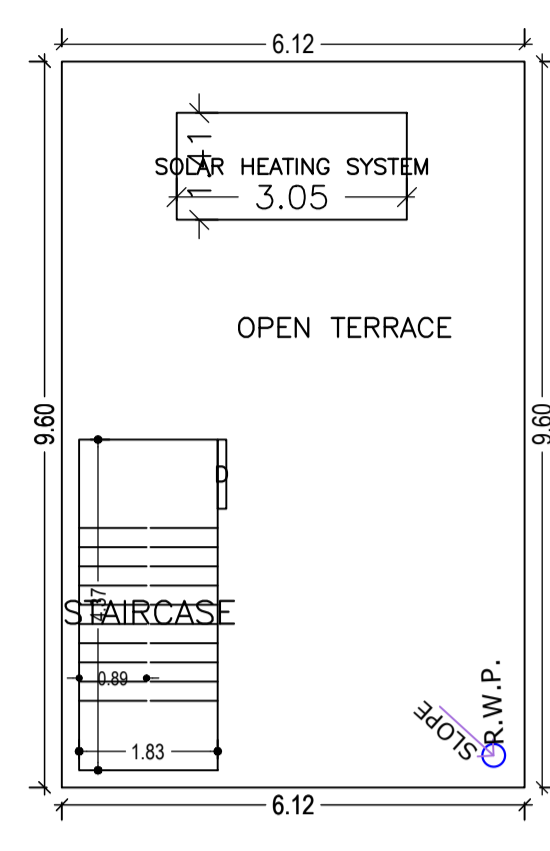

TERRACE FLOOR PLAN  
SCALE 1:100

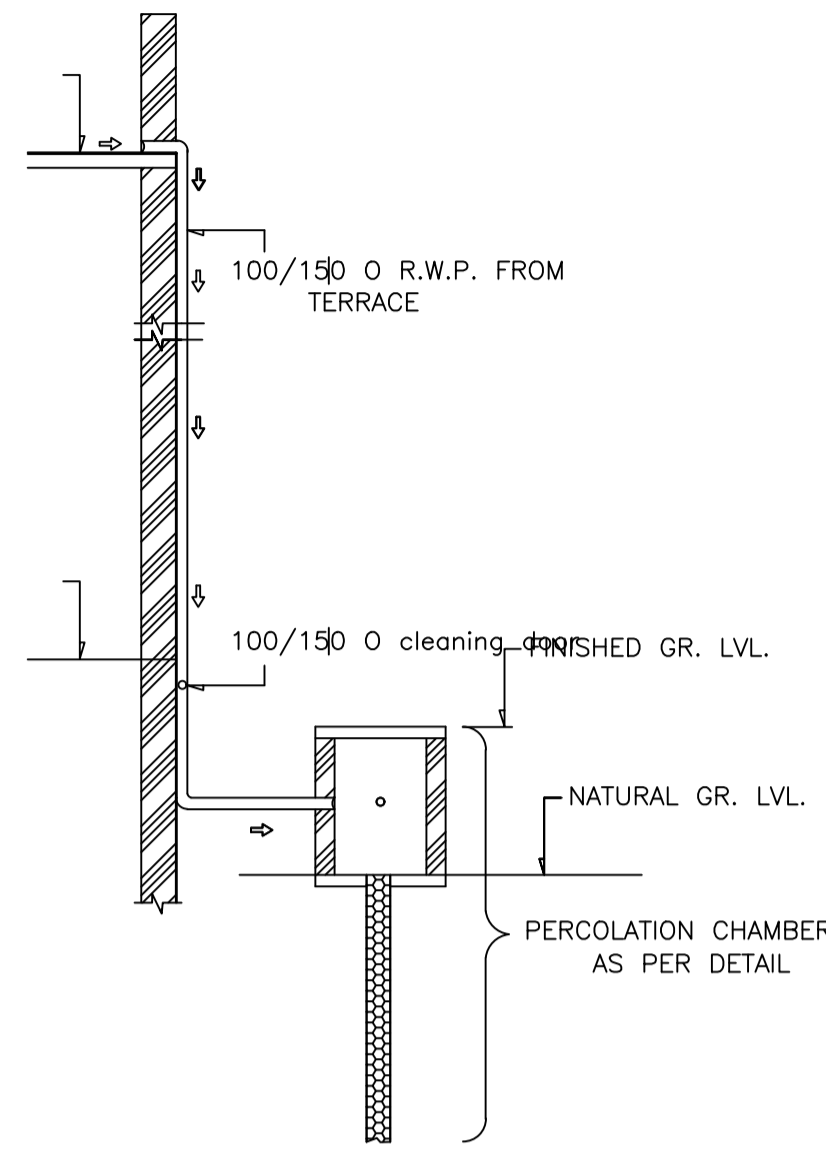

ROOF TOP RAIN WATER COLLECTION SYSTEM  
SCALE = 1" = 4'-0"

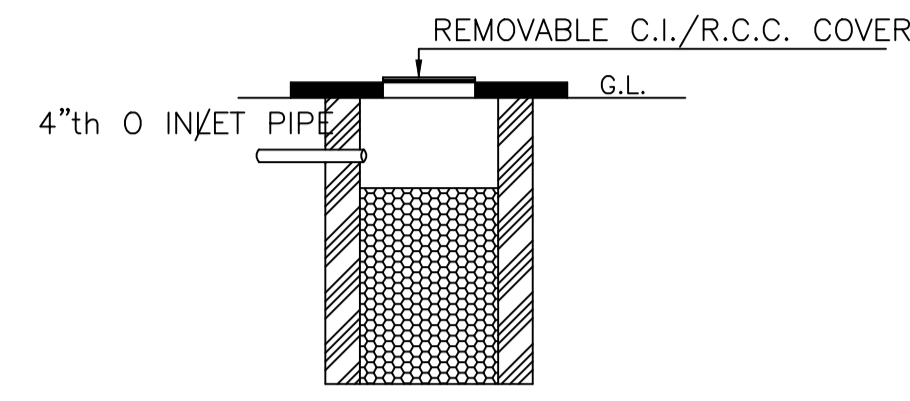

SECTION OF SOAK PIT

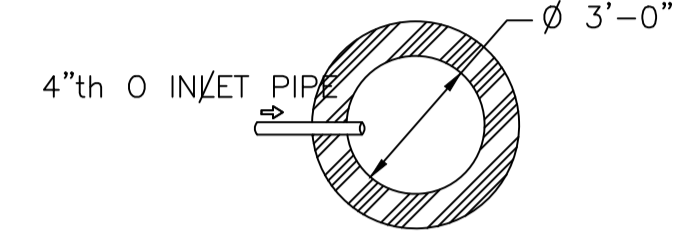

DETAILS OF SOAK PIT  
SCALE = 1" = 2'-0"

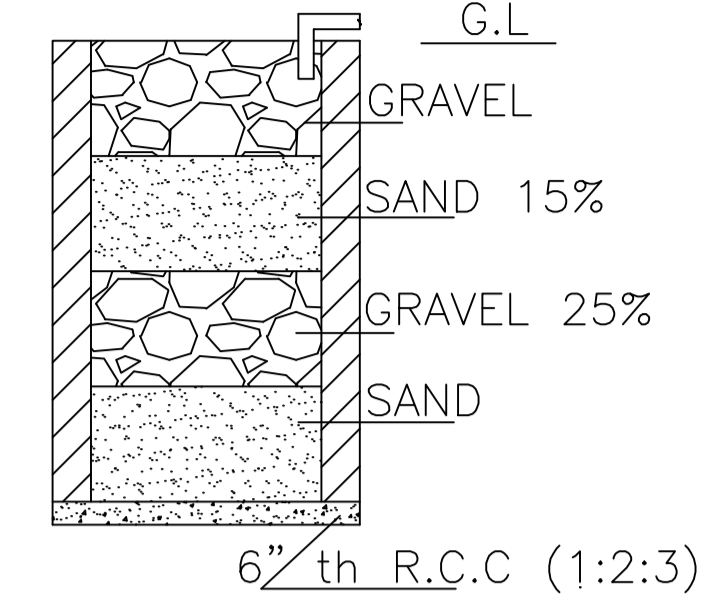

SECTION ON A - B

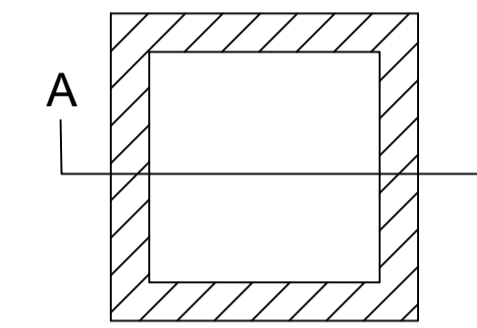

DETAILS DRAWING OF  
RAIN WATER HARVESTING

SCALE:- 1"=2'-0"

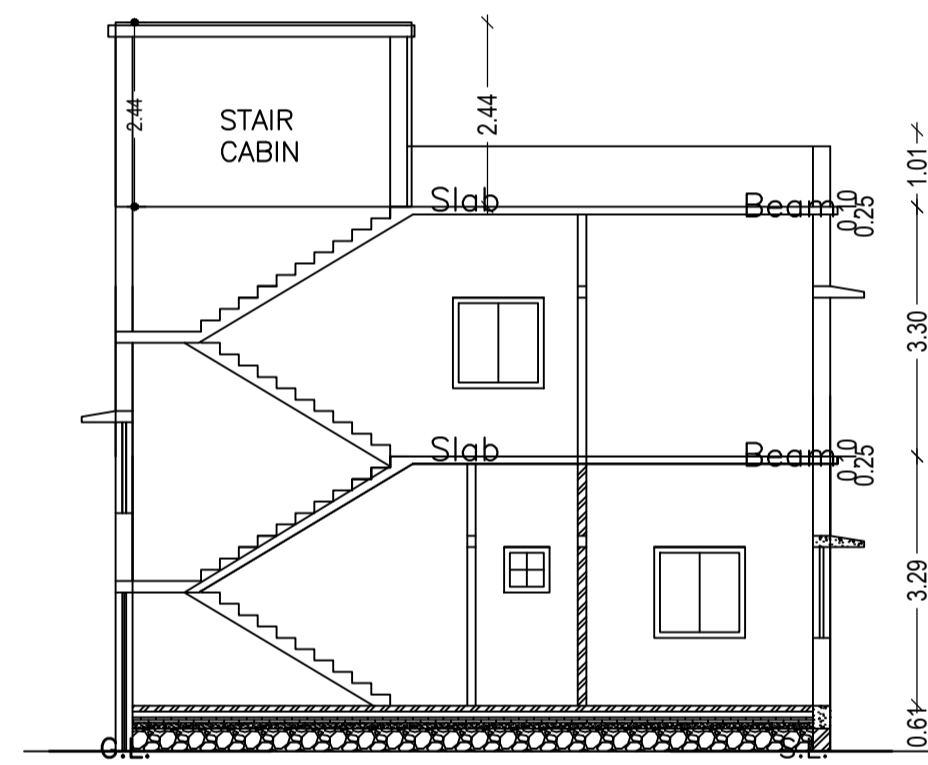

SECTION - XX'  
SCALE - 1" = 8'-0"

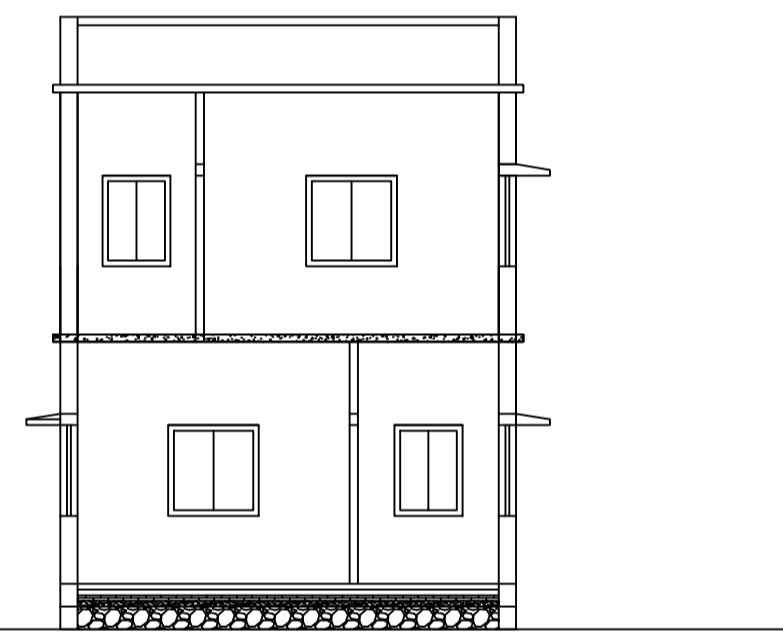

SECTION - YY'  
SCALE - 1" = 8'-0"

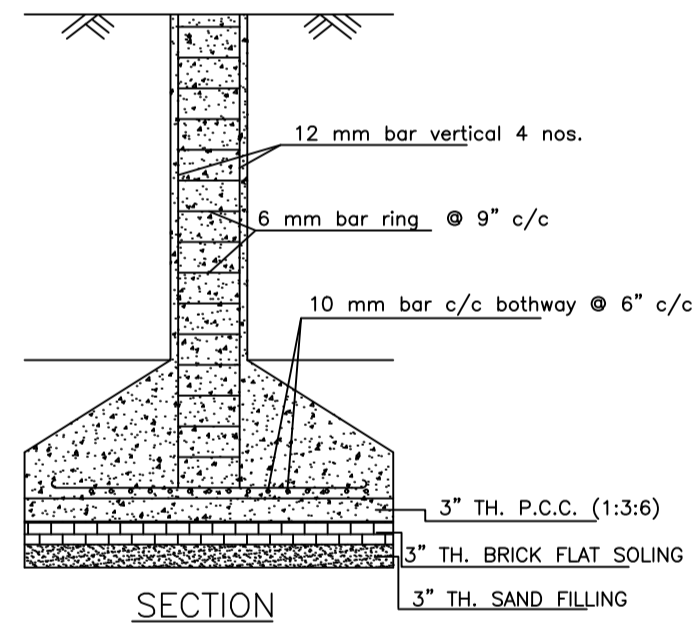

SECTION

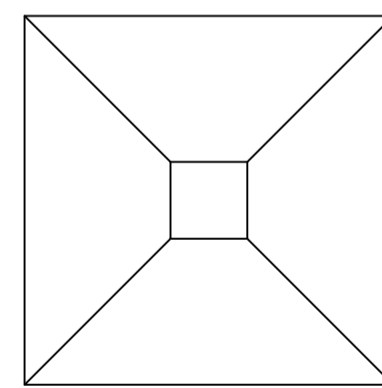

PLAN

DETAILS OF COLUMN FOUNDATION  
SCALE - 1" = 2'-0"

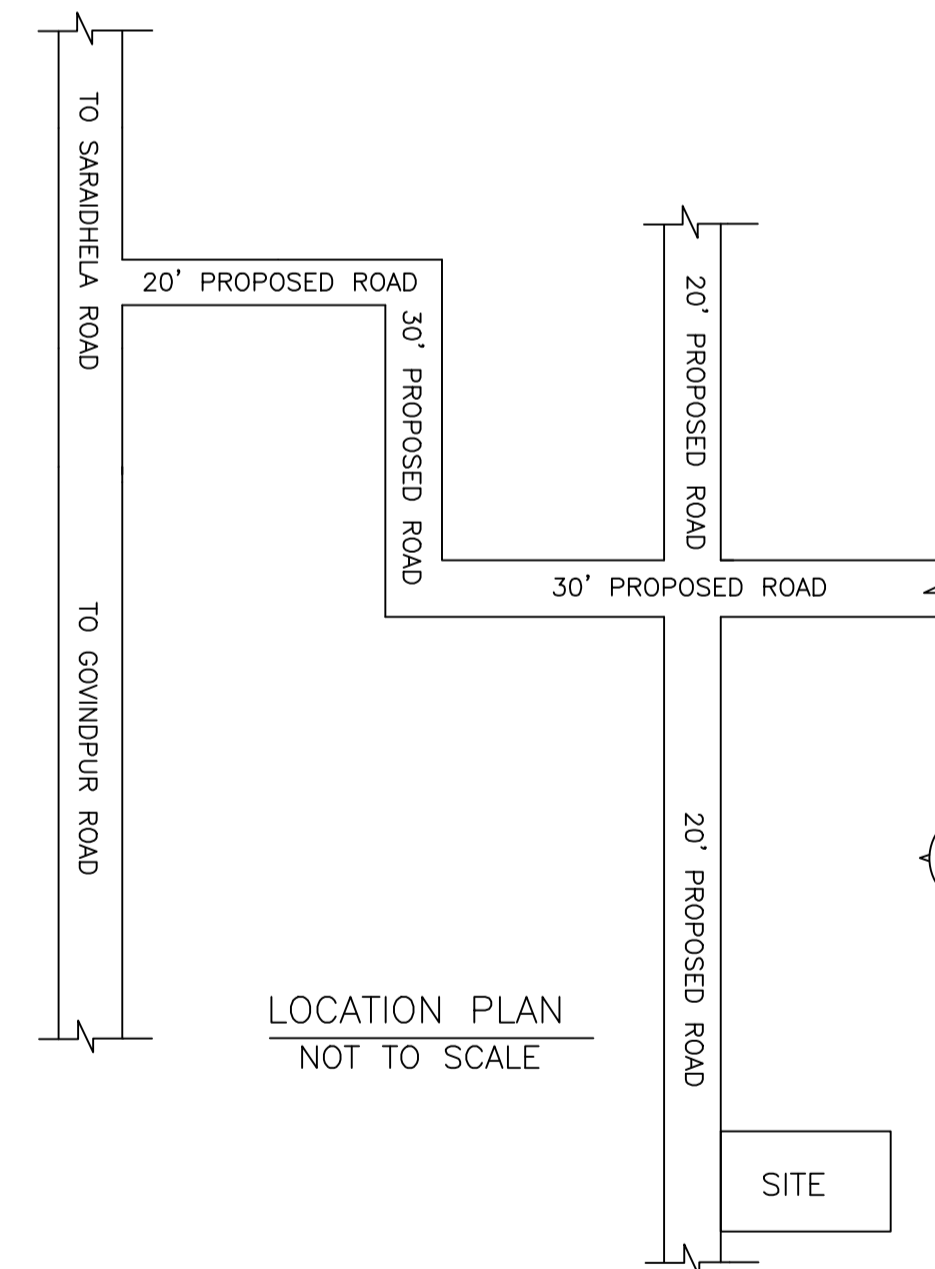

LOCATION PLAN  
NOT TO SCALE

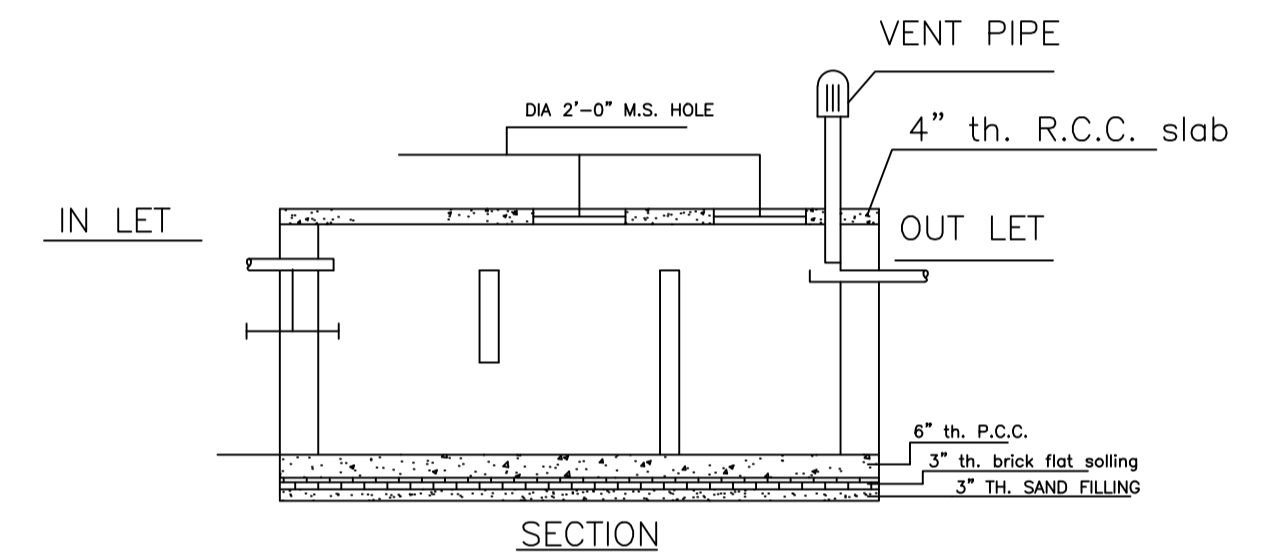

SECTION

DETAILS OF SEPTIC TANK  
SCALE - 1" = 4'-0"

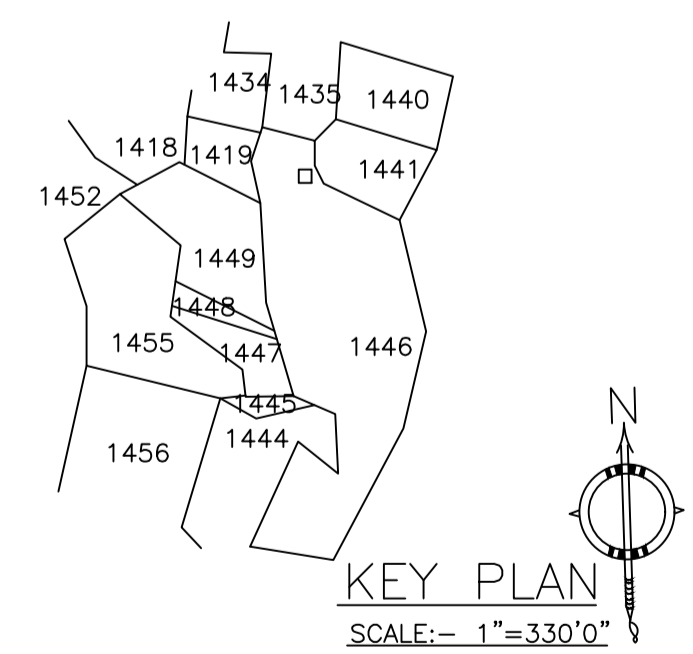

KEY PLAN  
SCALE:- 1"=330'0"

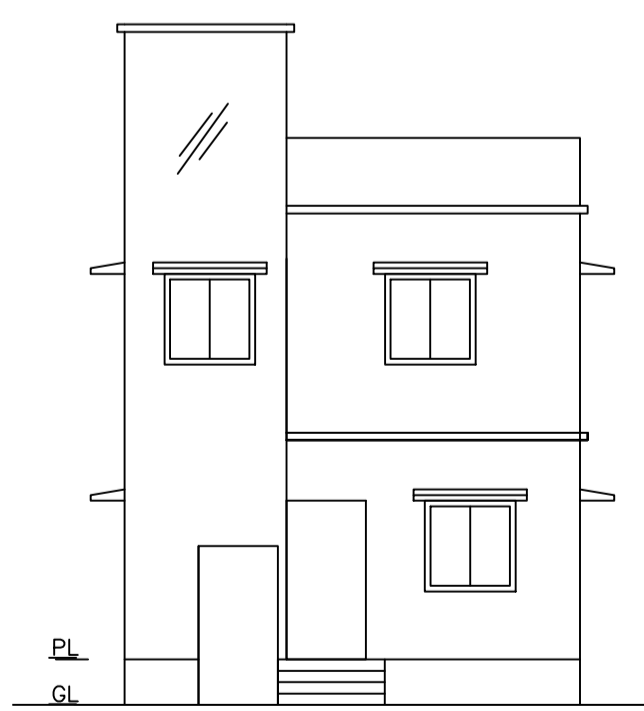

FRONT ELEVATION  
SCALE - 1" = 8'-0"

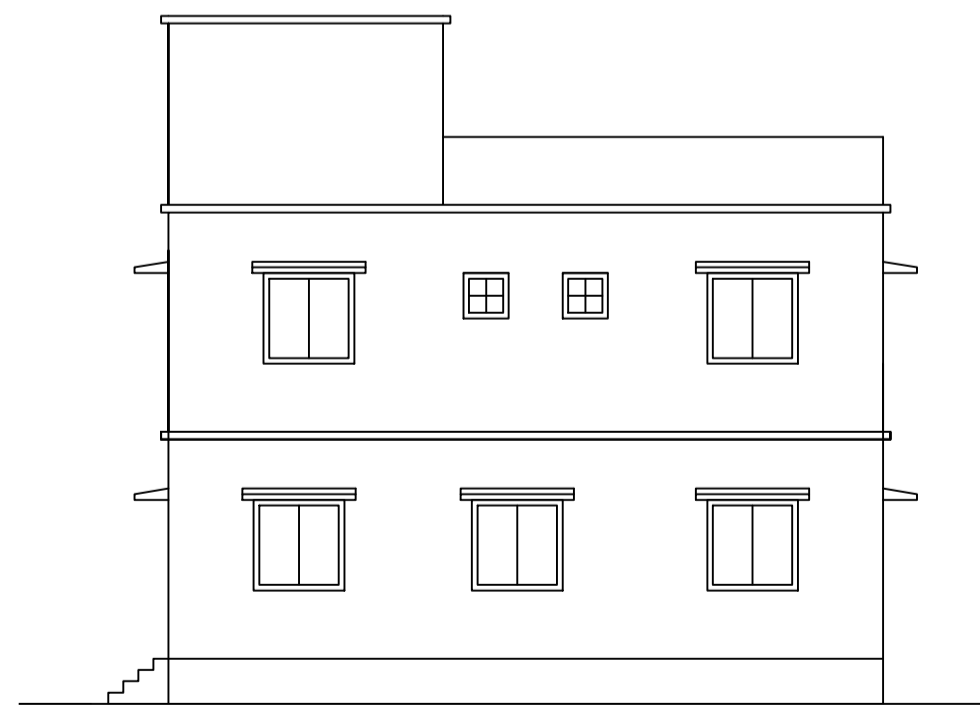

RIGHT SIDE ELEVATION  
SCALE - 1" = 8'-0"

LTP NAME AND SIGNATURE	STRUCTURAL ENG'S NAME AND SIGNATURE	BUILDER NAME AND SIGNATURE	DIGITAL SIGNATURE
RAM PRATAP SINGH MADA/ARC/0024/2019			