

Proposal Basic Information

Proposal File No.	MADA/BP/0264/2021
Owner Name	SMT. BIMLA DEVI
Khata No	old - 01,21 new - 101,102
Plot No	OLD- 452,626 NEW - 501, 718,720
Village Name	Sabalpur
Use	Residential
SubUse	Bungalow/ Dwelling / Non Apartment

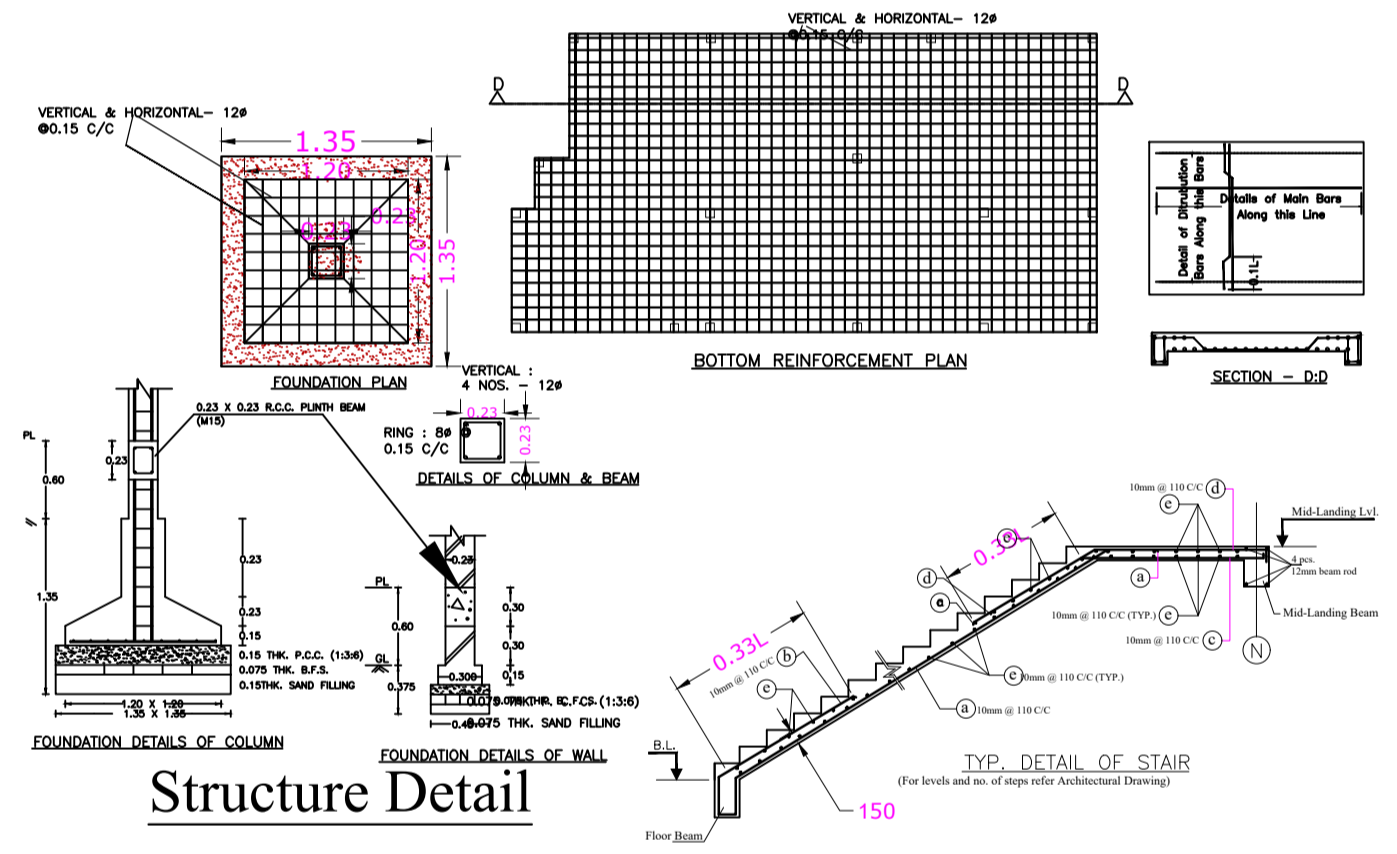
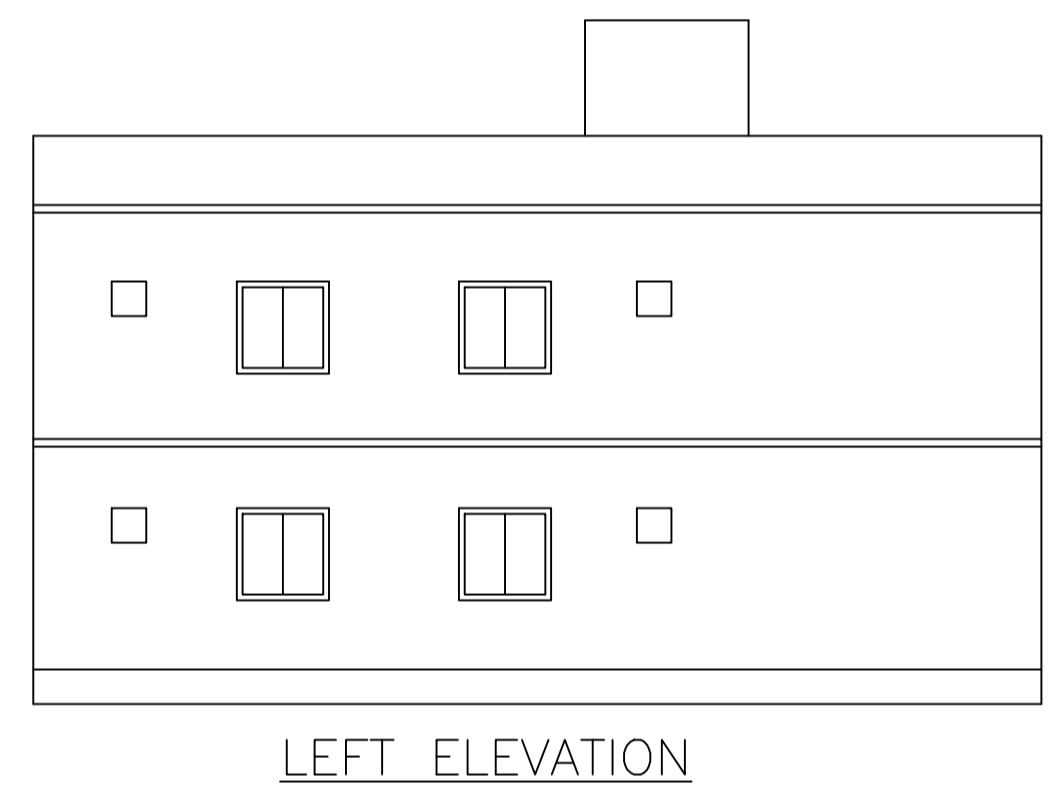
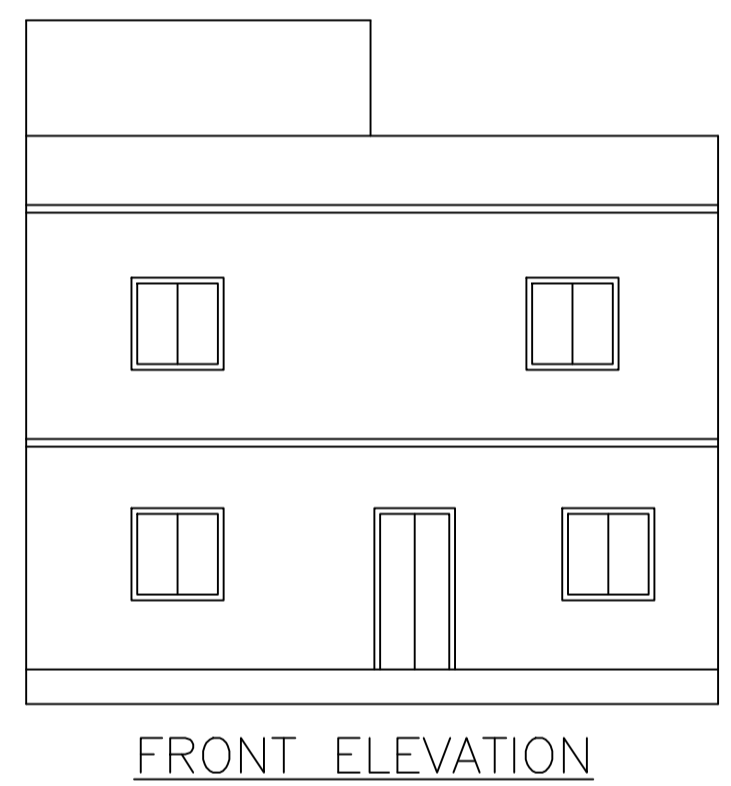
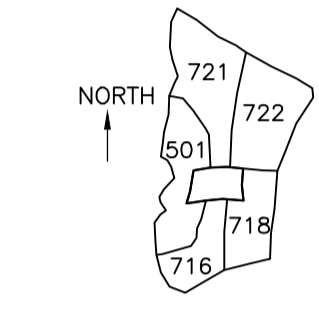
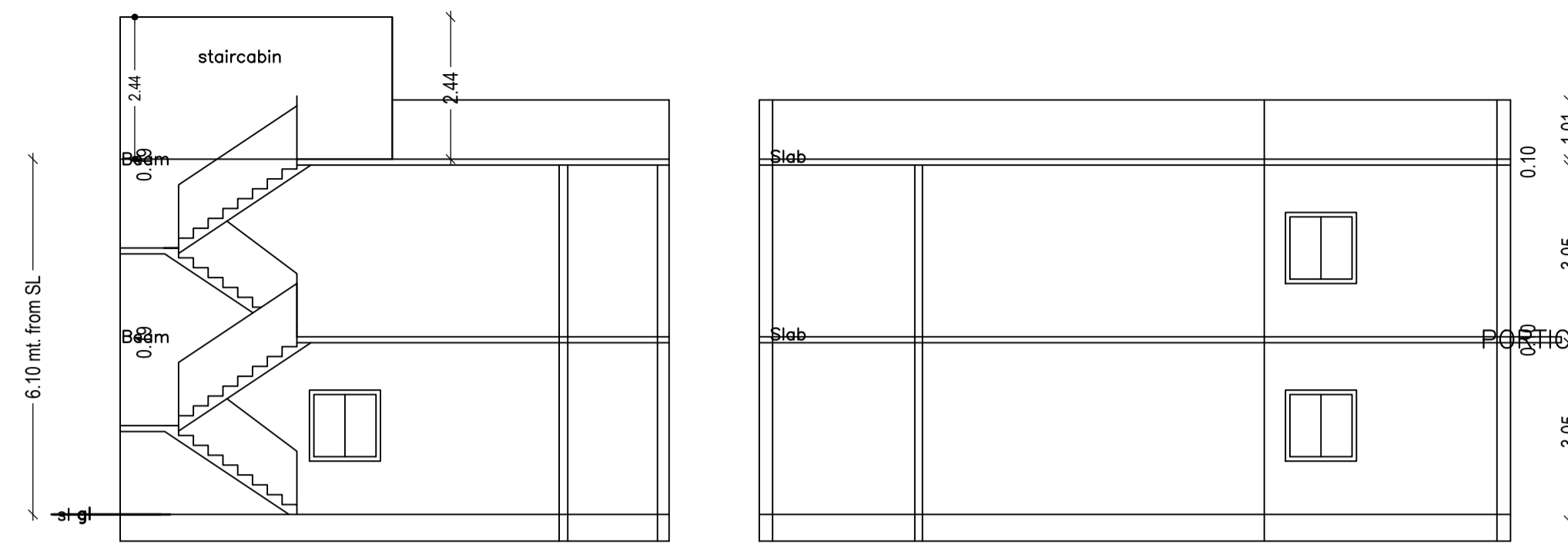
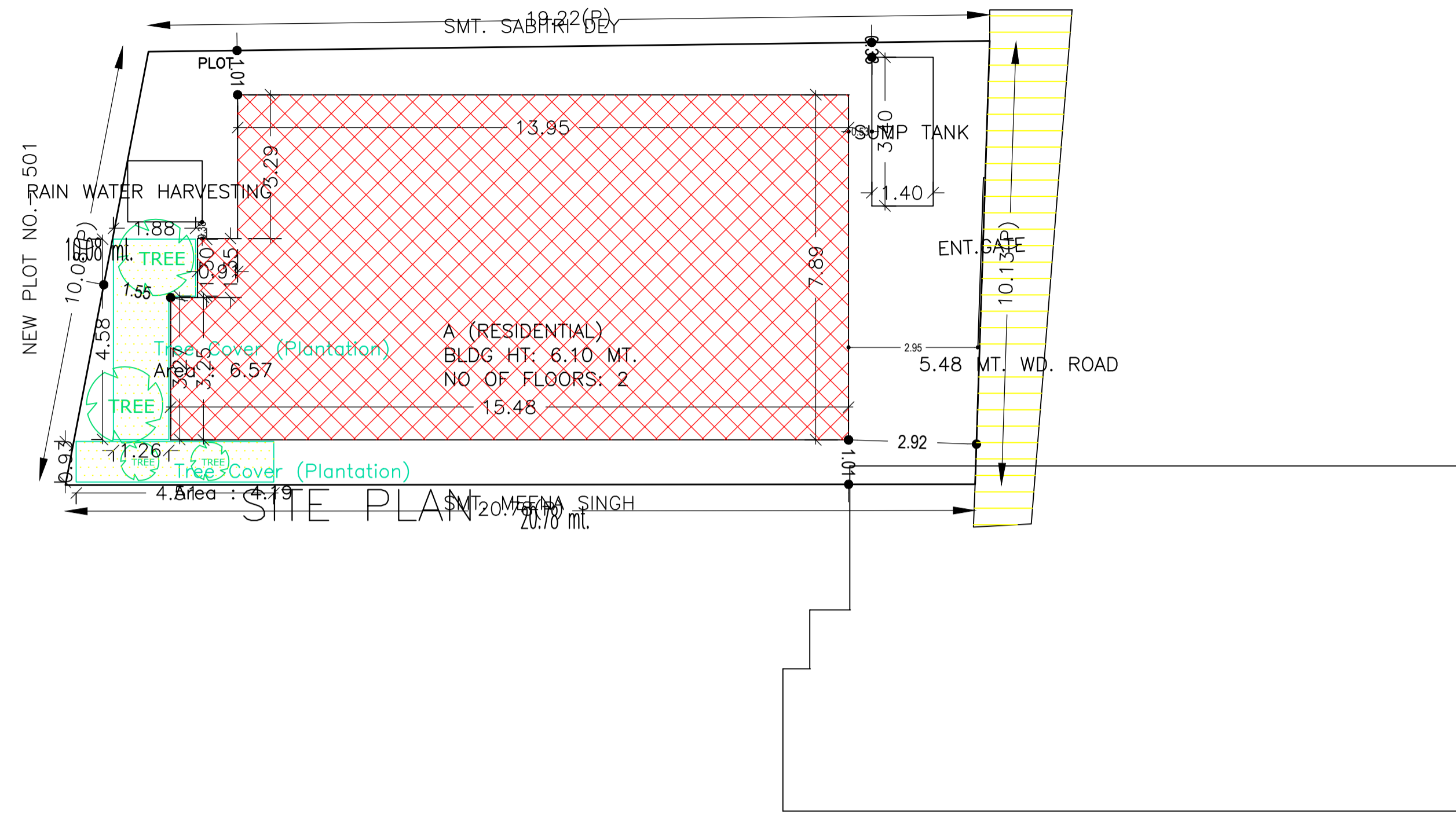

AREA STATEMENT MINERAL AREA DEVELOPMENT AUTHORITY	VERSION NO.: 1.0.61 VERSION DATE: 16/10/2020
PROJECT DETAIL:	
Region: JHARKHAND URBAN LOCAL BODIES	Plot Use: Residential
District: DHANBAD	Plot SubUse: Bungalow/ Dwelling / Non Apartment
Authority: MINERAL AREA DEVELOPMENT AUTHORITY	PlotNearby/ReligiousStructure: NA
Inward No: MADA/BP/0264/2021	Plot/SubPlot No: OLD- 452,626 NEW - 501, 718,720
Application Type: General Proposal	North: Plot No. - SMT SABITRI DEY
Project Type: Building Permission	South: Plot No. - SMT MEENA SINGH
Nature of Development: New	East: Road Width - 5.48
Location of Development Area: Old Area	West: Plot No. - NEW PLOT NO. - 501
AREA DETAILS:	
AREA OF PLOT (Minimum)	(A) 200.11 SQ.MT.
NET AREA OF PLOT(Gross Plot Area - Deduction from Gross Plot area)	(A-Deductions) 200.11
Deduction for Balance Plot Area(from Gross Plot Area)	
Common Plot Total	10.76
BALANCE AREA OF PLOT(Net Plot Area - Recreational/Amenity Space)	(A-Deductions) 189.35
PLOT AREA FOR COVERAGE(Net Plot Area)	(A-Deductions) 200.11
Plot Area for FAR (Net Plot Area + RoadWidening Area)	(A-Deductions) 200.11
COVERAGE CHECK	
Permissible Coverage area (70.00 %)	140.08
Proposed Coverage Area (58.10 %)	116.26
Total Prop. Coverage Area (58.1 %)	116.26
Balance coverage area (11.90 %)	23.82
FAR CHECK	
Perm. FAR Area (1.80)	360.20
Total Perm. FAR area	360.20
Residential FAR	232.51
Proposed FAR Area	232.51
Total Proposed FAR Area	232.51
Consumed FAR (Factor)	1.16
Balance FAR Area	127.69
BUILT UP AREA CHECK	
Total Proposed BuiltUp Area	232.52
ARCHITECT (Regd)	Kumud kanchan
ENGINEER (Regd)	
SUPERVISOR (Regd)	
OWNER (Regd)	SMT. BIMLA DEVI
DEVELOPMENT AUTHORITY LOCAL BODY	

COLOR INDEX	
PLOT BOUNDARY	Black
ABUTTING ROAD	Green
PROPOSED CONSTRUCTION	Red
COMMON PLOT	Yellow
ROAD WIDENING AREA	Orange
EXISTING (To be retained)	Blue
EXISTING (To be demolished)	Light Blue

Buildingwise Floor FAR Details				
Floor Name	Building Name A (RESIDENTIAL)		Total	
	Proposed Built Up Area (Sq.mt.)	Proposed FAR Area (Sq.mt.)	Total Proposed Built Up Area (Sq.mt.)	Total FAR Area (Sq.mt.)
Ground Floor	116.26	116.26	116.26	116.26
First Floor	116.26	116.26	116.26	116.26
Terrace Floor	0.00	0.00	0.00	0.00
Total :	232.52	232.52	232.52	232.52

Building USE/SUBUSE Details			
Building Name	Building Use	Building SubUse	Building Structure
A (RESIDENTIAL)	Residential	Bungalow/ Dwelling / Non Apartment	Non-Highrise

UnitBUA Table for Building :A (RESIDENTIAL)						
FLOOR	Name	UnitBUA Type	UnitBUA Area	Carpet Area	No. of Rooms	No. of Tenement
FIRST FLOOR PLAN	SPLIT 1	FLAT	0.00	0.00	11	0
GROUND FLOOR PLAN	SPLIT 1	FLAT	232.51	232.51	11	1
Total:	-	-	232.51	232.51	22	1

FAR & Tenement Details (Table 4c-1)						
Building	No. of Same Bldg	Total Built Up Area (Sq.mt.)	Proposed FAR Area (Sq.mt.) Resi.	Total FAR Area (Sq.mt.)	Total Consumed Additional FAR Area (Sq.mt.)	Tnmt (No.)
A (RESIDENTIAL)	1	232.52	232.52	232.52	232.52	01
Grand Total :	1	232.52	232.52	232.52	232.52	01

SCHEDULE OF DOOR:

BUILDING NAME	NAME	LENGTH	HEIGHT	NOS
A (RESIDENTIAL)	D	0.90	2.10	17
A (RESIDENTIAL)	D1	1.06	2.10	01

SCHEDULE OF WINDOW/VENTILATION:

BUILDING NAME	NAME	LENGTH	HEIGHT	NOS
A (RESIDENTIAL)	V	0.80	1.20	07
A (RESIDENTIAL)	W	1.50	1.20	16

Building :A (RESIDENTIAL)

Floor Name	Total Built Up Area (Sq.mt.)	Proposed FAR Area (Sq.mt.) Resi.	Total FAR Area (Sq.mt.)	Total Consumed Additional FAR Area (Sq.mt.)	Tnmt (No.)
Ground Floor	116.26	116.26	116.26	116.26	01
First Floor	116.26	116.26	116.26	116.26	00
Terrace Floor	0.00	0.00	0.00	0.00	00
Total :	232.52	232.52	232.52	232.52	01
Total Number of Same Buildings	1				
Total :	232.52	232.52	232.52	232.52	01

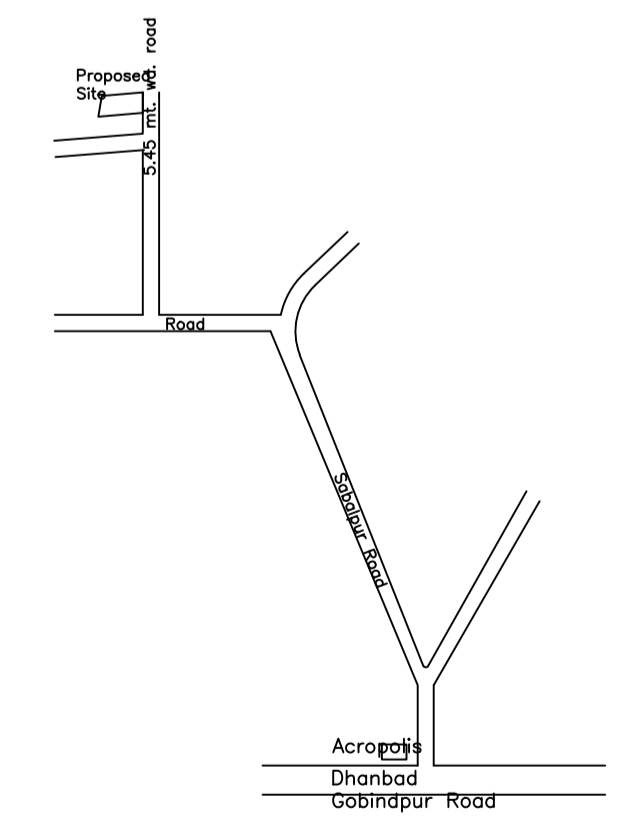
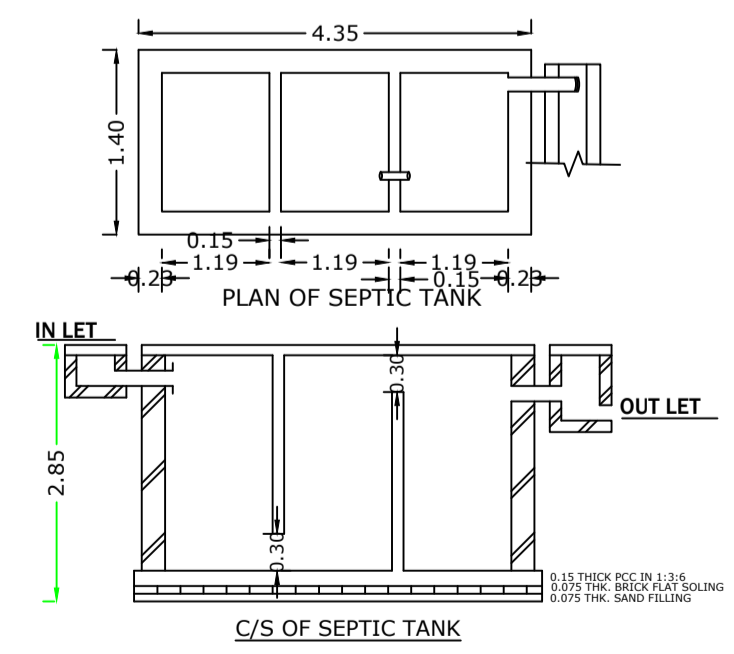
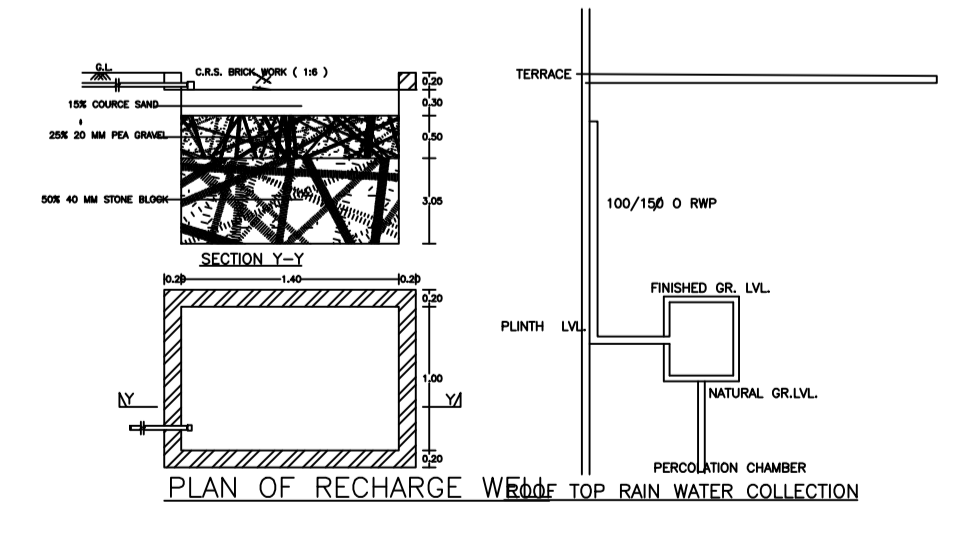

Proposal Basic Information	
Proposal File No.	MADA/BP/0264/2021
Owner Name	SMT. BIMLA DEVI
Khata No	old - 01,21 new - 101,102
Plot No	OLD- 452,626 NEW - 501, 718,720
Village Name	Sabalpur
Use	Residential
SubUse	Bungalow/ Dwelling / Non Apartment

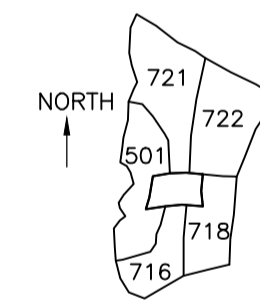
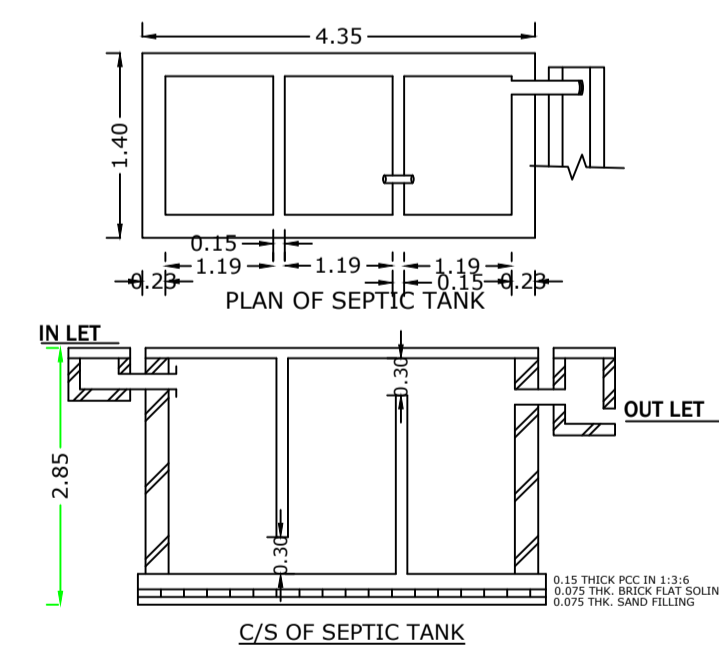
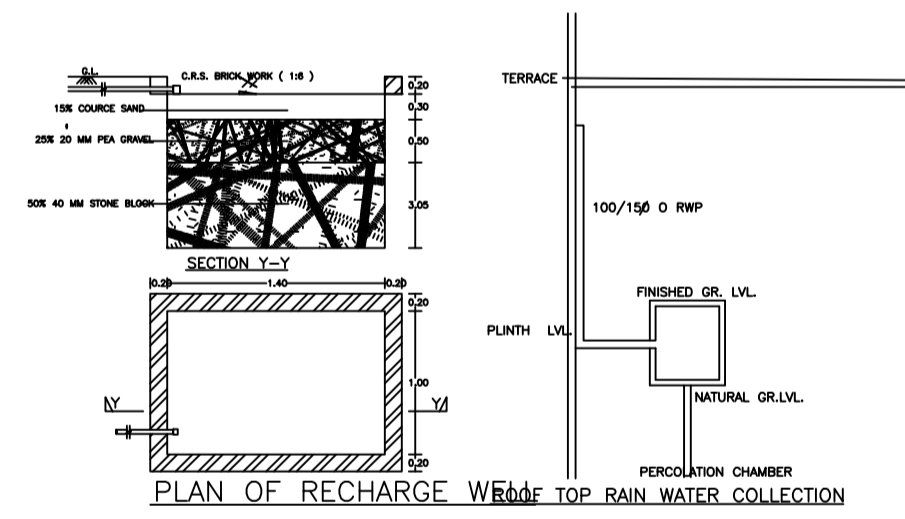
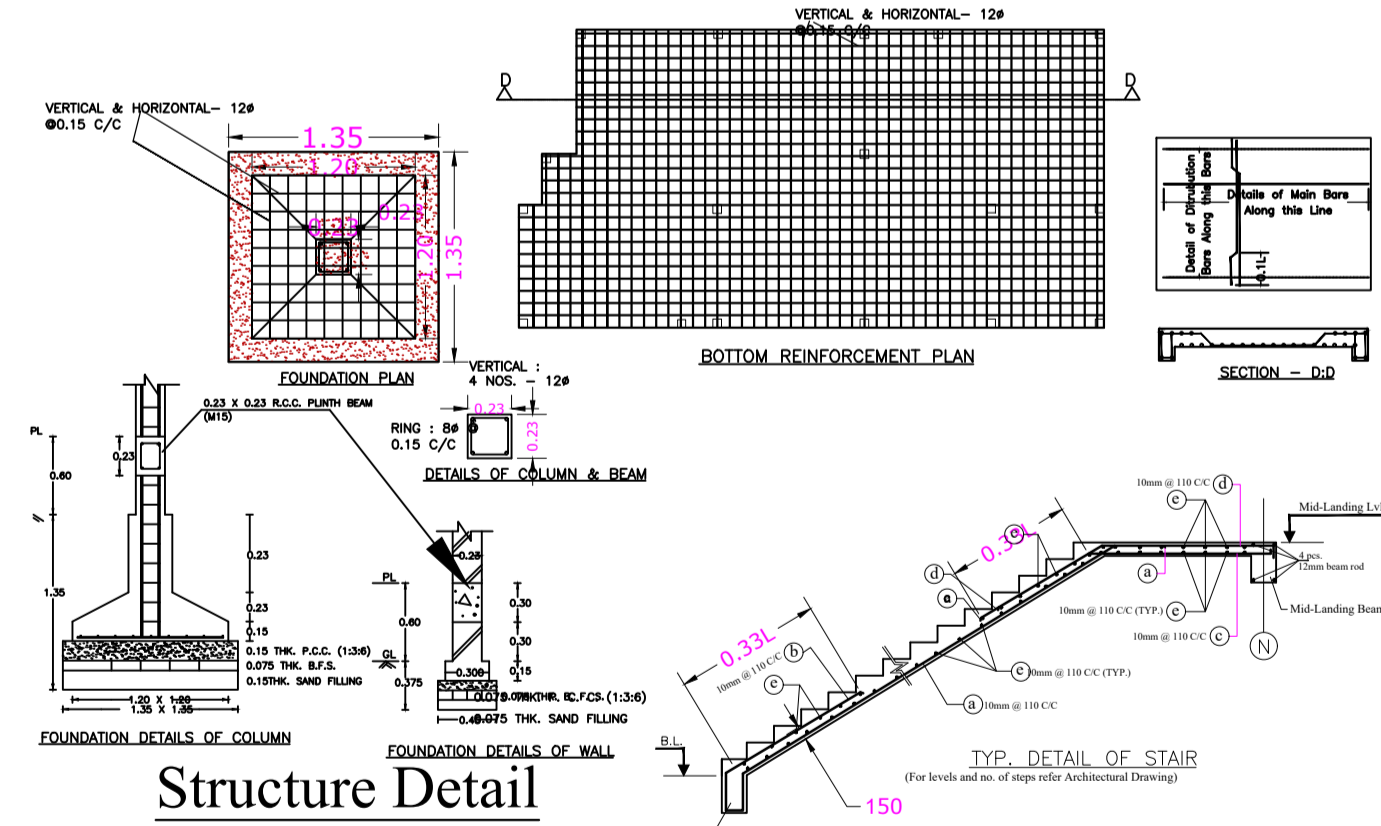
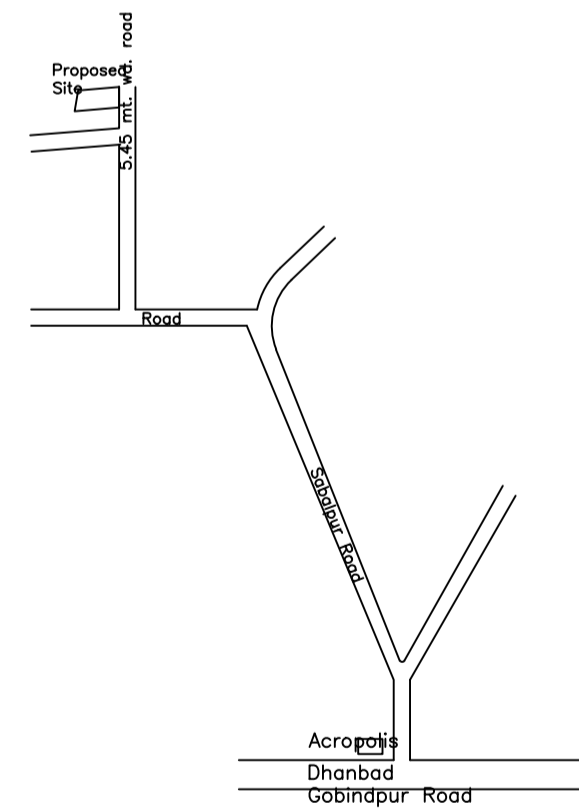
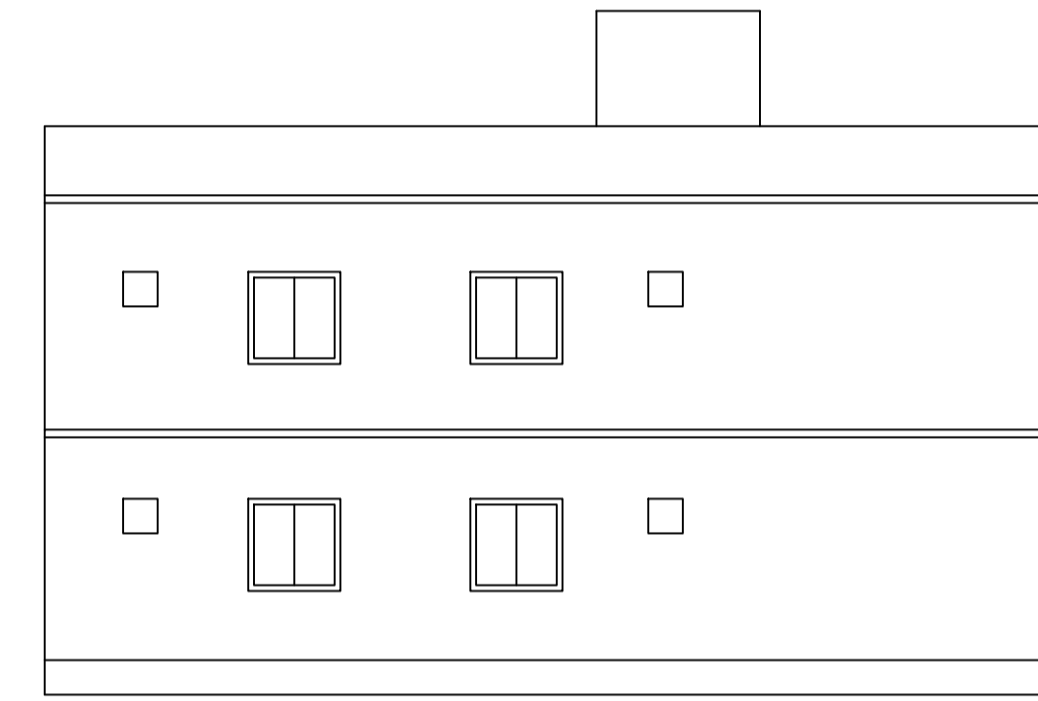
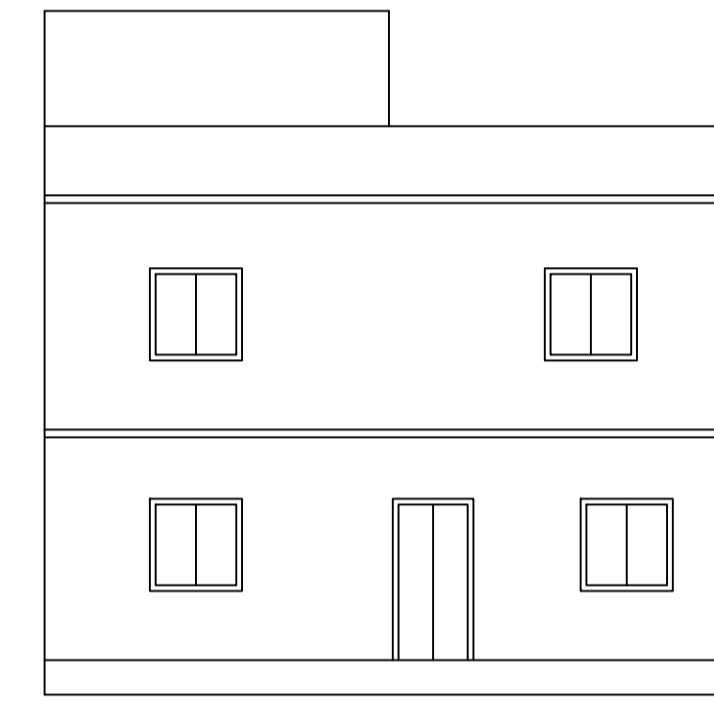
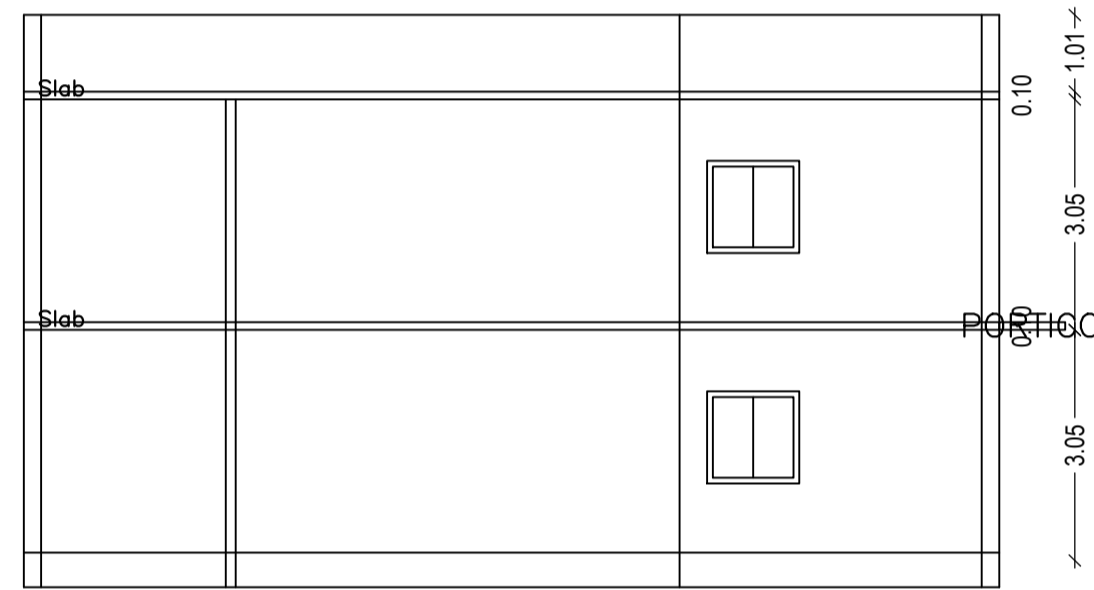
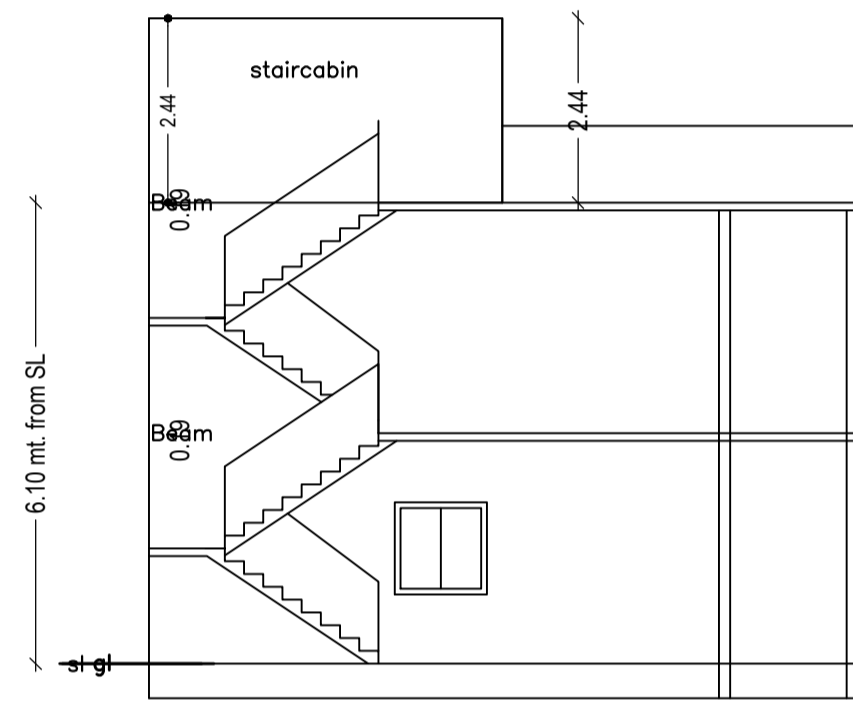
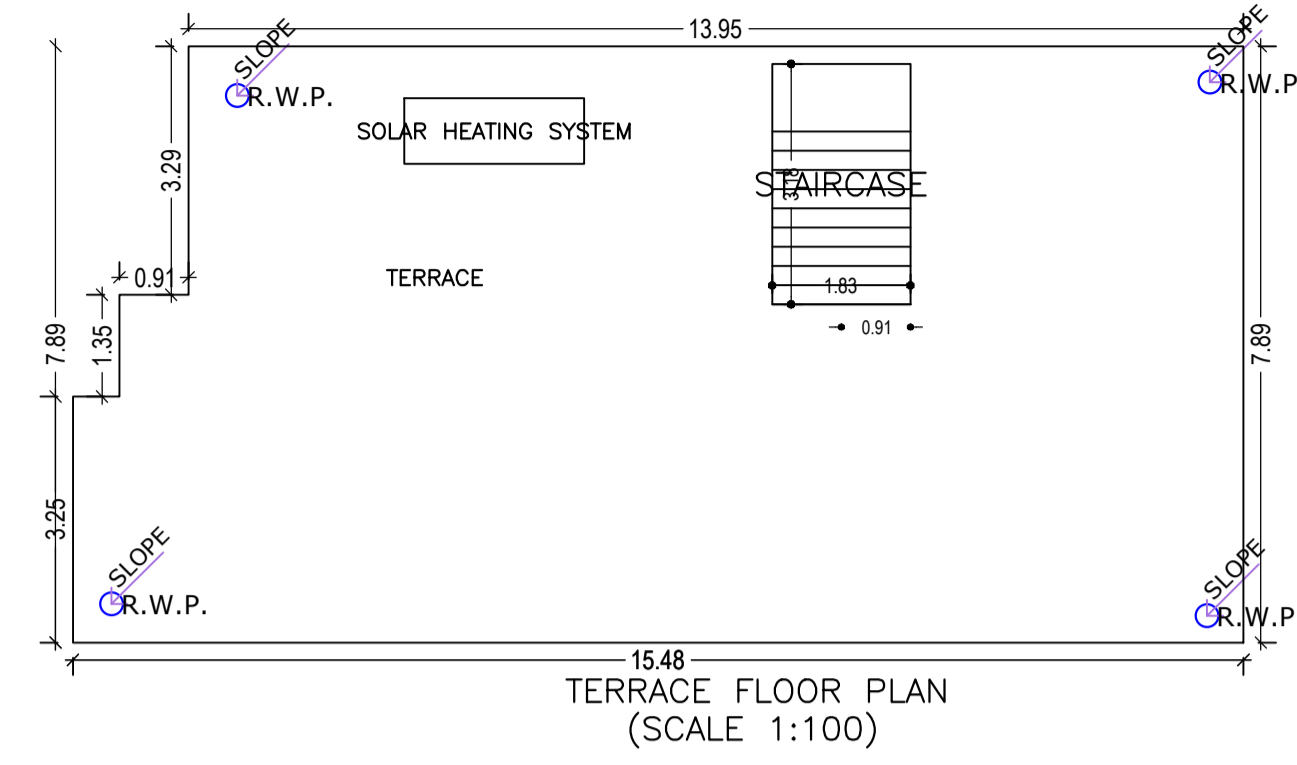
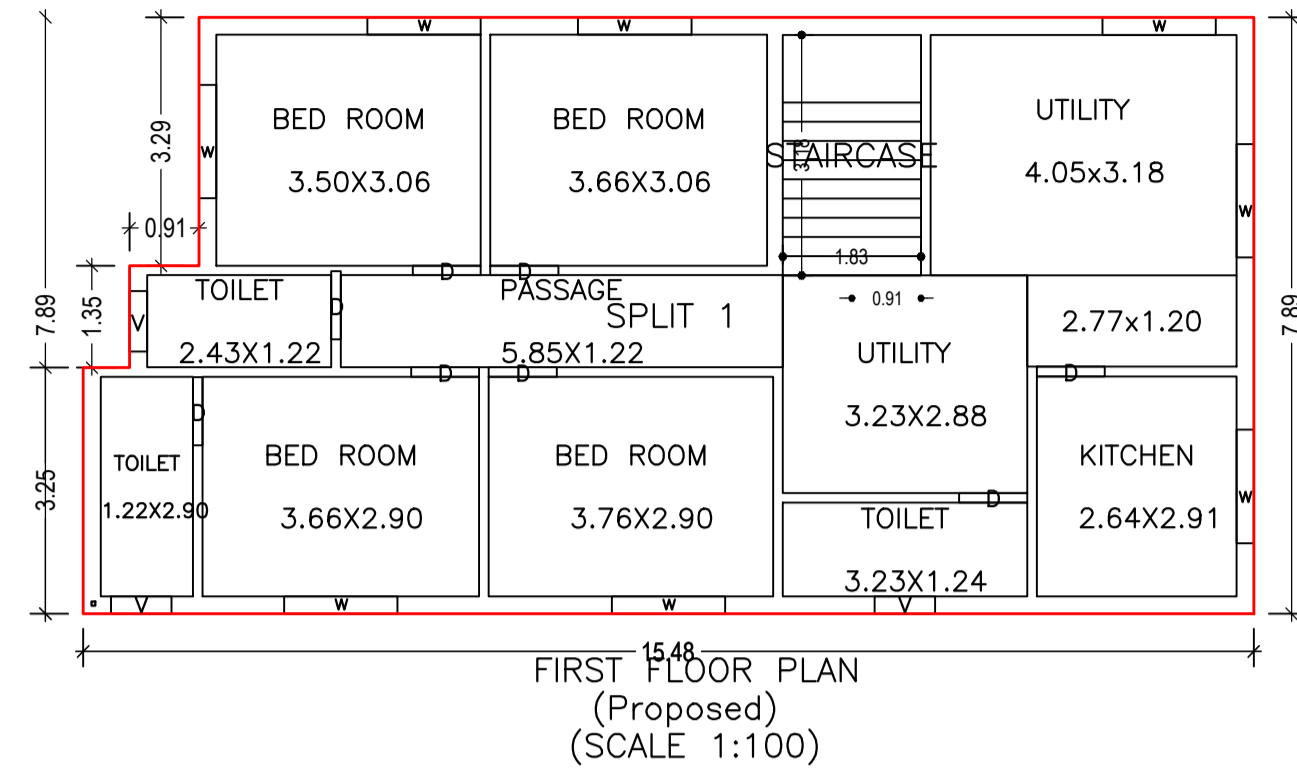
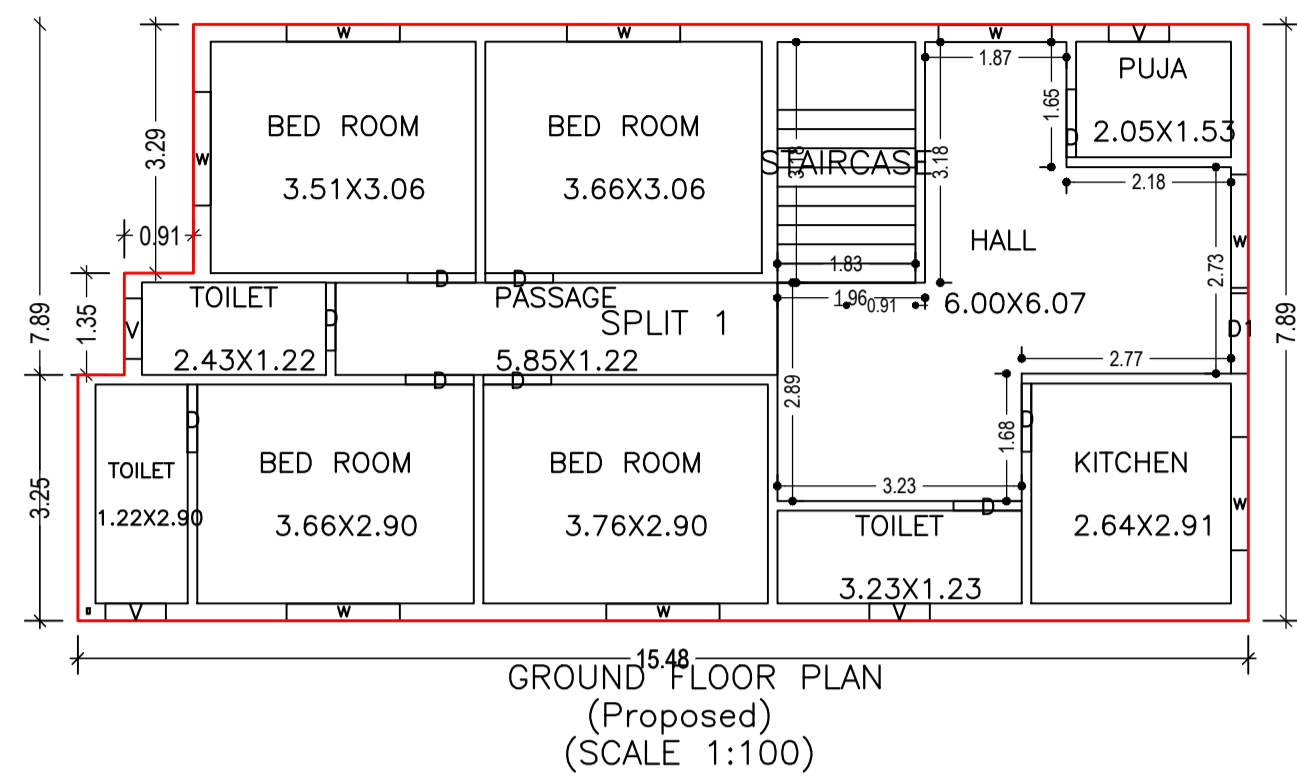

LTP NAME AND SIGNATURE	STRUCTURAL ENG'S NAME AND SIGNATURE	BUILDER NAME AND SIGNATURE	DIGITAL SIGNATURE
Kumud kanchan MADA/ARC/001/02019			