

Proposal Basic Information

Proposal File No.	MADA/BP/0357/2021
Owner Name	M/S. TECHNO CULTURE BUILDINGS CENTRE PVT. LTD Represent By its DirectorSRI DINESH KUMAR TIWARI
Khata No	29,70,NEW-78,79
Plot No	654,645,646,647,648,649,650,651,652,655,657,672,681,NEW-1468,1471,1475,1476,1477,1478,1479,1482
Village Name	Jalgora
Use	Residential
SubUse	Bungalow/ Dwelling / Non Apartment

UnitBUA Table for Building :A (SRI DINESH KUMAR TIWARI)

FLOOR	Name	UnitBUA Type	UnitBUA Area	Carpet Area	No. of Rooms	No. of Tenement
GROUND FLOOR PLAN	SPLIT A	FLAT	1151.36	1151.31	12	1
TYPICAL - 1, 2, 3 FLOOR PLAN	SPLIT A	FLAT	0.00	0.00	28	0
Total:	-	-	1151.36	1151.31	96	1

SCHEDULE OF DOOR:

BUILDING NAME	NAME	LENGTH	HEIGHT	NOS
A (SRI DINESH KUMAR TIWARI)	D	0.58	2.10	03
A (SRI DINESH KUMAR TIWARI)	D	0.76	2.10	28
A (SRI DINESH KUMAR TIWARI)	D	0.94	2.10	09
A (SRI DINESH KUMAR TIWARI)	D	0.99	2.10	24
A (SRI DINESH KUMAR TIWARI)	D	1.07	2.10	32

SCHEDULE OF WINDOW/VENTILATION:

BUILDING NAME	NAME	LENGTH	HEIGHT	NOS
A (SRI DINESH KUMAR TIWARI)	W	0.67	1.20	03
A (SRI DINESH KUMAR TIWARI)	W	0.73	1.20	02
A (SRI DINESH KUMAR TIWARI)	W	0.75	1.20	03
A (SRI DINESH KUMAR TIWARI)	W	0.77	1.20	01
A (SRI DINESH KUMAR TIWARI)	W	0.79	1.20	03
A (SRI DINESH KUMAR TIWARI)	W	0.81	1.20	01
A (SRI DINESH KUMAR TIWARI)	W	0.89	1.20	03
A (SRI DINESH KUMAR TIWARI)	W	0.94	1.20	03
A (SRI DINESH KUMAR TIWARI)	W	1.06	1.20	03
A (SRI DINESH KUMAR TIWARI)	W	1.10	1.20	03
A (SRI DINESH KUMAR TIWARI)	W	1.11	1.20	03
A (SRI DINESH KUMAR TIWARI)	W	1.15	1.20	03
A (SRI DINESH KUMAR TIWARI)	W	1.19	1.20	01
A (SRI DINESH KUMAR TIWARI)	W	1.20	1.20	03
A (SRI DINESH KUMAR TIWARI)	W	1.23	1.20	03
A (SRI DINESH KUMAR TIWARI)	W	1.30	1.20	03
A (SRI DINESH KUMAR TIWARI)	W	1.35	1.20	01
A (SRI DINESH KUMAR TIWARI)	W	1.37	1.20	01
A (SRI DINESH KUMAR TIWARI)	W	1.38	1.20	02
A (SRI DINESH KUMAR TIWARI)	W	1.43	1.20	03
A (SRI DINESH KUMAR TIWARI)	W	1.44	1.20	01
A (SRI DINESH KUMAR TIWARI)	W	1.51	1.20	01
A (SRI DINESH KUMAR TIWARI)	W	1.54	1.20	03
A (SRI DINESH KUMAR TIWARI)	W	1.57	1.20	03
A (SRI DINESH KUMAR TIWARI)	W	1.60	1.20	04
A (SRI DINESH KUMAR TIWARI)	W	1.65	1.20	03
A (SRI DINESH KUMAR TIWARI)	W	1.68	1.20	03
A (SRI DINESH KUMAR TIWARI)	W	1.85	1.20	03
A (SRI DINESH KUMAR TIWARI)	W	1.93	1.20	03
A (SRI DINESH KUMAR TIWARI)	W	1.96	1.20	03
A (SRI DINESH KUMAR TIWARI)	W	1.97	1.20	03
A (SRI DINESH KUMAR TIWARI)	W	2.03	1.20	03
A (SRI DINESH KUMAR TIWARI)	W	2.07	1.20	01
A (SRI DINESH KUMAR TIWARI)	W	2.08	1.20	04
A (SRI DINESH KUMAR TIWARI)	W	2.10	1.20	03
A (SRI DINESH KUMAR TIWARI)	W	2.19	1.20	03
A (SRI DINESH KUMAR TIWARI)	W	2.77	1.20	03

AREA STATEMENT MINERAL	VERSION NO.:
AREA DEVELOPMENT AUTHORITY	1.0.69
REGION: JHARKHAND URBAN LOCAL BODIES	VERSION DATE: 16/10/2020
Plot Use: Residential	
Plot SubUse: Bungalow/ Dwelling / Non Apartment	
PlotNearbyReligiousStructure: NA	
Plot/SubPlot No: 654,645,646,647,648,649,650,651,652,655,657,672,681,NEW-1468,1471,1475,1476,1477,1478,1479,1482	
North: Road Width - 6.10	
South: Road Width - 6.10	
East: Road Width - 6.10	
West: Road Width - 6.10	
AREA DETAILS:	SQ.MT.
NET AREA OF PLOT (Minimum)	640.94
NET AREA OF PLOT (Gross Plot Area - Deduction from Gross Plot Area)	640.94
Deduction for Balance Plot Area (from Gross Plot Area)	
Common Plot	159.21
Total	159.21
BALANCE AREA OF PLOT (Net Plot Area - Recreational/Amenity space)	481.72
PLOT AREA FOR COVERAGE (Net Plot Area)	640.94
Plot Area for FAR (Net Plot Area + Road Widening Area)	640.94
COVERAGE CHECK	
Permissible Coverage area ( 60.00 % )	384.56
Proposed Coverage Area ( 44.91 % )	287.84
Total Prop. Coverage Area ( 44.91 % )	287.84
Balance coverage area ( 15.09 % )	96.72
FAR CHECK	
Perm. FAR Area ( 2.500 )	1602.35
Total Perm. FAR area	1602.35
Residential FAR	1151.36
Proposed FAR Area	1151.36
Total Proposed FAR Area	1151.36
Consumed FAR (Factor)	1.80
Balance FAR Area	450.99
BUILT UP AREA CHECK	
Total Proposed BuiltUp Area	1151.36
ARCHITECT (Regd)	RAJEEV RANJAN SINGH
ENGINEER (Regd)	
SUPERVISOR (Regd)	
OWNER (Regd)	M/S. TECHNO CULTURE BUILDINGS CENTRE PVT. LTD Represent By its DirectorSRI DINESH KUMAR TIWARI
DEVELOPMENT AUTHORITY	LOCAL BODY

COLOR INDEX	
PLOT BOUNDARY	Black
ABUTTING ROAD	Green
PROPOSED CONSTRUCTION	Red
COMMON PLOT	Yellow
ROAD WIDENING AREA	Blue
EXISTING (To be retained)	Light Blue
EXISTING (To be demolished)	Light Green

Buildingwise Floor FAR Details

Floor Name	Building Name		Total	
	Proposed Built Up Area (Sq.mt.)	Proposed FAR Area (Sq.mt.)	Total Proposed Built Up Area (Sq.mt.)	Total FAR Area (Sq.mt.)
Ground Floor	287.84	287.84	287.84	287.84
First Floor	287.84	287.84	287.84	287.84
Second Floor	287.84	287.84	287.84	287.84
Third Floor	287.84	287.84	287.84	287.84
Terrace Floor	0.00	0.00	0.00	0.00
Total :	1151.36	1151.36	1151.36	1151.36

Building USE/SUBUSE Details

Building Name	Building Use	Building SubUse	Building Structure
A (SRI DINESH KUMAR TIWARI)	Residential	Bungalow/ Dwelling / Non Apartment	Non-Highrise

FAR & Tenement Details (Table 4c-1)

Building	No. of Same Bldg	Total Built Up Area (Sq.mt.)	Proposed FAR Area (Sq.mt.)	Total FAR Area (Sq.mt.)	Total Consumed Additional FAR Area (Sq.mt.)	Tnmt (No.)
A (SRI DINESH KUMAR TIWARI)	1	1151.36	1151.36	1151.36	1151.36	01
Grand Total :	1	1151.36	1151.36	1151.36	1151.36	01

Building :A (SRI DINESH KUMAR TIWARI)

Floor Name	Total Built Up Area (Sq.mt.)	Proposed FAR Area (Sq.mt.)	Total FAR Area (Sq.mt.)	Total Consumed Additional FAR Area (Sq.mt.)	Tnmt (No.)
Ground Floor	287.84	287.84	287.84	287.84	01
First Floor	287.84	287.84	287.84	287.84	00
Second Floor	287.84	287.84	287.84	287.84	00
Third Floor	287.84	287.84	287.84	287.84	00
Terrace Floor	0.00	0.00	0.00	0.00	00
Total :	1151.36	1151.36	1151.36	1151.36	01
Total Number of Same Buildings :	1				
Total :	1151.36	1151.36	1151.36	1151.36	01

LTP NAME AND SIGNATURE	STRUCTURAL ENG'S NAME AND SIGNATURE	BUILDER NAME AND SIGNATURE	DIGITAL SIGNATURE
RAJEEV RANJAN SINGH MADA/ENG/004/2019			

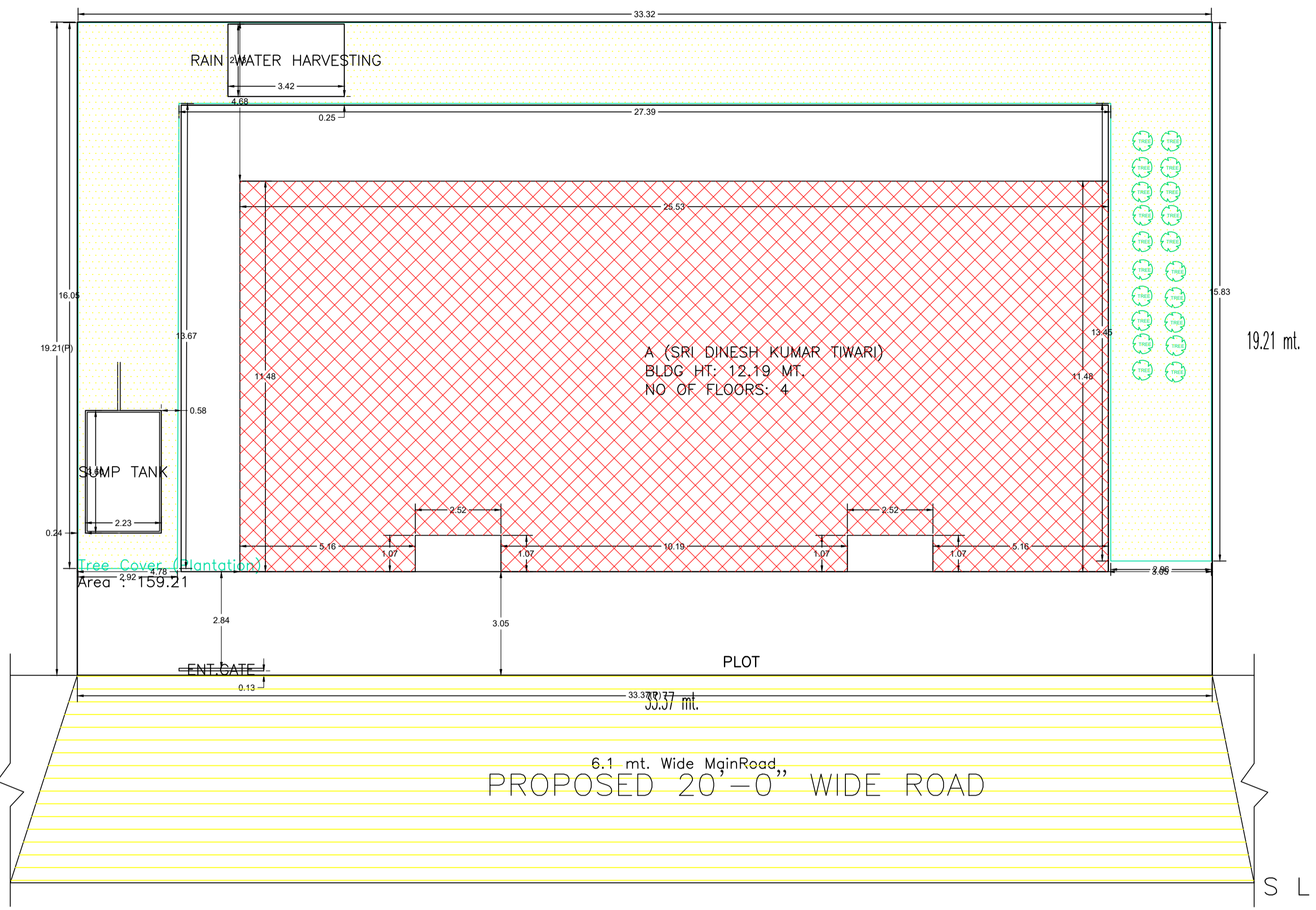

SITE PLAN  
SCALE:-1:100  
SITE

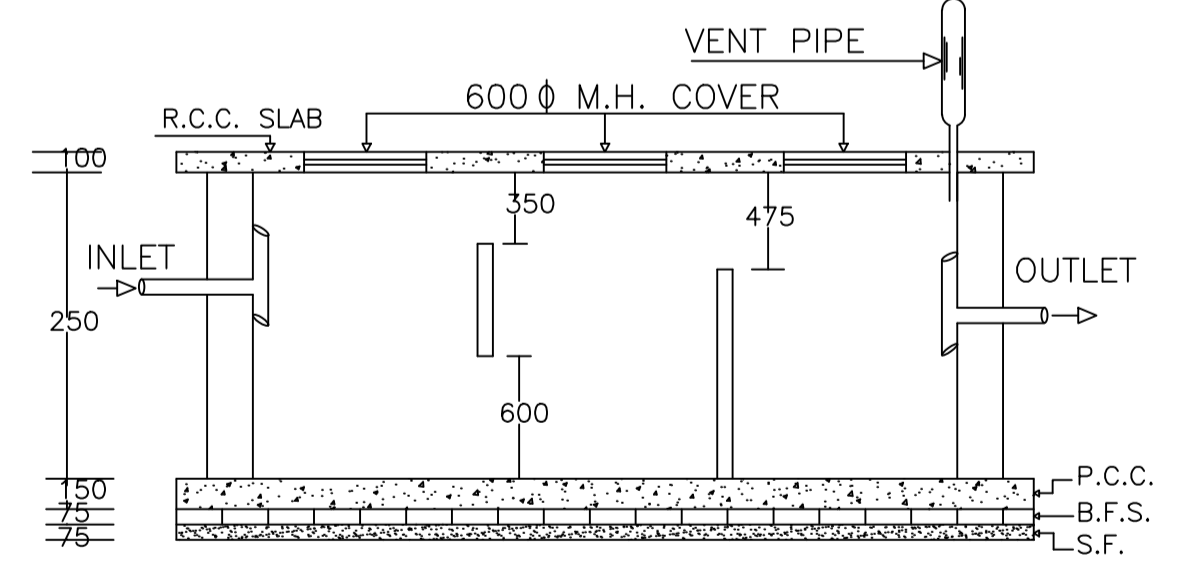

PLAN OF SEPTIC TANK

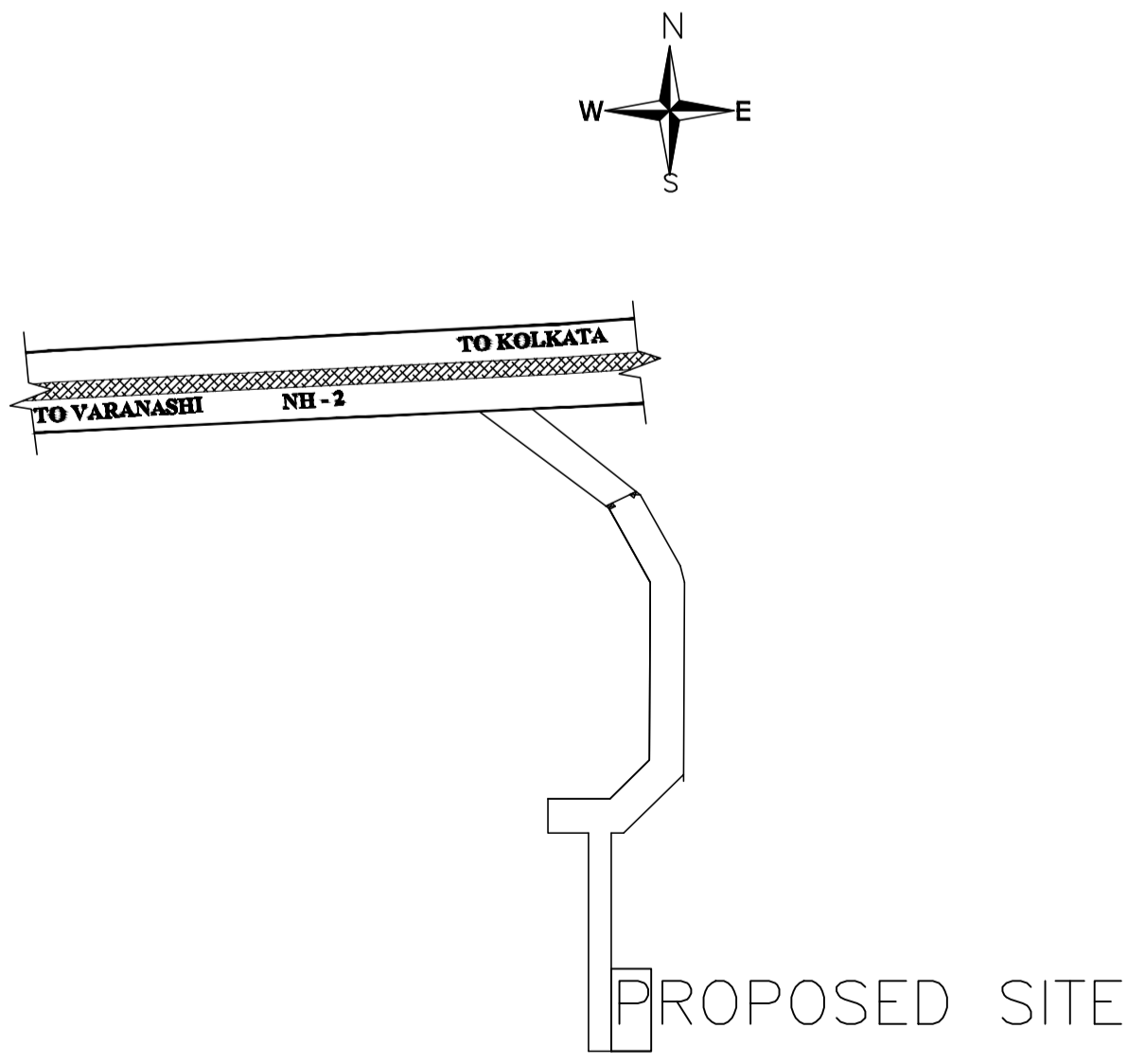

PROPOSED SITE

Proposal Basic Information	
Proposal File No.	MADA/BP/0357/2021
Owner Name	M/S. TECHNO CULTURE BUILDINGS CENTRE PVT. LTD Represent by its Director SRI DINESH KUMAR TIWARI
Khata No	29,70,NEW-78,79
Plot No	694,645,646,647,648,649,650,651,652,655,657,672,681,NEW-1468,1471,1475,1476,1477,1478,1479,1482
Village Name	Jalgora
Use	Residential
SubUse	Bungalow/ Dwelling / Non Apartment

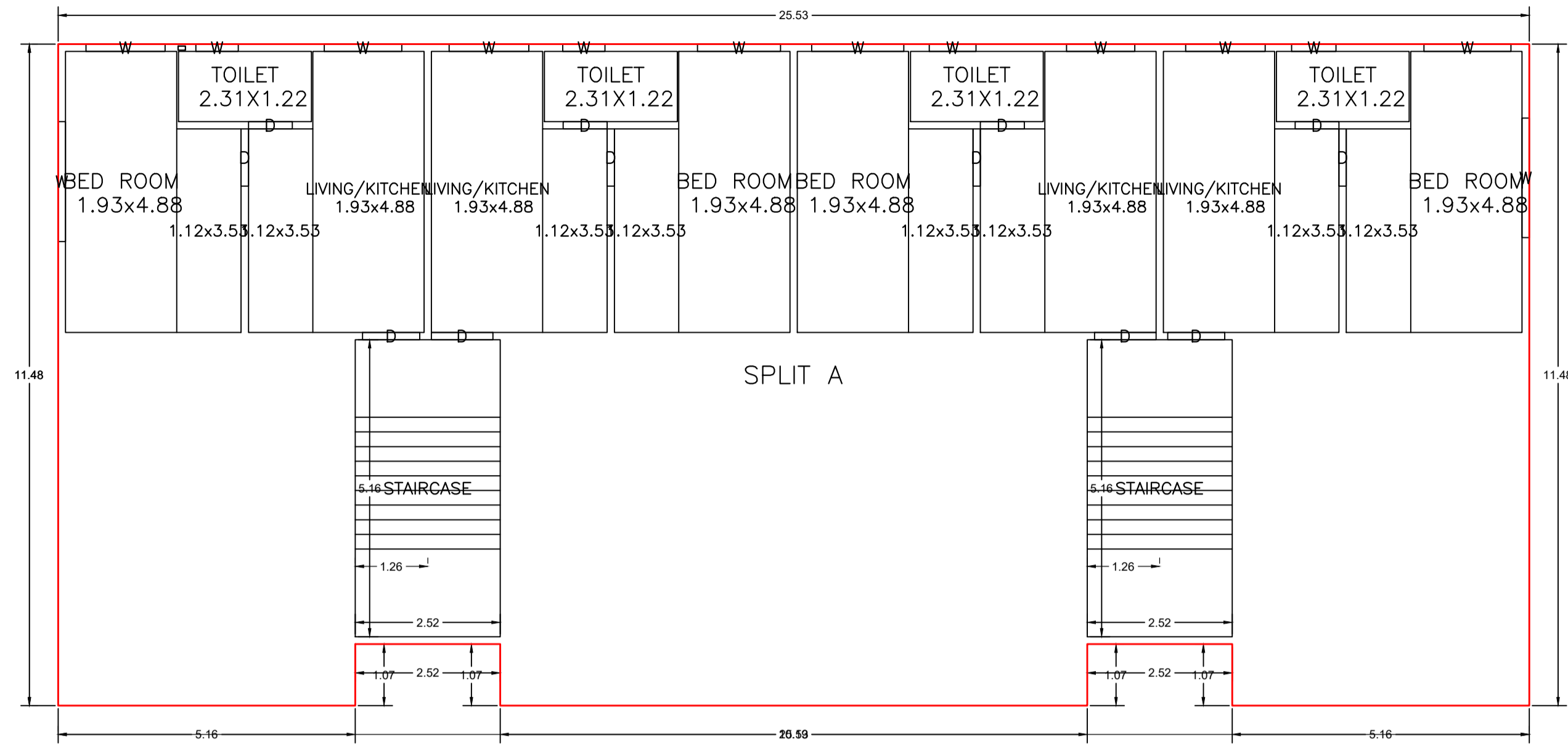

GROUND FLOOR PLAN  
(Proposed)  
(SCALE 1:100)

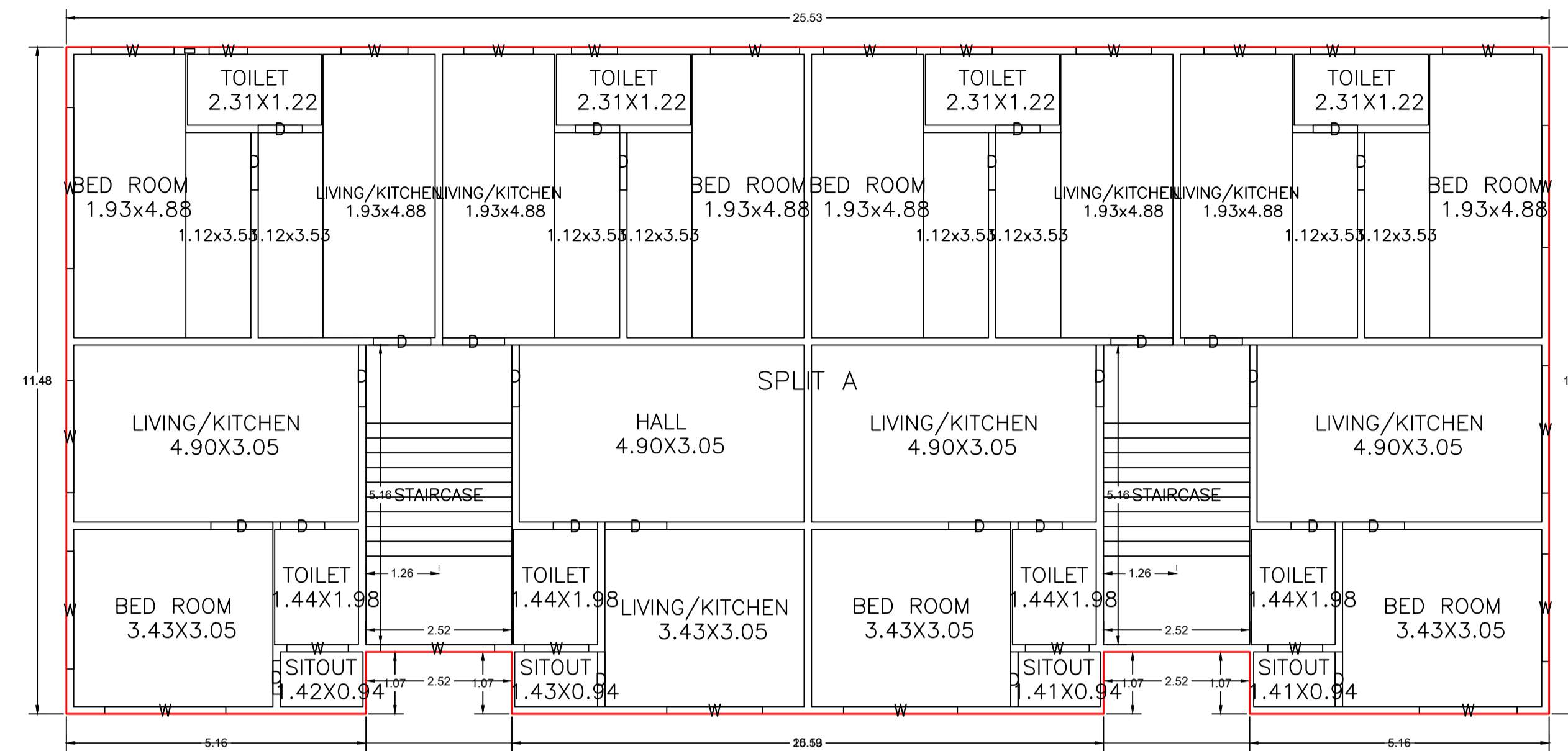

TYPICAL – 1, 2, 3 FLOOR PLAN  
(Proposed)  
(SCALE 1:100)

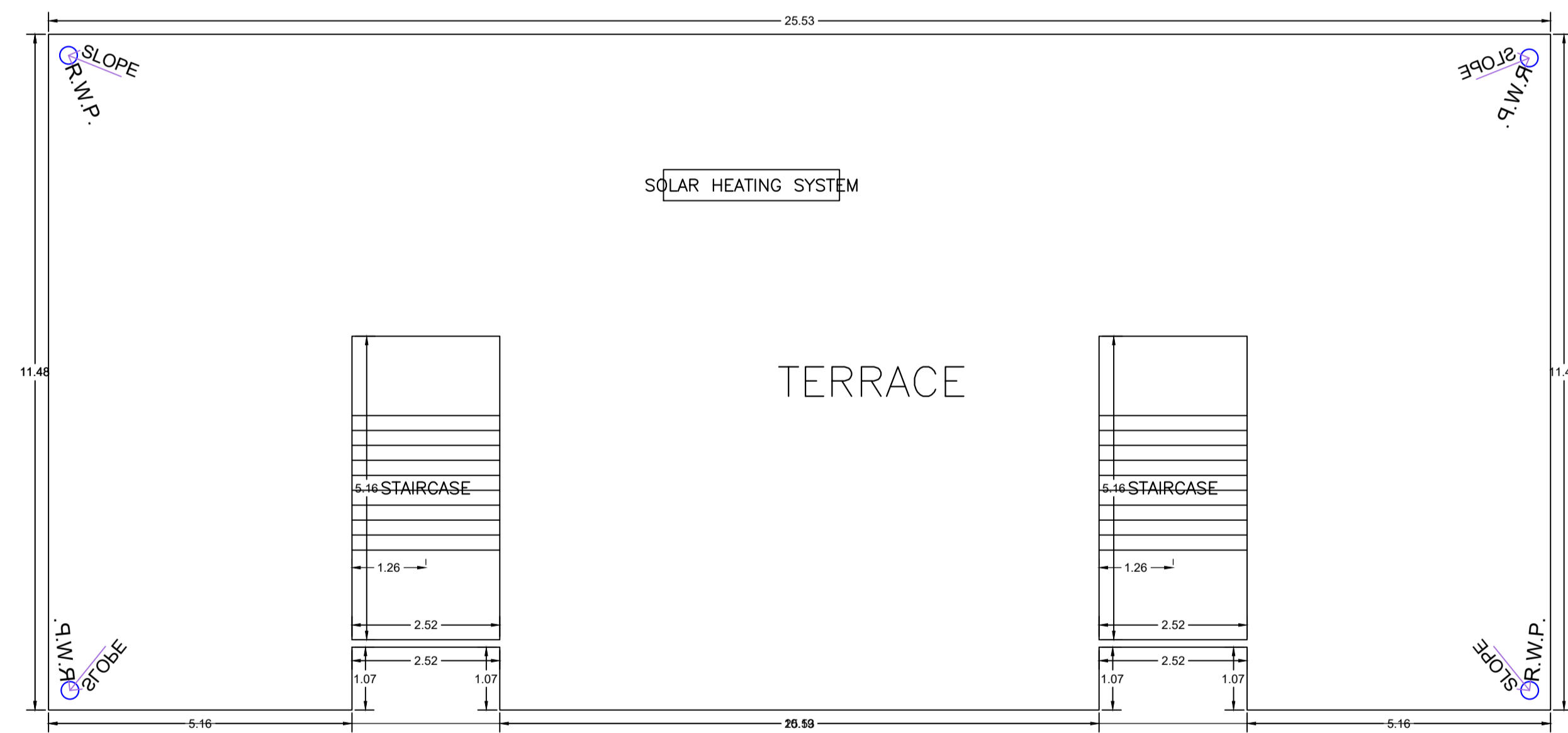

TERRACE FLOOR PLAN  
(SCALE 1:100)

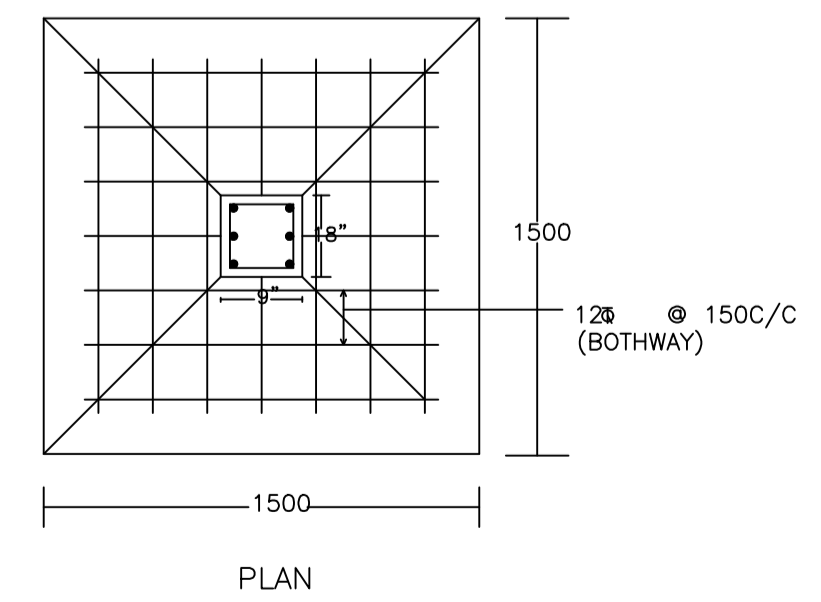
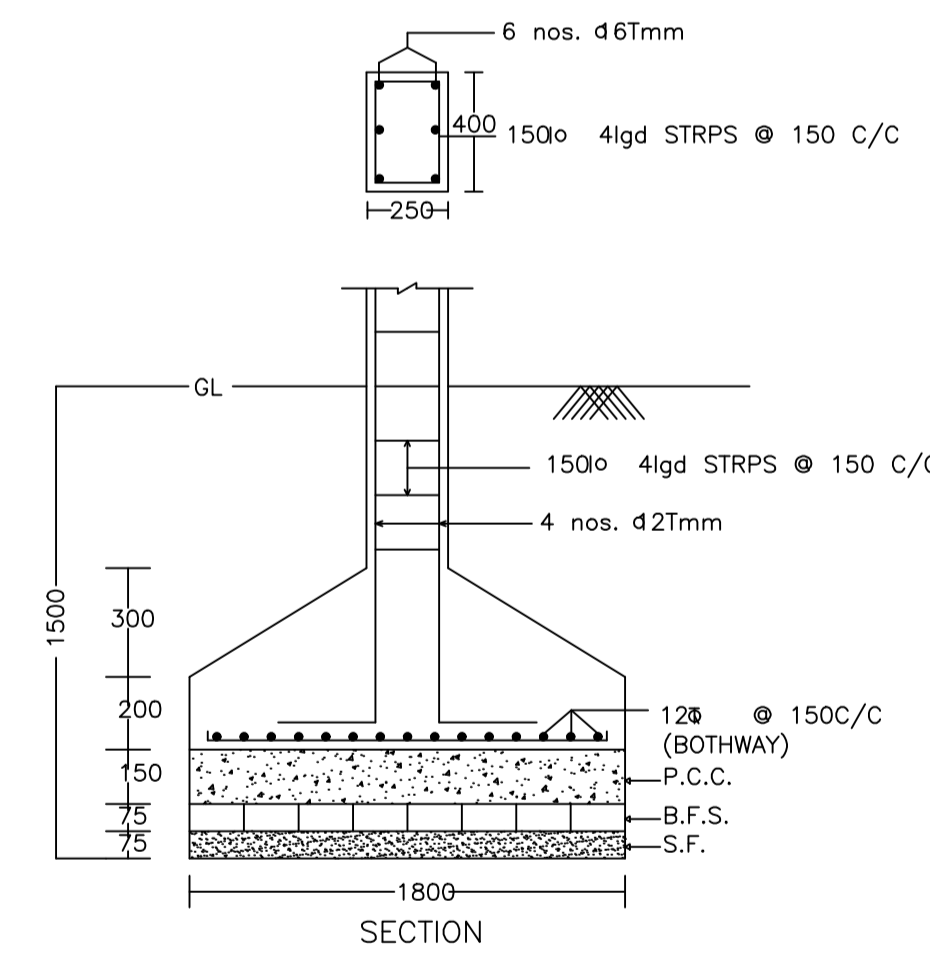

DETAIL OF COLUMNS

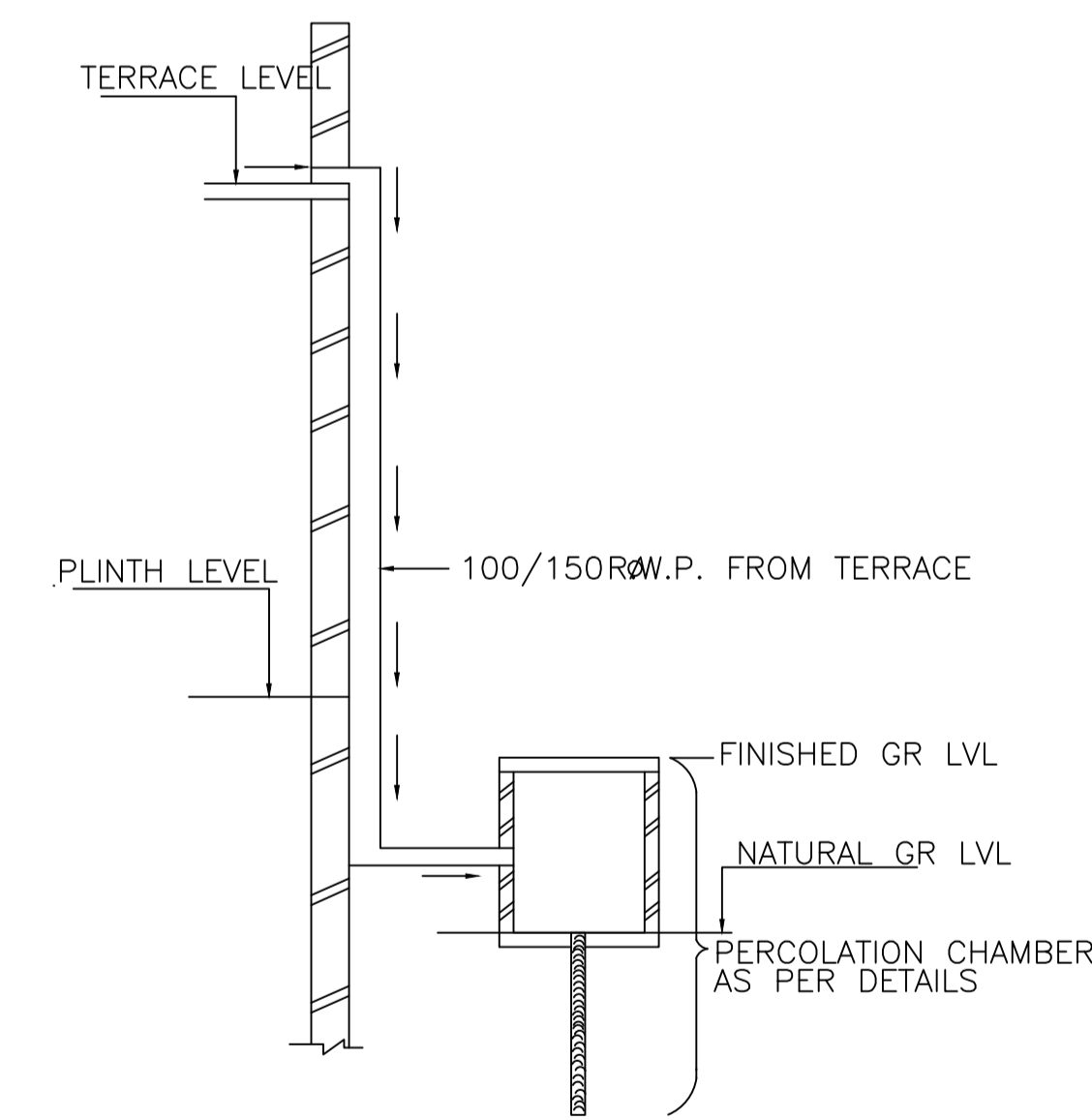

ROOF TOP RAIN WATER  
COLLECTION SYSTEM

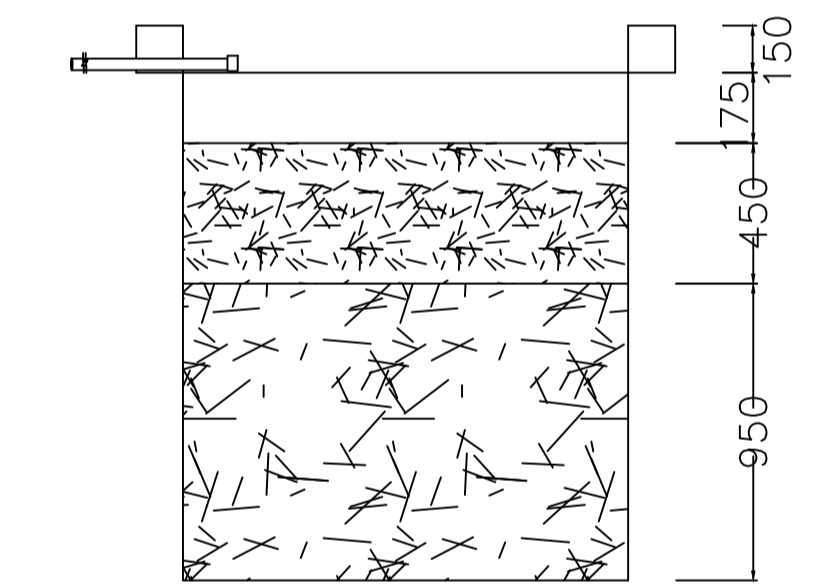

SECTION AT Y-Y

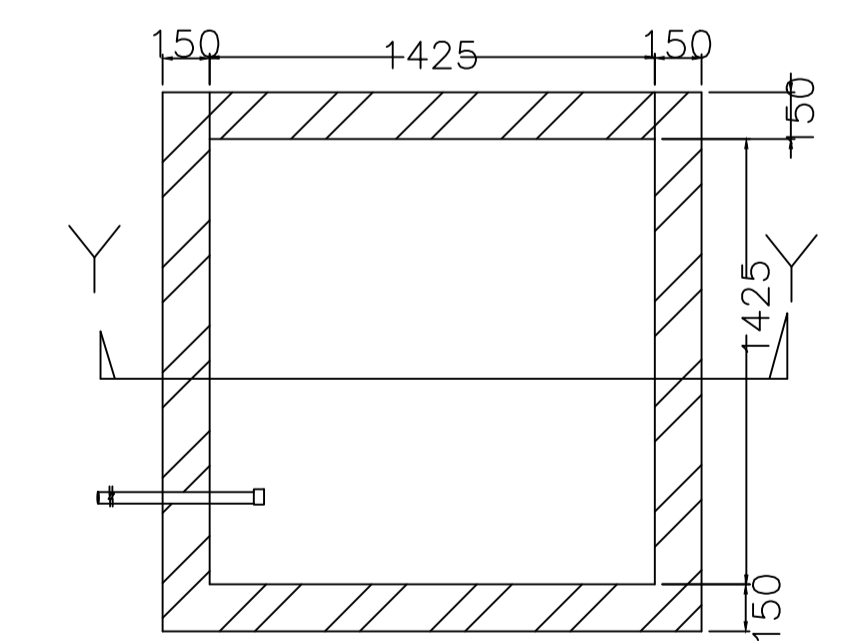

PLAN OF RECHARGE WELL  
WATER HARVESTING

LTP NAME AND SIGNATURE	STRUCTURAL ENG'S NAME AND SIGNATURE	BUILDER NAME AND SIGNATURE	DIGITAL SIGNATURE
RAJEEV RANJAN SINGH MADA/ENG/0004/2019			

Proposal Basic Information

Proposal File No.	MADA/BP/0357/2021
Owner Name	M.S. TECHNO CULTURE BUILDINGS CENTRE PVT. LTD Represent By its Director SRI DINESH KUMAR TIWARI
Khata No	29,70,NEW-78,79
Plot No	644,645,646,647,648,649,650,651,652,655,657,672,681,NEW-1468,1471,1475,1476,1477,1478,1479,1482
Village Name	Jalgora
Use	Residential
SubUse	Bungalow/ Dwelling / Non Apartment

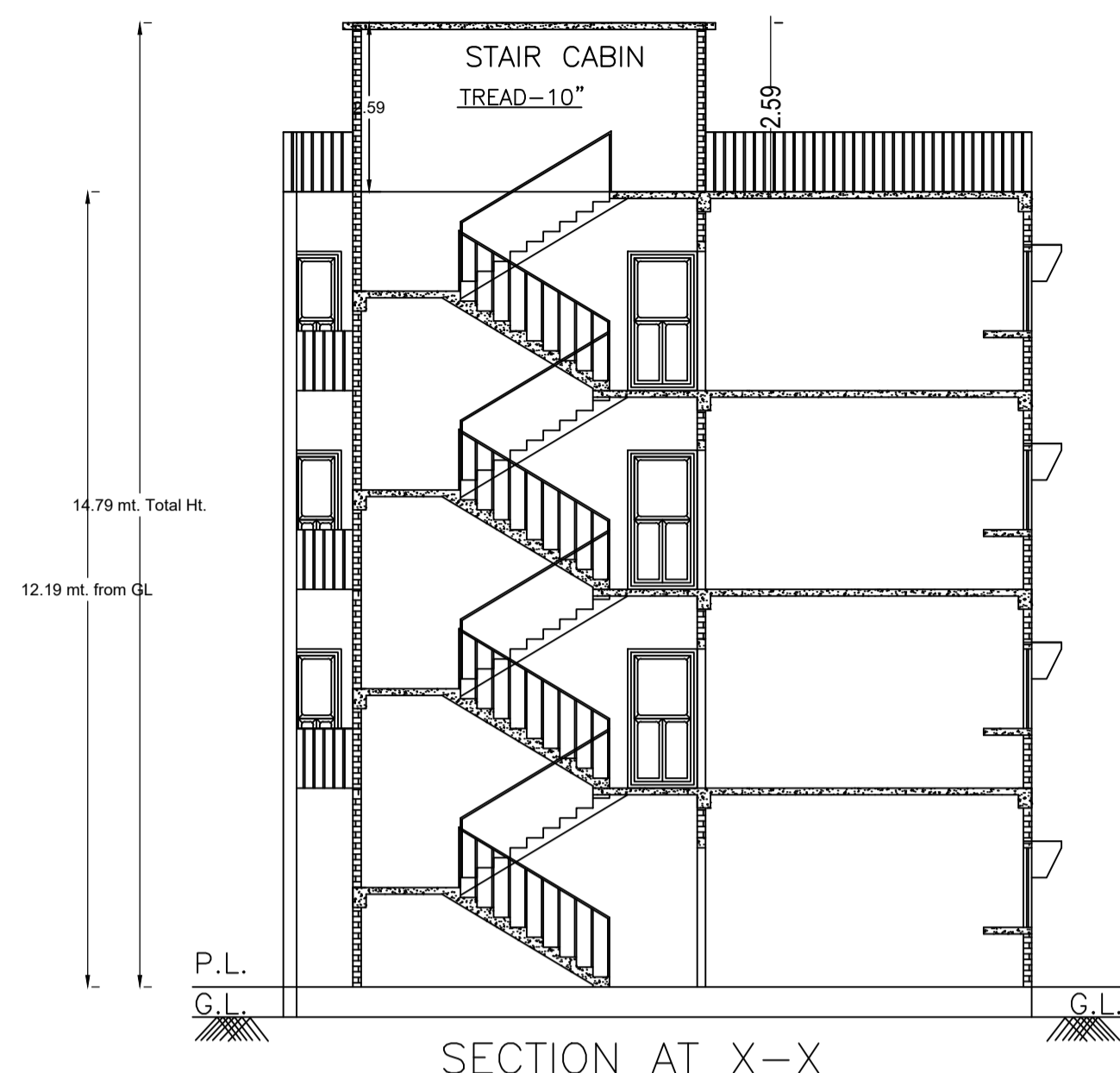

SECTION AT X-X

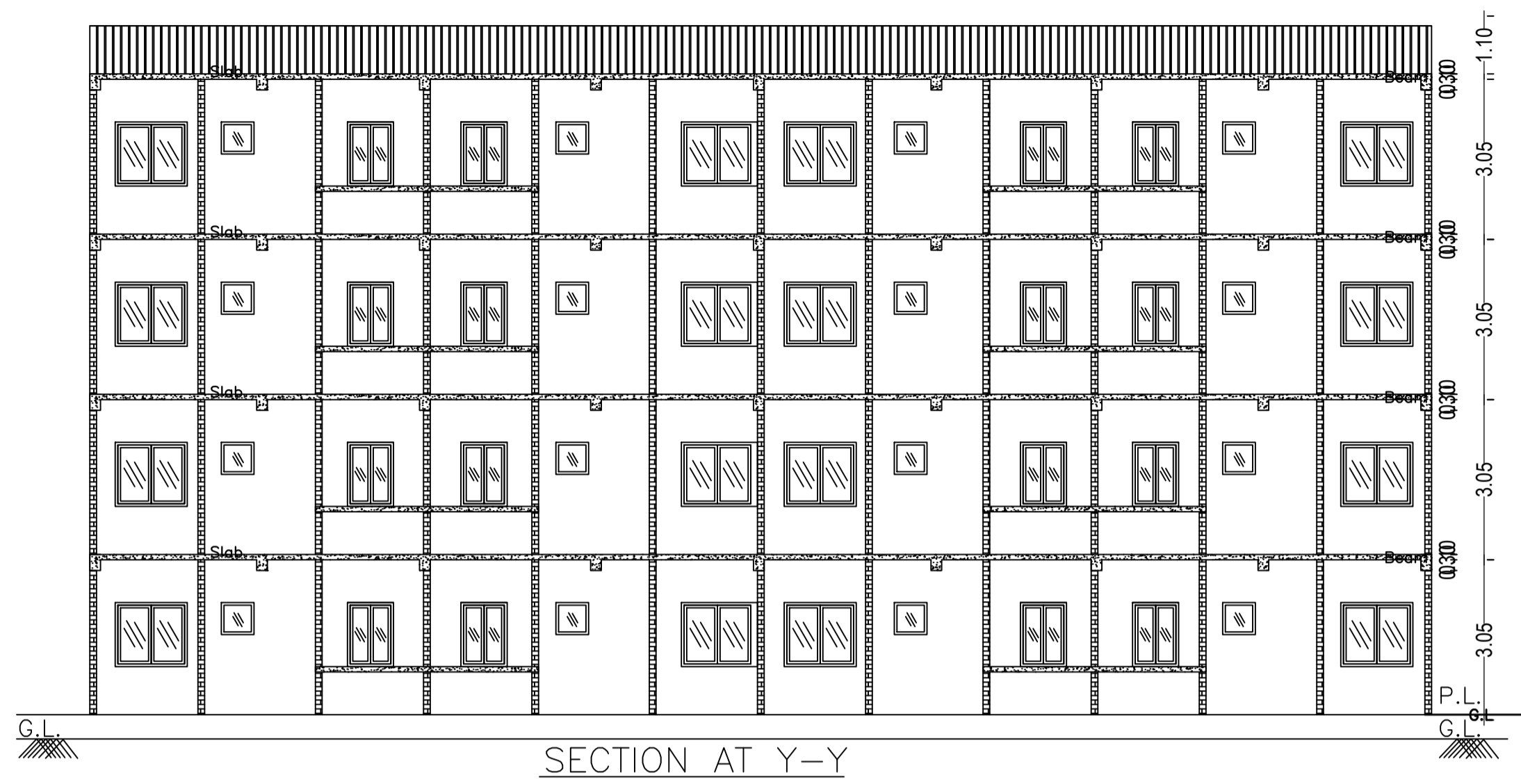

SECTION AT Y-Y

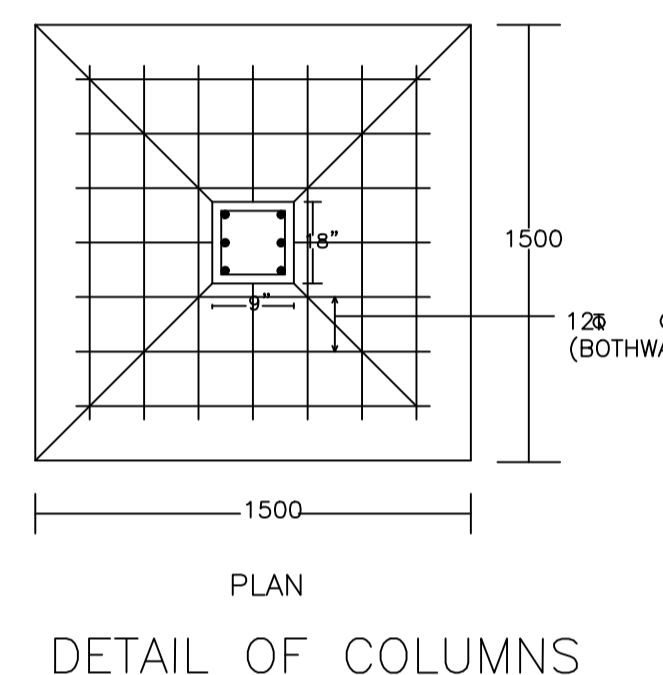
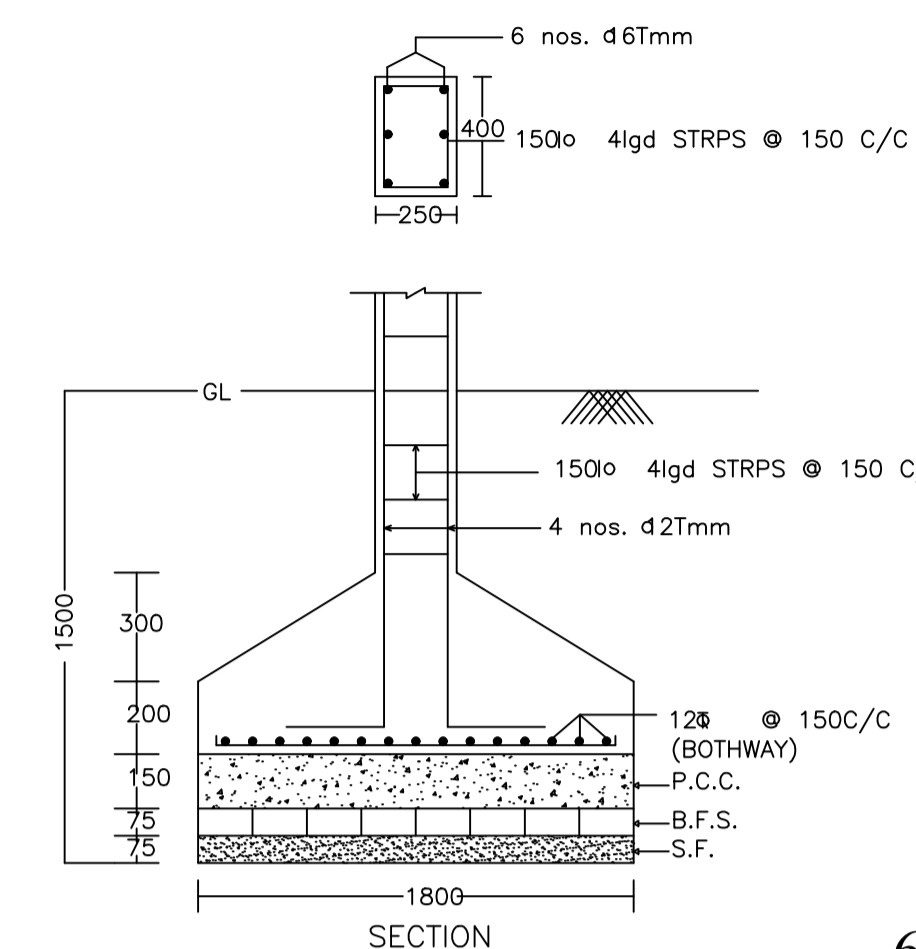

DETAIL OF COLUMNS

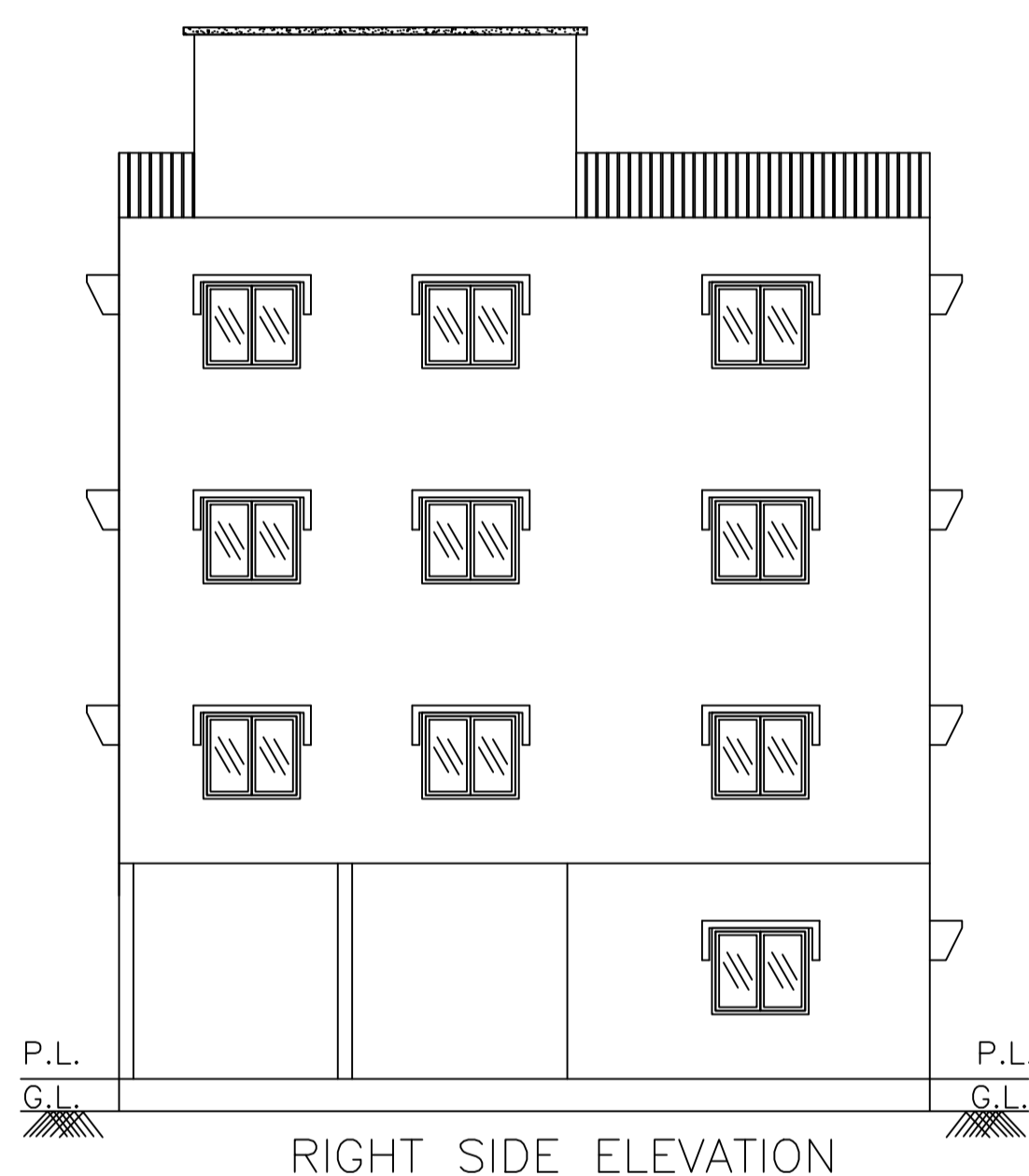
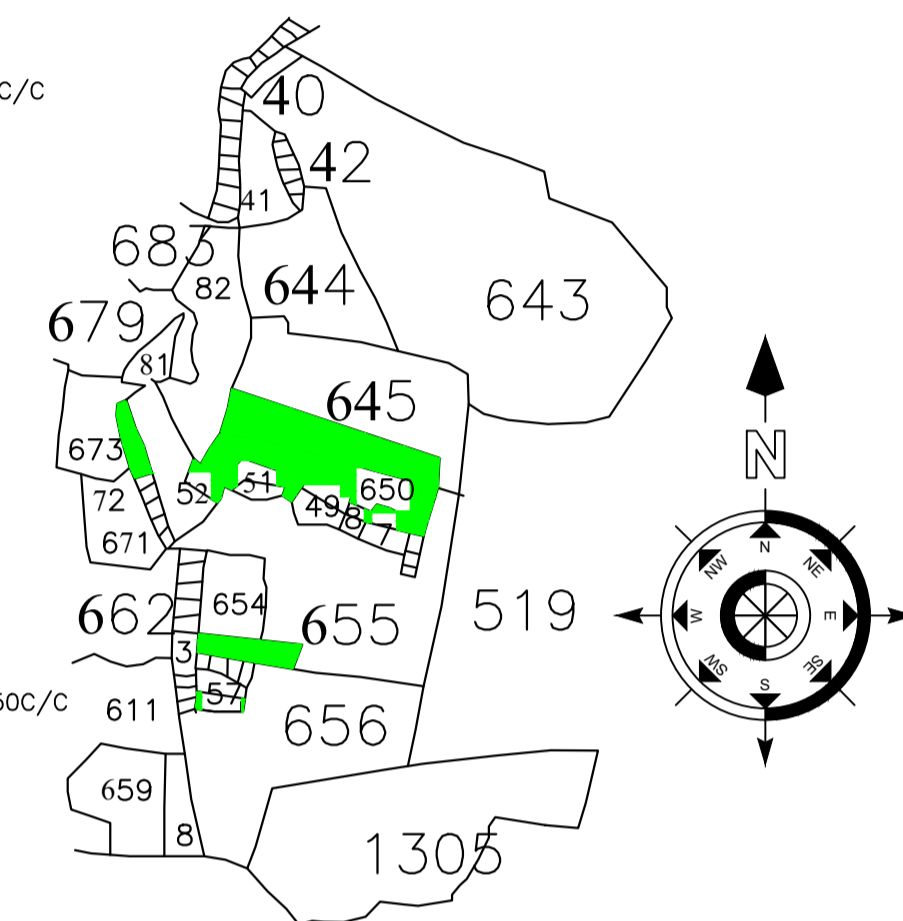

RIGHT SIDE ELEVATION

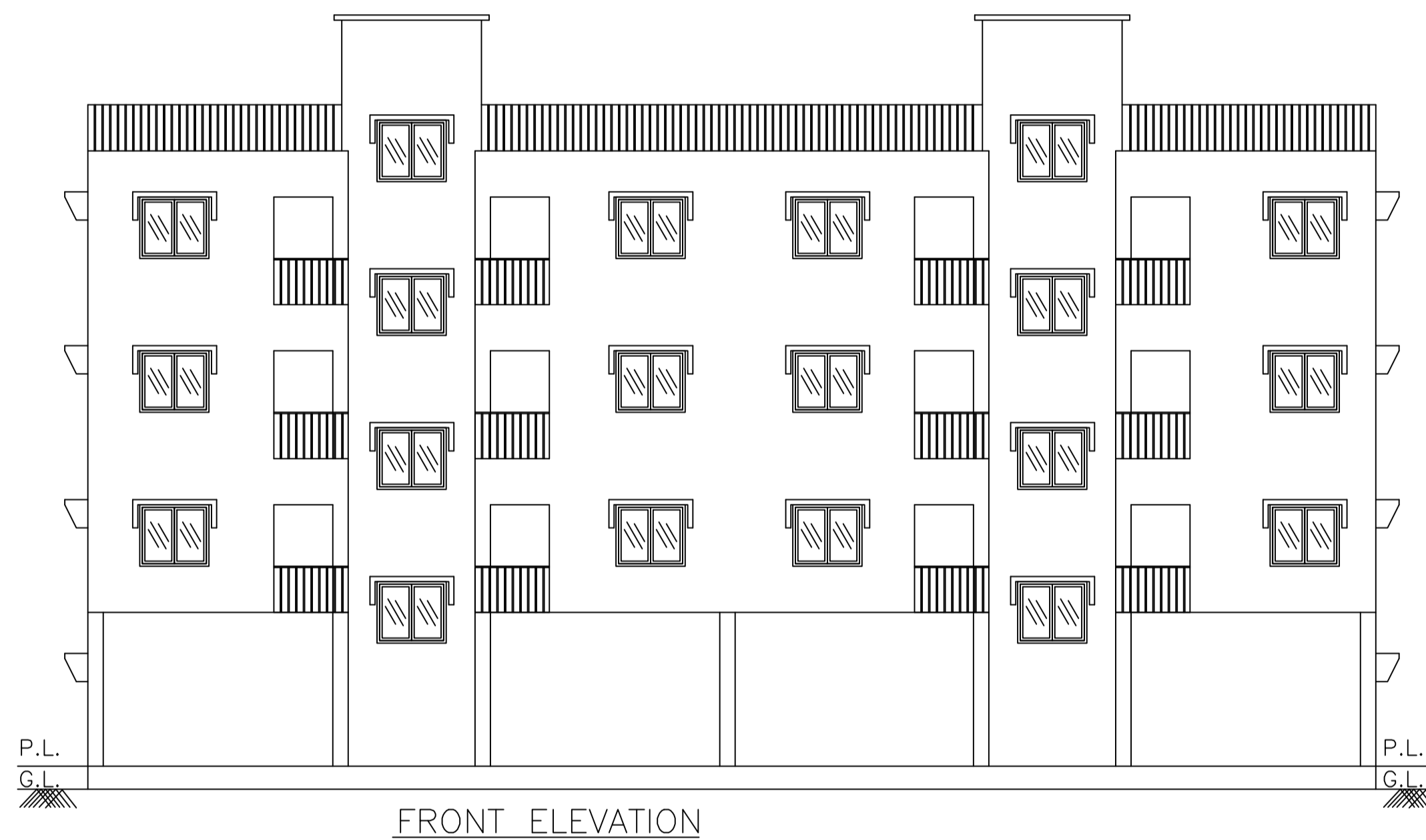

FRONT ELEVATION

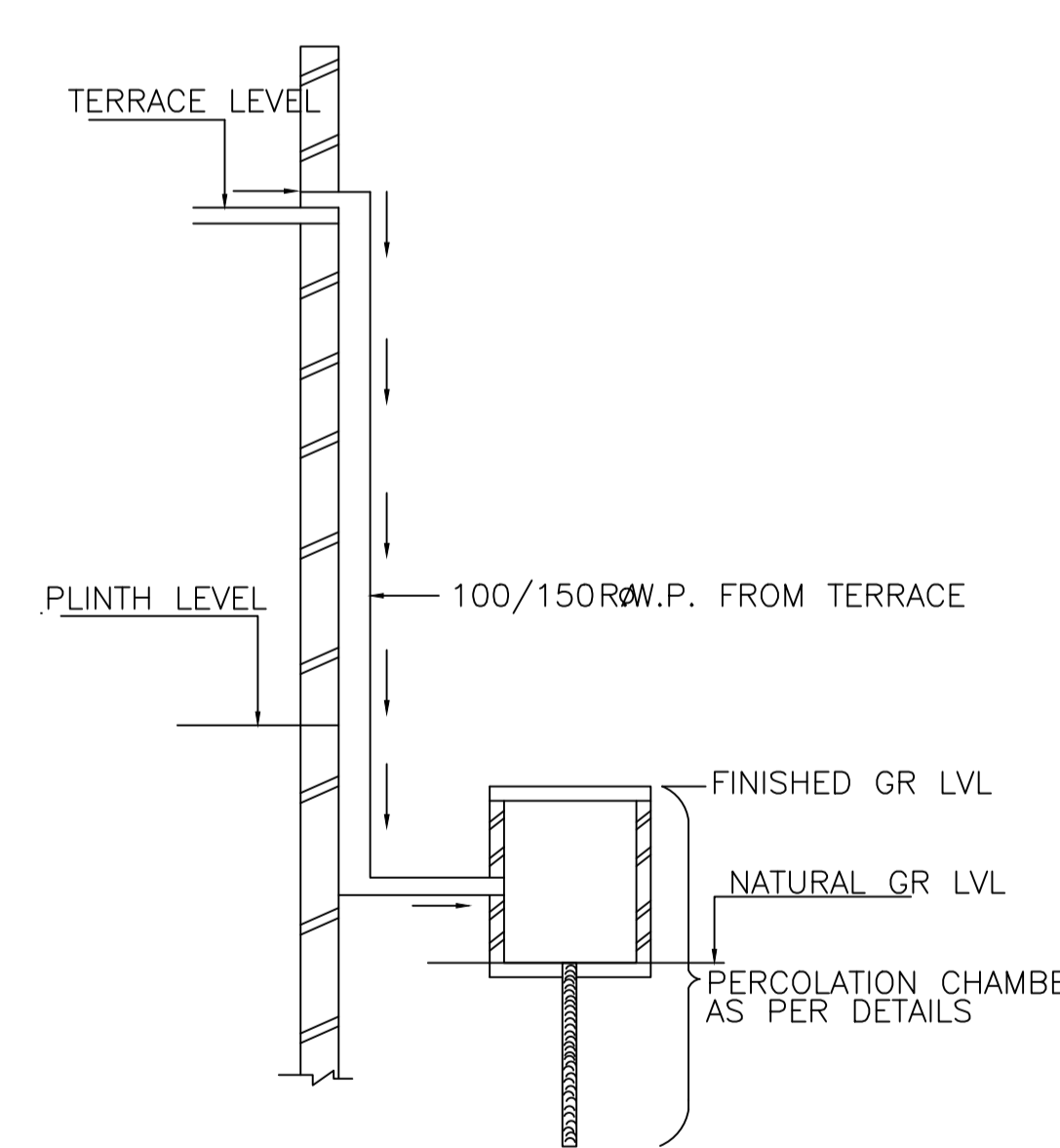

ROOF TOP RAIN WATER COLLECTION SYSTEM

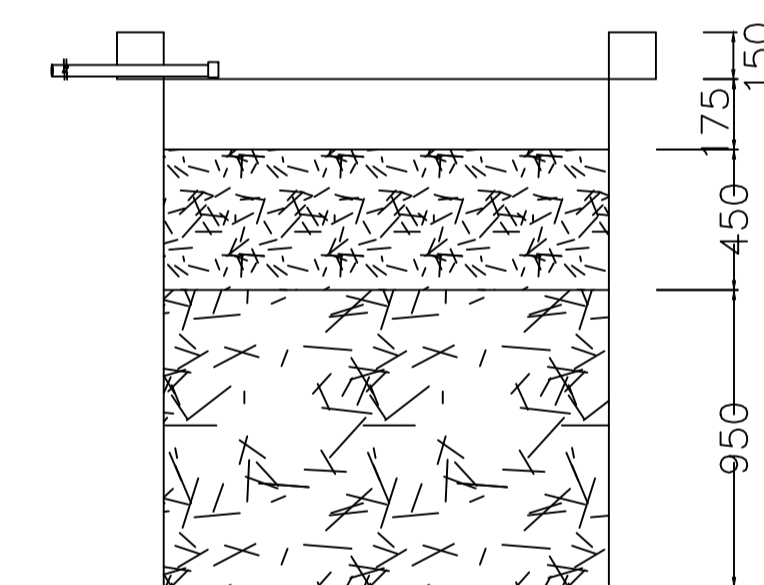

SECTION AT Y-Y

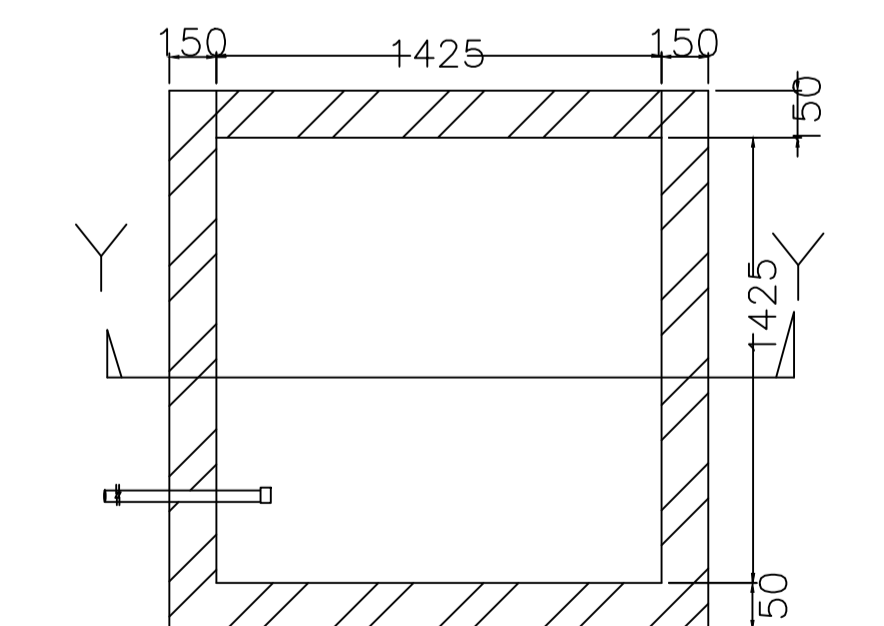

PLAN OF RECHARGE WELL WATER HARVESTING

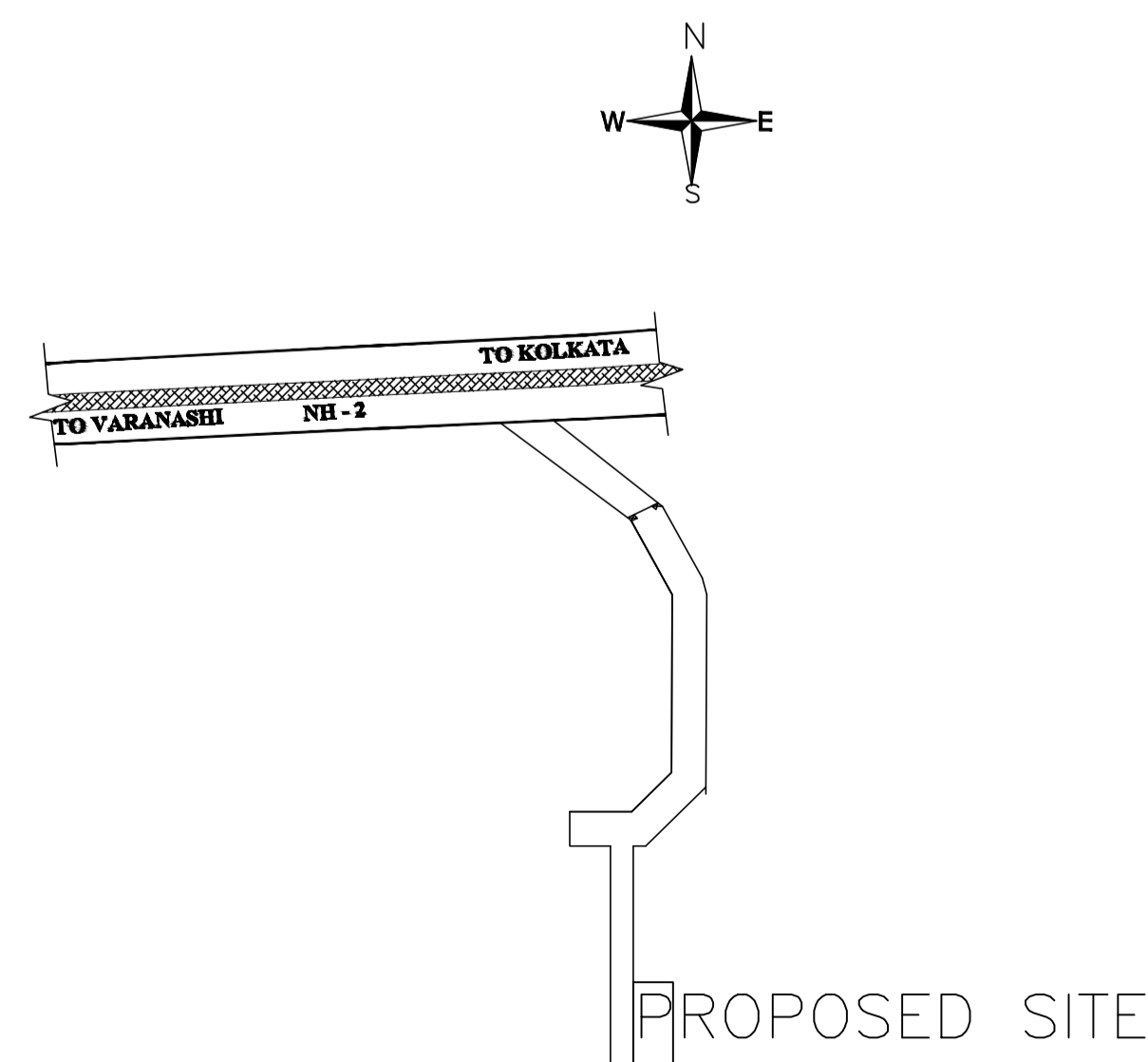

PROPOSED SITE

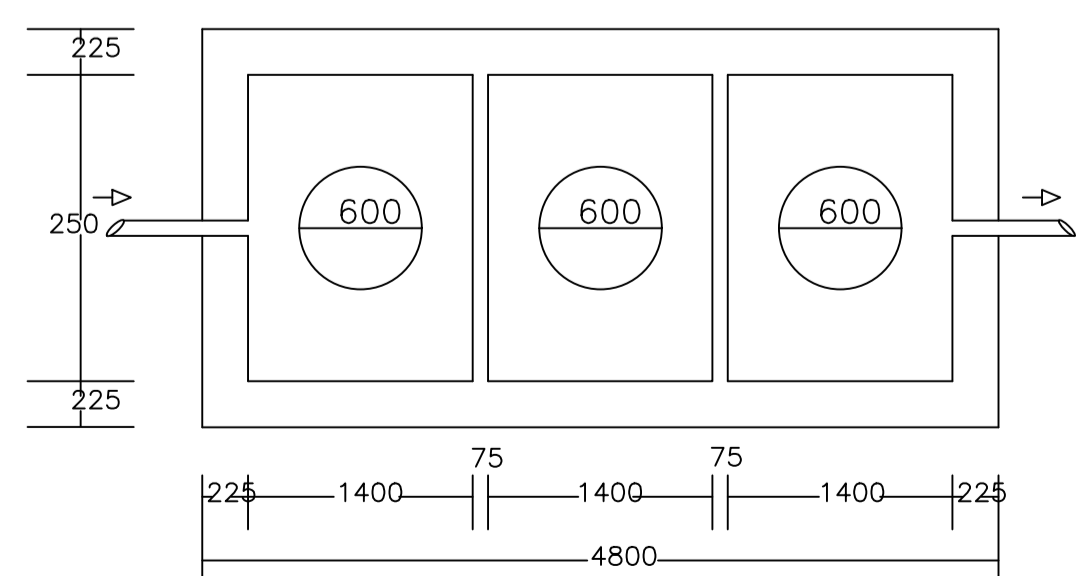
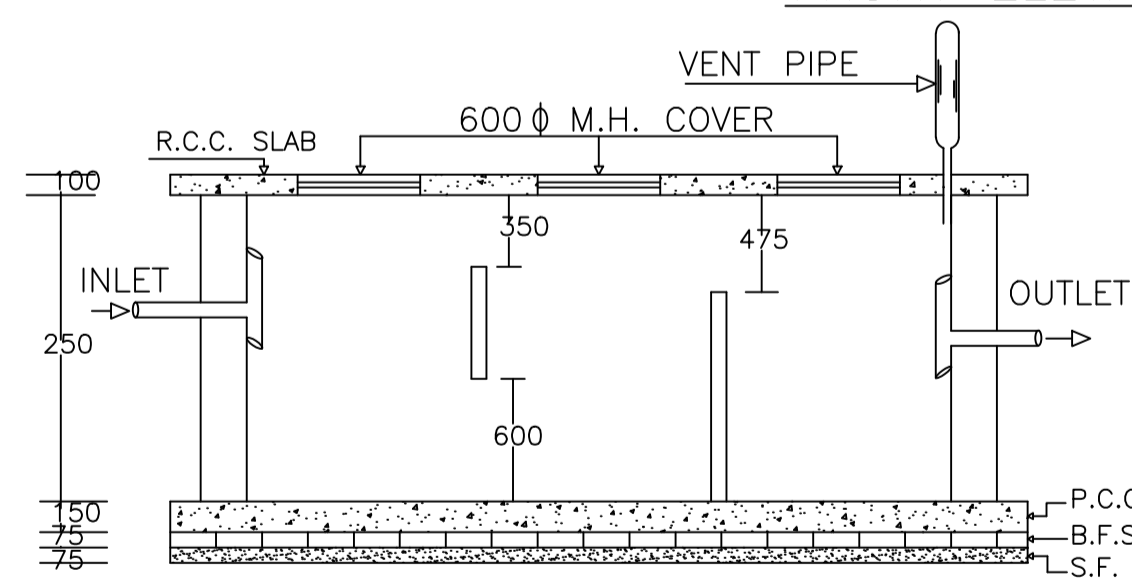

PLAN OF SEPTIC TANK

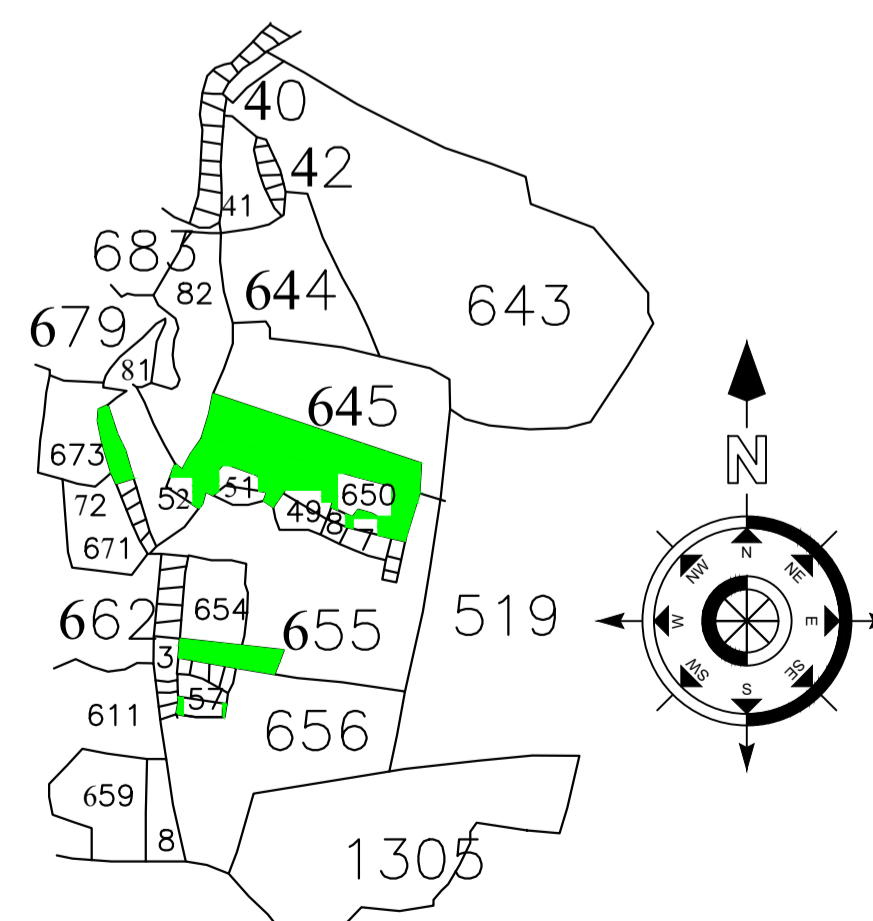

LTP NAME AND SIGNATURE	STRUCTURAL ENG'S NAME AND SIGNATURE	BUILDER NAME AND SIGNATURE	DIGITAL SIGNATURE
RAJEEV RANJAN SINGH MADA/ENG/0004/2019			