

SITE PLAN

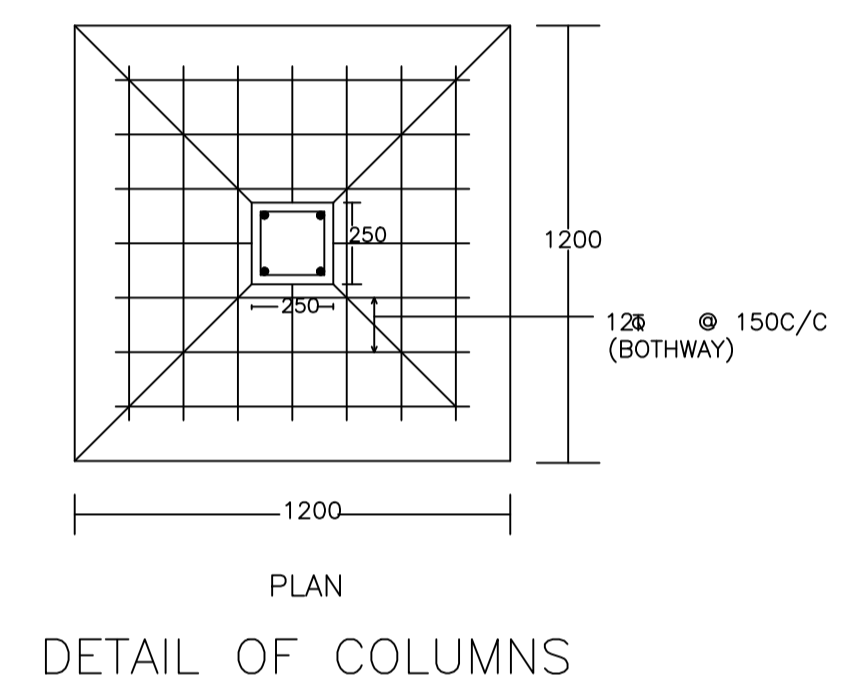

DETAIL OF COLUMNS

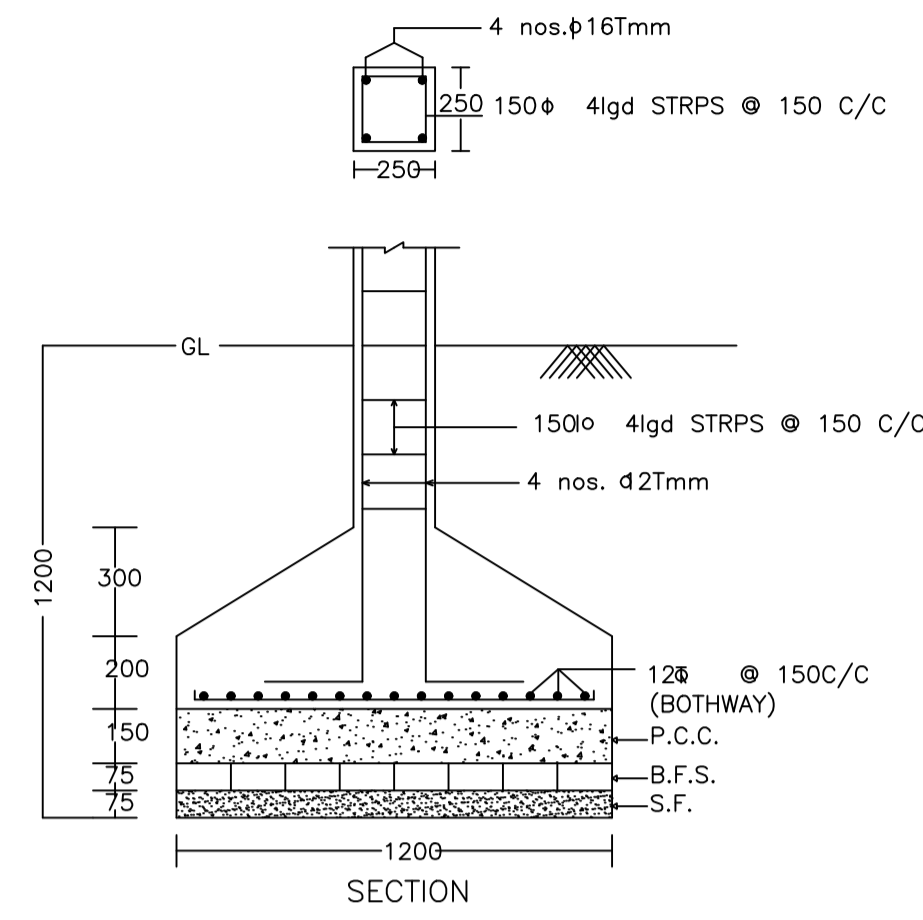
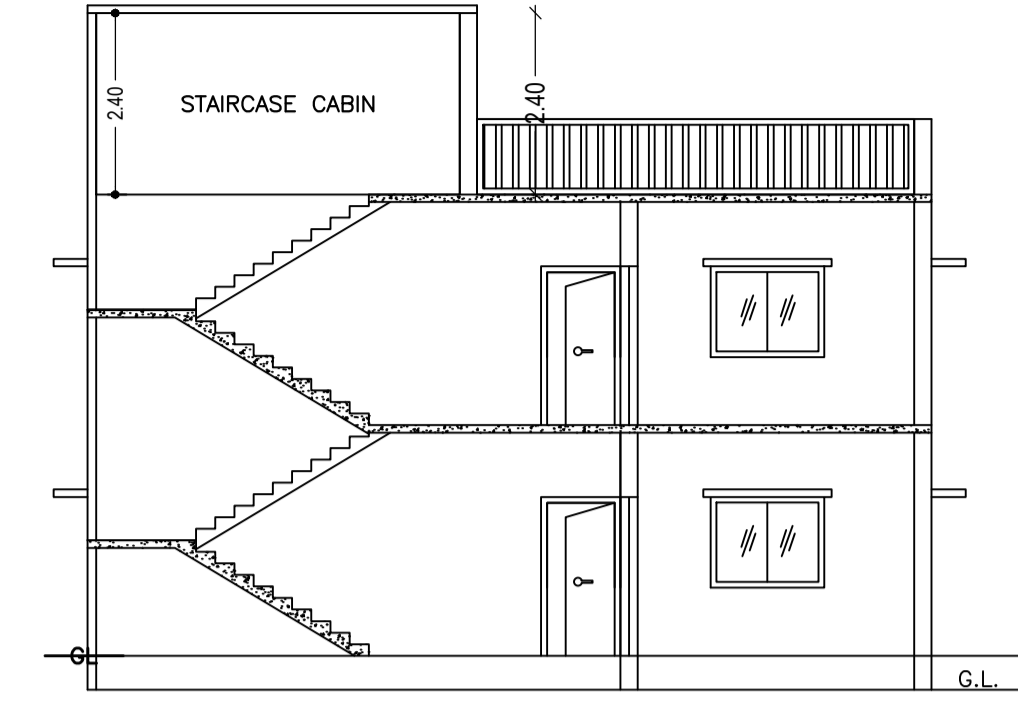

SECTION ON X-X

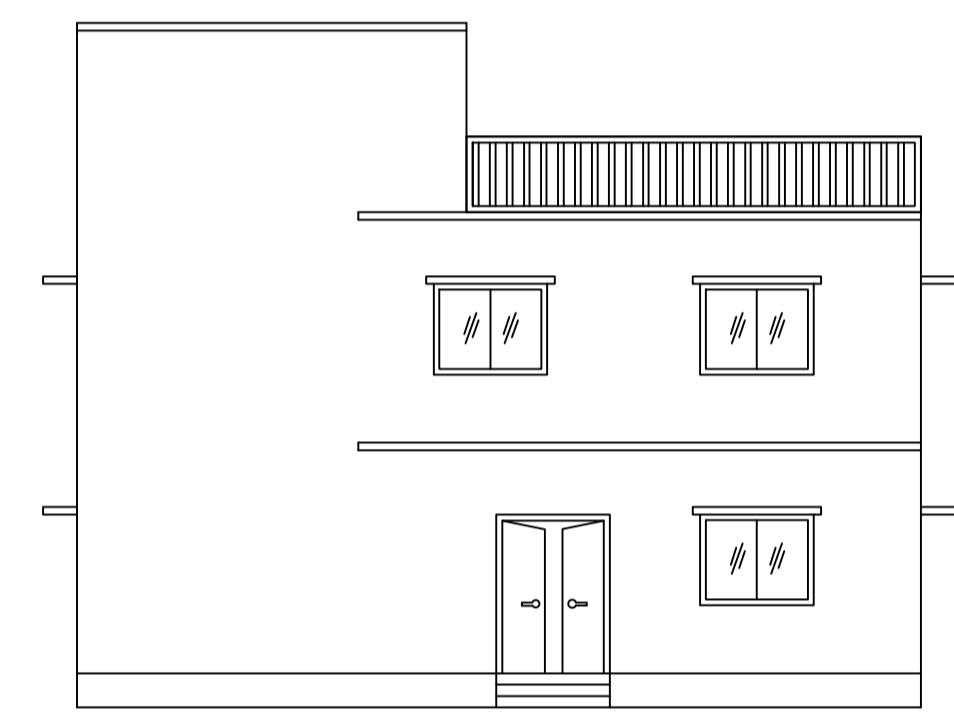

FRONT ELEVATION

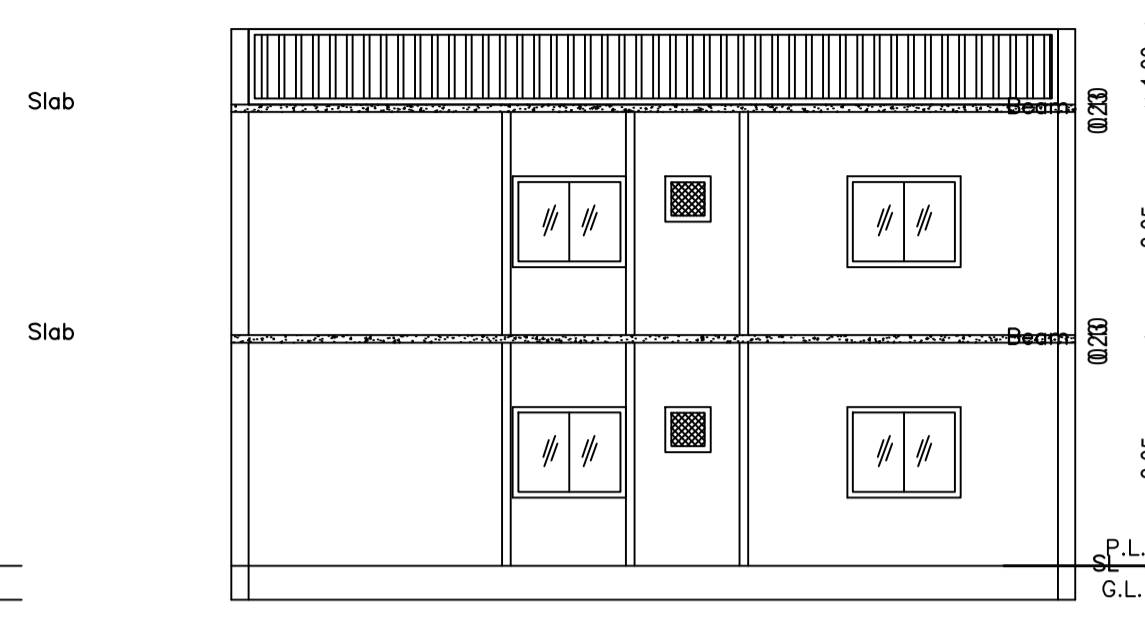

SECTION ON Y-Y

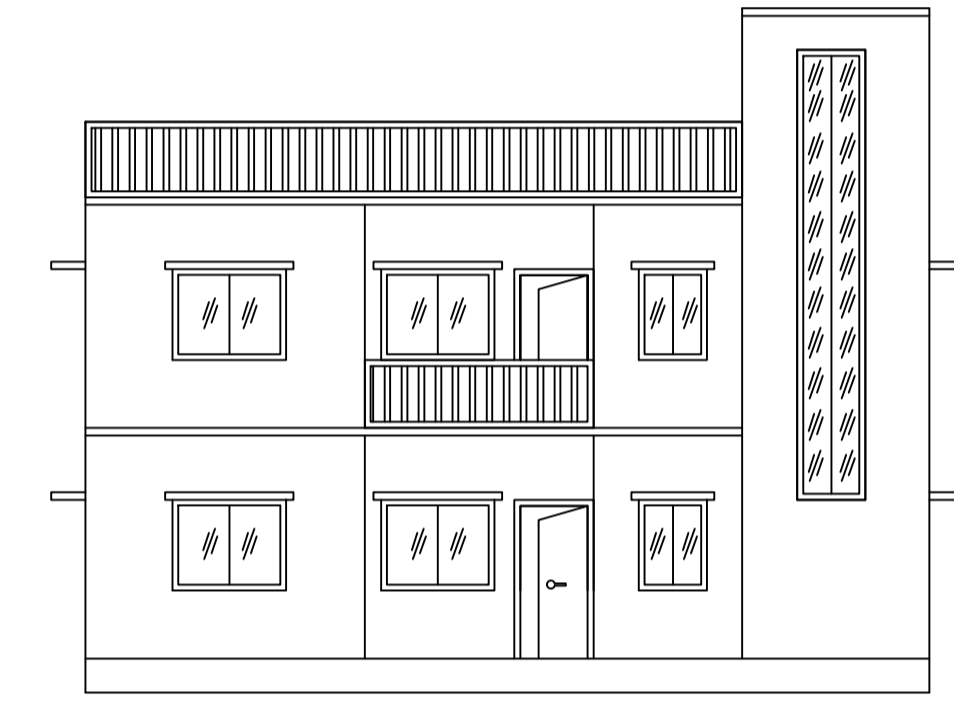

LEFT SIDE ELEVATION

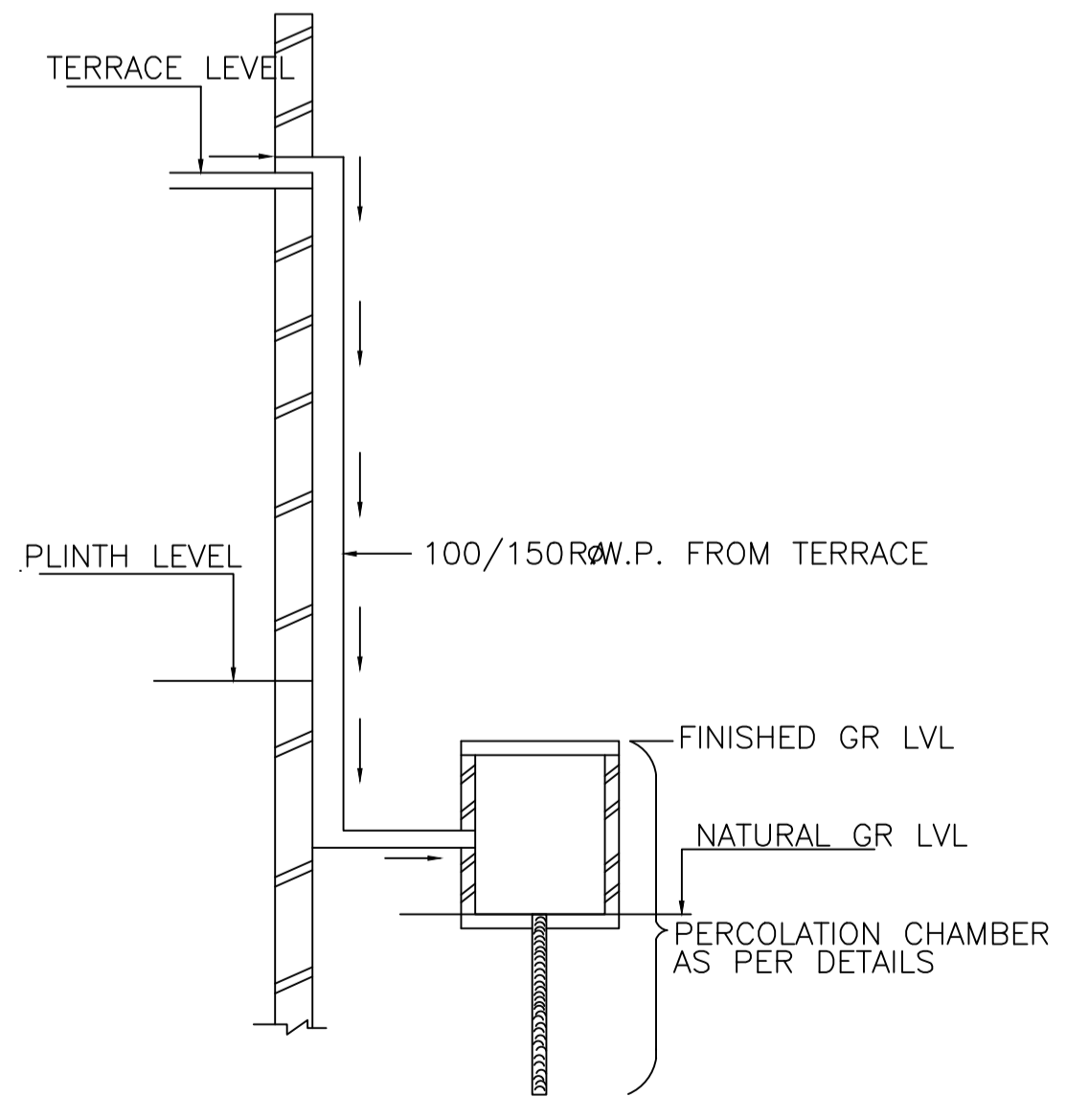

ROOF TOP RAIN WATER COLLECTION SYSTEM

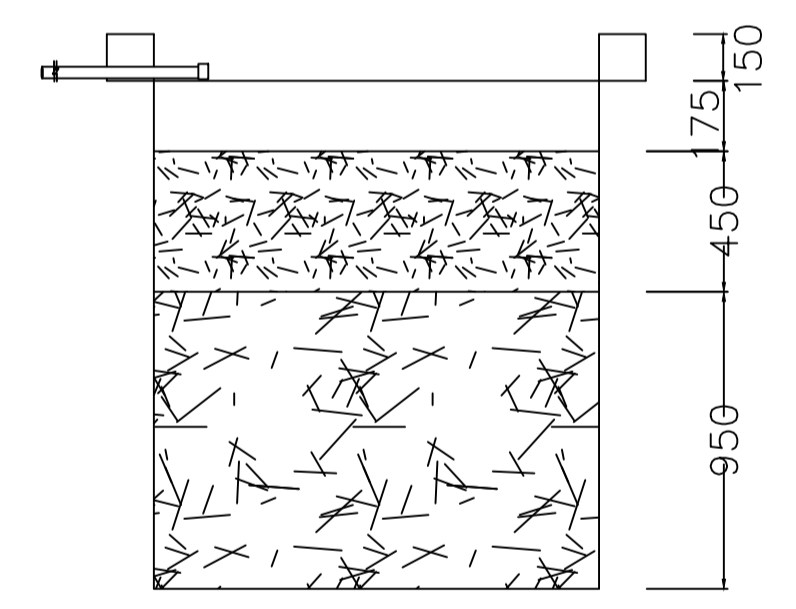

SECTION AT Y-Y

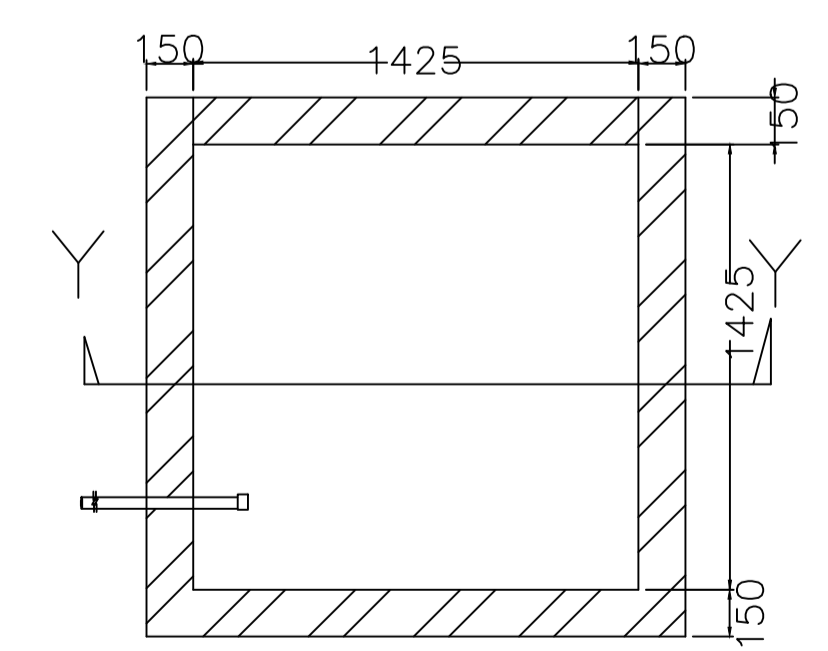

PLAN OF RECHARGE WELL WATER HARVESTING

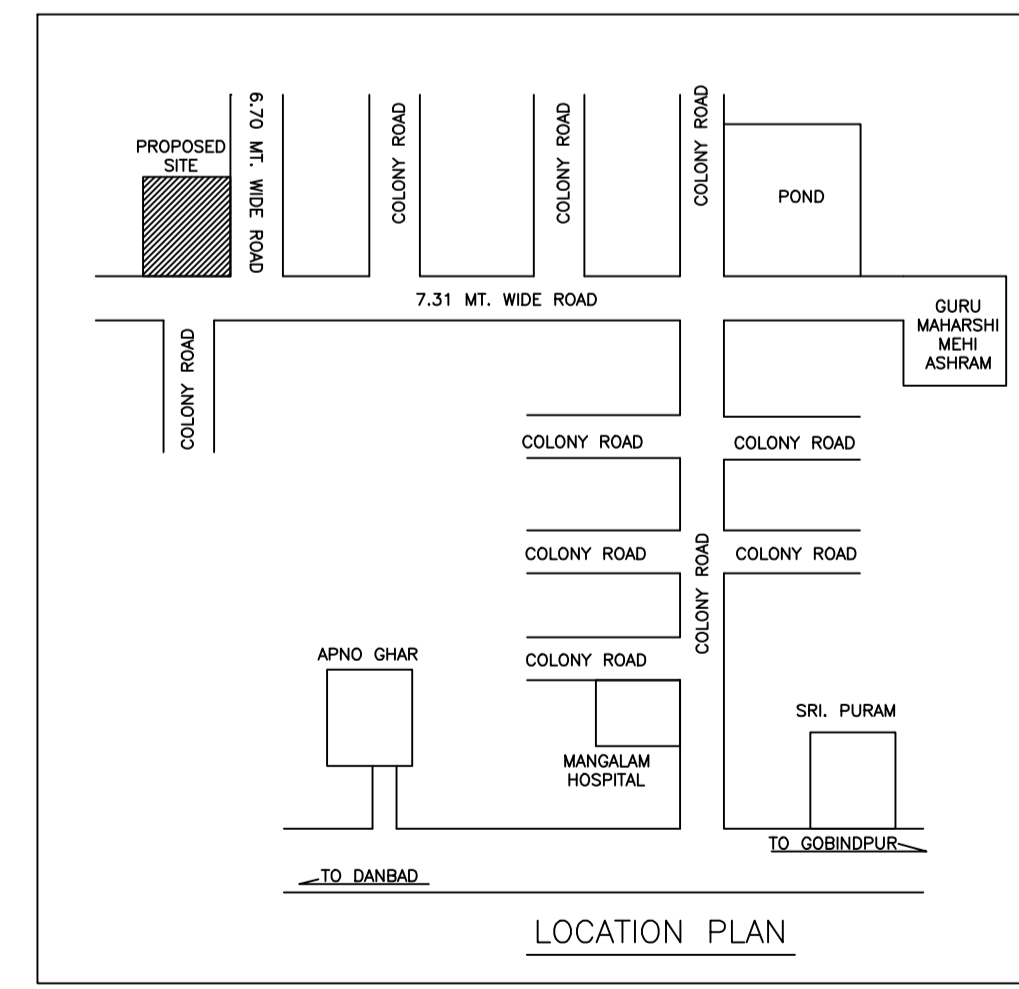

LOCATION PLAN

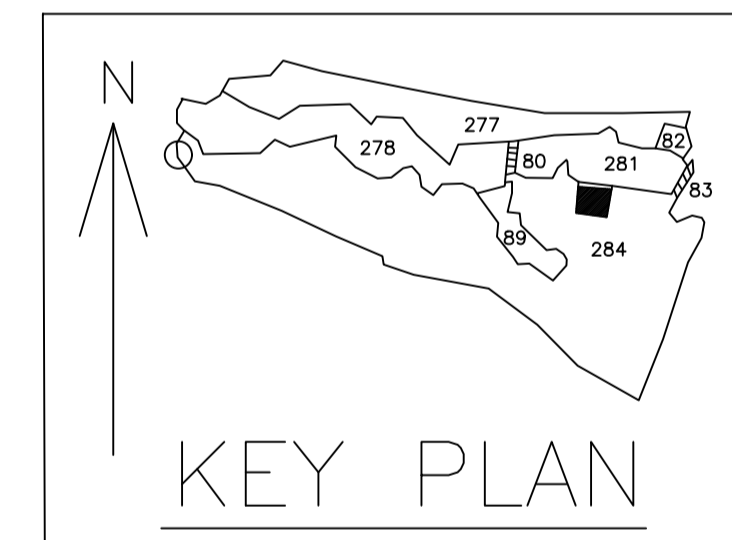

KEY PLAN

SCHEDULE OF DOOR:

BUILDING NAME	NAME	LENGTH	HEIGHT	NOS
A (A)	D	0.75	2.10	04
A (A)	D	0.90	2.10	02
A (A)	D	1.05	2.10	12
A (A)	D	1.50	2.10	01

SCHEDULE OF WINDOW/VENTILATION:

BUILDING NAME	NAME	LENGTH	HEIGHT	NOS
A (A)	V	0.60	1.20	04
A (A)	W	0.90	1.20	02
A (A)	W	1.50	1.20	15

Building :A (A)

Floor Name	Total Built Up Area (Sq.mt.)	Proposed FAR Area (Sq.mt.)	Total FAR Area (Sq.mt.)	Total Consumed Additional FAR Area (Sq.mt.)	Tnmt (No.)
Ground Floor	124.62	124.62	124.62	124.62	01
First Floor	124.62	124.62	124.62	124.62	00
Terrace Floor	0.00	0.00	0.00	0.00	00
Total :	249.24	249.24	249.24	249.24	01
Total Number of Same Buildings :	1				
Total :	249.24	249.24	249.24	249.24	01

Proposal Basic Information

Proposal File No.	MADA/BP/0282/2021
Owner Name	SURENDRA KUMAR
Khata No	OLD-17, NEW-53
Plot No	OLD-284, NEW-354
Village Name	Kangalo
Use	Residential
SubUse	Bungalow/ Dwelling / Non Apartment

AREA STATEMENT MINERAL AREA DEVELOPMENT AUTHORITY	VERSION NO.: 1.0.61	VERSION DATE: 16/10/2020
PROJECT DETAIL:		
Region: JHARKHAND URBAN LOCAL BODIES	Plot Use: Residential	
District: DHANBAD	Plot SubUse: Bungalow/ Dwelling / Non Apartment	
Authority: MINERAL AREA DEVELOPMENT AUTHORITY	PlotNearby/ReligiousStructure: NA	
Inward No: MADA/BP/0282/2021	Plot/SubPlot No: OLD-284, NEW-354	
Application Type: General Proposal	North: Plot No. - 52	
Project Type: Building Permission	South: Road Width - 7.31	
Nature of Development: New	East: Road Width - 6.7	
Location of Development Area: Old Area	West: Plot No. - 59	
AREA DETAILS:		
AREA OF PLOT (Minimum)	(A)	SQ.MT. 251.33
NET AREA OF PLOT(Gross Plot Area - Deduction from Gross Plot area)	(A-Deductions)	251.33
Deduction for Balance Plot Area(from Gross Plot Area)		
Common Plot		29.23
Total		29.23
BALANCE AREA OF PLOT(Net Plot Area - Recreational/Amenity space)	(A-Deductions)	222.11
PLOT AREA FOR COVERAGE(Net Plot Area)	(A-Deductions)	251.33
Plot Area for FAR (Net Plot Area + Road Widening Area)	(A-Deductions)	251.33
COVERAGE CHECK		
Permissible Coverage area (60.00 %)		150.80
Proposed Coverage Area (49.58 %)		124.62
Total Prop. Coverage Area (49.58 %)		124.62
Balance coverage area (10.42 %)		26.18
FAR CHECK		
Perm. FAR Area (2.50)		628.33
Total Perm. FAR area		628.33
Residential FAR		249.24
Proposed FAR Area		249.24
Total Proposed FAR Area		249.24
Consumed FAR (Factor)		0.99
Balance FAR Area		379.09
BUILT UP AREA CHECK		
Total Proposed BuiltUp Area		249.24
ARCHITECT (Regd)	SANJEEV KUMAR RAY	
ENGINEER (Regd)		
SUPERVISOR (Regd)		
OWNER (Regd)	SURENDRA KUMAR	
DEVELOPMENT AUTHORITY LOCAL BODY		

COLOR INDEX	
PLOT BOUNDARY	Black
ABUTTING ROAD	Green
PROPOSED CONSTRUCTION	Red
COMMON PLOT	Yellow
ROAD WIDENING AREA	Blue
EXISTING (To be retained)	Light Blue
EXISTING (To be demolished)	Dark Blue

Buildingwise Floor FAR Details

Floor Name	Building Name A (A)		Total	
	Proposed Built Up Area (Sq.mt.)	Proposed FAR Area (Sq.mt.)	Total Proposed Built Up Area (Sq.mt.)	Total FAR Area (Sq.mt.)
Ground Floor	124.62	124.62	124.62	124.62
First Floor	124.62	124.62	124.62	124.62
Terrace Floor	0.00	0.00	0.00	0.00
Total :	249.24	249.24	249.24	249.24

Building USE/SUBUSE Details

Building Name	Building Use	Building SubUse	Building Structure
A (A)	Residential	Residential Bldg/Apartment	Non-Highrise

UnitBUA Table for Building :A (A)

FLOOR	Name	UnitBUA Type	UnitBUA Area	Carpet Area	No. of Rooms	No. of Tenement
GROUND FLOOR PLAN	SPLIT A	FLAT	249.24	249.17	9	1
FIRST FLOOR PLAN	SPLIT A	FLAT	0.00	0.00	9	0
Total:	-	-	249.24	249.17	18	1

FAR & Tenement Details (Table 4c-1)

Building	No. of Same Bldg	Total Built Up Area (Sq.mt.)	Proposed FAR Area (Sq.mt.) Resi.	Total FAR Area (Sq.mt.)	Total Consumed Additional FAR Area (Sq.mt.)	Tnmt (No.)
A (A)	1	249.24	249.24	249.24	249.24	01
Grand Total :	1	249.24	249.24	249.24	249.24	01

LTP NAME AND SIGNATURE	STRUCTURAL ENG'S NAME AND SIGNATURE	BUILDER NAME AND SIGNATURE	DIGITAL SIGNATURE
SANJEEV KUMAR RAY MADA/ENG/0021/2019			

Proposal Basic Information

Proposal File No.	MADA/BP/0282/2021
Owner Name	SURENDRA KUMAR
Khata No	OLD-17, NEW-53
Plot No	OLD-284, NEW-354
Village Name	Kangalo
Use	Residential
SubUse	Bungalow/ Dwelling / Non Apartment

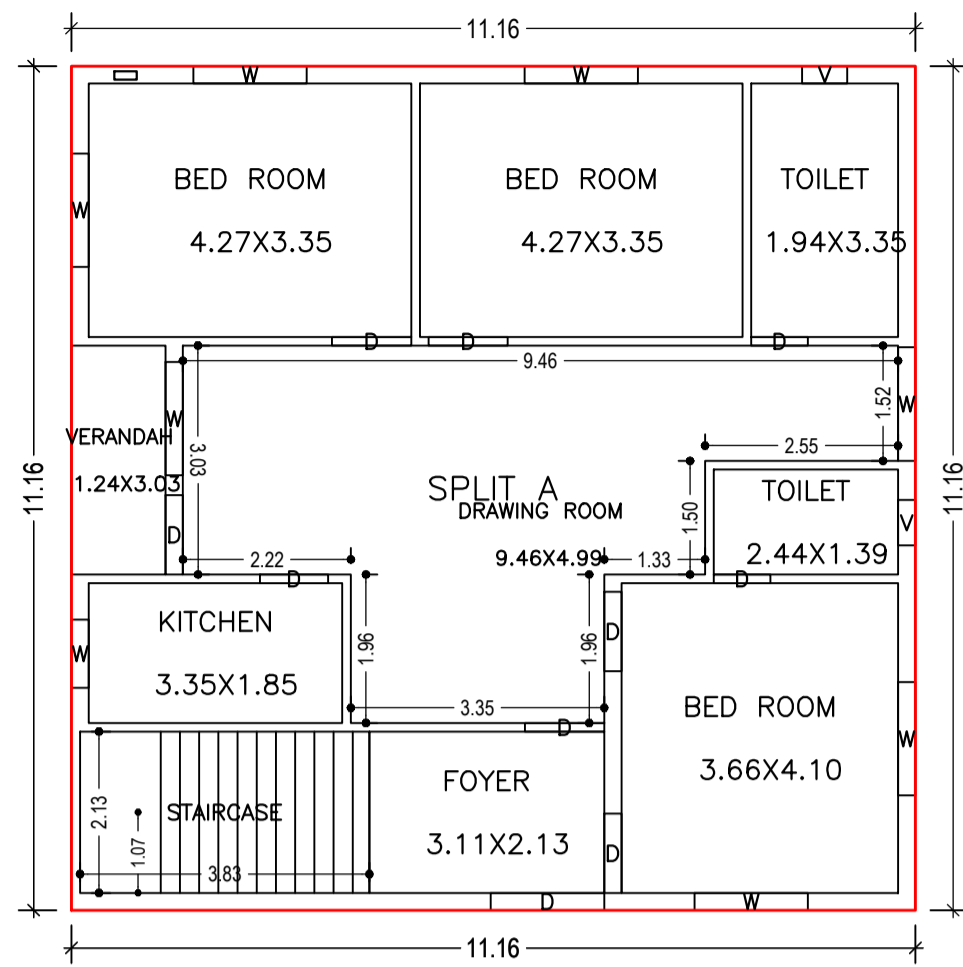

GROUND FLOOR PLAN
(Proposed)
(SCALE 1:100)

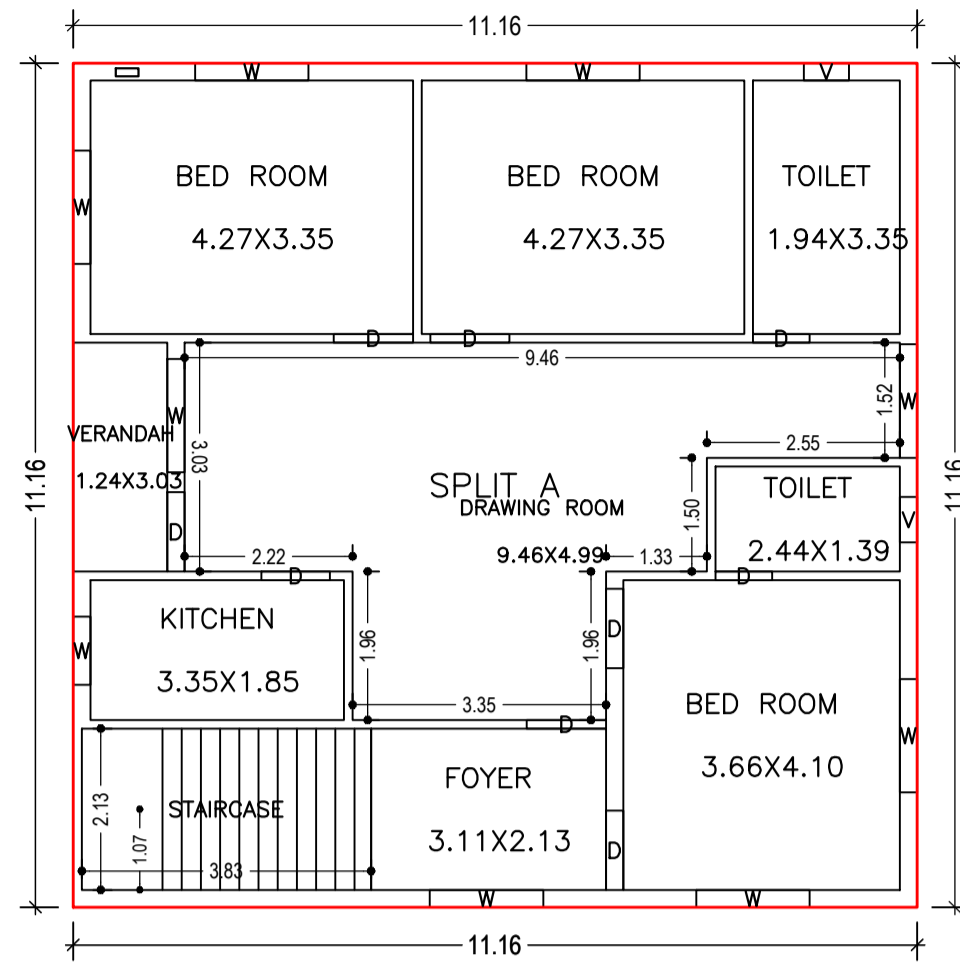

FIRST FLOOR PLAN
(Proposed)
(SCALE 1:100)

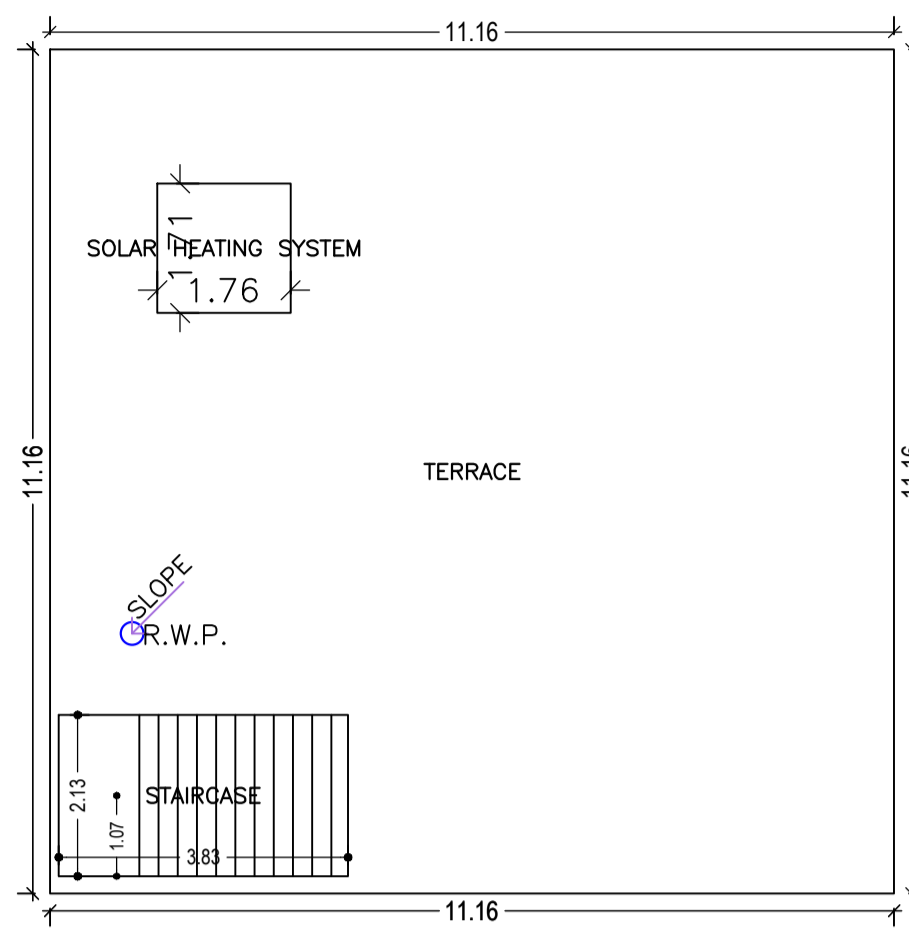

TERRACE FLOOR PLAN
(SCALE 1:100)

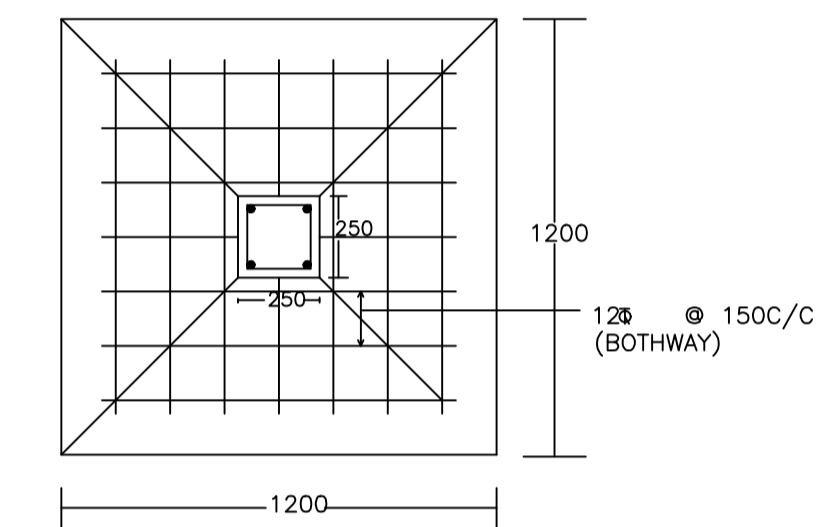
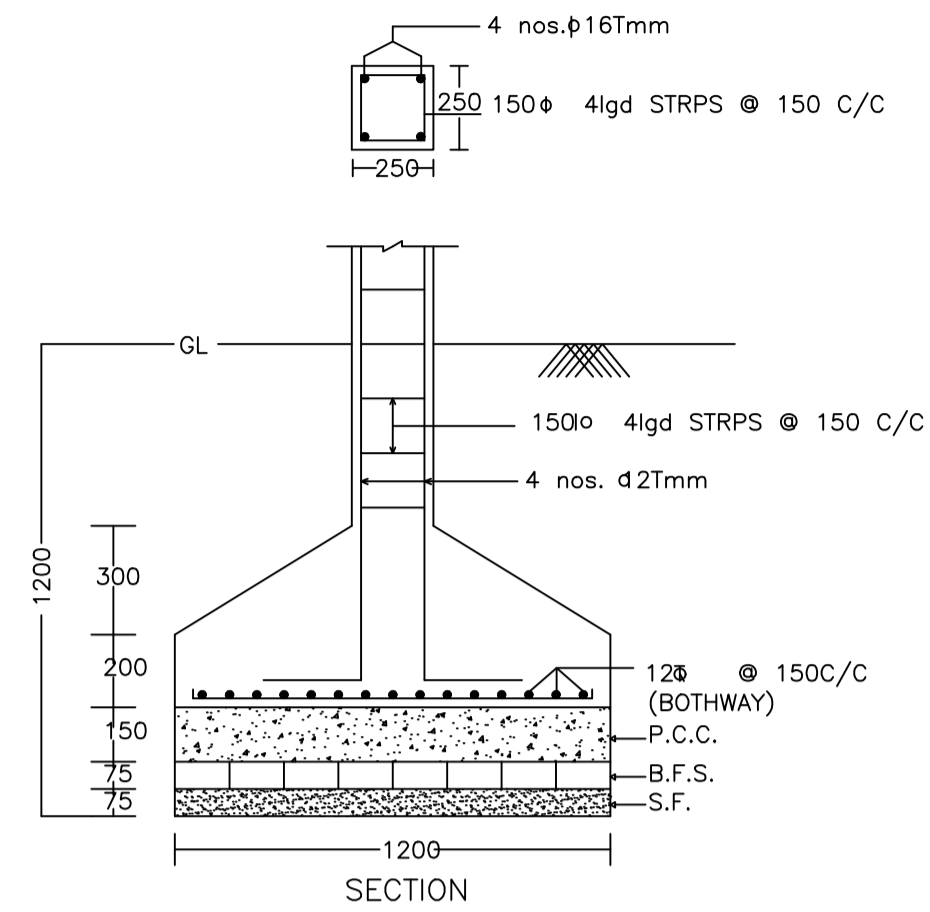

DETAIL OF COLUMNS

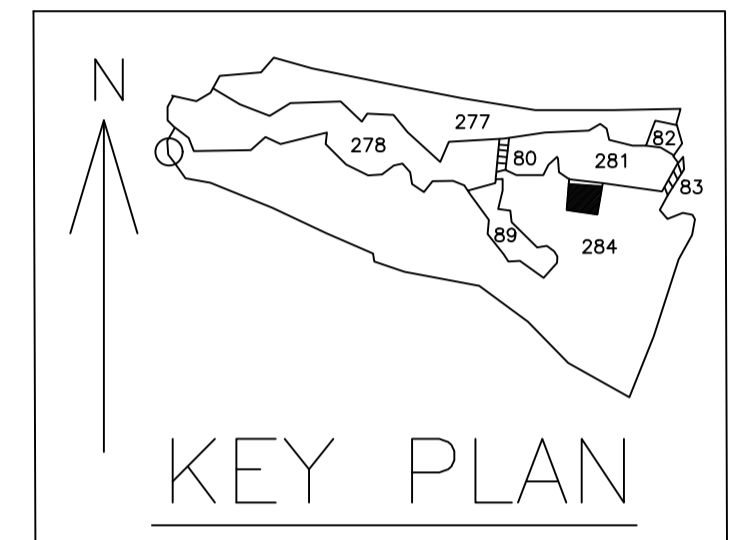

KEY PLAN

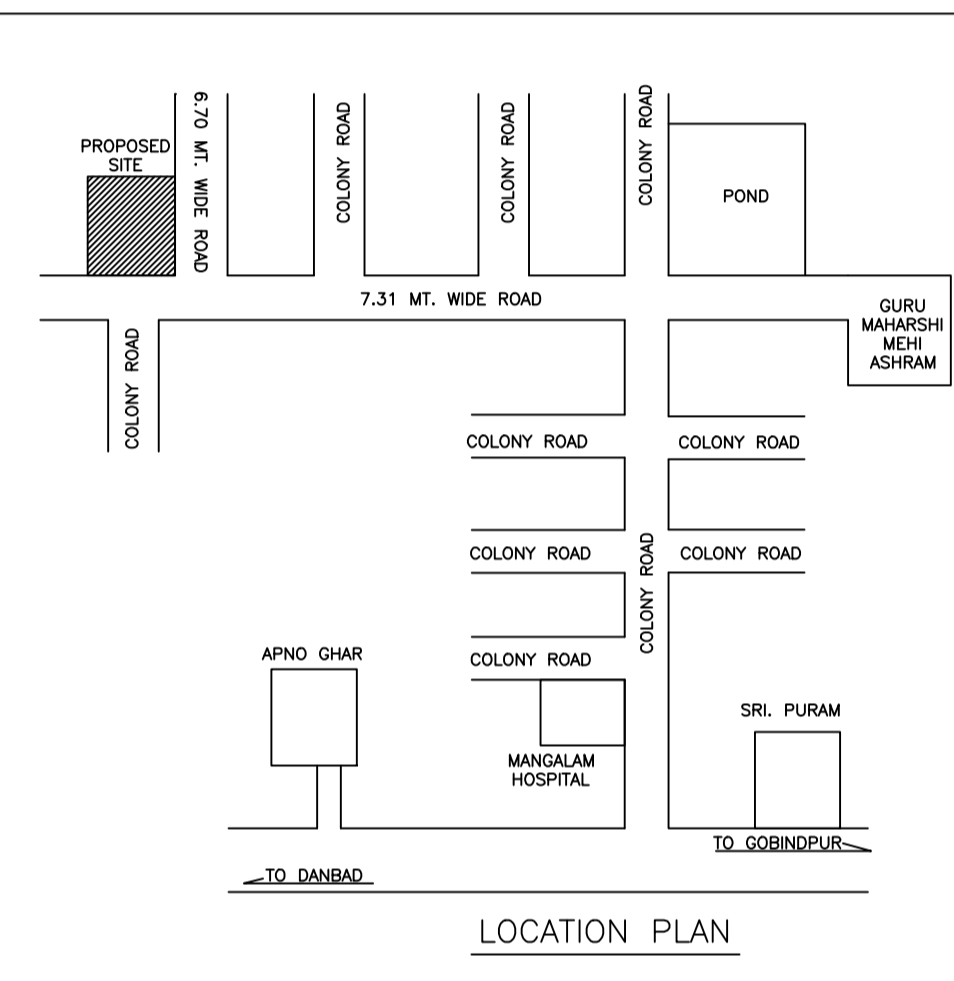

LOCATION PLAN

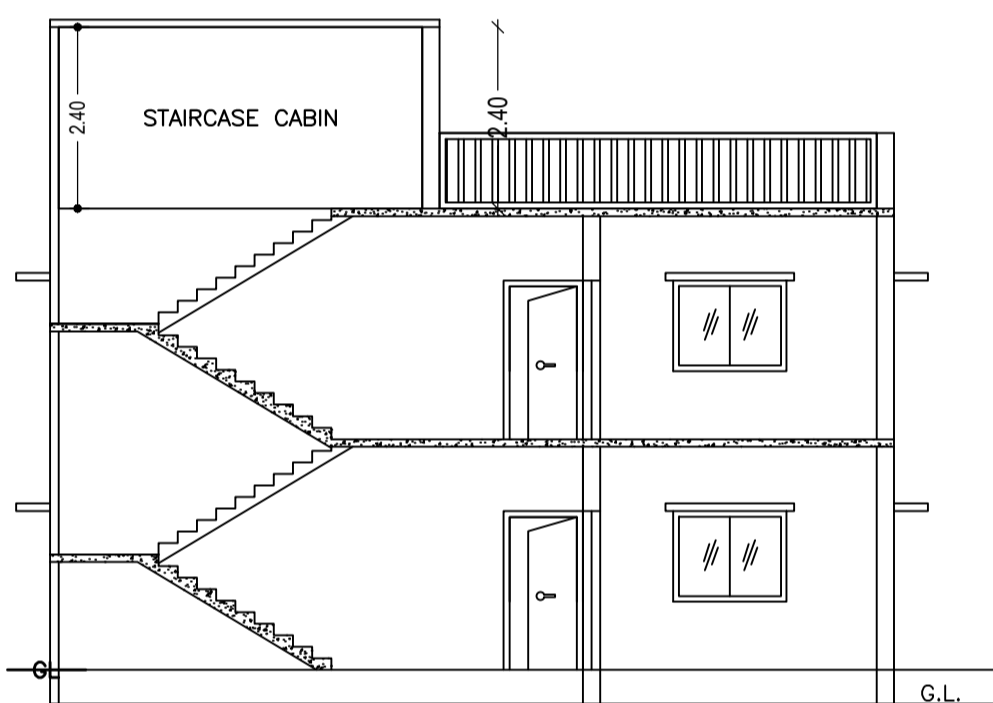

SECTION ON X-X

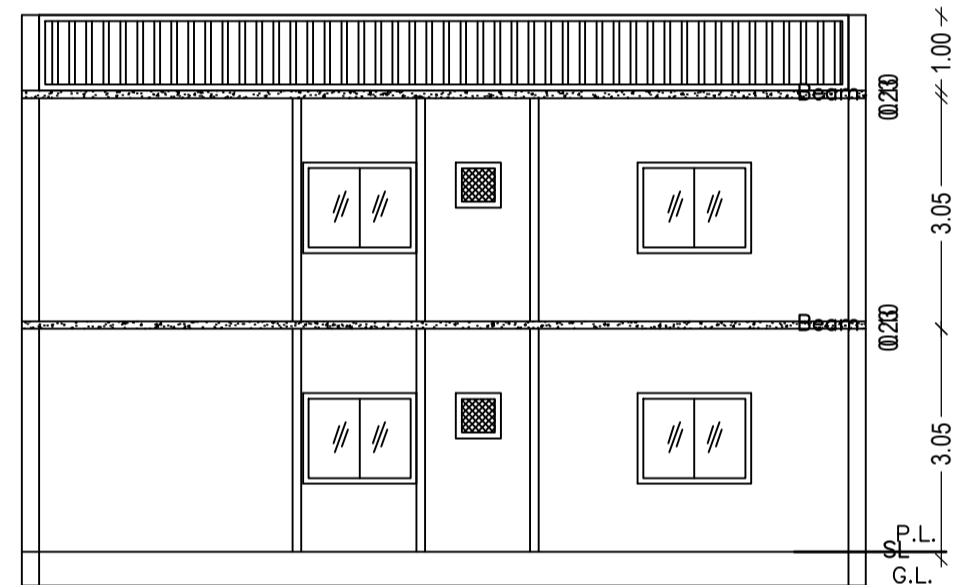

SECTION ON Y-Y

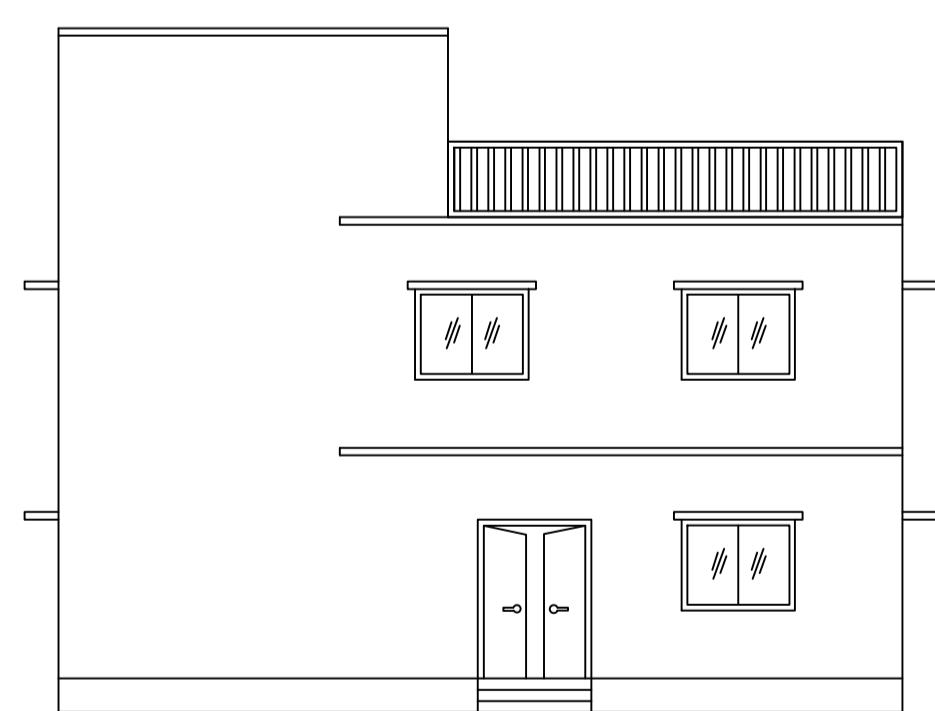

FRONT ELEVATION

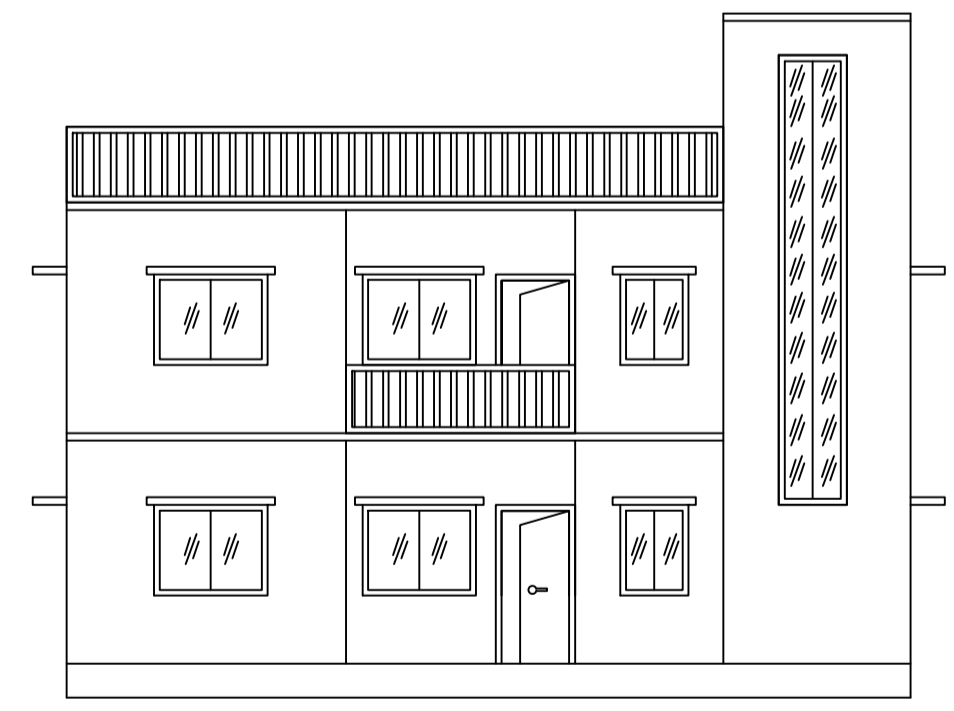

LEFT SIDE ELEVATION

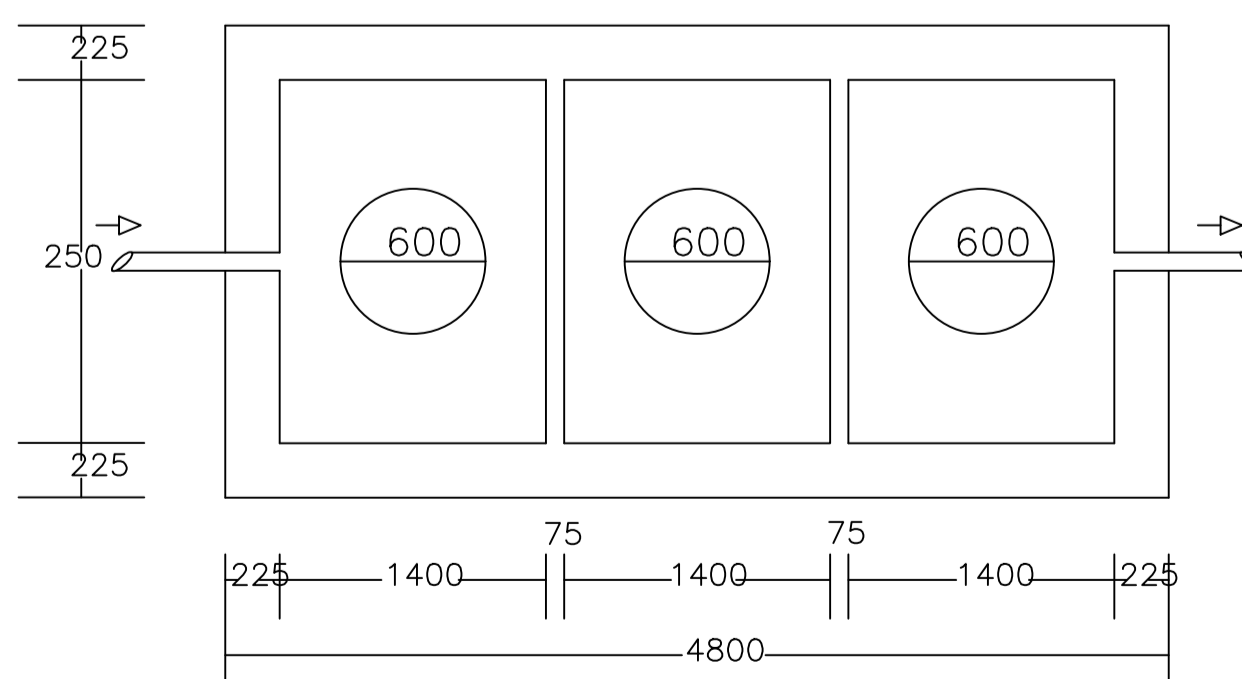
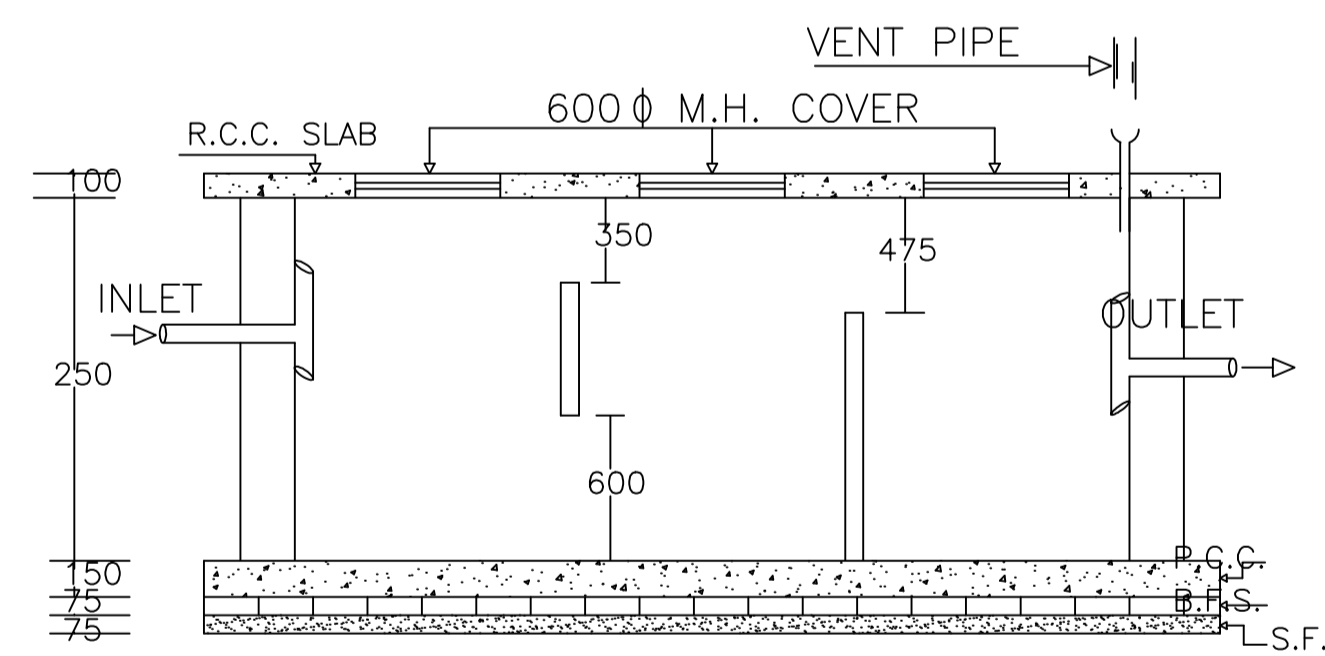

PLAN OF SEPTIC TANK

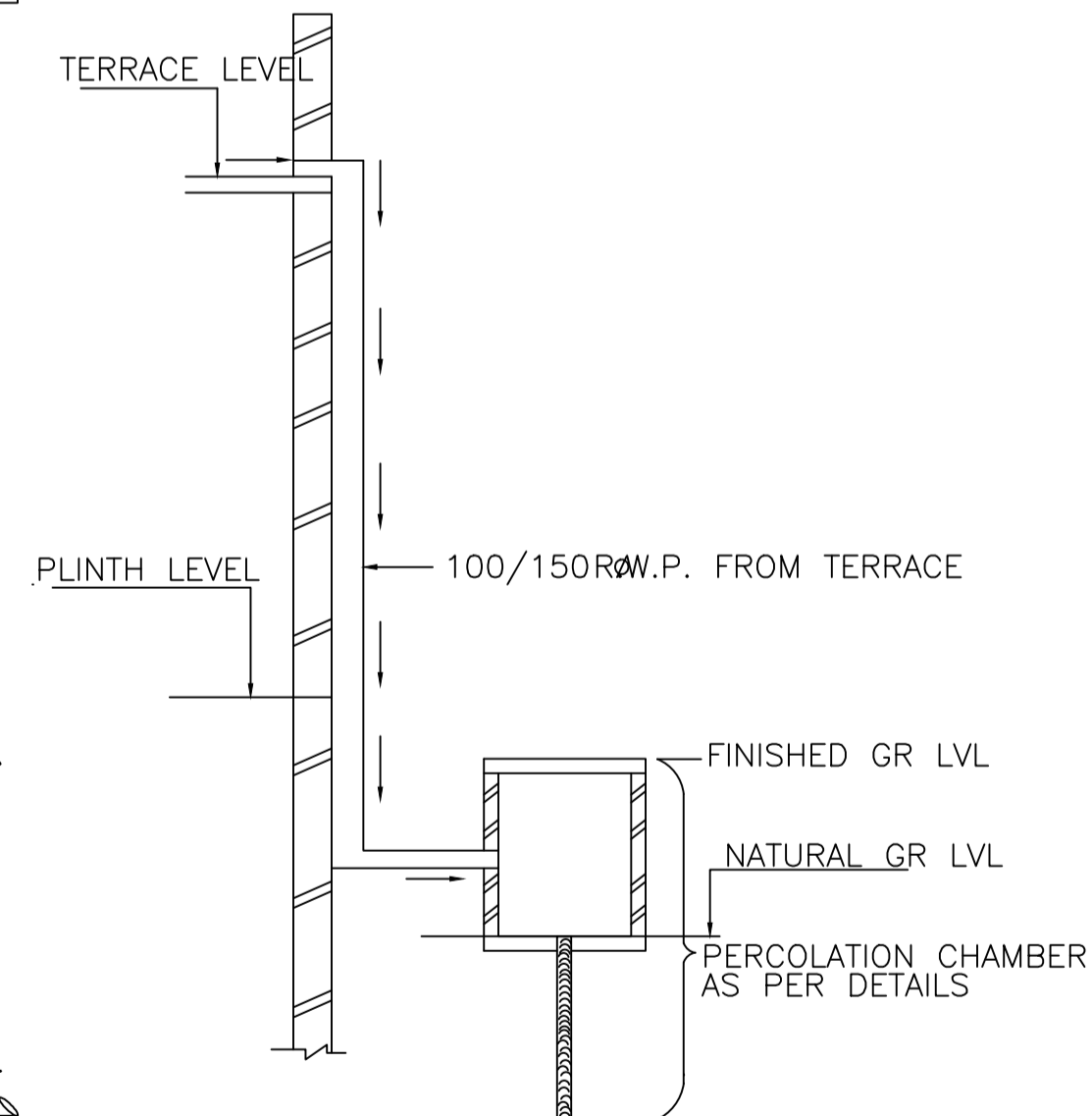

ROOF TOP RAIN WATER
COLLECTION SYSTEM

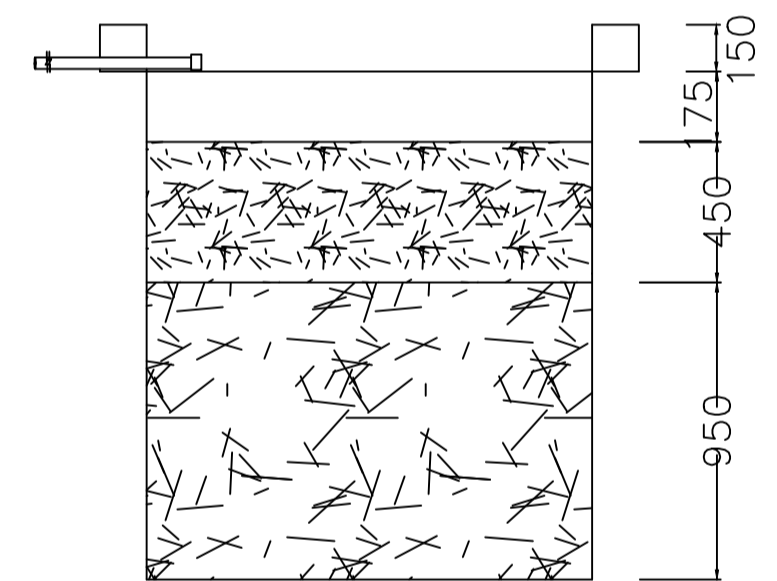

SECTION AT Y-Y

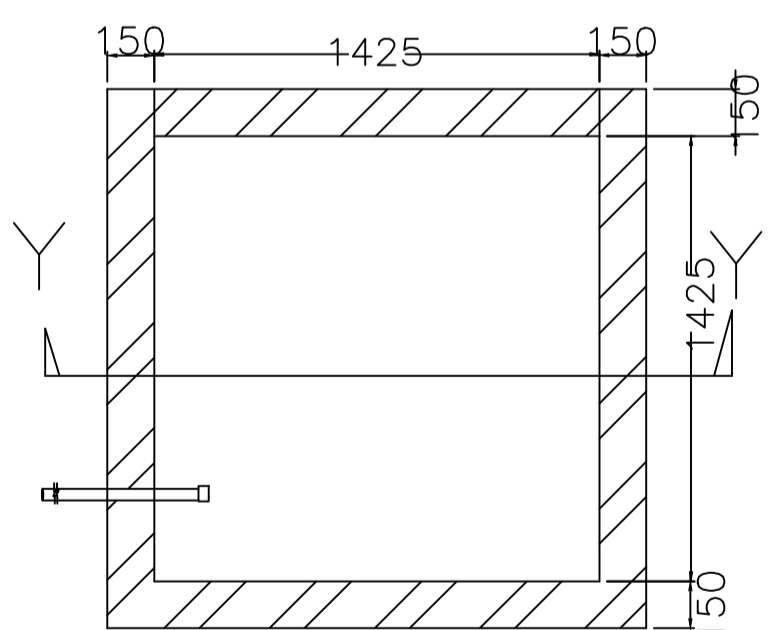

PLAN OF RECHARGE WELL
WATER HARVESTING

LTP NAME AND SIGNATURE	STRUCTURAL ENG'S NAME AND SIGNATURE	BUILDER NAME AND SIGNATURE	DIGITAL SIGNATURE
SANJEEV KUMAR RAY MADA/ENG/0021/2019			