

Project Title :RITA DEVI

AREA STATEMENT MINERAL AREA DEVELOPMENT	VERSION NO. 1.0.32
AUTHORITY	VERSION DATE: 16/10/2020
PROJECT DETAIL	
Insert No. :	Plot Use - Residential
Region : JHARKHAND URBAN LOCAL BODIES	Plot Sub Use - Bungalow Dwelling / Non Apartment
District : SPHANSIBAD	Land Use Zone - NA
Application Type - General Proposal	Abutting Road Width -
Project Type - Building Permission	Plot No. -
Nature of Development - New	Reference Survey No/Survey No -
Location - DM Area	Thana No. -
SUB Location - NA	Holding No. -
Ward No. -	Khata No. -
North -	North -
South -	South -
East -	East -
West -	West -

AREA OF PLOTS	SQ. MT.
AREA OF PLOT (Minimum)	(A)
Net Plot Area (Gross Plot Area - Deduction from Gross Plot Area)	159.06
Deductions for Balance Plot Area (from Gross Plot Area)	
CGP Area	31.27
Balance Plot Area (Net Plot Area - Recreational/Amenity space)	127.79
Plot Area for Coverage (Net Plot Area)	127.79
Plot Area for FSI (Net Plot Area + Road/Watering Area)	159.06
COVERAGE CHECK	
Proposed Coverage Area (30.56 %)	78.74
Total Coverage Area (30.56 %)	78.74
FAR CHECK:	
Proposed Area of FAR	157.48
Total Area of FAR	157.48
BUILD UP AREA CHECK	
Total Proposed Buildup Area	157.48
ARCHITECT/SUPERVISOR (Regd)	OWNER
DEVELOPMENT AUTHORITY	LOCAL BODY

FOUNDATION	R.C.C. (1:1.5:3) Column footing foundation.
PLINTH	12"th R.C.C. (1:1.5:3) all round on plinth level.
FLOORING	1.5"th Marble. flooring over 3"th P.C.C. (1:3:6).
SUPER STRUCTURE	First class brick work in cement mortar (1:5).
SLAB,BEAM, stairs & LINTEL	All R.C.C. work (1:1.5:3).
WOOD WORK	All door & window frames of sal wood
PLASTERING	12mm cement plaster (1:6) both side.

COLOR INDEX				
Color Index:	Color	Color	Color	Color
Color Index:	Color	Color	Color	Color
Color Index:	Color	Color	Color	Color
Color Index:	Color	Color	Color	Color

MARGIN DETAIL:					
Building Wing	Road Name	Front Margin	Rear Margin	Side1 Margin	Side2 Margin
A1 (A1)	4.26 M ROAD	0.04	1.97	0.97	0.51

FAR & Tenement Details (Table 4c-1)					
Building	No. of Same Bldg	Total Built Up Area (Sq.mt.)	Proposed FAR Area (Sq.mt.)	Total FAR Area (Sq.mt.)	Tenent (No.)
A1 (A1)	1	157.48	157.48	157.48	01
Grand Total:	1	157.48	157.48	157.48	01

BRIEF SPECIFICATION

FOUNDATION - R.C.C. (1:1.5:3) Column footing foundation.
PLINTH - 12"th R.C.C. (1:1.5:3) all round on plinth level.
FLOORING - 1.5"th Marble. flooring over 3"th P.C.C. (1:3:6).
SUPER STRUCTURE - First class brick work in cement mortar (1:5).
SLAB,BEAM, stairs & LINTEL - All R.C.C. work (1:1.5:3).
WOOD WORK - All door & window frames of sal wood
PLASTERING - 12mm cement plaster (1:6) both side.

SCHEDULE

D1 - 1.07 X 2.13	W - 0.9 X 1.22
D2 - 0.9 X 2.13	W1 - 1.22 X 1.22
D3 - 0.76 X 2.13	W2 - 1.5 X 1.22
CG - 1.22 X 2.13	V - 0.61 X 0.61

SIG. OF OWNER

SIG. OF ENGINEER

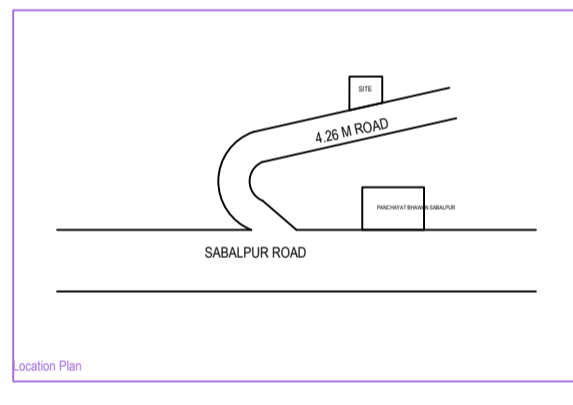
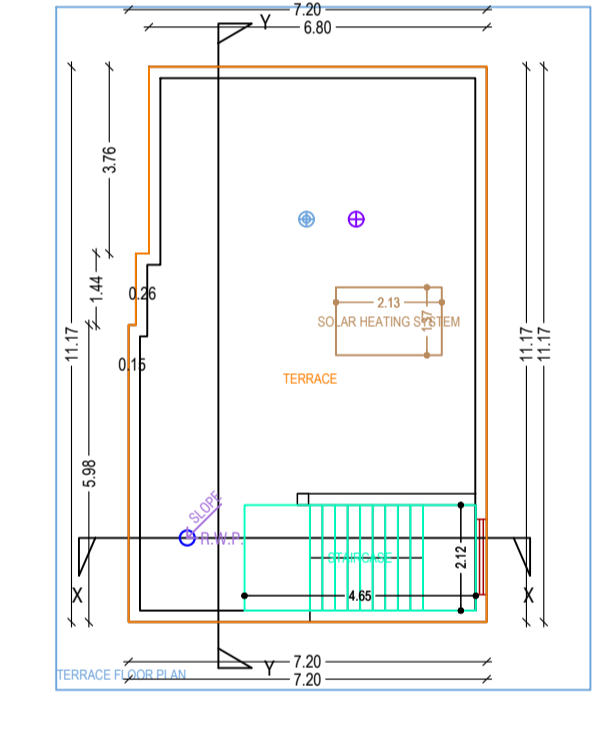
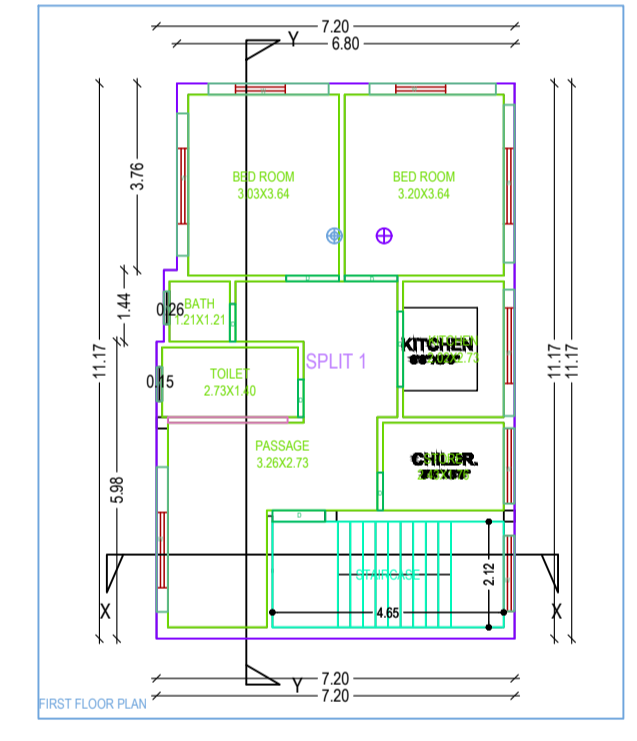
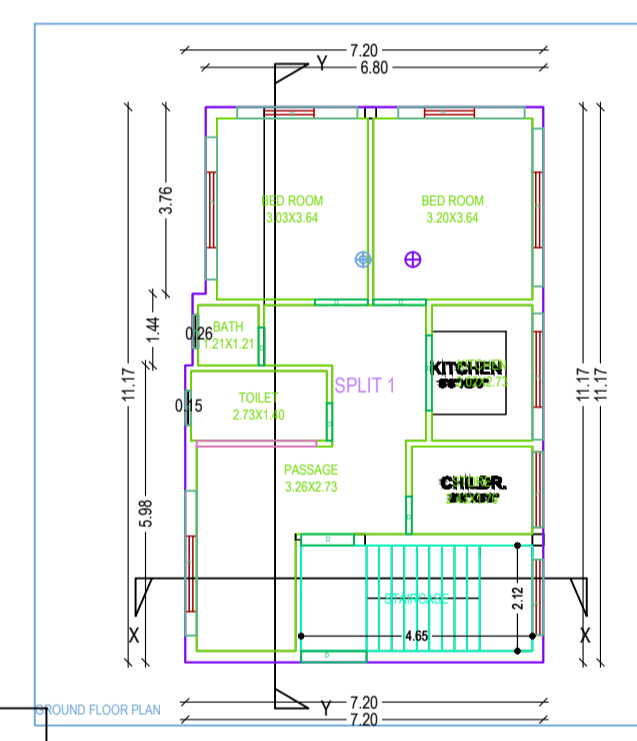
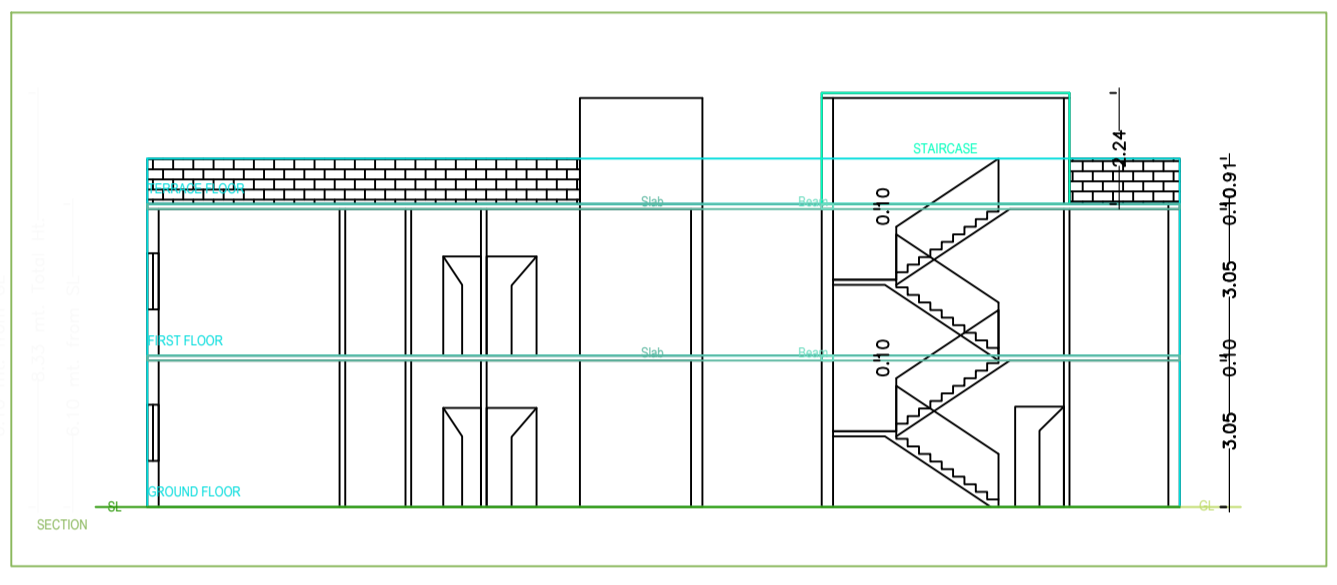
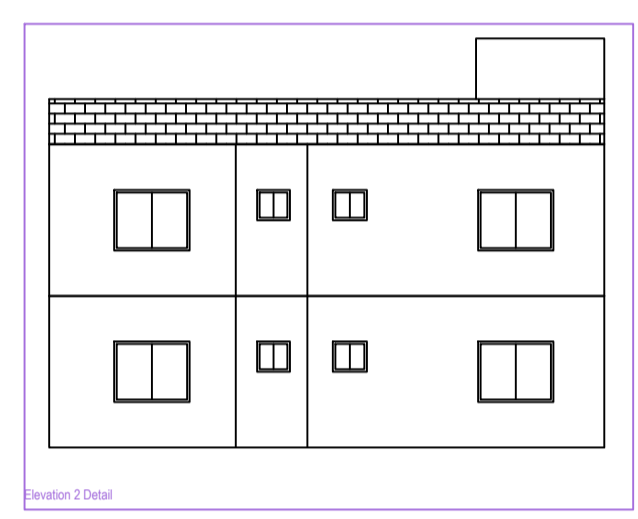
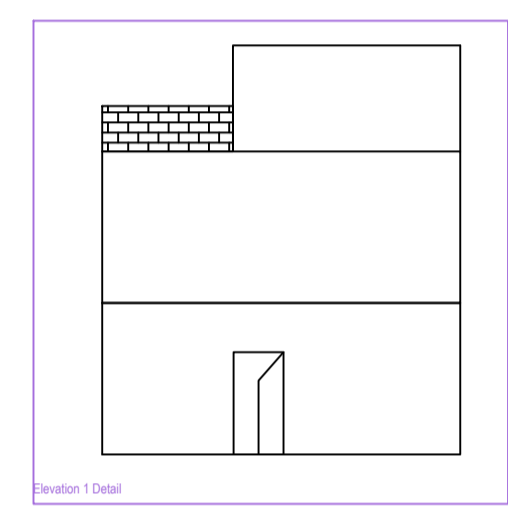
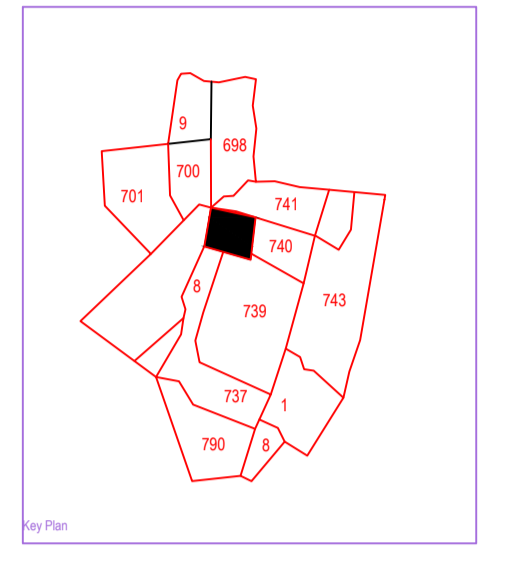
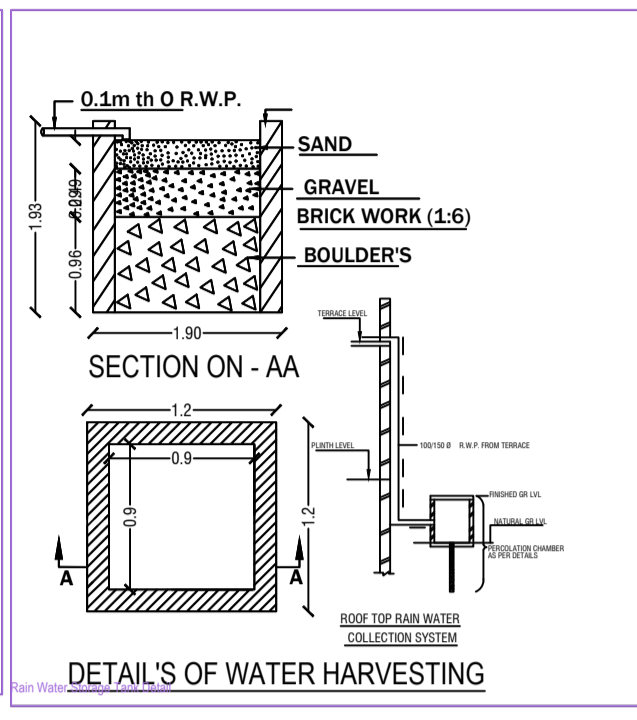
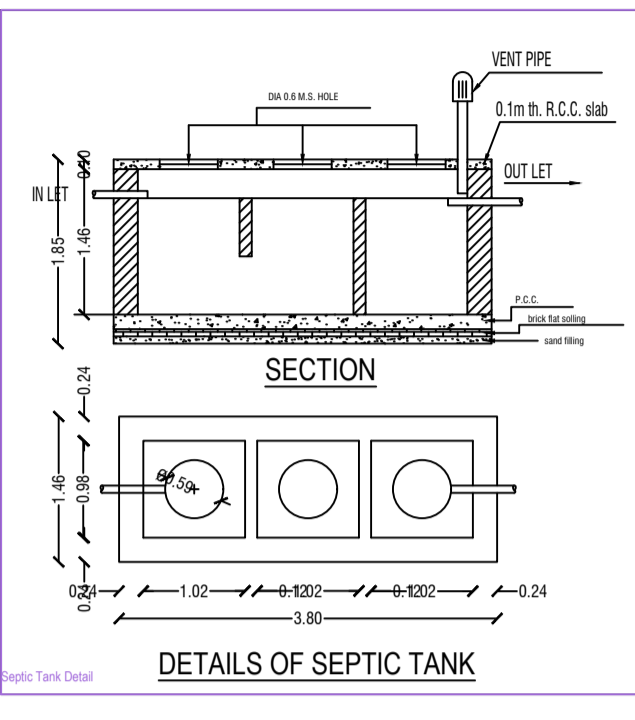
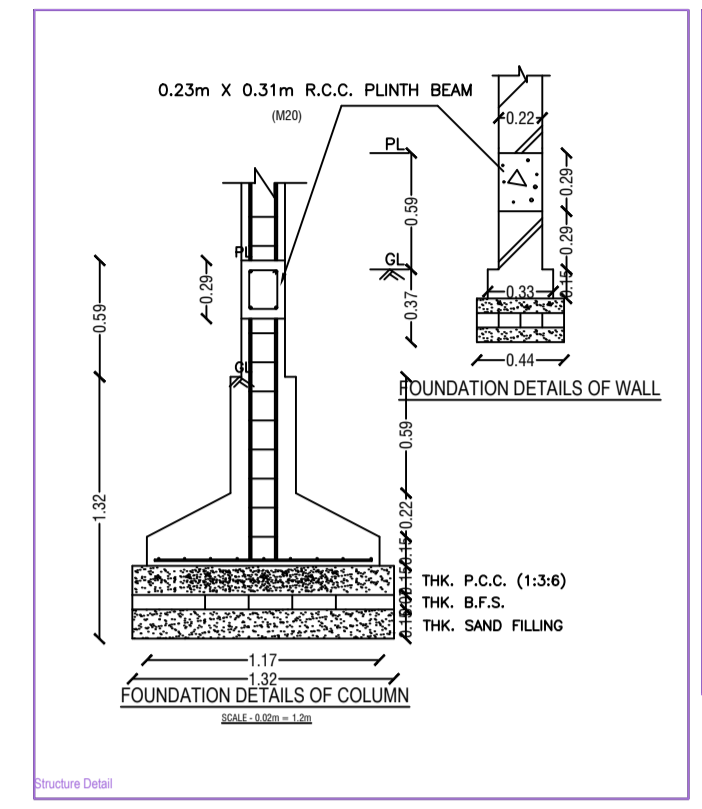
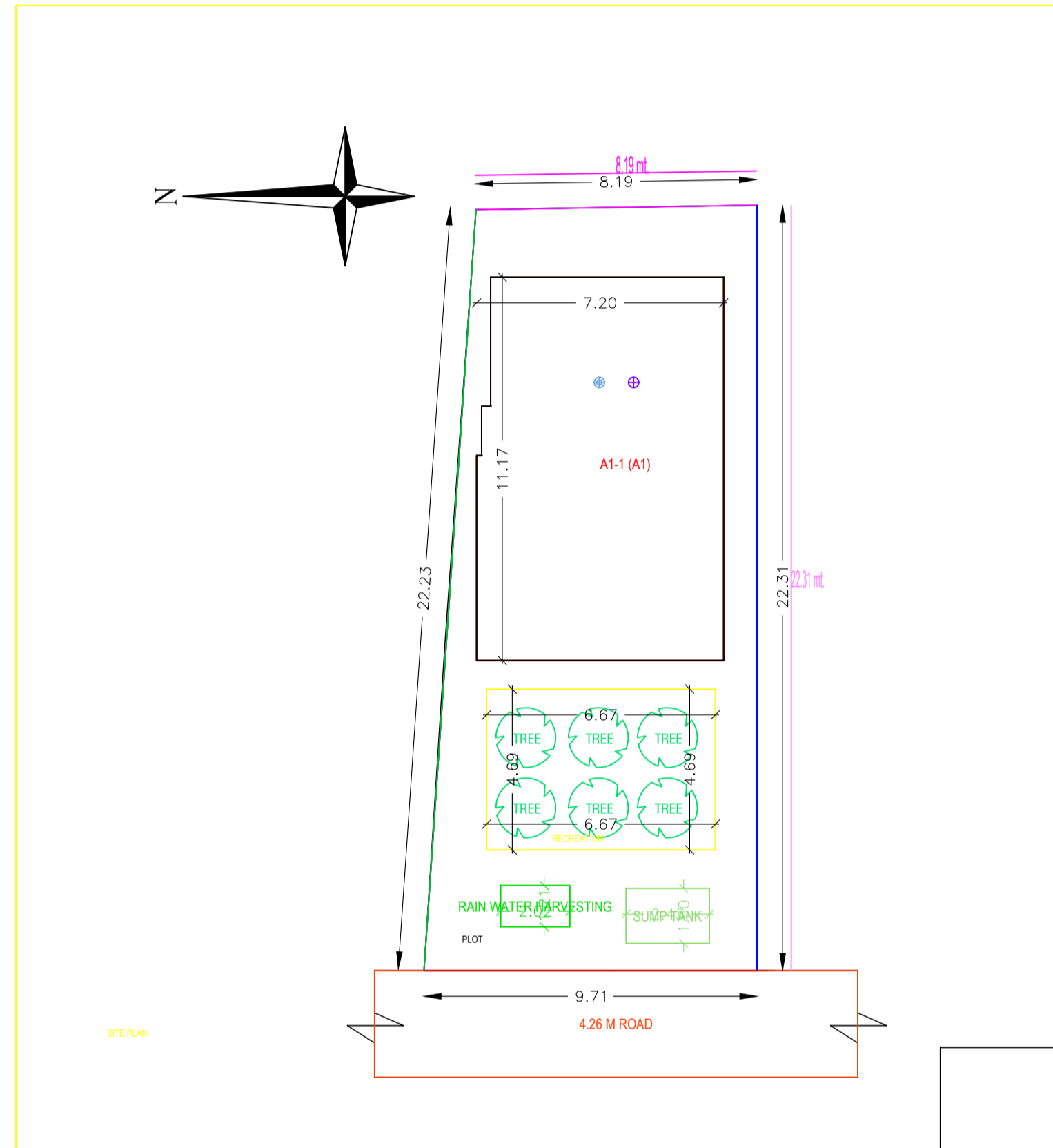

Building :A1 (A1)

Floor Name	Total Built Up Area (Sq.mt.)	Proposed FAR Area (Sq.mt.)	Total FAR Area (Sq.mt.)	Tenent (No.)
Ground Floor	78.74	78.74	78.74	01
First Floor	78.74	78.74	78.74	01
Terraace Floor	0.00	0.00	0.00	00
Total	157.48	157.48	157.48	01
Total Number of Same Buildings	1	-	-	-
Total	157.48	157.48	157.48	01

SCHEDULE OF JOINERY:

BUILDING NAME	NAME	LENGTH	HEIGHT	NOS
A1 (A1)	D	0.76	2.10	06
A1 (A1)	D	1.06	2.10	06
A1 (A1)	D	1.32	2.10	01
A1 (A1)	D	1.52	2.10	02
Total	-	-	-	15

SCHEDULE OF JOINERY:

BUILDING NAME	NAME	LENGTH	HEIGHT	NOS
A1 (A1)	W	0.66	1.20	02
A1 (A1)	W	0.69	1.20	02
A1 (A1)	W	1.52	1.20	04
A1 (A1)	W	2.42	1.20	02
A1 (A1)	W	2.54	1.20	04
A1 (A1)	W	2.96	1.20	02
A1 (A1)	W	2.91	1.20	02
A1 (A1)	W	3.17	1.20	02
Total	-	-	-	20

UnitBUA Table for Building :A1 (A1)

FLOOR	Name	UnitBUA Type	UnitBUA Area	Carpet Area	No. of Rooms	No. of Tenement
GROUND FLOOR PLAN	SPLIT 1	PLAT	157.48	156.94	7	1
Total	-	-	157.48	156.94	14	1