

Project Title - BABLU KUMAR SAW

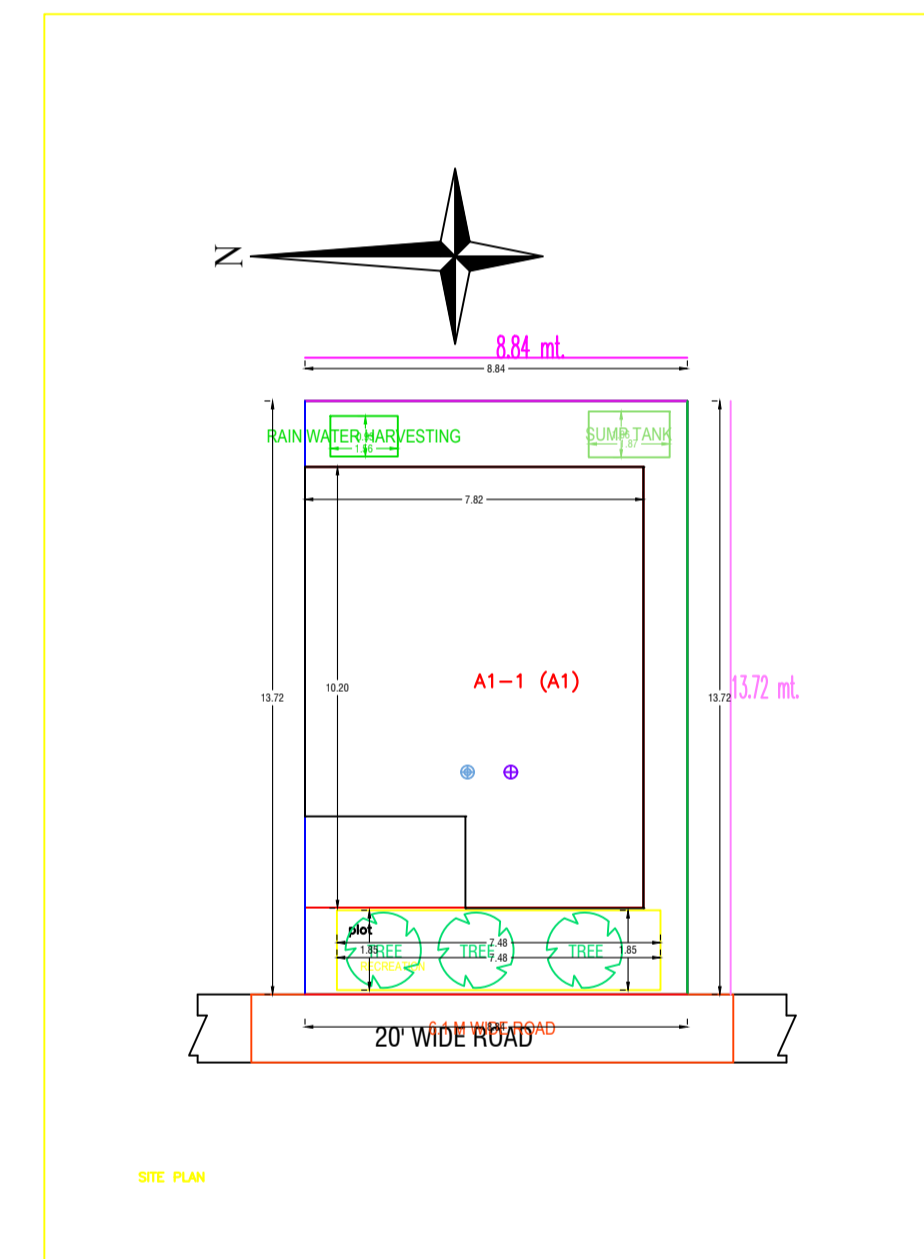
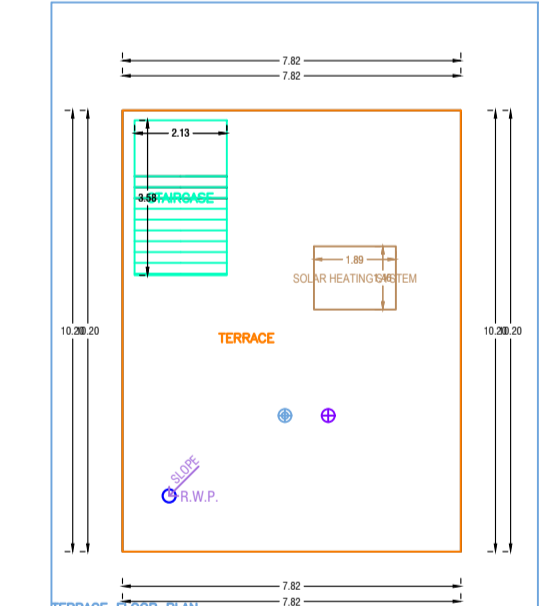
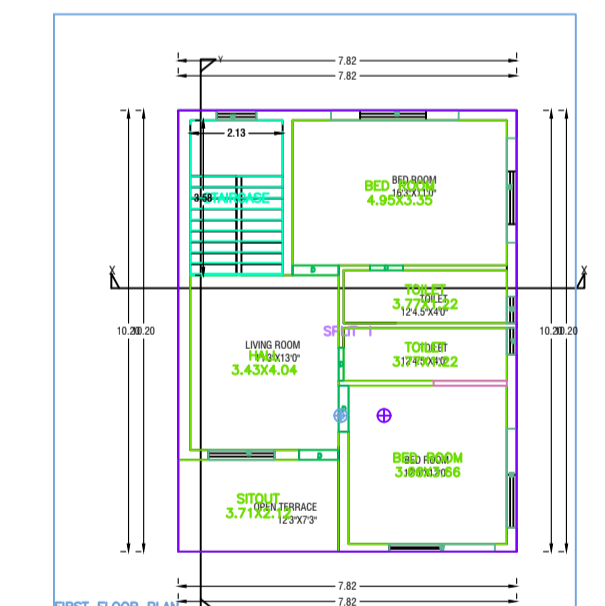
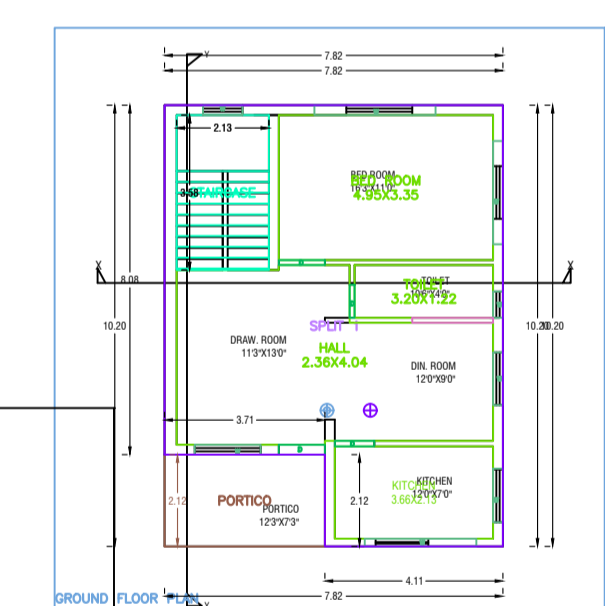
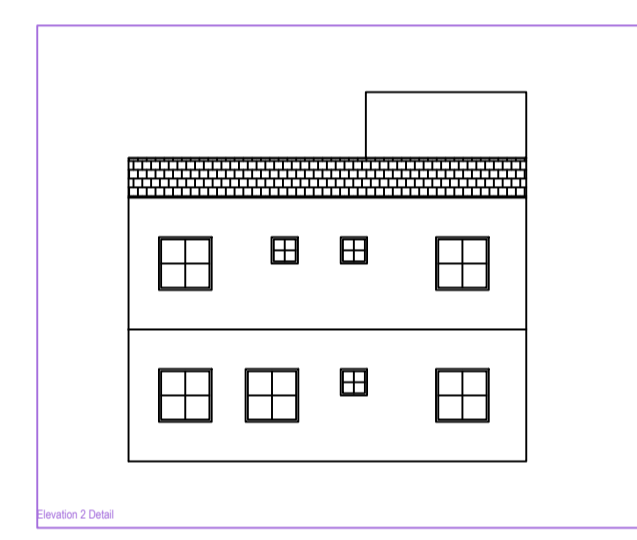
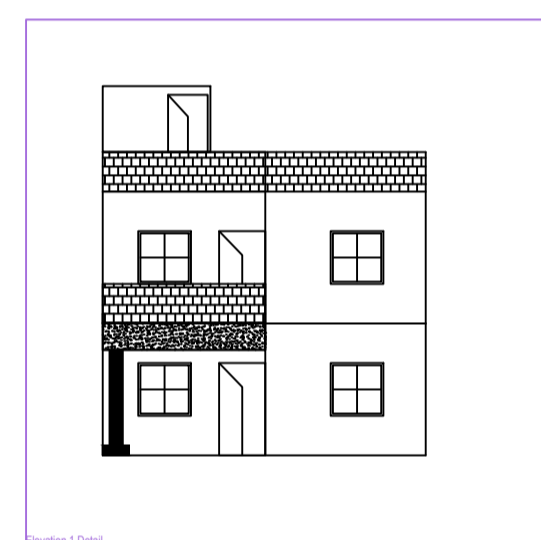
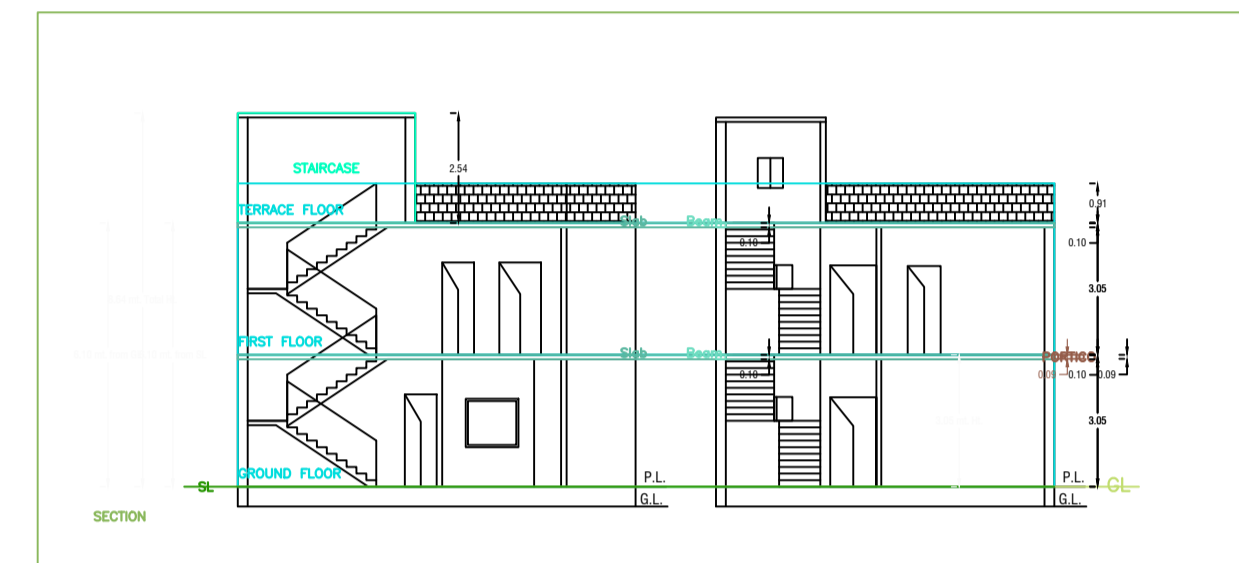
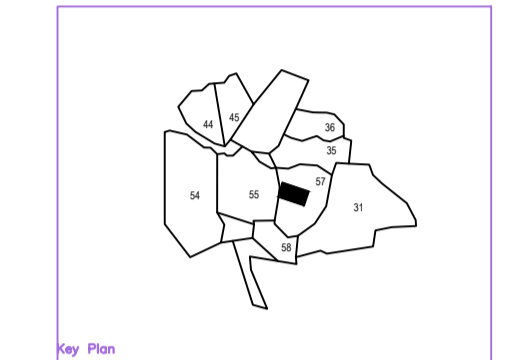
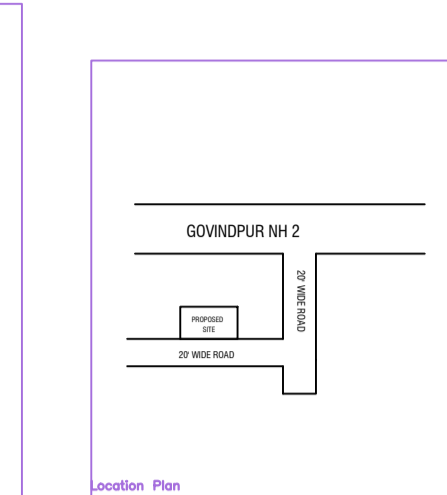
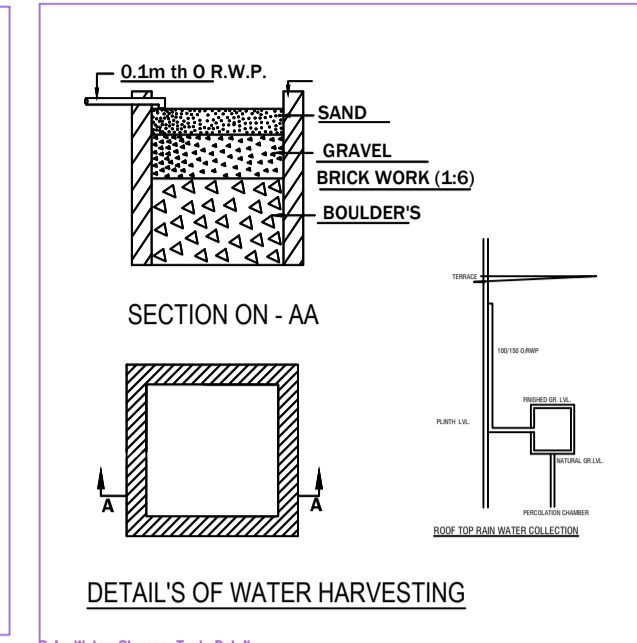
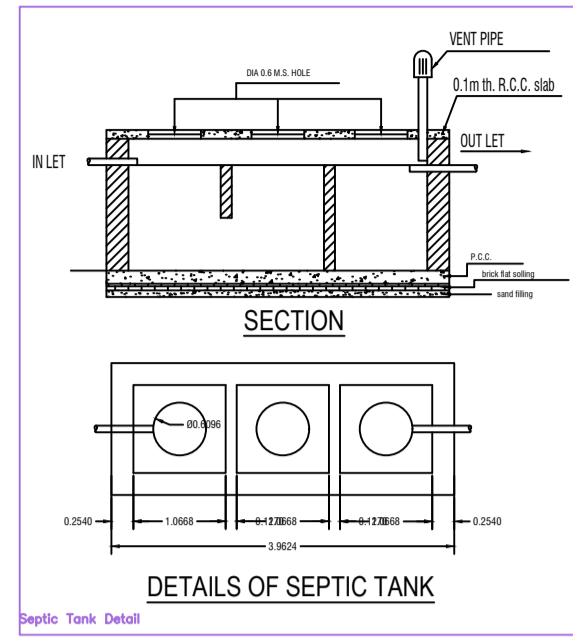
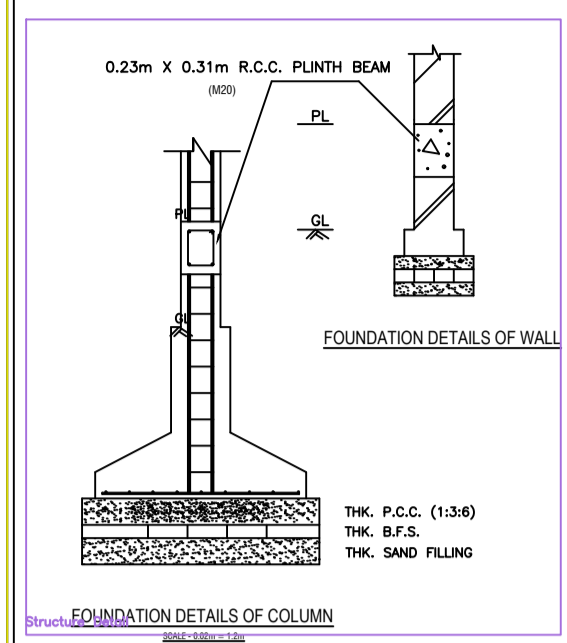

BRIEF SPECIFICATION

FOUNDATION :- R.C.C. (1:1.5:3) Column footing foundation.
PLINTH :- 12"th R.C.C. (1:1.5:3) all round on plinth level.
FLOORING :- 1.5"th Marble flooring over 3"th P.C.C. (1:3:6).
SUPER STRUCTURE :- First class brick work in cement mortar (1:6).
SLAB BEAM, stairs & LINTEL :- All R.C.C. work (1:1.5:3).
WOOD WORK :- All door & window frames of sal wood.
PLASTERING :- 12mm cement plaster (1:6) both side.

SCHEDULE

D1 - 1.07 x 2.13	W - 0.9 x 1.22
D2 - 0.9 x 2.13	W1 - 1.22 x 1.22
D3 - 0.76 x 2.13	W2 - 1.5 x 1.22
CG - 1.22 x 2.13	V - 0.61 x 0.61

SIG. OF OWNER

SIG. OF ENGINEER

Building: A1 (A1)

Floor Name	Total Built Up Area (Sq.m)	Setbacks Area (Sq.m)	Proposed FAR Area (Sq.m)	Total FAR Area (Sq.m)	Tent (No.)
Ground Floor	79.78	7.88	71.90	71.90	01
First Floor	79.78	0.00	79.78	79.78	00
Terrace Floor	0.00	0.00	0.00	0.00	00
Total	159.56	7.88	151.70	151.70	01
Total Number of Same Building	1				
Total	159.56	7.88	151.70	151.70	01

SCHEDULE OF JOINERY:

BUILDING NAME	NAME	LENGTH	HEIGHT	NO.
A1(A1)	D	0.76	2.10	03
A1(A1)	D	0.91	2.10	02
A1(A1)	D	1.07	2.10	04
Total	-	-	-	09

SCHEDULE OF JOINERY:

BUILDING NAME	NAME	LENGTH	HEIGHT	NO.
A1(A1)	W	0.61	1.20	03
A1(A1)	W	0.91	1.20	02
A1(A1)	W	1.22	1.20	01
A1(A1)	W	1.24	1.20	01
A1(A1)	W	1.53	1.20	02
A1(A1)	W	2.28	1.20	01
A1(A1)	W	2.39	1.20	01
A1(A1)	W	2.42	1.20	01
A1(A1)	W	2.44	1.20	01
A1(A1)	W	2.58	1.20	01
A1(A1)	W	2.59	1.20	01
A1(A1)	W	2.59	1.20	01
Total	-	-	-	18

UNBILUA Table for building: A1 (A1)

FLOOR	Name	UNBILUA Type	Setback Area	Capal Area	No. of Rooms	No. of Tenement
GROUND FLOOR	SP-1	PLAT	151.70	151.20	4	1
Total	-	-	151.70	151.20	10	1

AREA STATEMENT: URBAN AREA DEVELOPMENT

PROJECT DETAIL	VERSION NO.	VERSION DATE
Project Name	1.0.35	10/10/2020
Project Location	Plot No.	10/10/2020
Project Type	Plot Size	10/10/2020
Project Status	Plot Use	10/10/2020
Project Owner	Plot Area	10/10/2020
Project Designer	Plot Value	10/10/2020
Project Engineer	Plot Price	10/10/2020
Project Surveyor	Plot Rent	10/10/2020
Project Valuer	Plot Tax	10/10/2020
Project Architect	Plot Fee	10/10/2020
Project Contractor	Plot Cost	10/10/2020
Project Material	Plot Profit	10/10/2020
Project Labor	Plot Loss	10/10/2020
Project Other	Plot Net	10/10/2020
Project Total	Plot Gross	10/10/2020

COLOUR INDEX

Color	Index
Red	1
Green	2
Blue	3
Yellow	4
Black	5

Color Index: MARGIN DETAIL

Building Type	Road Name	Front Margin	Rear Margin	Side Margin	Setback Margin
Residential	8.5 m WIDE ROAD	1.50	1.50	0.50	1.00

FAR & Tenement Details (Table 40-1)

Building	No. of Same Bldg	Total Built Up Area (Sq.m)	Setback Area (Sq.m)	Proposed FAR Area (Sq.m)	Total FAR Area (Sq.m)	Tent (No.)
A1 (A1)	1	159.56	7.88	151.70	151.70	01
Total	1	159.56	7.88	151.70	151.70	01

THE PLAN PROPOSED RESIDENTIAL BUILDING OF BABLU KUMAR SAW W/O LATE SAHDEV PRASAD SAW OF GOVINDPUR, DHANBAD ON MOUZA - TILAKRAJDIH NO. 169, OLD KHATA NO. - 10, 15, NEW KHATA NO. - 22, 8, OLD PLOT NO. - 55, 57, NEW PLOT NO. - 83, 84 IN THE DISTRICT OF DHANBAD, JHARKHAND