

SITE PLAN

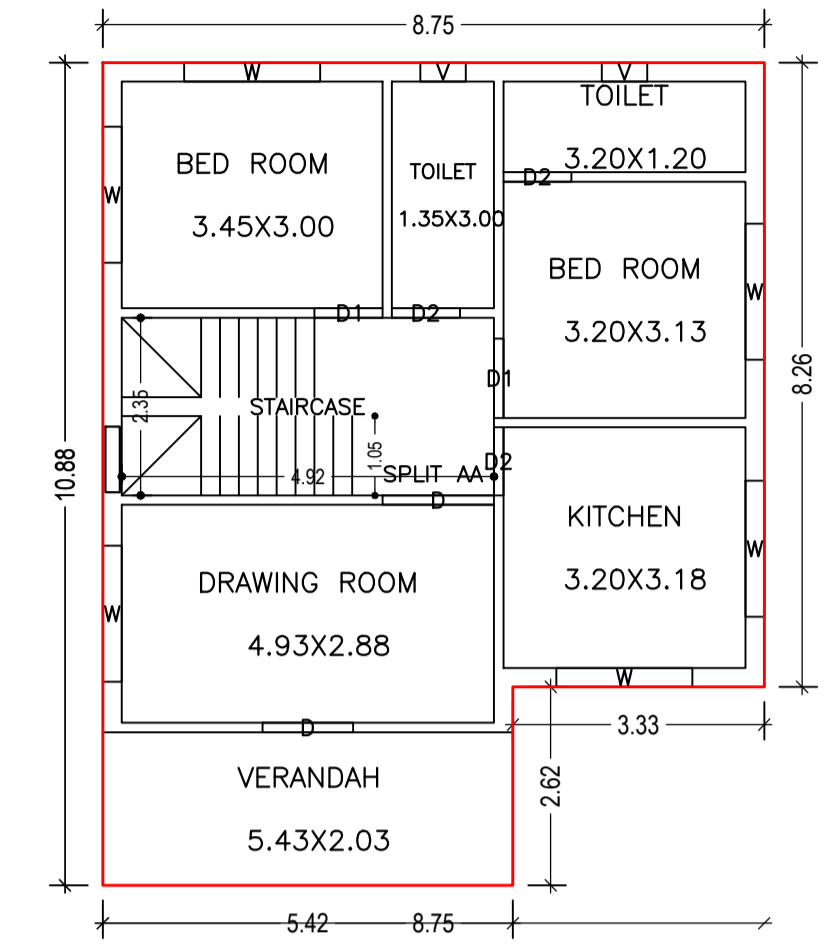

GROUND FLOOR PLAN (Proposed) (SCALE 1:100)

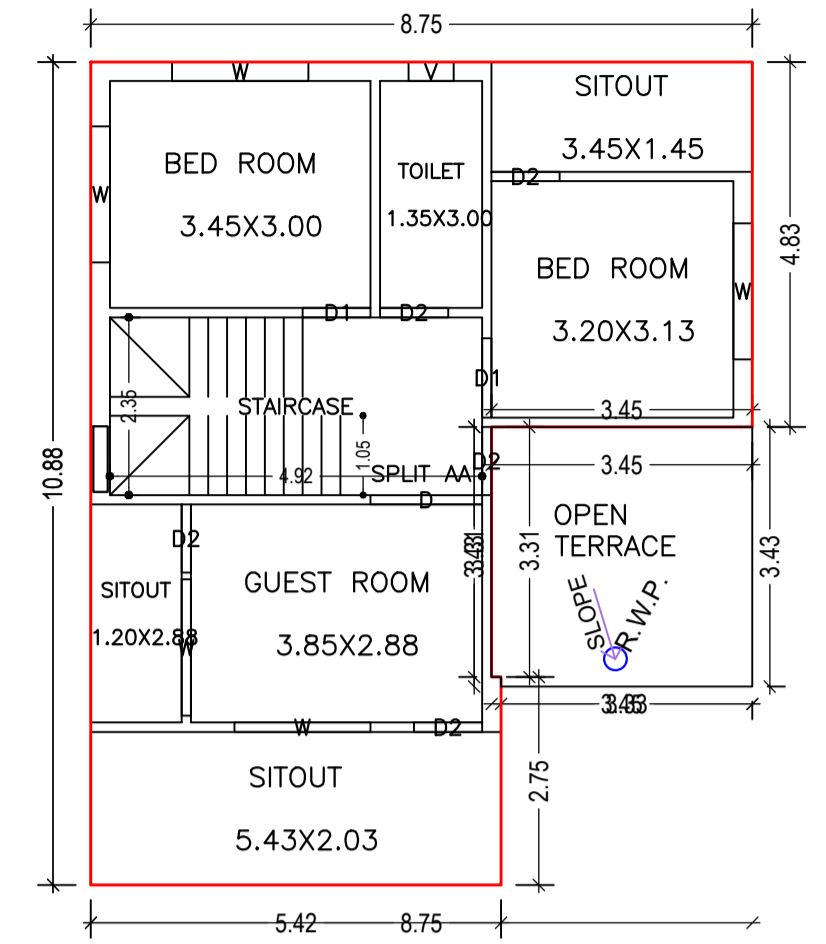

FIRST FLOOR PLAN (Proposed) (SCALE 1:100)

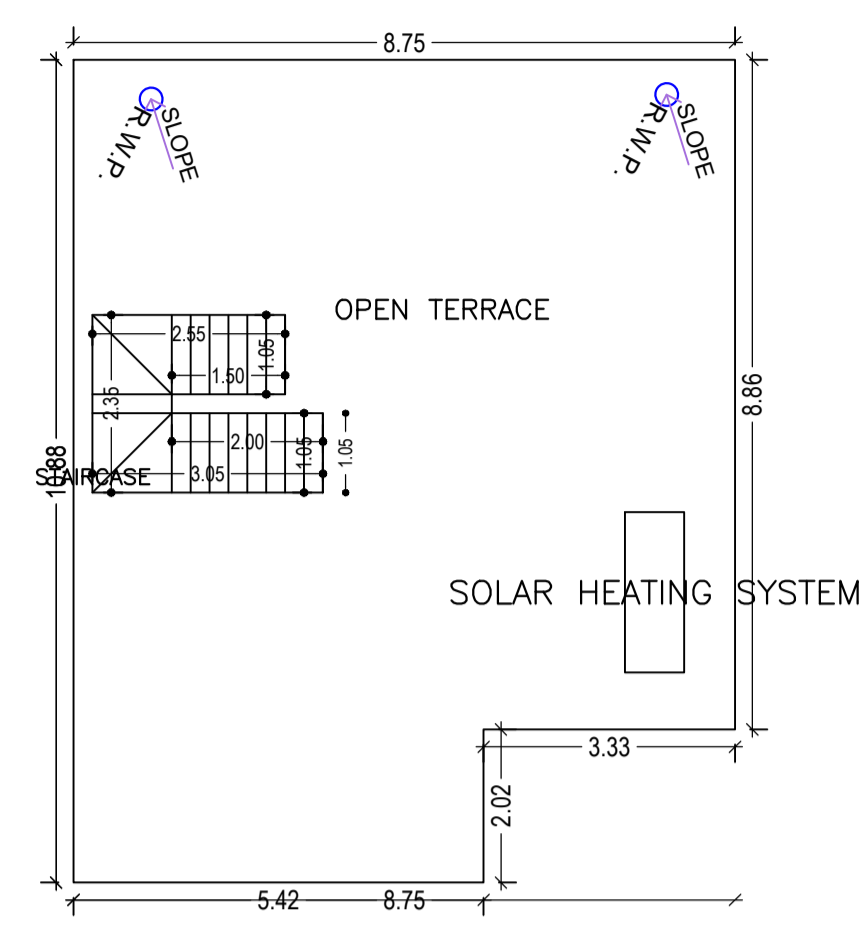

TERRACE FLOOR PLAN (SCALE 1:100)

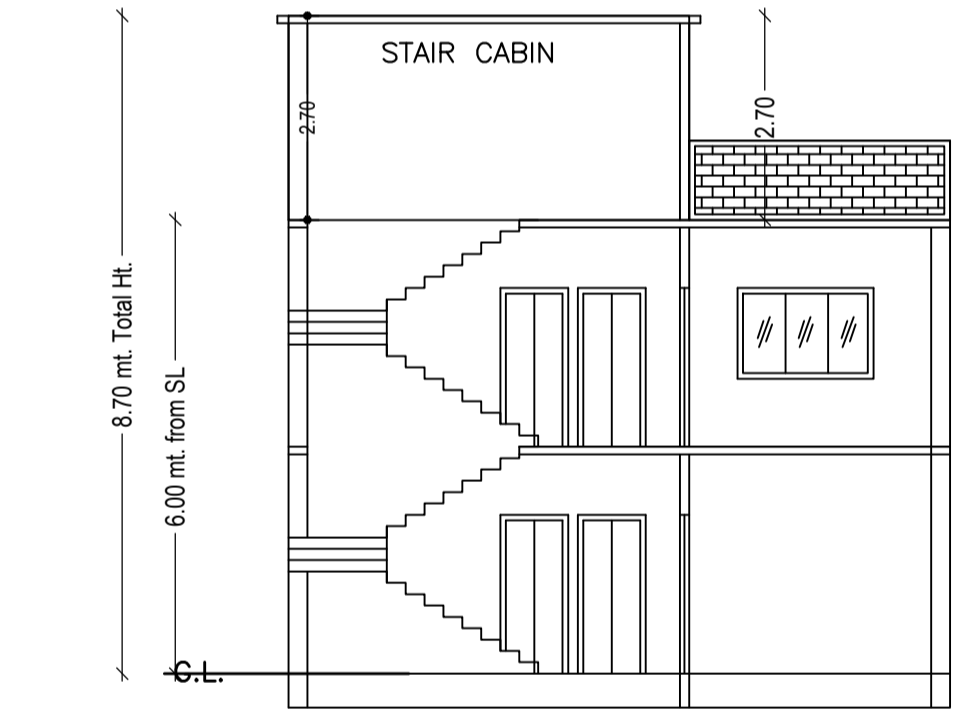

SECTION ON X-X

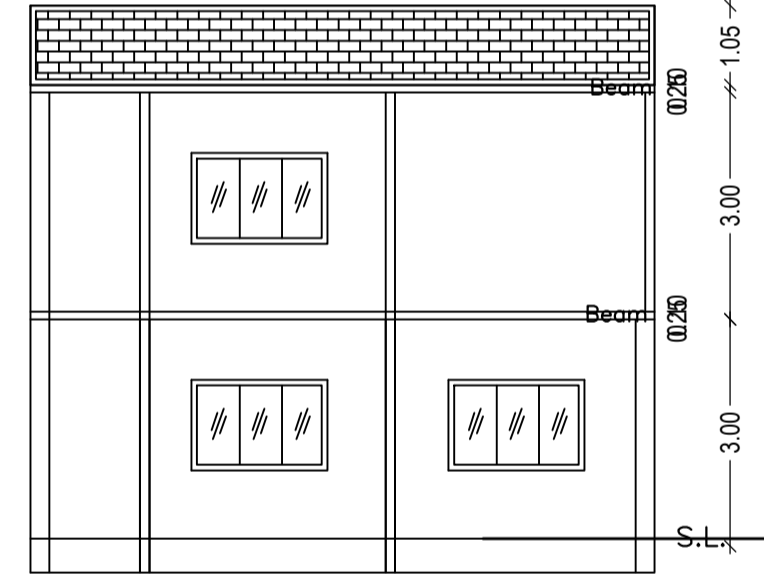

SECTION ON Y-Y

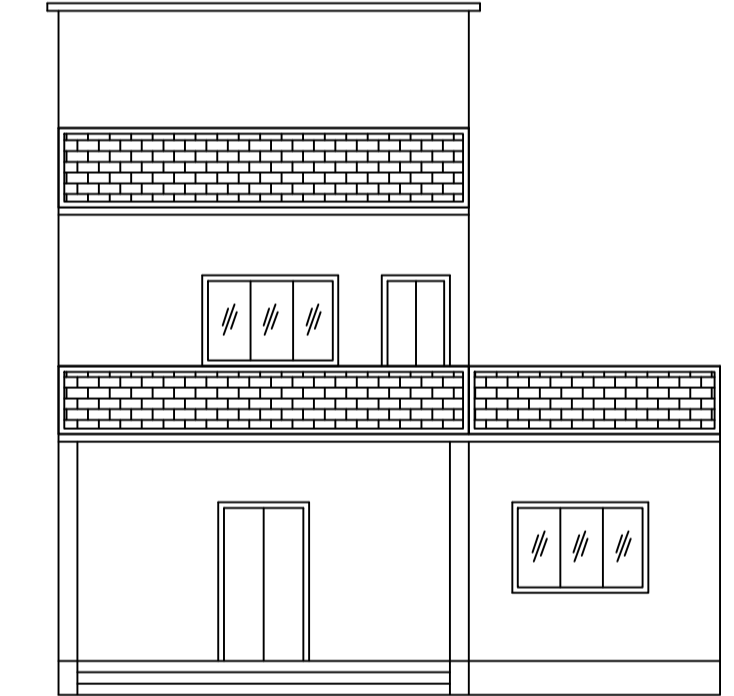

FRONT ELEVATION

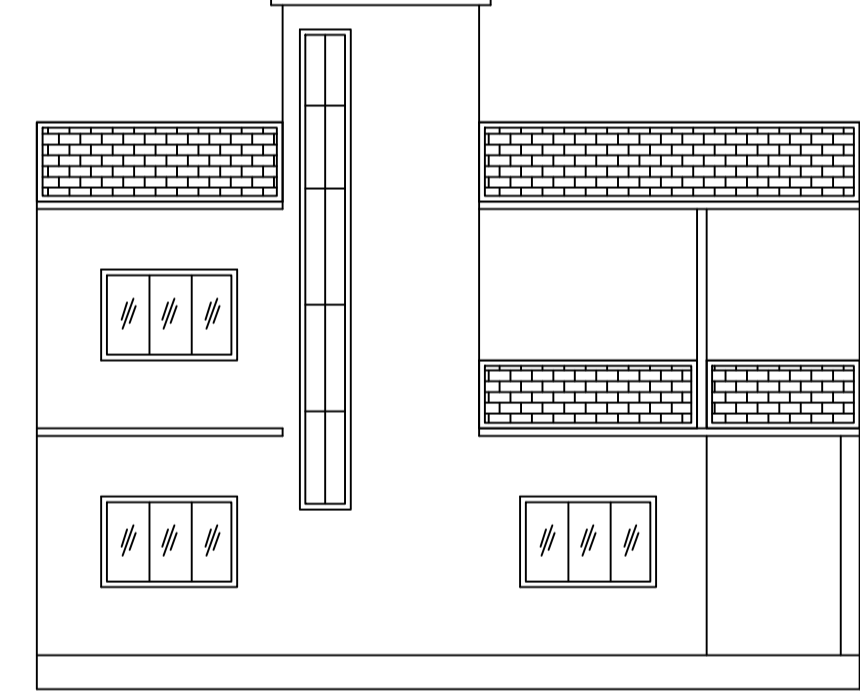

LEFT SIDE ELEVATION

Building :AA (AA)

Floor Name	Total Built Up Area (Sq.mt.)	Proposed FAR Area (Sq.mt.) Resi.	Total FAR Area (Sq.mt.)	Total Consumed Additional FAR Area (Sq.mt.)	Tnmt (No.)
Ground Floor	86.50	86.50	86.50	86.50	01
First Floor	74.67	74.67	74.67	74.67	00
Terrace Floor	0.00	0.00	0.00	0.00	00
Total :	161.17	161.17	161.17	161.17	01
Total Number of Same Buildings	1				
Total :	161.17	161.17	161.17	161.17	01

SCHEDULE OF DOOR:

BUILDING NAME	NAME	LENGTH	HEIGHT	NOS
AA (AA)	D1	0.90	2.10	02
AA (AA)	D2	0.90	2.10	07
AA (AA)	D1	1.05	2.10	02
AA (AA)	D	1.20	2.10	01
AA (AA)	D	1.48	2.10	02

SCHEDULE OF WINDOW/VENTILATION:

BUILDING NAME	NAME	LENGTH	HEIGHT	NOS
AA (AA)	V	0.60	1.20	03
AA (AA)	W	1.80	1.20	11

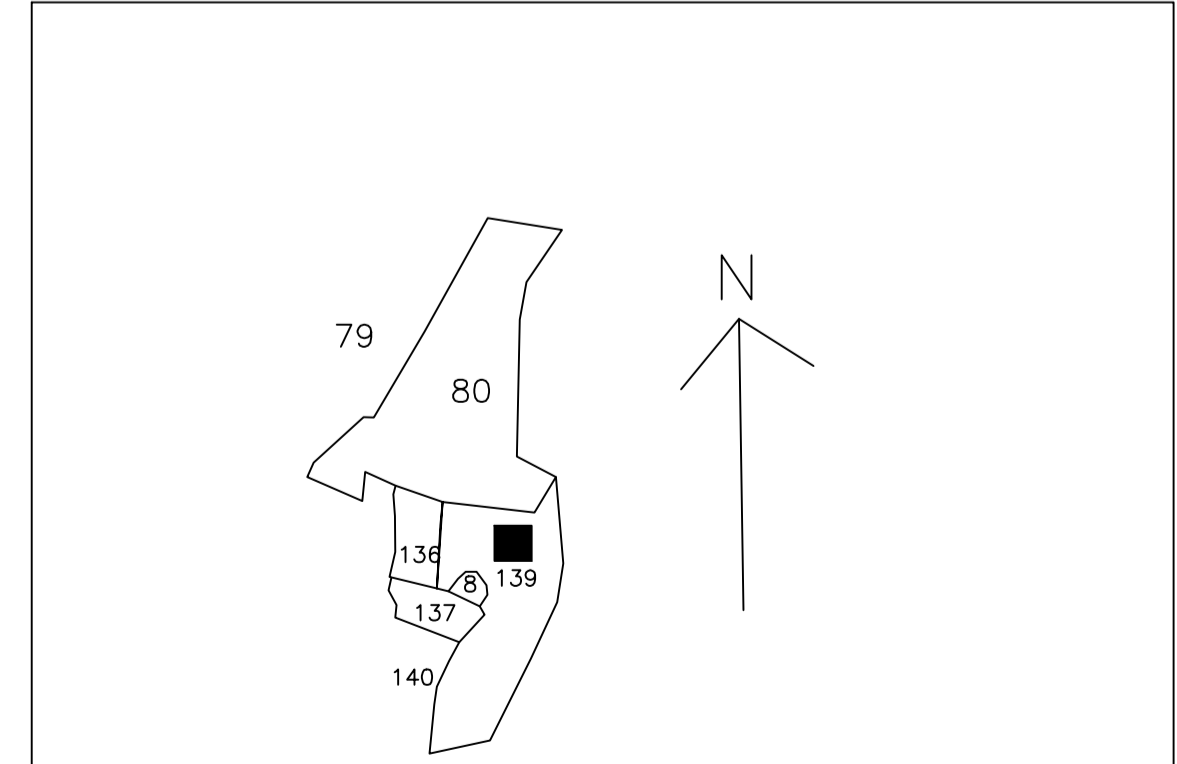
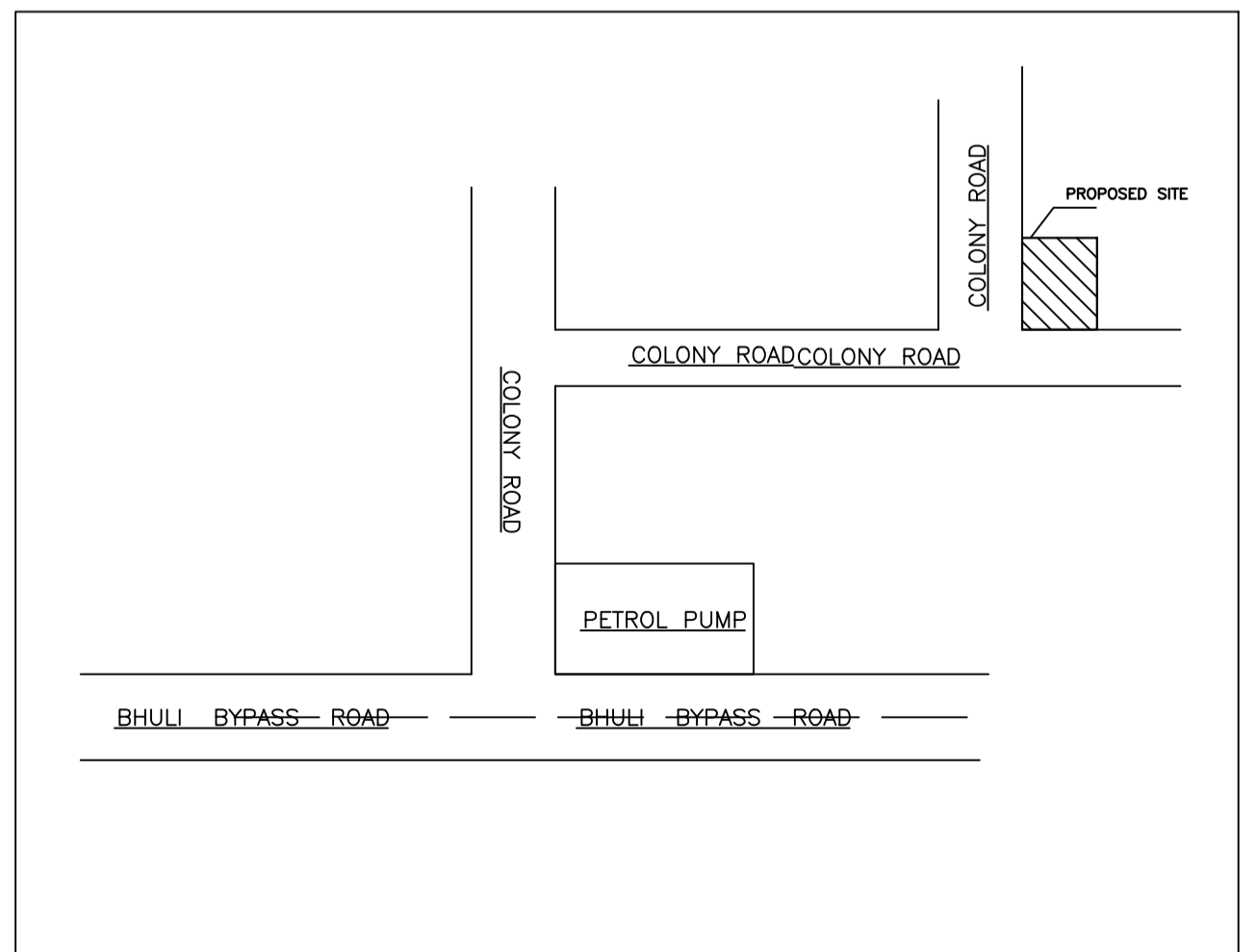

Proposal Basic Information

Proposal File No.	MADA/BP/0288/2022
Owner Name	MD.WAZID
Khata No	24(old) 30,32(new)
Plot No	139(OLD)215,2,16,219,225(new)
Village Name	Mohidih
Use	Residential
SubUse	Bungalow/ Dwelling / Non Apartment

AREA STATEMENT MINERAL AREA DEVELOPMENT AUTHORITY

Version No.:	1.0.66
Version Date:	16/10/2020
Region:	JHARKHAND URBAN LOCAL BODIES
District:	DHANBAD
Authority:	MINERAL AREA DEVELOPMENT AUTHORITY
Inward No.:	MADA/BP/0288/2022
Application Type:	General Proposal
Project Type:	Building Permission
Nature of Development:	New
Location of Development Area:	Old Area
Plot Use:	Residential
Plot SubUse:	Bungalow/ Dwelling / Non Apartment
Plot Nearby/Religious/Structure:	NA
Plot SubPlot No.:	139(OLD)215,2,16,219,225(new)
North:	Road Width - 6.10 WIDE ROAD
South:	Plot No. - JESSIMUDDIN ANSARI
East:	Plot No. - AYSHA KHATUN
West:	Road Width - 6.10 WIDE ROAD

AREA DETAILS:

AREA OF PLOT (Minimum)	(A)	SQ.MT.
NET AREA OF PLOT(Gross Plot Area - Deduction from Gross Plot area)	(A-Deductions)	159.08
Deduction for Balance Plot Area(from Gross Plot Area)		
Common Plot		24.65
Total		24.65
BALANCE AREA OF PLOT(Net Plot Area - Recreational/Amenity space)	(A-Deductions)	134.43
PLOT AREA FOR COVERAGE(Net Plot Area)	(A-Deductions)	159.08
Plot Area for FAR (Net Plot Area + Road Widening Area)	(A-Deductions)	159.08

COVERAGE CHECK

Permissible Coverage area (70.00 %)	111.36
Proposed Coverage Area (54.38 %)	86.50
Total Prop. Coverage Area (54.38 %)	86.50
Balance coverage area (15.63 %)	24.66

FAR CHECK

Perm. FAR Area (2.500)	397.70
Total Perm. FAR area	397.70
Residential FAR	161.17
Proposed FAR Area	161.17
Total Proposed FAR Area	161.17
Consumed FAR (Factor)	1.01
Balance FAR Area	236.53

BUILT UP AREA CHECK

Total Proposed BuiltUp Area	161.17
-----------------------------	--------

ARCHITECT (Regd) Lalan Prasad Singh
ENGINEER (Regd)
SUPERVISOR (Regd)
OWNER (Regd) MD.WAZID

DEVELOPMENT AUTHORITY LOCAL BODY

COLOR INDEX

PLOT BOUNDARY	Black
ABUTTING ROAD	Green
PROPOSED CONSTRUCTION	Red
COMMON PLOT	Yellow
ROAD WIDENING AREA	Blue
EXISTING (To be retained)	Blue
EXISTING (To be demolished)	Yellow

Buildingwise Floor FAR Details

Floor Name	Building Name		Total	
	Proposed Built Up Area (Sq.mt.)	Proposed FAR Area (Sq.mt.)	Total Proposed Built Up Area (Sq.mt.)	Total FAR Area (Sq.mt.)
Ground Floor	86.50	86.50	86.50	86.50
First Floor	74.67	74.67	74.67	74.67
Terrace Floor	0.00	0.00	0.00	0.00
Total :	161.17	161.17	161.17	161.17

Building USE/SUBUSE Details

Building Name	Building Use	Building SubUse	Building Structure
AA (AA)	Residential	Bungalow/ Dwelling / Non Apartment	Non-Highrise

FAR & tenement Details (Table 4c-1)

Building	No. of Same Bldg	Total Built Up Area (Sq.mt.)	Proposed FAR Area (Sq.mt.) Resi.	Total FAR Area (Sq.mt.)	Total Consumed Additional FAR Area (Sq.mt.)	Tnmt (No.)
AA (AA)	1	161.17	161.17	161.17	161.17	01
Grand Total :	1	161.17	161.17	161.17	161.17	01

UnitBUA Table for Building :AA (AA)

FLOOR	Name	UnitBUA Type	UnitBUA Area	Carpet Area	No. of Rooms	No. of Tenement
GROUND FLOOR PLAN	SPLIT AA	FLAT	161.17	160.84	7	1
FIRST FLOOR PLAN	SPLIT AA	FLAT	0.00	0.00	7	0
Total:	-	-	161.17	160.84	14	1

LTP NAME AND SIGNATURE	STRUCTURAL ENG'S NAME AND SIGNATURE	BUILDER NAME AND SIGNATURE	DIGITAL SIGNATURE
Lalan Prasad Singh MADA/ENG/0001/2020			

Proposal Basic Information	
Proposal File No.	MADA/BP/0288/2022
Owner Name	MD.WAZID
Khata No	24(old) 30,32(new)
Plot No	139(oid)215,2,16,219,225(new)
Village Name	Mohidih
Use	Residential
SubUse	Bungalow/ Dwelling / Non Apartment

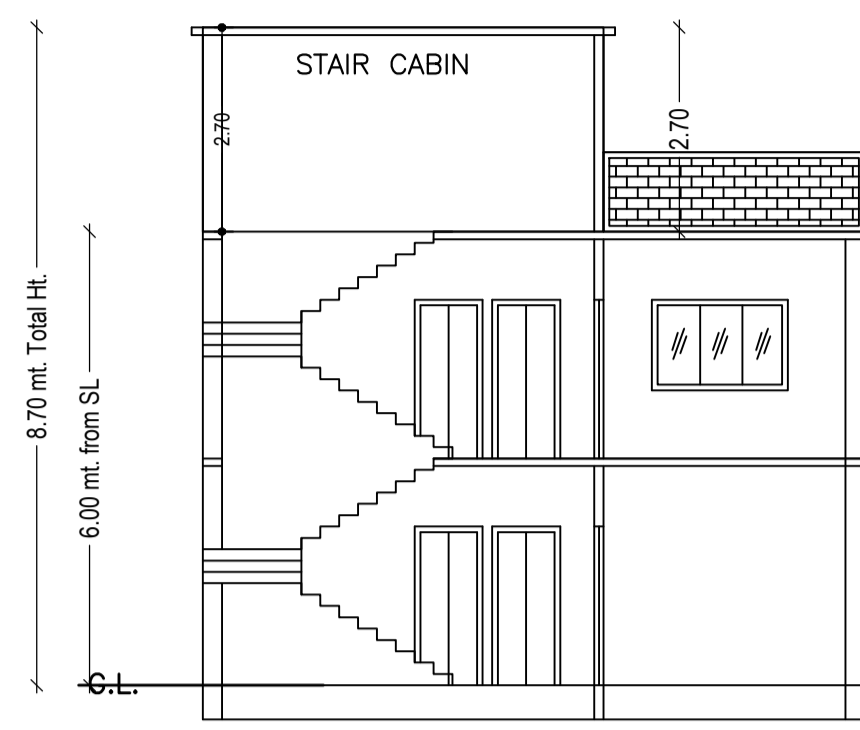
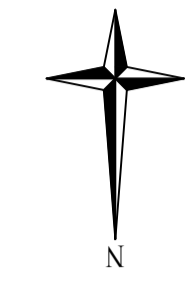

SECTION ON X-X

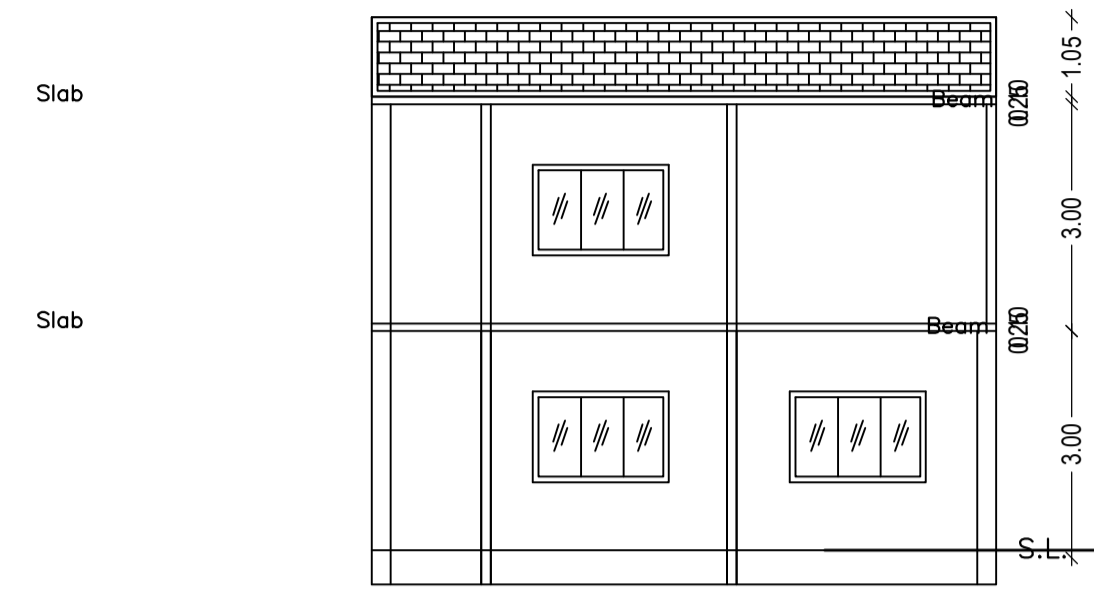

SECTION ON Y-Y

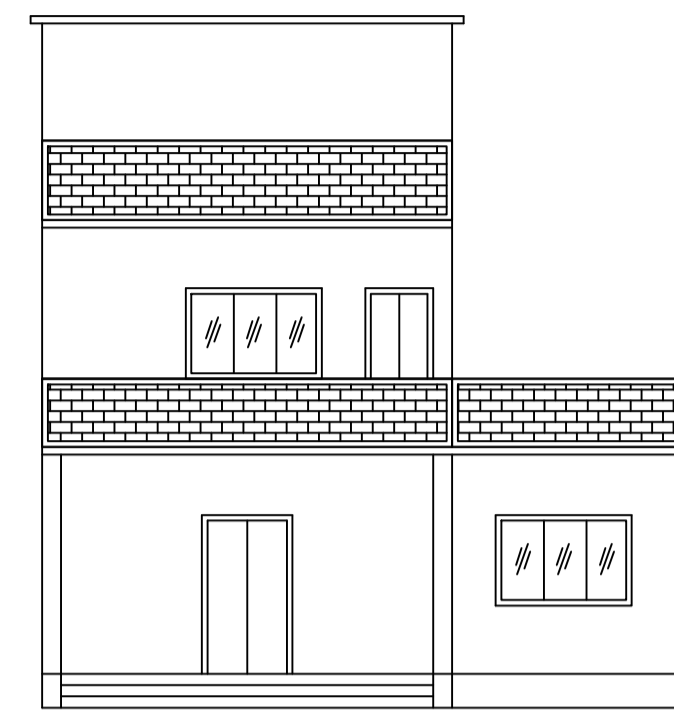

FRONT ELEVATION

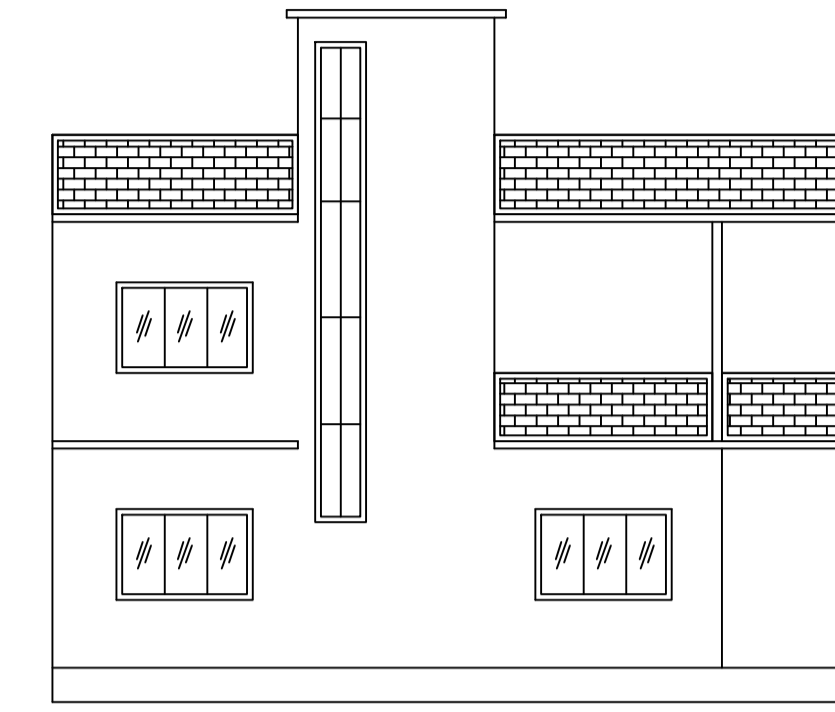

LEFT SIDE ELEVATION

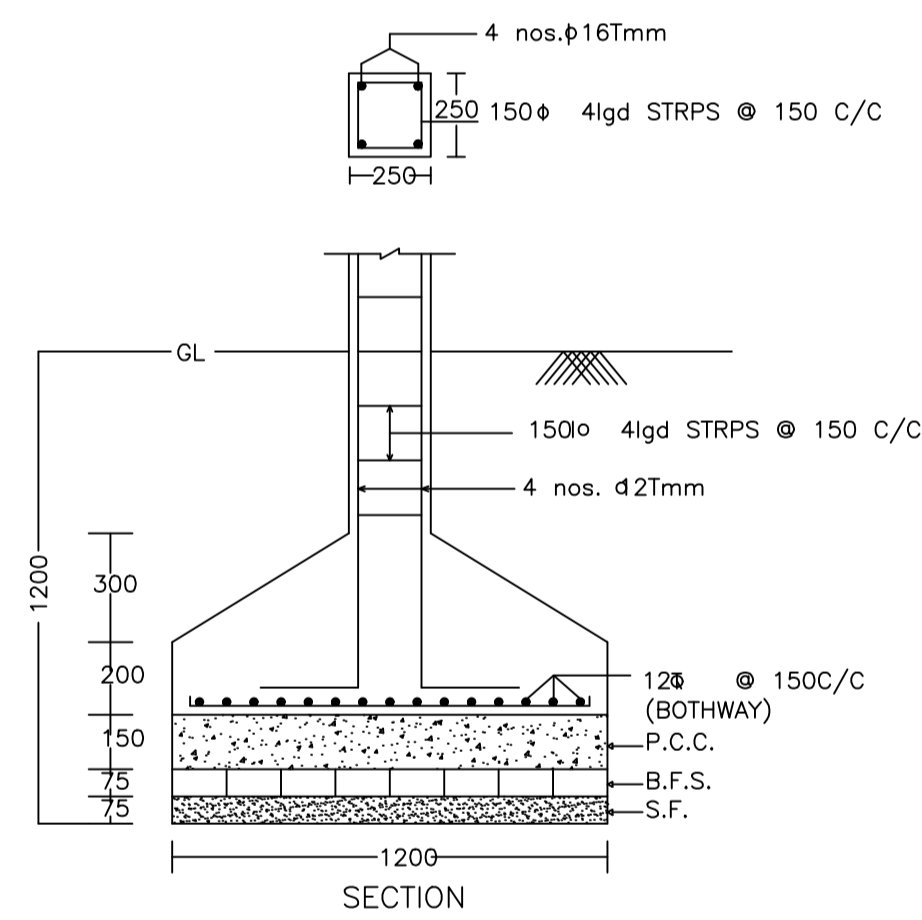

DETAIL OF COLUMNS

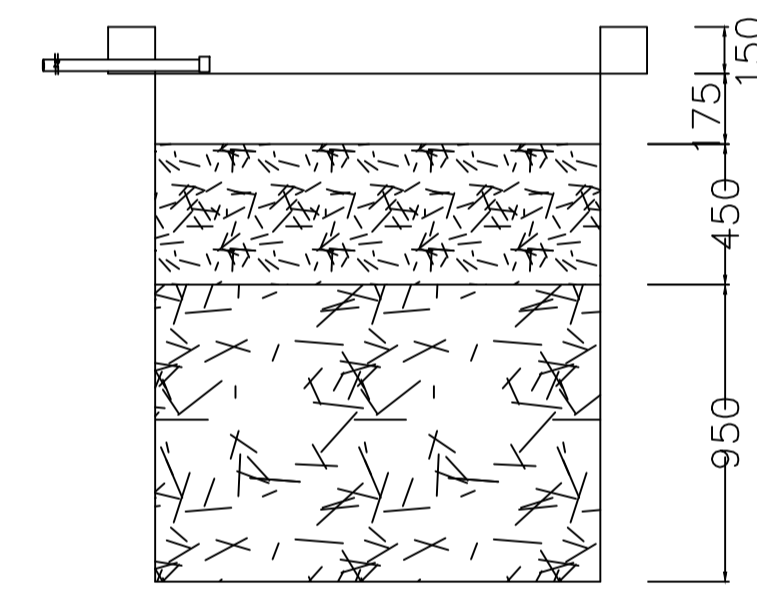

SECTION AT Y-Y

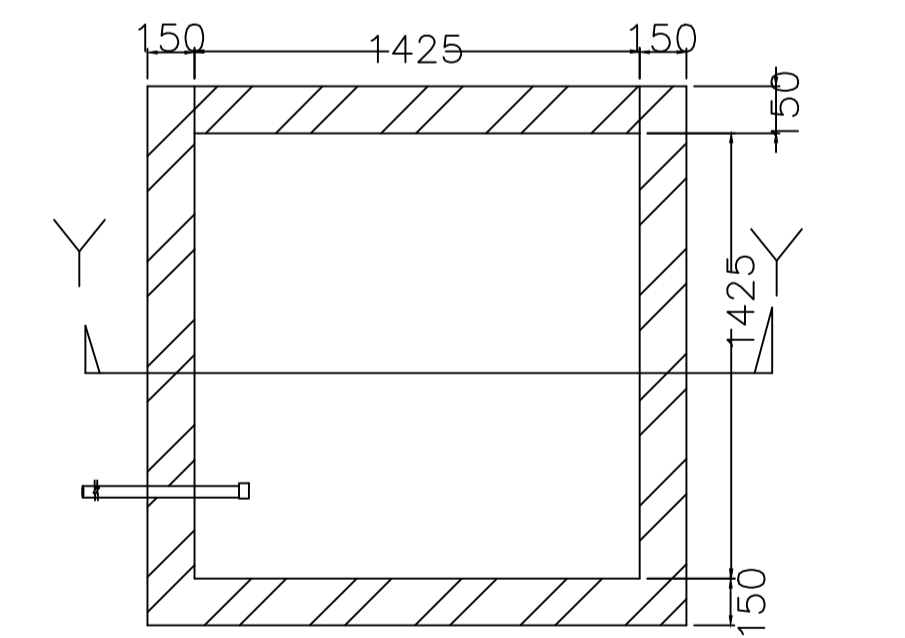

PLAN OF RECHARGE WELL WATER HARVESTING

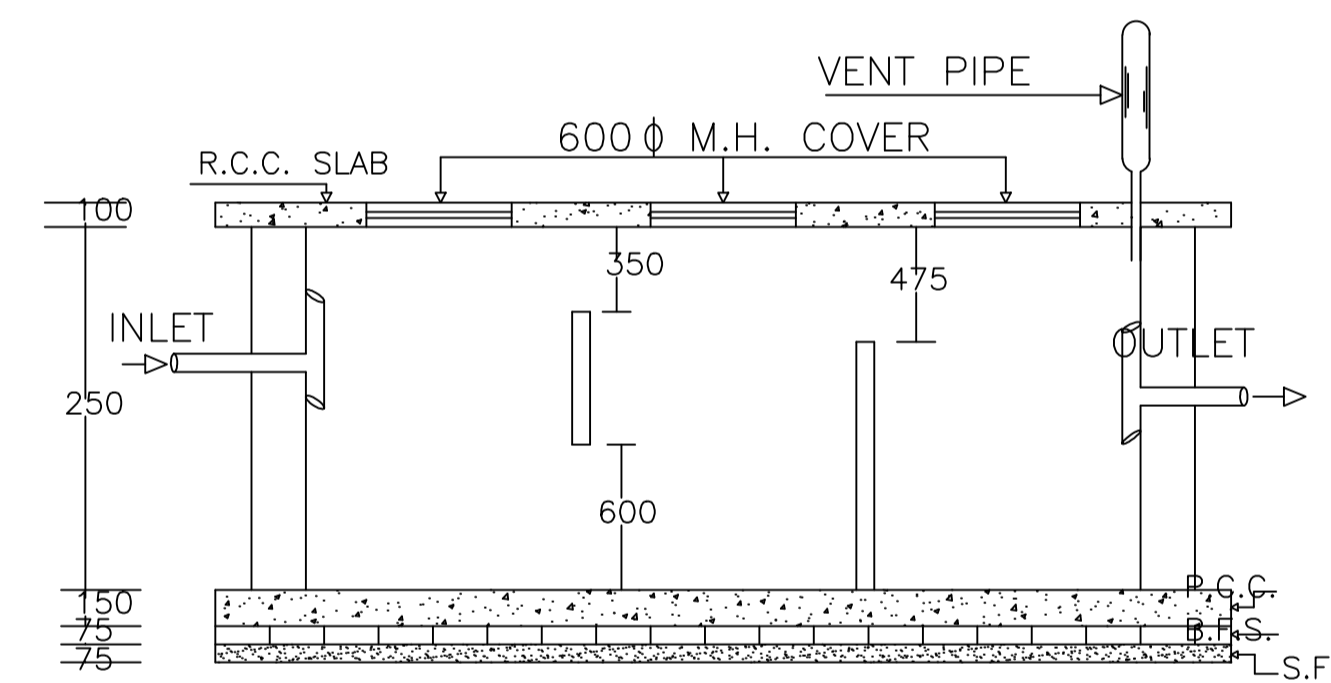

PLAN OF SEPTIC TANK

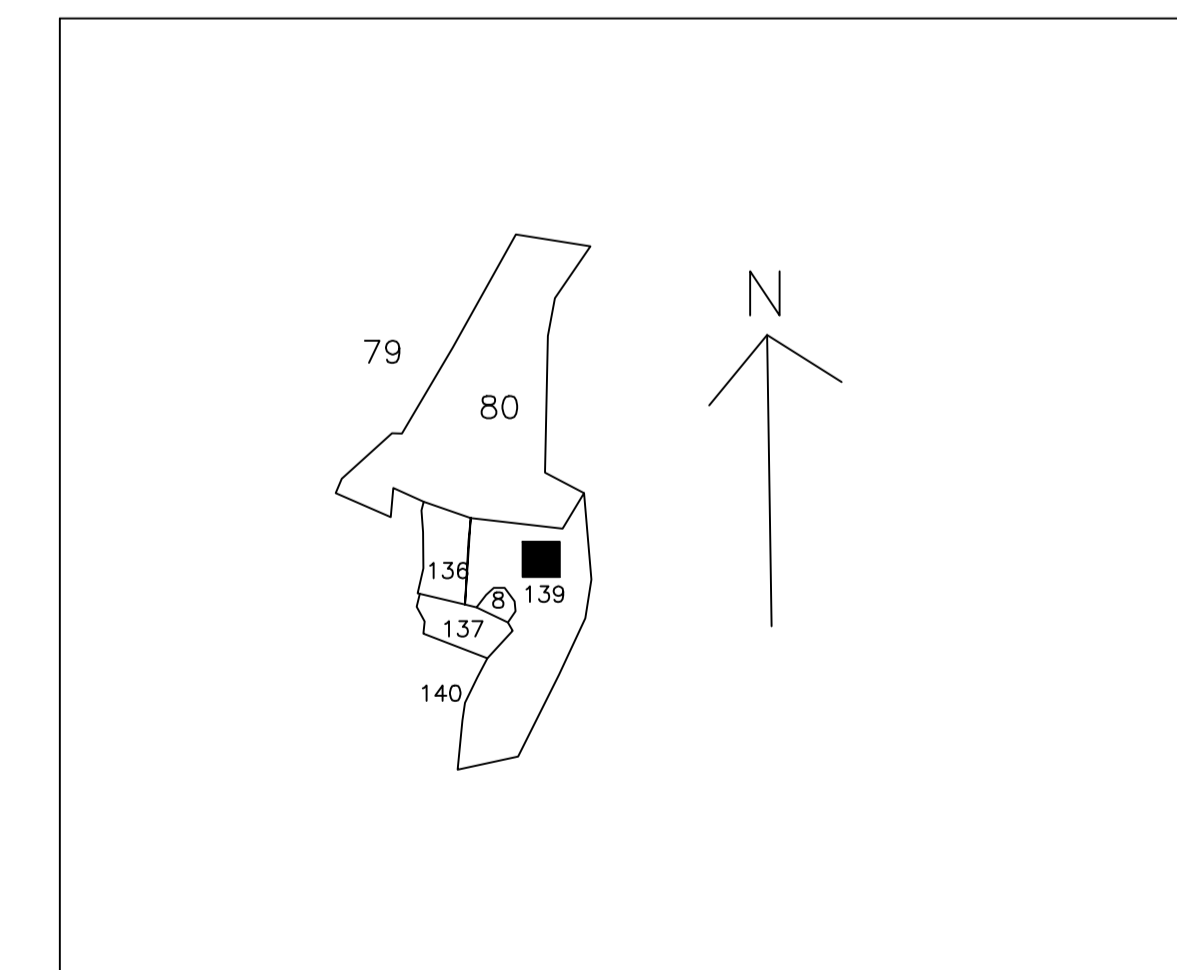
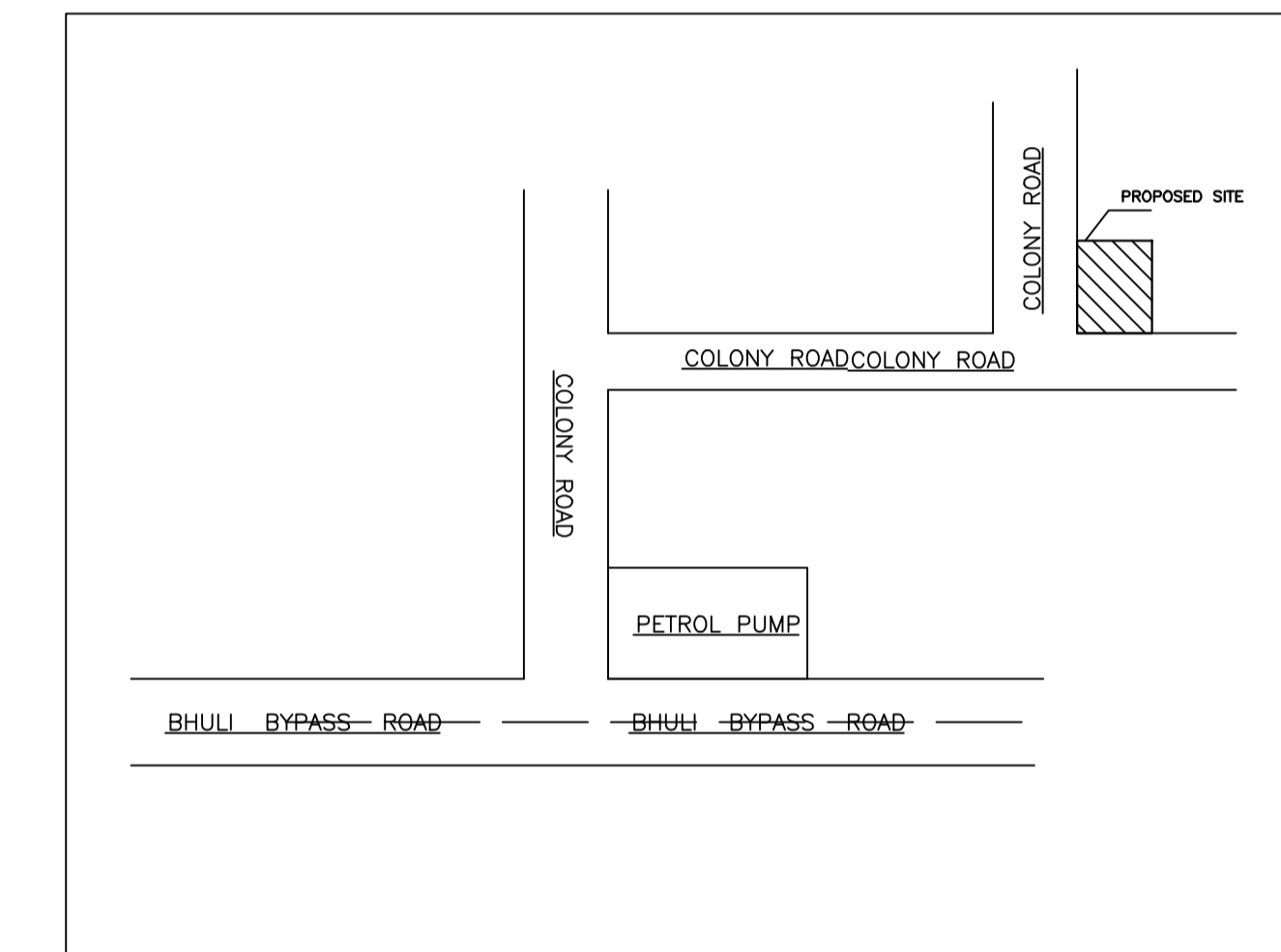

LTP NAME AND SIGNATURE	STRUCTURAL ENG'S NAME AND SIGNATURE	BUILDER NAME AND SIGNATURE	DIGITAL SIGNATURE
Lalan Prasad Singh MADA/ENG/0001/2020			