

Proposal Basic Information

Proposal File No.	MADA/BP/0410/2022
Owner Name	KUSUM DEVI
Khata No	OLD-69, NEW-35
Plot No	OLD-223, NEW-258
Village Name	Damodarapur
Use	Residential
SubUse	Bungalow/ Dwelling / Non Apartment

AREA STATEMENT MINERAL AUTHORITY  
VERSION NO: 1.0.65  
VERSION DATE: 16/10/2020

Region: JHARKHAND URBAN	Plot Use: Residential
LOCAL BODIES	Plot SubUse: Bungalow/ Dwelling / Non Apartment
District: DHANBAD	PlotNearby/ReligiousStructure: NA
Authority: MINERAL AREA DEVELOPMENT AUTHORITY	Plot/SubPlot No: OLD-223, NEW-258
Inward No: MADA/BP/0410/2022	North: Road Width - 3.96 MTR WIDE ROAD
Application Type: General Proposal	South: Plot No. - PART OF SAME PLOT
Project Type: Building Permission	East: Plot No. - PART OF SAME PLOT
Nature of Development: New	West: Plot No. - PLOT NO.- 212
Location of Development Area: Old Area	

AREA DETAILS:		SQ.MT.
NET AREA OF PLOT (Minimum)	(A)	178.79
Deduction from Gross Plot Area	(A-Deductions)	178.79
Deduction for Balance Plot Area (from Gross Plot Area)		
Common Plot		14.85
Total		14.85
BALANCE AREA OF PLOT (Net Plot Area - Recreational/Amenity space)	(A-Deductions)	163.94
PLOT AREA FOR COVERAGE (Net Plot Area)	(A-Deductions)	178.79
Plot Area for FAR (Net Plot Area + Road Widening Area)	(A-Deductions)	178.79
COVERAGE CHECK		
Permissible Coverage area ( 70.00 % )		125.15
Proposed Coverage Area ( 56.05 % )		100.21
Total Prop. Coverage Area ( 56.05 % )		100.21
Balance coverage area ( 13.95 % )		24.94
FAR CHECK		
Perm. FAR Area ( 1.500 )		268.18
Total Perm. FAR area		268.18
Residential FAR		200.43
Proposed FAR Area		200.43
Total Proposed FAR Area		200.43
Consumed FAR (Factor)		1.12
Balance FAR Area		67.75
BUILT UP AREA CHECK		
Total Proposed BuiltUp Area		200.42
ARCHITECT (Regd)	SANJEEV KUMAR RAY	
ENGINEER (Regd)		
SUPERVISOR (Regd)	KUSUM DEVI	
OWNER (Regd)		
DEVELOPMENT AUTHORITY	LOCAL BODY	

PLOT BOUNDARY	Black
ABUTTING ROAD	Green
PROPOSED CONSTRUCTION	Red
COMMON PLOT	Yellow
ROAD WIDENING AREA	Blue
EXISTING (To be retained)	Light Blue
EXISTING (To be demolished)	Dark Blue

Floor Name	Building Name A (A)		Total	
	Proposed Built Up Area (Sq.mt.)	Proposed FAR Area (Sq.mt.)	Total Proposed Built Up Area (Sq.mt.)	Total FAR Area (Sq.mt.)
Ground Floor	100.21	100.21	100.21	100.21
First Floor	100.21	100.21	100.21	100.21
Terrace Floor	0.00	0.00	0.00	0.00
Total :	200.42	200.42	200.42	200.42

Building Name	Building Use	Building SubUse	Building Structure
A (A)	Residential	Bungalow/ Dwelling / Non Apartment	Non-Highrise

Building	No. of Same Bldg	Total Built Up Area (Sq.mt.)	Proposed FAR Area (Sq.mt.)	Total FAR Area (Sq.mt.)	Additional FAR Area (Sq.mt.)	Tnmt (No.)
A (A)	1	200.42	200.42	200.42	200.42	01
Grand Total :	1	200.42	200.42	200.42	200.42	01

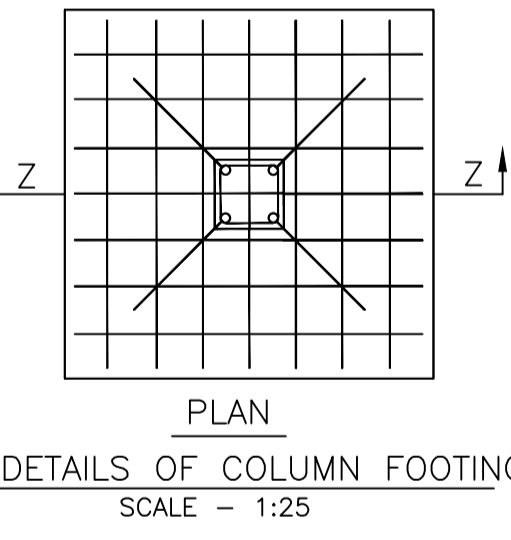
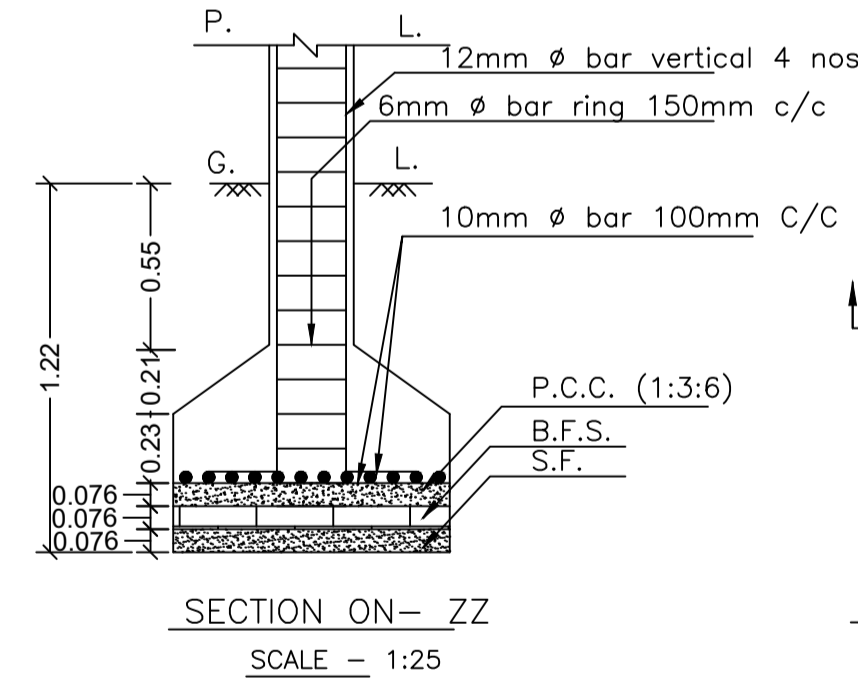
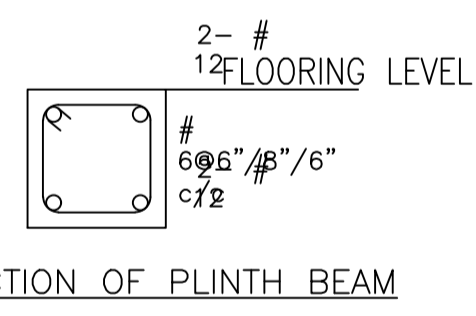
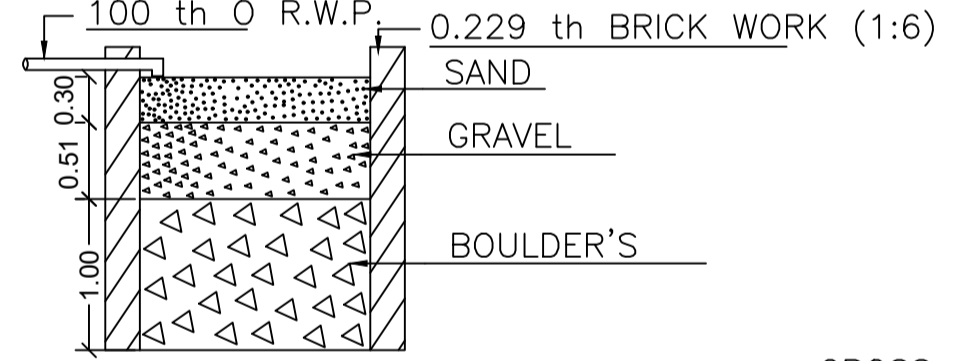
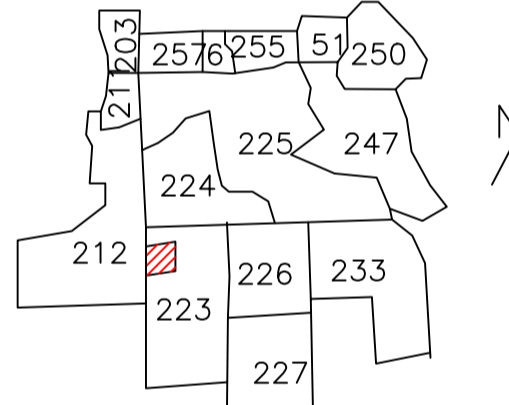
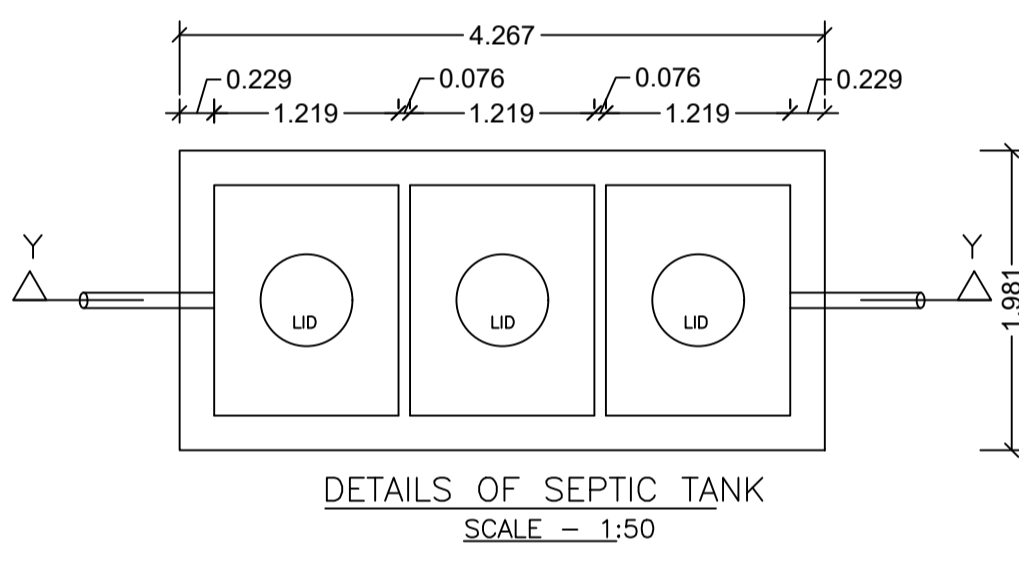
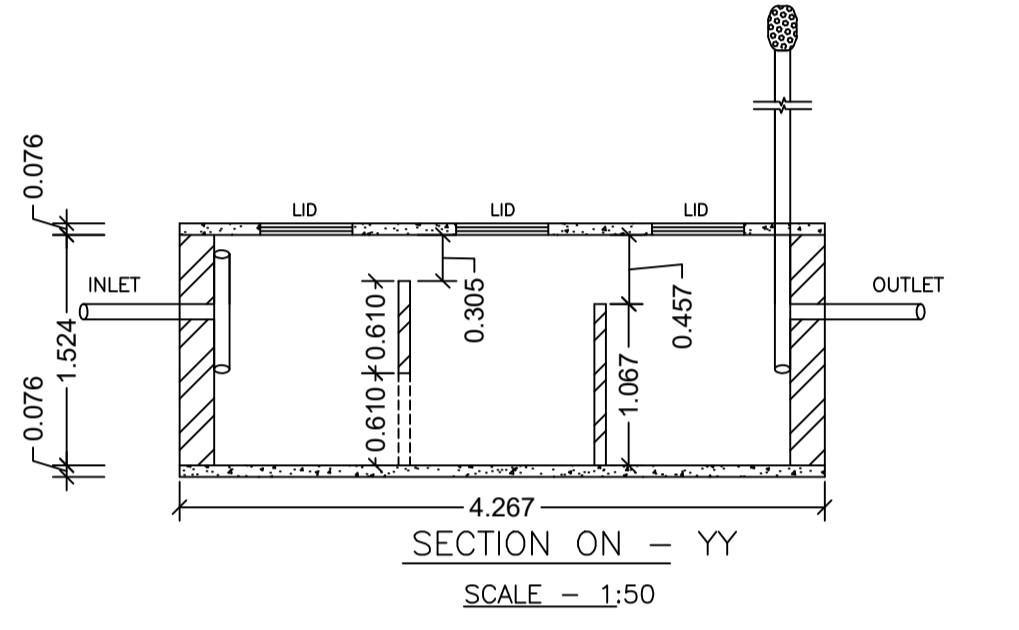
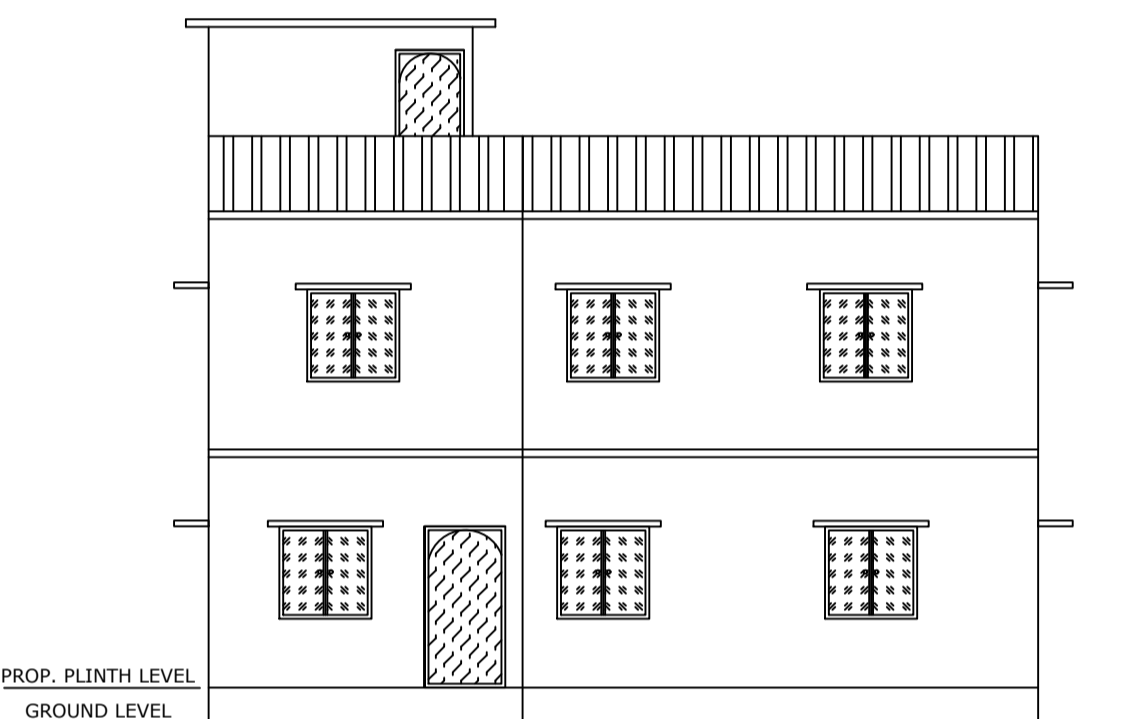
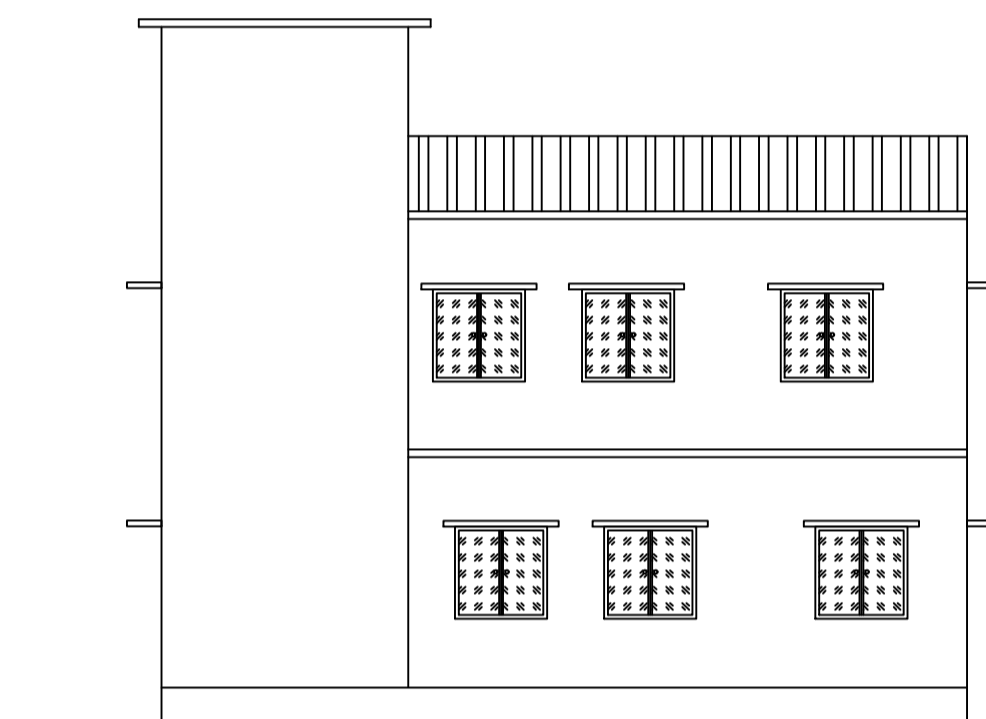
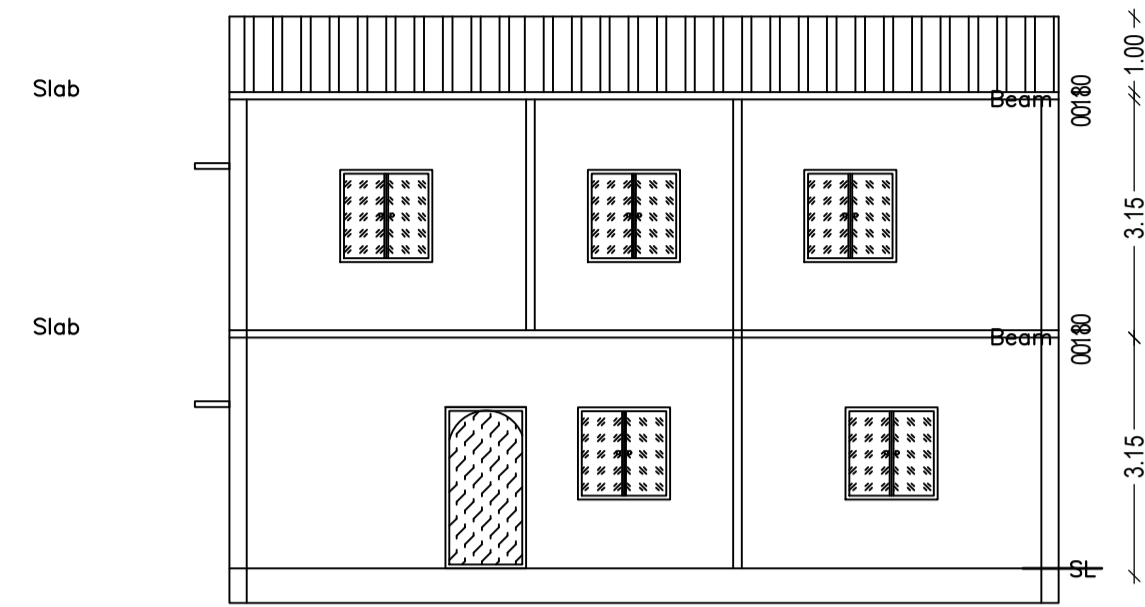
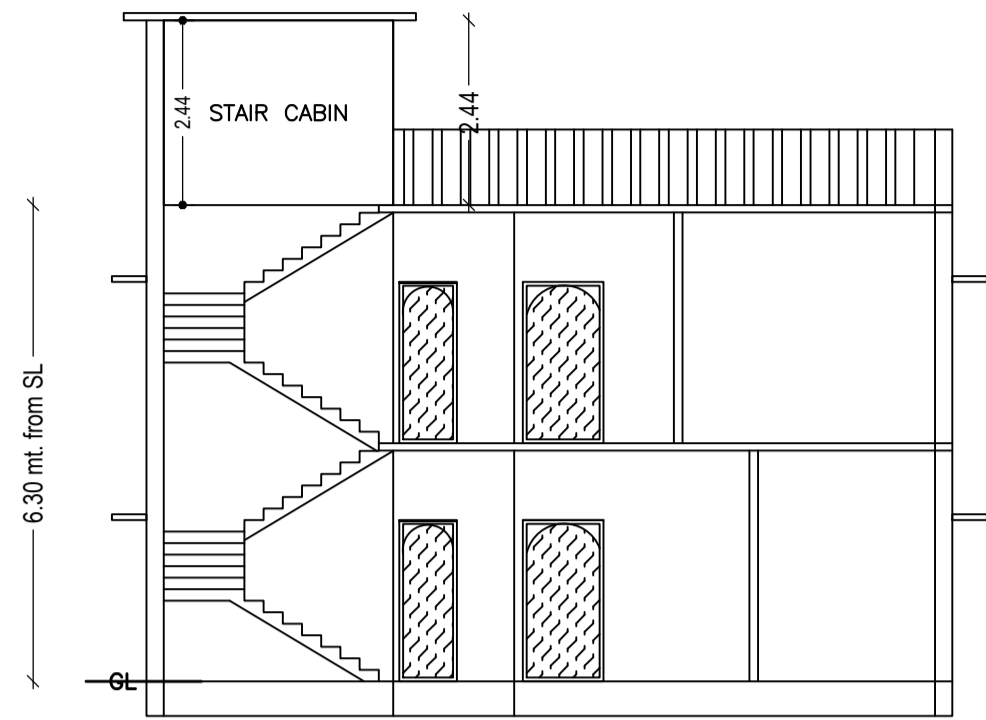
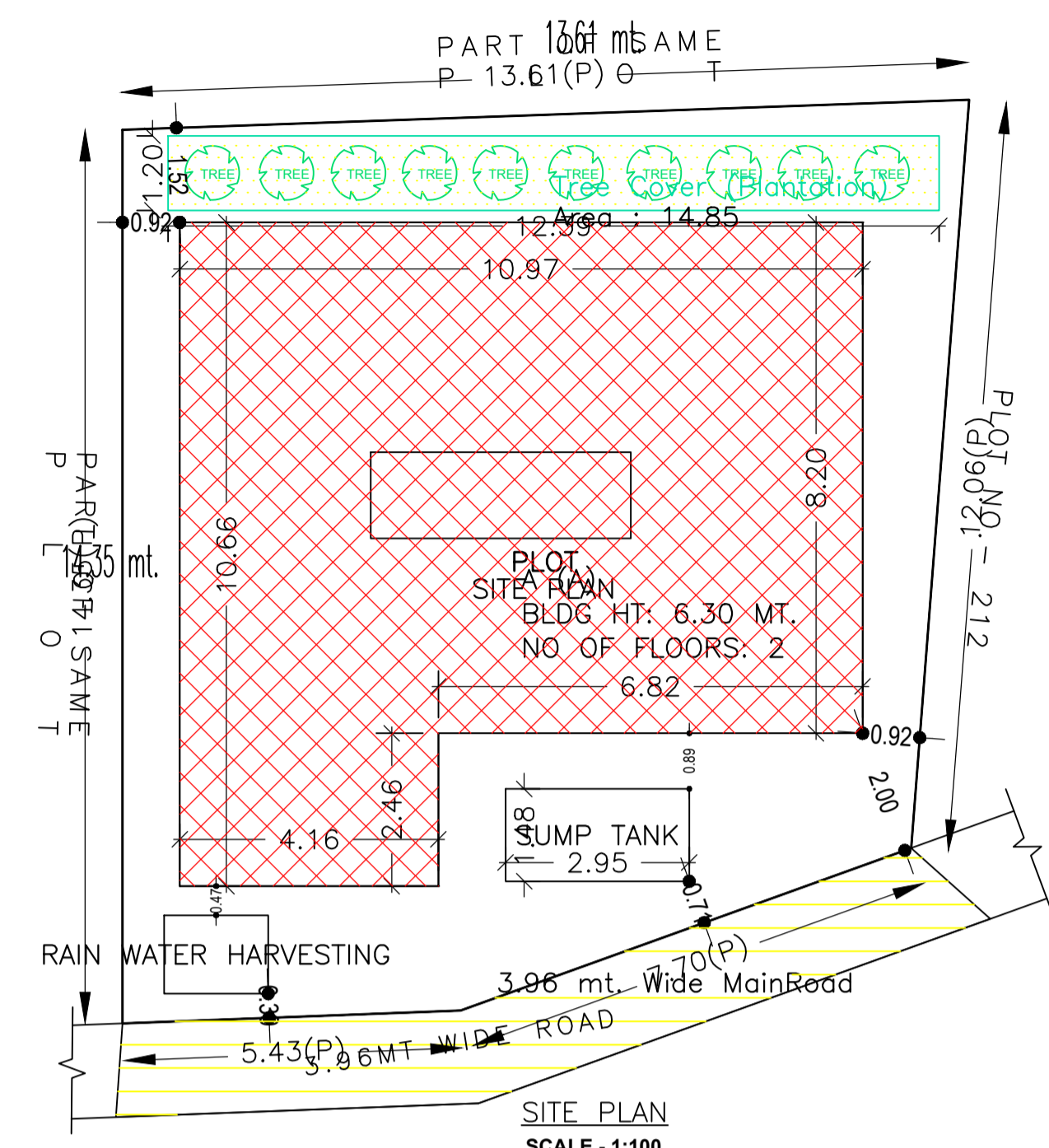

Floor Name	Total Built Up Area (Sq.mt.)	Proposed FAR Area (Sq.mt.)	Total FAR Area (Sq.mt.)	Total Consumed Additional FAR Area (Sq.mt.)	Tnmt (No.)
Ground Floor	100.21	100.21	100.21	100.21	01
First Floor	100.21	100.21	100.21	100.21	00
Terrace Floor	0.00	0.00	0.00	0.00	00
Total :	200.42	200.42	200.42	200.42	01
Total Number of Same Buildings :					
Total :	200.42	200.42	200.42	200.42	01

BUILDING NAME	NAME	LENGTH	HEIGHT	NOS
A (A)	D	0.76	2.10	02
A (A)	D	0.79	2.10	02
A (A)	D	0.91	2.10	02
A (A)	D	1.07	2.10	05

BUILDING NAME	NAME	LENGTH	HEIGHT	NOS
A (A)	V	0.61	1.20	02
A (A)	W	1.22	1.20	20

FLOOR	Name	UnitBUA Type	UnitBUA Area	Carpet Area	No. of Rooms	No. of Tenement
GROUND FLOOR PLAN	SPLIT A	FLAT	200.43	200.35	7	1
FIRST FLOOR PLAN	SPLIT A	FLAT	0.00	0.00	7	0
Total:			200.43	200.35	14	1

ISO\_A1\_(841.00\_x\_594.00\_MM)

LOCATION SCALE - NTS

LTP NAME AND SIGNATURE	STRUCTURAL ENG'S NAME AND SIGNATURE	BUILDER NAME AND SIGNATURE	DIGITAL SIGNATURE
SANJEEV KUMAR RAY MADA/ENG/0021/2019			

Proposal Basic Information	
Proposal File No.	MADA/BP/0410/2022
Owner Name	KUSUM DEVI
Khata No	OLD-69, NEW-35
Plot No	OLD-223, NEW-258
Village Name	Damodarpur
Use	Residential
SubUse	Bungalow/ Dwelling / Non Apartment

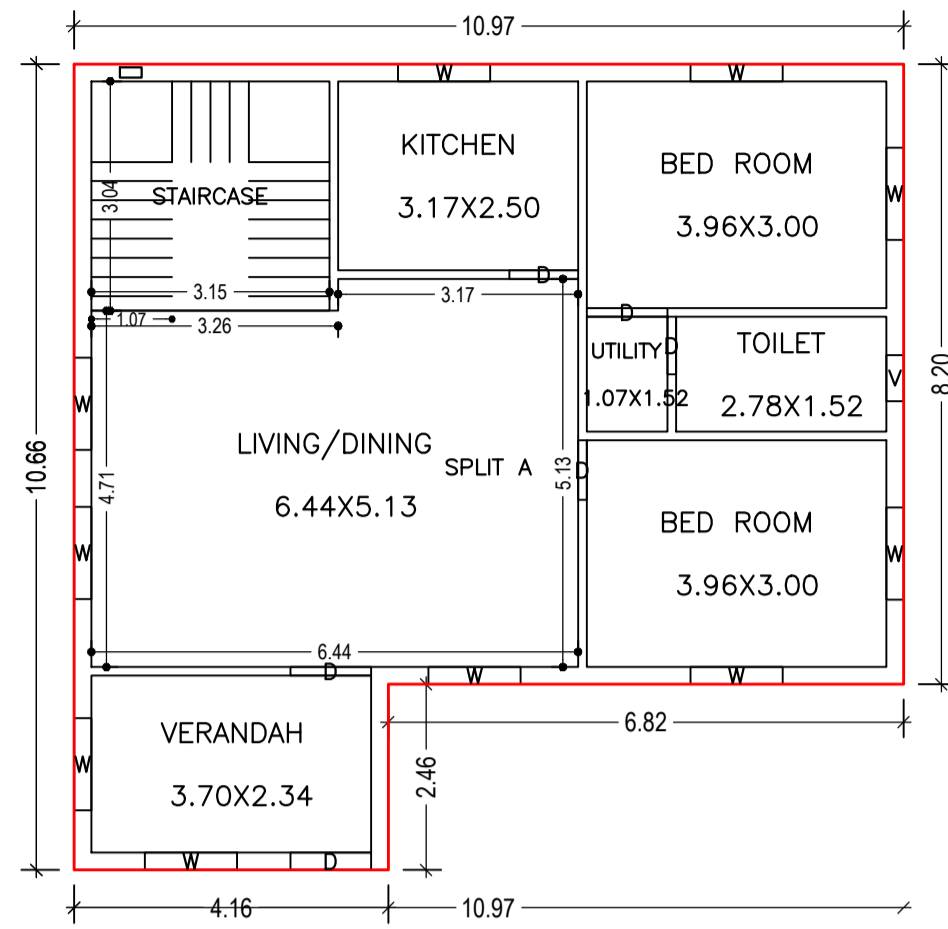
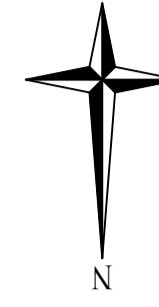

GROUND FLOOR PLAN  
(Proposed)  
(SCALE 1:100)

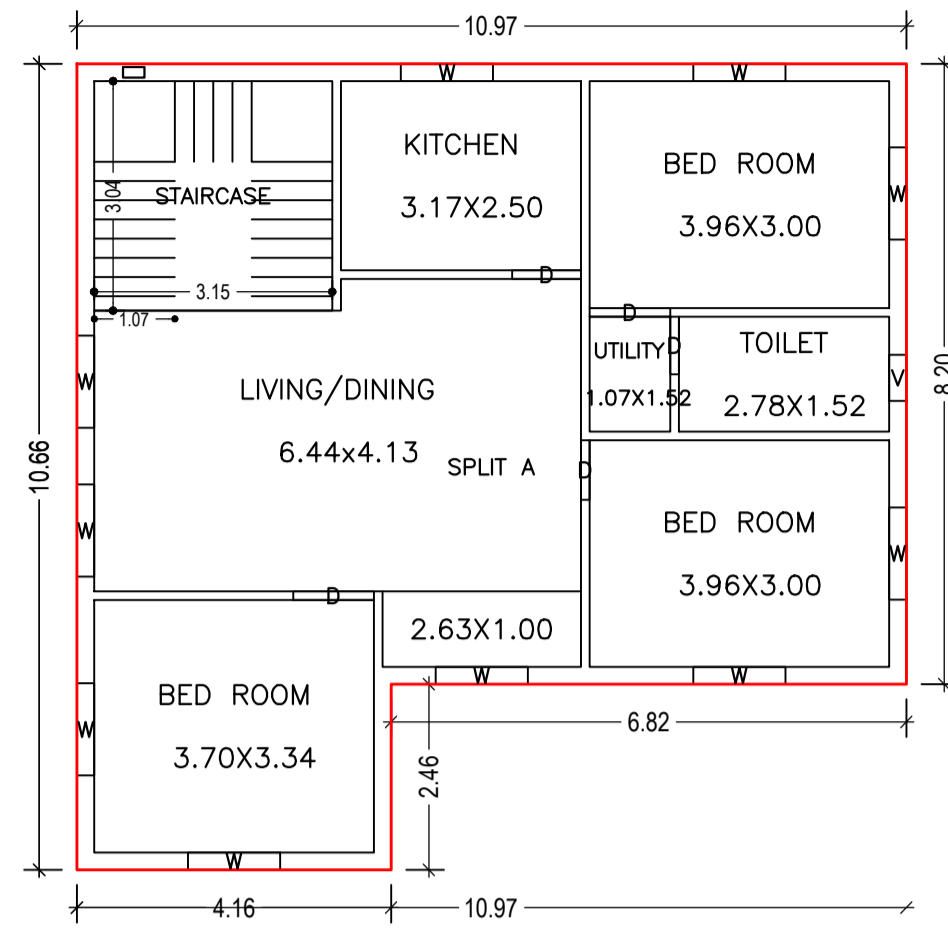

FIRST FLOOR PLAN  
(Proposed)  
(SCALE 1:100)

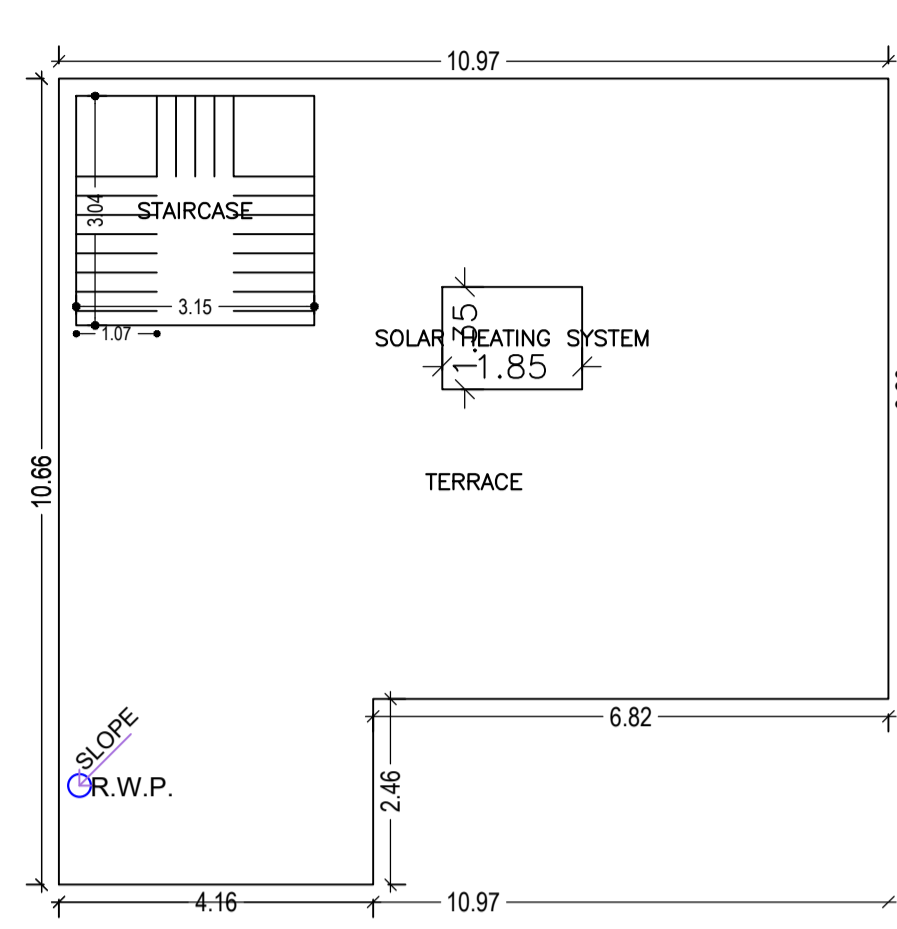

TERRACE FLOOR PLAN  
(SCALE 1:100)

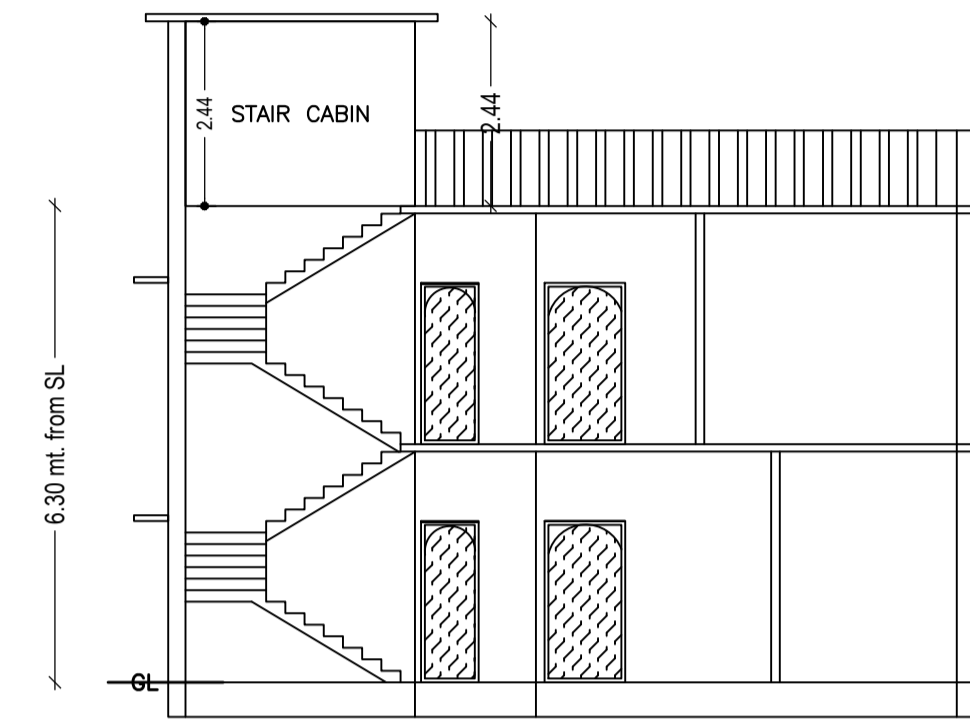

SECTION ON: 'A-A'  
SCALE - 1:100

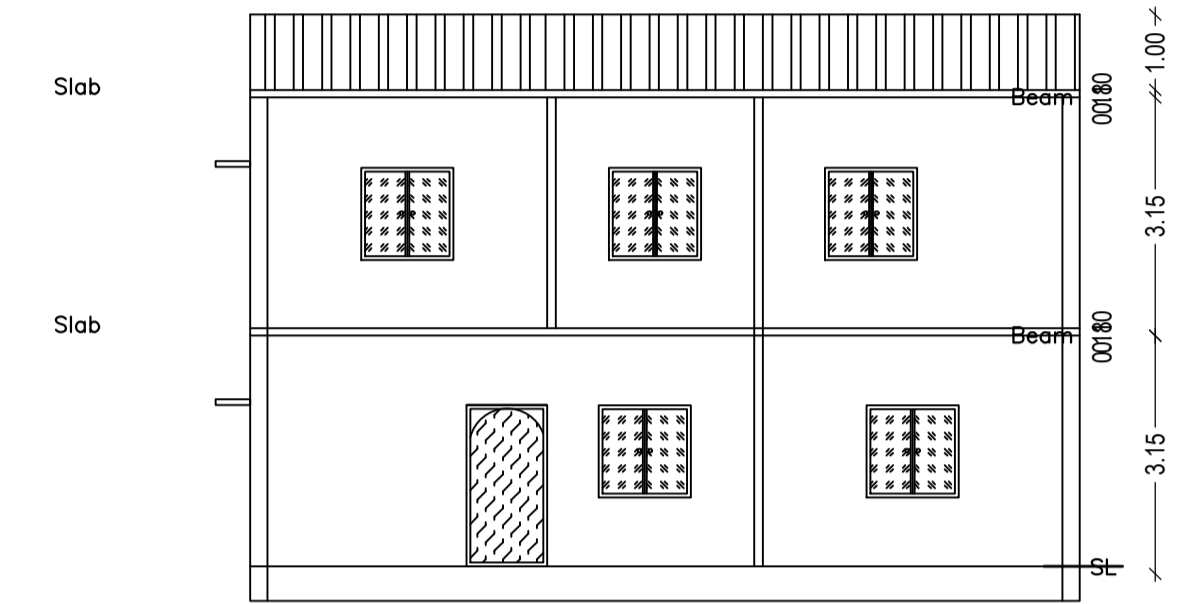

SECTION ON: 'B-B'  
SCALE - 1:100

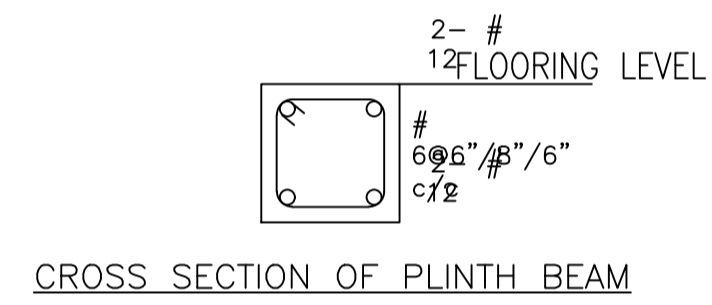

CROSS SECTION OF PLINTH BEAM

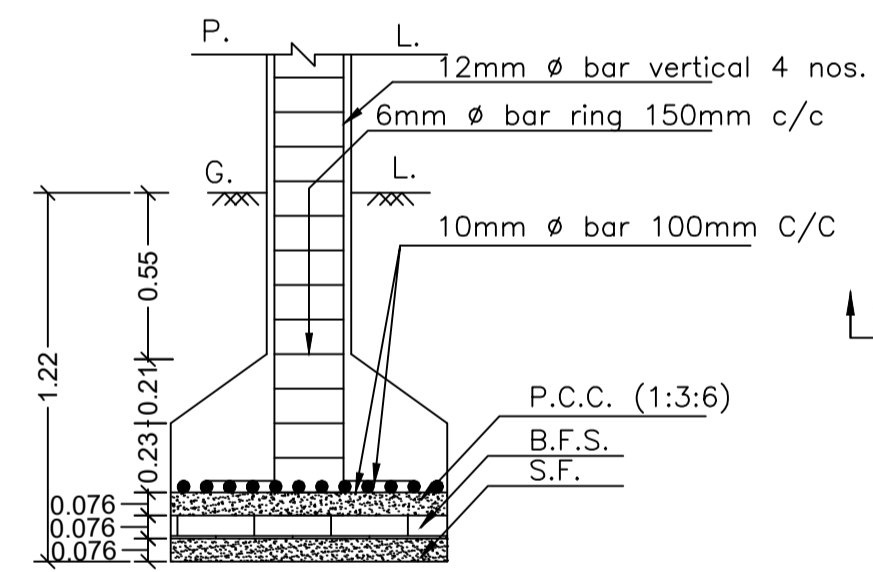

SECTION ON- ZZ  
SCALE - 1:25

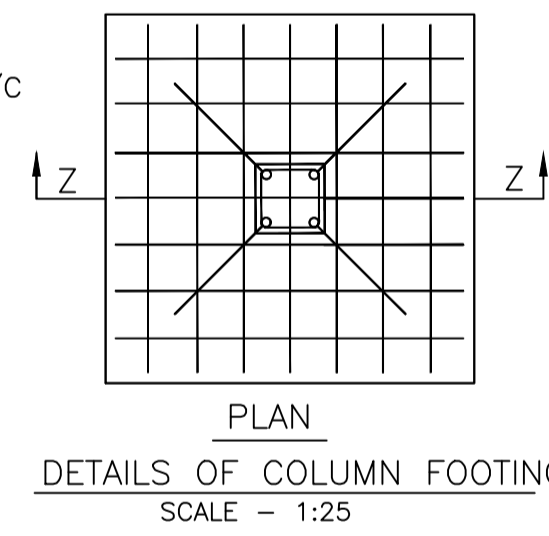

PLAN  
DETAILS OF COLUMN FOOTING  
SCALE - 1:25

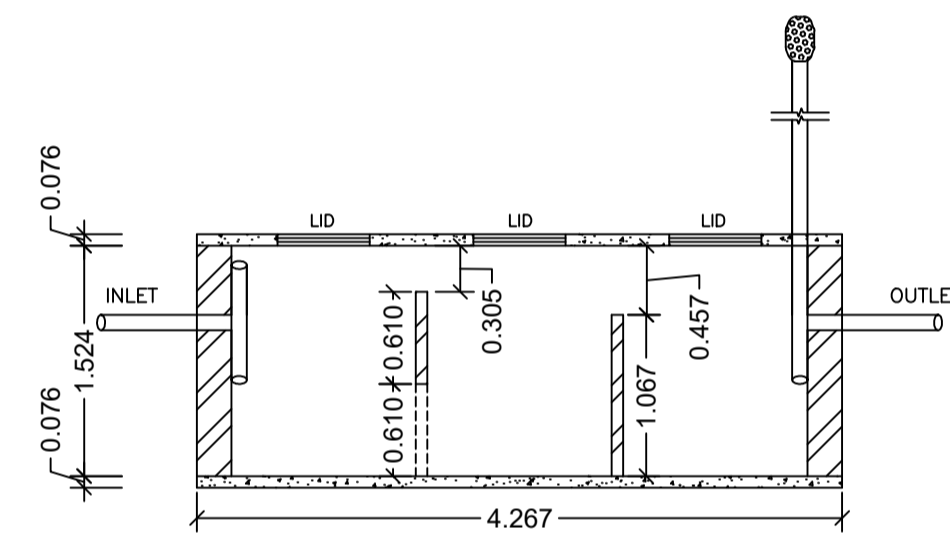

SECTION ON - YY  
SCALE - 1:50

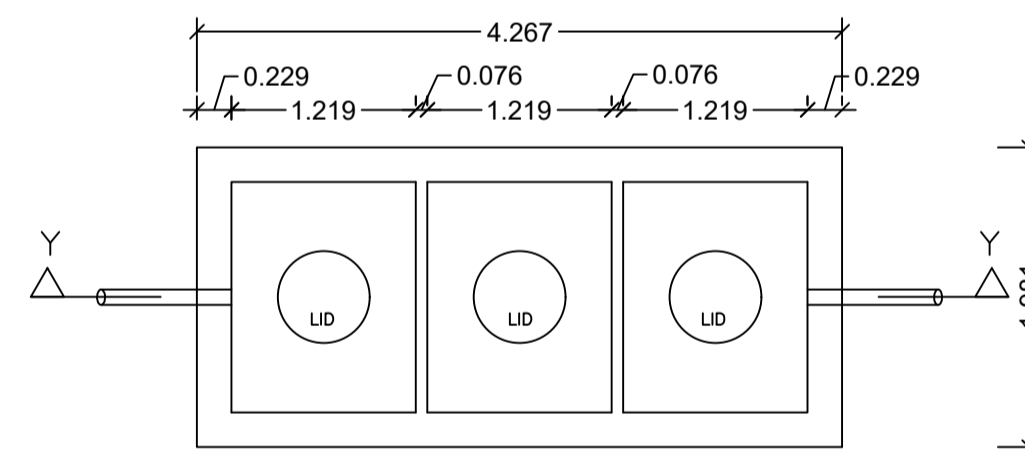

DETAILS OF SEPTIC TANK  
SCALE - 1:50

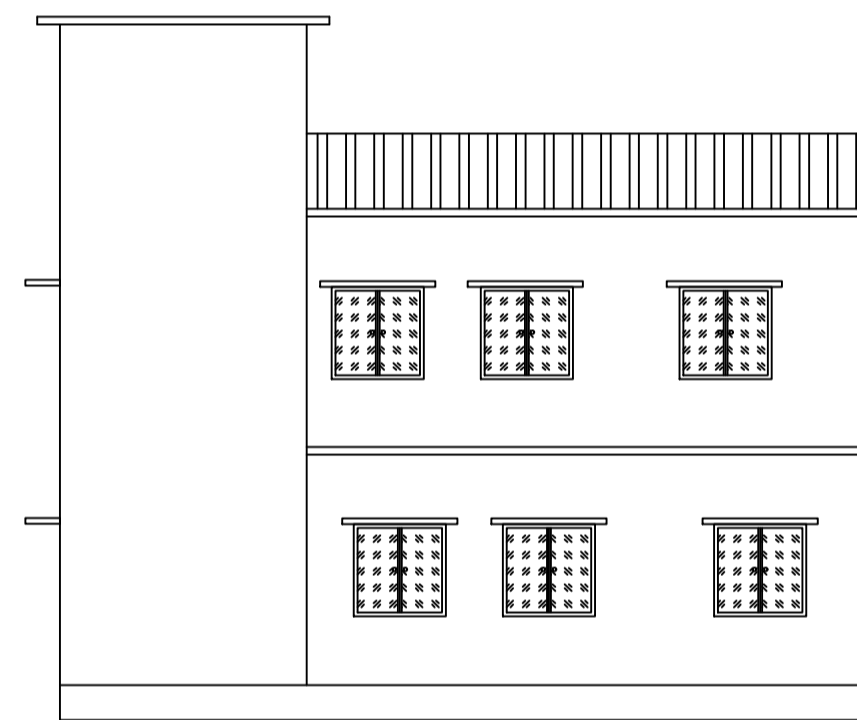

LEFT SIDE ELEVATION  
SCALE - 1:100

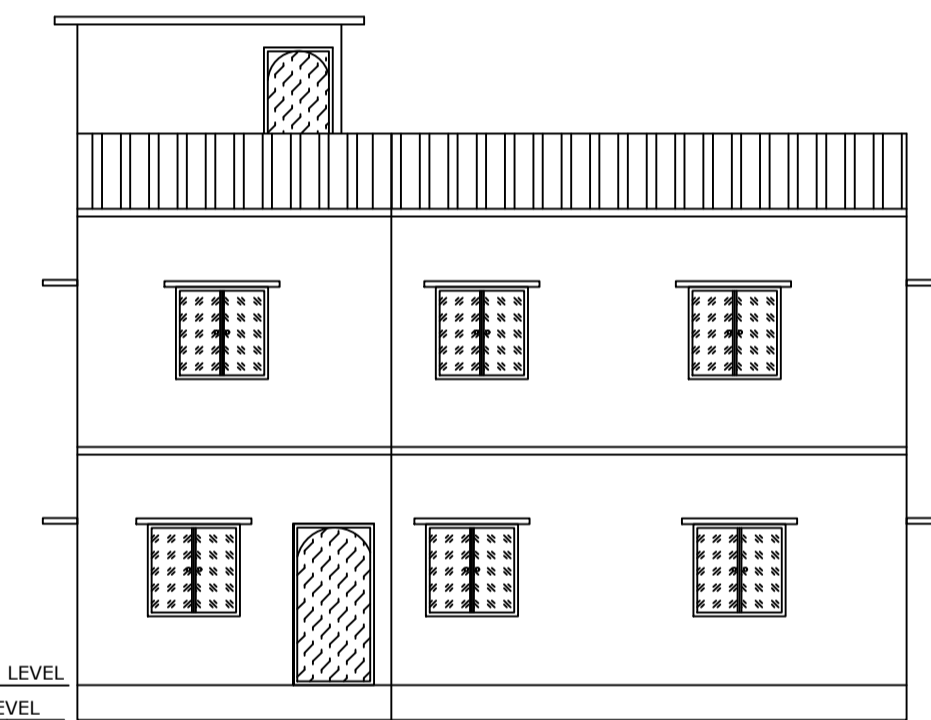

FRONT ELEVATION  
SCALE - 1:100

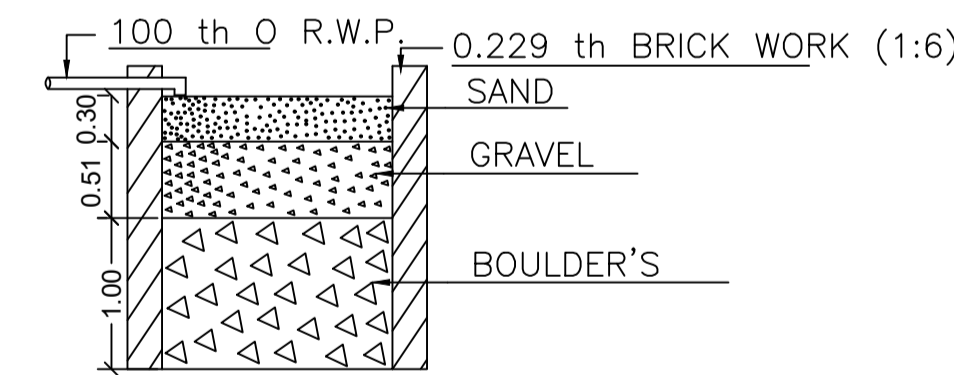

SECTION ON - 'X X'  
SCALE - 1:50

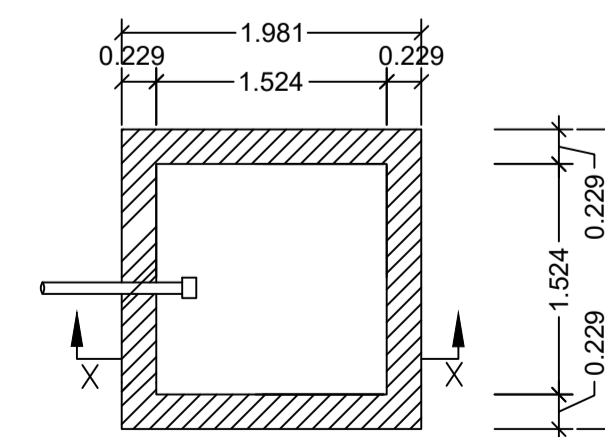

PLAN  
DETAILS OF WATER HARVESTING  
SCALE - 1:50

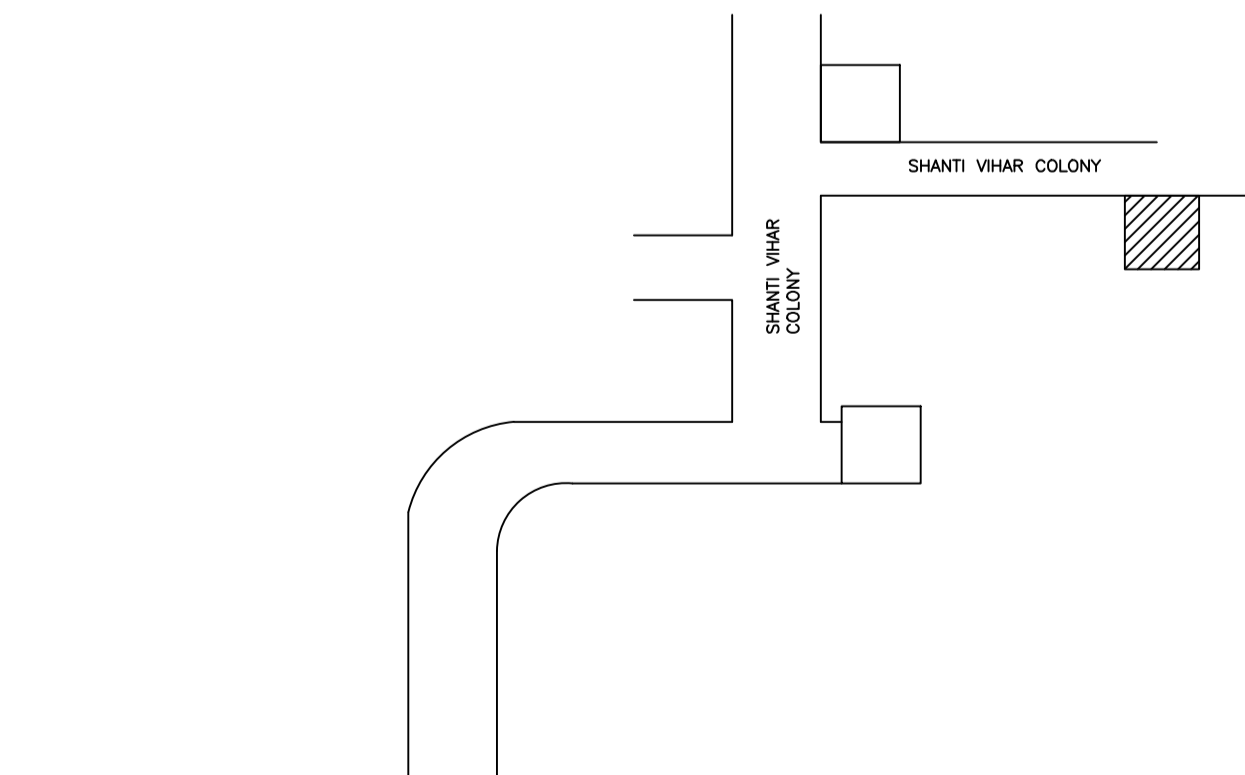

LOCATION  
SCALE - NTS

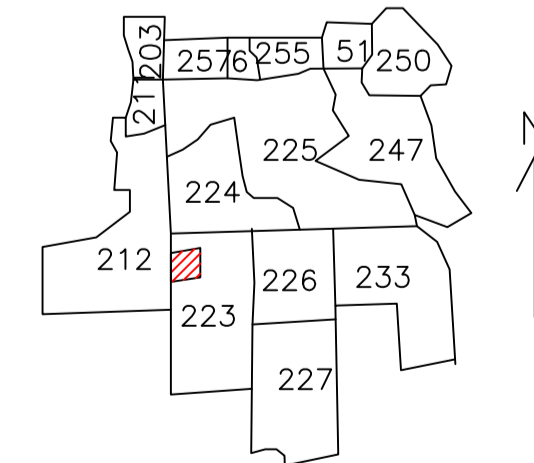

KEY PLAN  
SCALE - NTS

LTP NAME AND SIGNATURE	STRUCTURAL ENG'S NAME AND SIGNATURE	BUILDER NAME AND SIGNATURE	DIGITAL SIGNATURE
SANJEEV KUMAR RAY MADA/ENG/0021/2019			