

Proposal Basic Information

Proposal File No.	MADA/P/0012/2022
Owner Name	sri mukesh kumar
Khata No	52(old) 130(new)
Plot No	951(old) 1818, 1819(new)
Village Name	Damodarpur
Use	Residential
SubUse	Bungalow/ Dwelling / Non Apartment

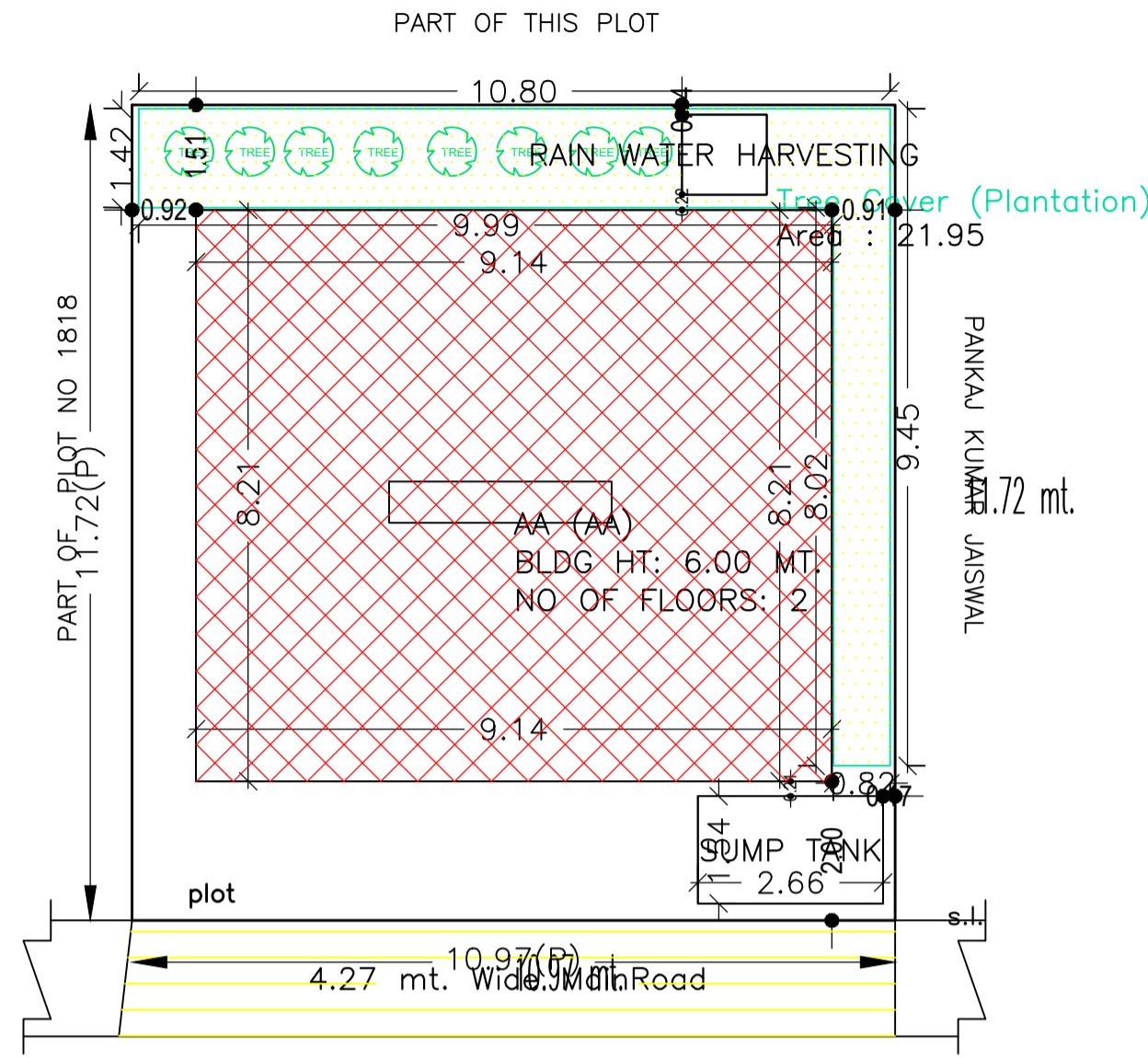

SITE PLAN

site plan

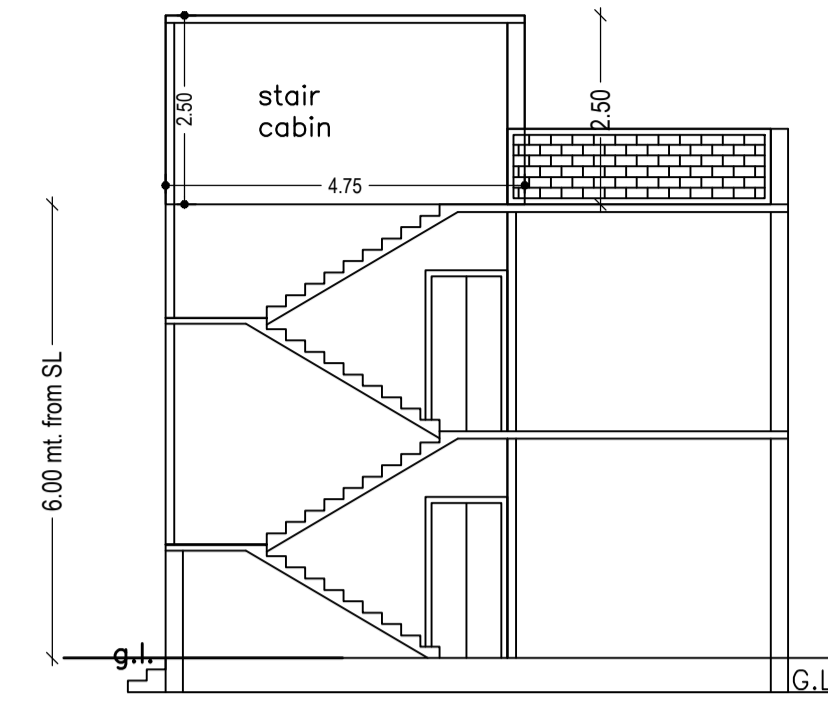
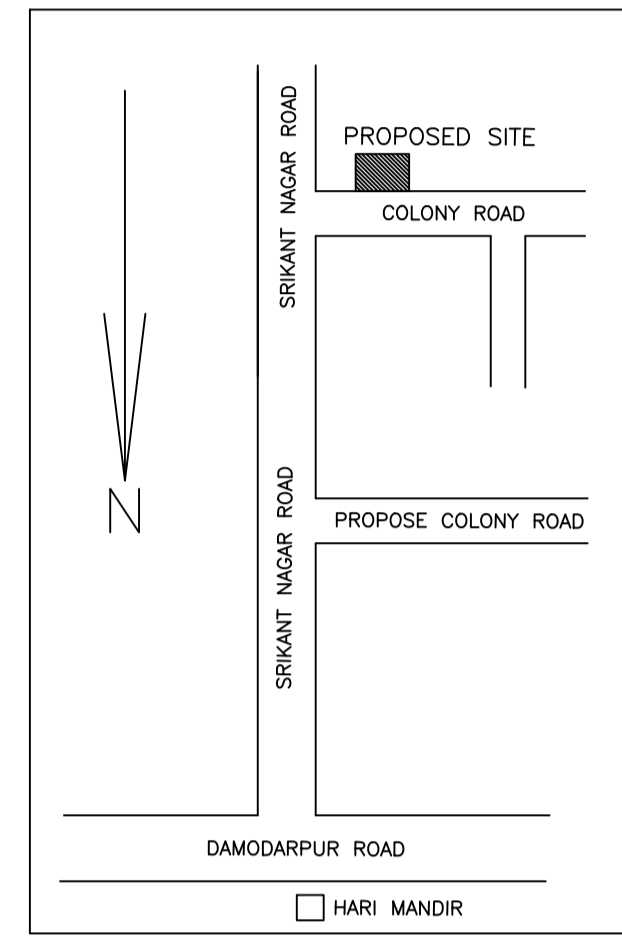
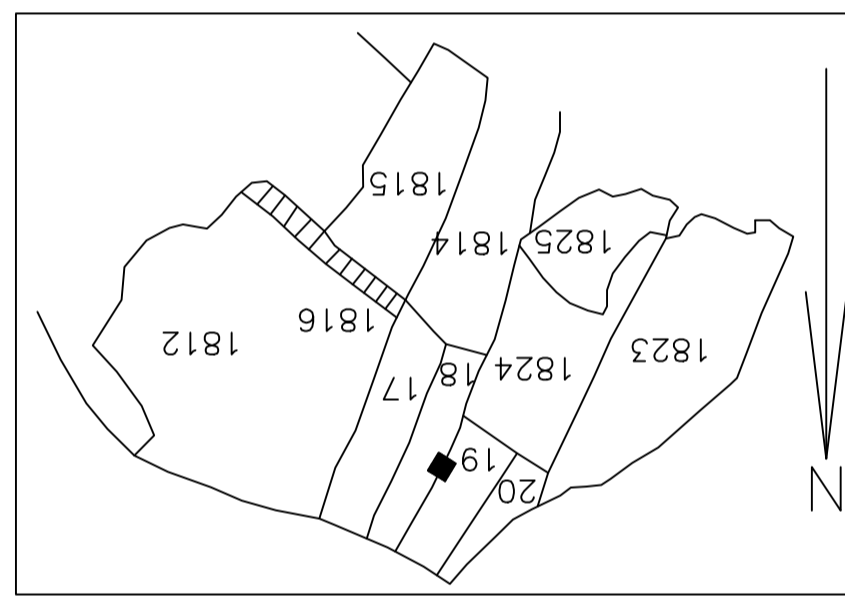

SECTION ON X-X

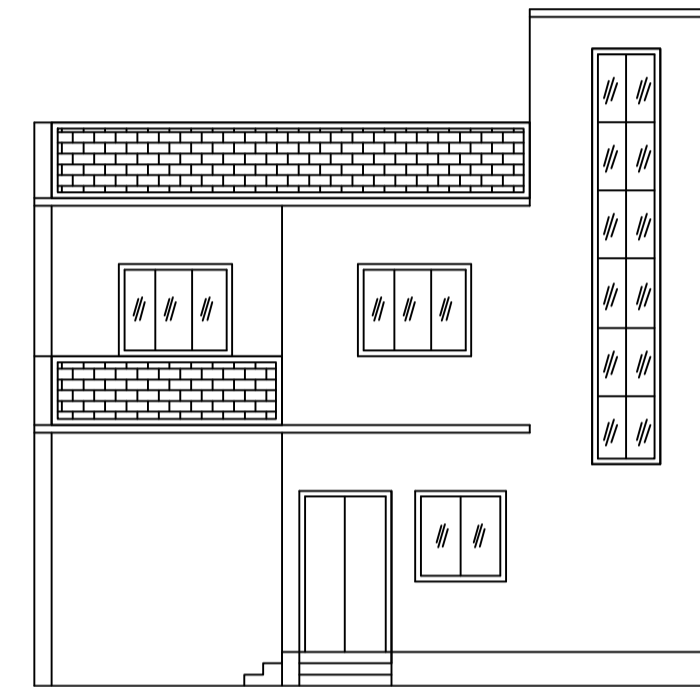

FRONT ELEVATION

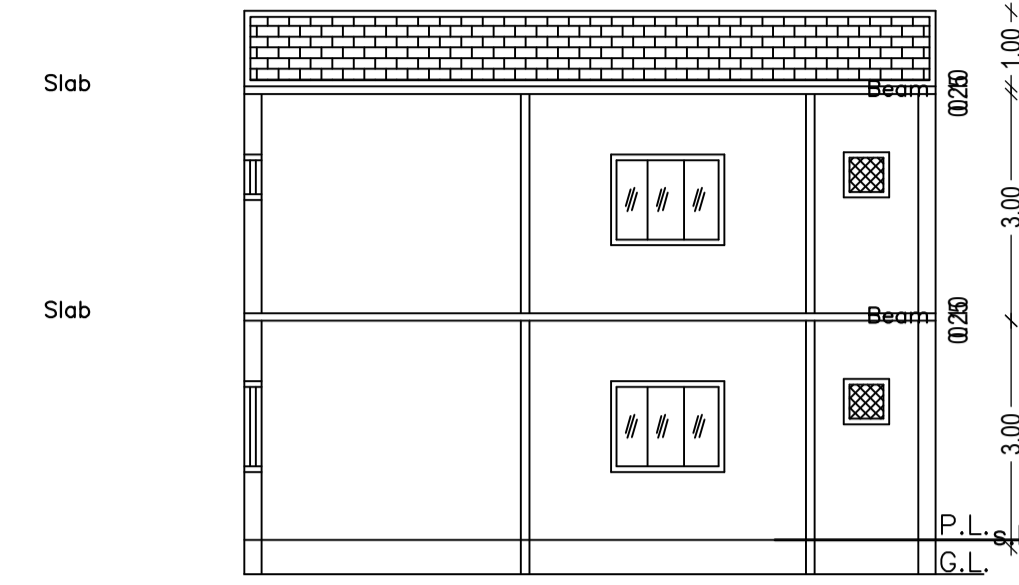

SECTION ON Y-Y

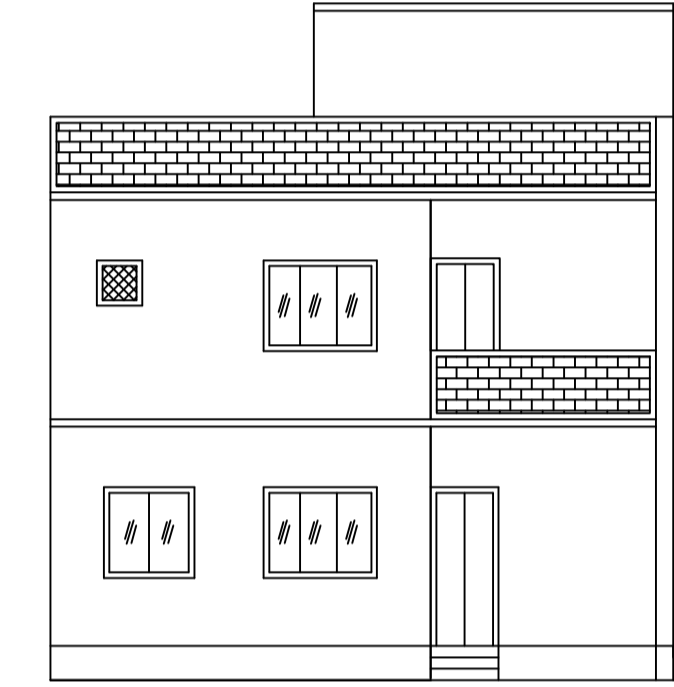

LEFT SIDE ELEVATION

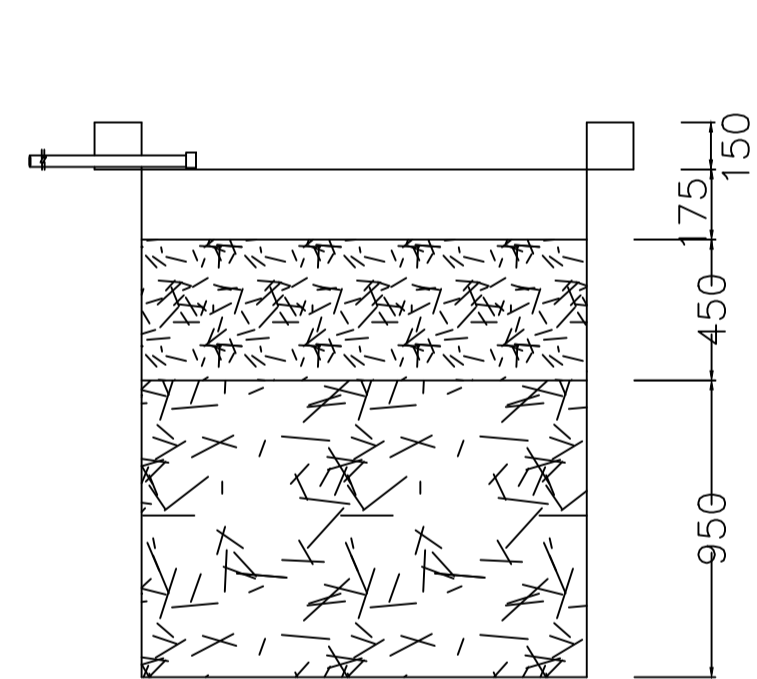

SECTION AT Y-Y

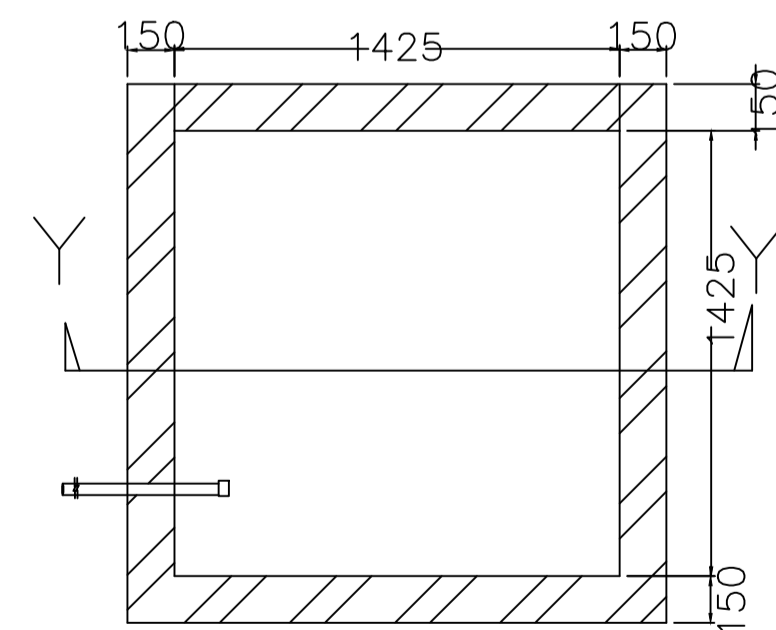

PLAN OF RECHARGE WELL

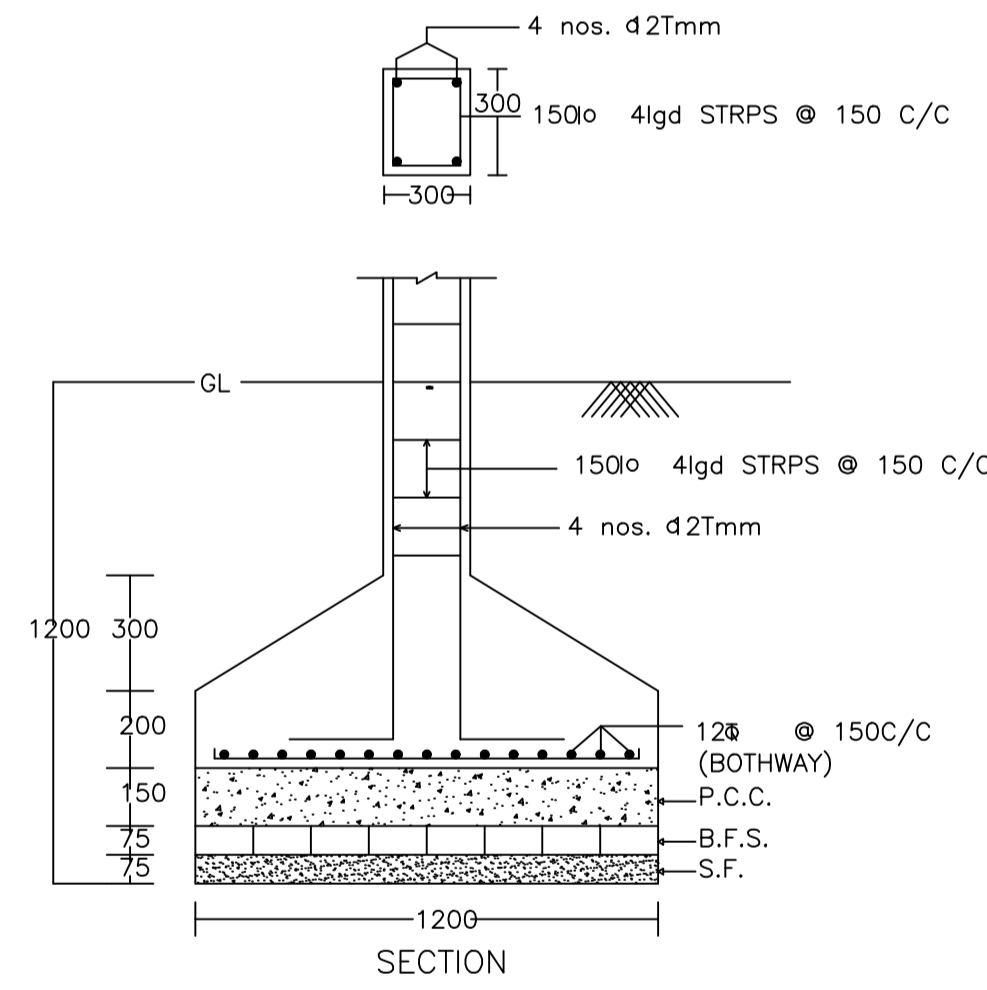

SECTION

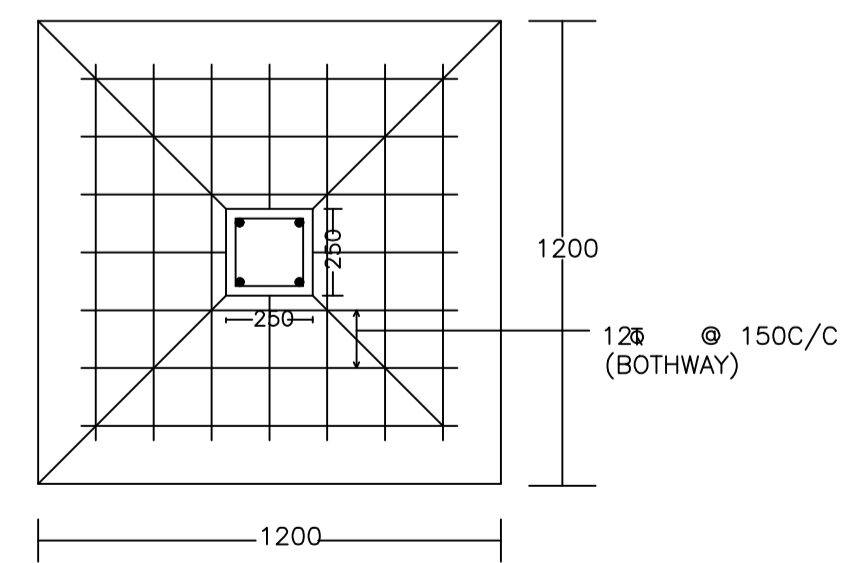

PLAN

DETAIL OF COLUMNS

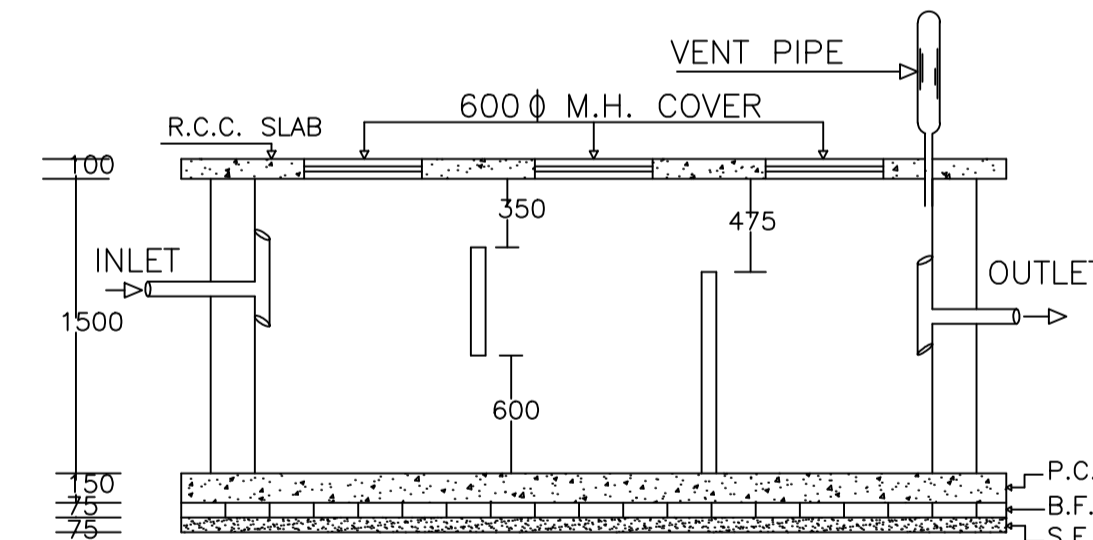

PLAN OF SEPTIC TANK

SCHEDULE OF DOOR:

BUILDING NAME	NAME	LENGTH	HEIGHT	NOS
AA (AA)	d	0.76	2.10	03
AA (AA)	d	0.90	2.10	02
AA (AA)	d	0.91	2.10	03
AA (AA)	d	1.05	2.10	01
AA (AA)	d	1.07	2.10	02
AA (AA)	d	1.22	2.10	01

SCHEDULE OF WINDOW/VENTILATION:

BUILDING NAME	NAME	LENGTH	HEIGHT	NOS
AA (AA)	w	0.60	1.20	03
AA (AA)	w	0.90	1.20	02
AA (AA)	w	1.20	1.20	01
AA (AA)	w	1.50	1.20	05
AA (AA)	w	1.70	1.20	01
AA (AA)	w	2.46	1.20	01

Building :AA (AA)

Floor Name	Total Built Up Area (Sq.mt.)	Proposed FAR Area (Sq.mt.)	Total FAR Area (Sq.mt.)	Total Consumed Additional FAR Area (Sq.mt.)	Trmt (No.)
Ground Floor	75.12	75.12	75.12	75.12	01
First Floor	75.12	75.12	75.12	75.12	00
Terrace Floor	0.00	0.00	0.00	0.00	00
Total :	150.24	150.24	150.24	150.24	01
Total Number of Same Buildings	1				
Total :	150.24	150.24	150.24	150.24	01

WATER HARVESTING

AREA STATEMENT MINERAL AREA DEVELOPMENT AUTHORITY	VERSION NO.: 1.0.62	VERSION DATE: 16/10/2020
PROJECT DETAIL:		
Region: JHARKHAND URBAN LOCAL BODIES	Plot Use: Residential	
District: DHANBAD	Plot SubUse: Bungalow/ Dwelling / Non Apartment	
Authority: MINERAL AREA DEVELOPMENT AUTHORITY	PlotNearby/ReligiousStructure: NA	
Inward No: MADA/BP/012/2022	Plot/SubPlot No: 951(old) 1818, 1819(new)	
Application Type: General Proposal	North: Road Width - 5.48	
Project Type: Building Permission	South: Plot No. - part of this plot	
Nature of Development: New	East: Plot No. - part of plot no. 1818	
Location of Development Area: Old Area	West: Plot No. - pankaj kumar jaiswal	
AREA DETAILS:		
AREA OF PLOT (Minimum)	(A)	128.65
NET AREA OF PLOT(Gross Plot Area - Deduction from Gross Plot area)	(A-Deductions)	128.65
Deduction for Balance Plot Area(from Gross Plot Area)		
Common Plot		21.95
Total		21.95
BALANCE AREA OF PLOT(Net Plot Area - Recreational/Amenity space)	(A-Deductions)	106.70
PLOT AREA FOR COVERAGE(Net Plot Area)	(A-Deductions)	128.65
Plot Area for FAR (Net Plot Area + Road/Widening Area)	(A-Deductions)	128.65
COVERAGE CHECK		
Permissible Coverage area (70.00 %)		90.05
Proposed Coverage Area (58.39 %)		75.12
Total Prop. Coverage Area (58.39 %)		75.12
Balance coverage area (11.60 %)		14.93
FAR CHECK		
Perm. FAR Area (1.50)		192.97
Total Perm. FAR area		192.97
Residential FAR		150.23
Proposed FAR Area		150.23
Total Proposed FAR Area		150.23
Consumed FAR (Factor)		1.17
Balance FAR Area		42.74
BUILT UP AREA CHECK		
Total Proposed BuiltUp Area		150.24
ARCHITECT (Regd)		
ENGINEER (Regd)		AMRESH KUMAR BHARTI
SUPERVISOR (Regd)		
OWNER (Regd)		sri mukesh kumar
DEVELOPMENT AUTHORITY		
		LOCAL BODY

COLOR INDEX	
PLOT BOUNDARY	Black
ABUTTING ROAD	Green
PROPOSED CONSTRUCTION	Red
COMMON PLOT	Yellow
ROAD WIDENING AREA	Blue
EXISTING (To be retained)	Light Blue
EXISTING (To be demolished)	Dark Blue

Buildingwise Floor FAR Details

Floor Name	Building Name		Total	
	Proposed Built Up Area (Sq.mt.)	Proposed FAR Area (Sq.mt.)	Total Proposed Built Up Area (Sq.mt.)	Total FAR Area (Sq.mt.)
Ground Floor	75.12	75.12	75.12	75.12
First Floor	75.12	75.12	75.12	75.12
Terrace Floor	0.00	0.00	0.00	0.00
Total :	150.24	150.24	150.24	150.24

Building USE/SUBUSE Details

Building Name	Building Use	Building SubUse	Building Structure
AA (AA)	Residential	Residential Bldg/Apartment	Non-Highrise

UnitBUA Table for Building :AA (AA)

FLOOR	Name	UnitBUA Type	UnitBUA Area	Carpet Area	No. of Rooms	No. of Tenement
GROUND FLOOR PLAN	SPLIT aa	FLAT	150.23	150.04	6	1
FIRST FLOOR PLAN	SPLIT aa	FLAT	0.00	0.00	6	0
Total:	-	-	150.23	150.04	12	1

FAR & Tenement Details (Table 4c-1)

Building	No. of Same Bldg	Total Built Up Area (Sq.mt.)	Proposed FAR Area (Sq.mt.)	Total FAR Area (Sq.mt.)	Total Consumed Additional FAR Area (Sq.mt.)	Trmt (No.)
AA (AA)	1	150.24	150.24	150.24	150.24	01
Grand Total :	1	150.24	150.24	150.24	150.24	01

LTP NAME AND SIGNATURE	STRUCTURAL ENG'S NAME AND SIGNATURE	BUILDER NAME AND SIGNATURE	DIGITAL SIGNATURE
AMRESH KUMAR BHARTI MADA/ENG/0003/2021			

Proposal Basic Information	
Proposal File No.	MADA/EP/0012/2022
Owner Name	sri mukesh kumar
Khata No	52(old) 130(new)
Plot No	951(old) 1818, 1819(new)
Village Name	Damodarpur
Use	Residential
SubUse	Bungalow/ Dwelling / Non Apartment

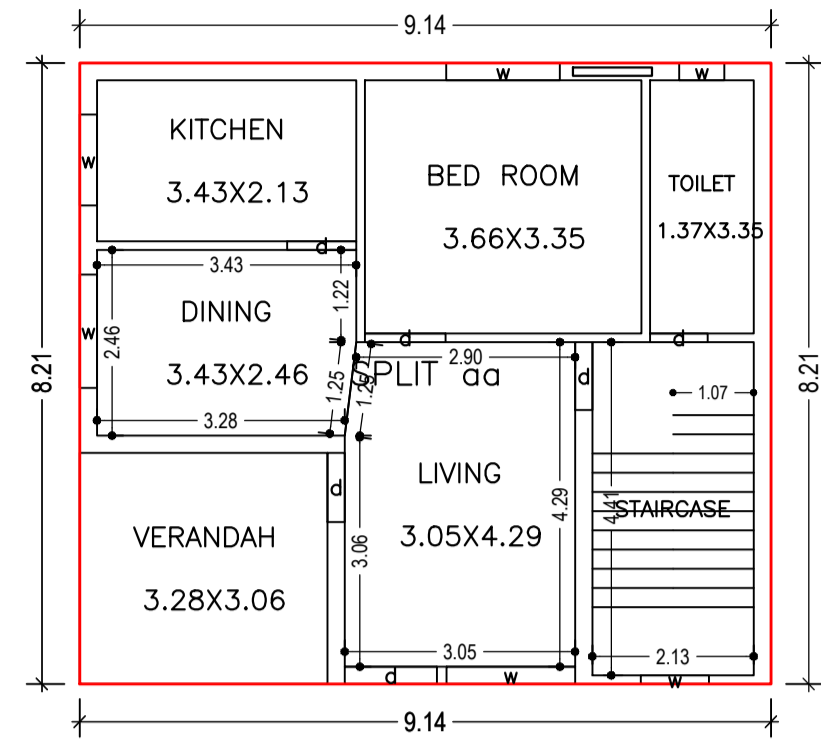

GROUND FLOOR PLAN
(Proposed)
(SCALE 1:100)

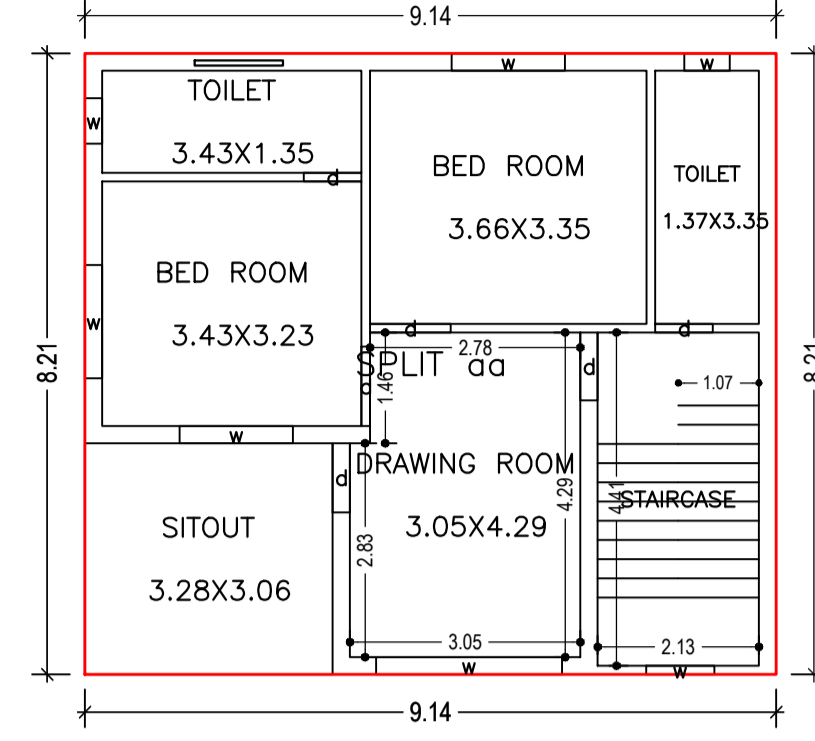

FIRST FLOOR PLAN
(Proposed)
(SCALE 1:100)

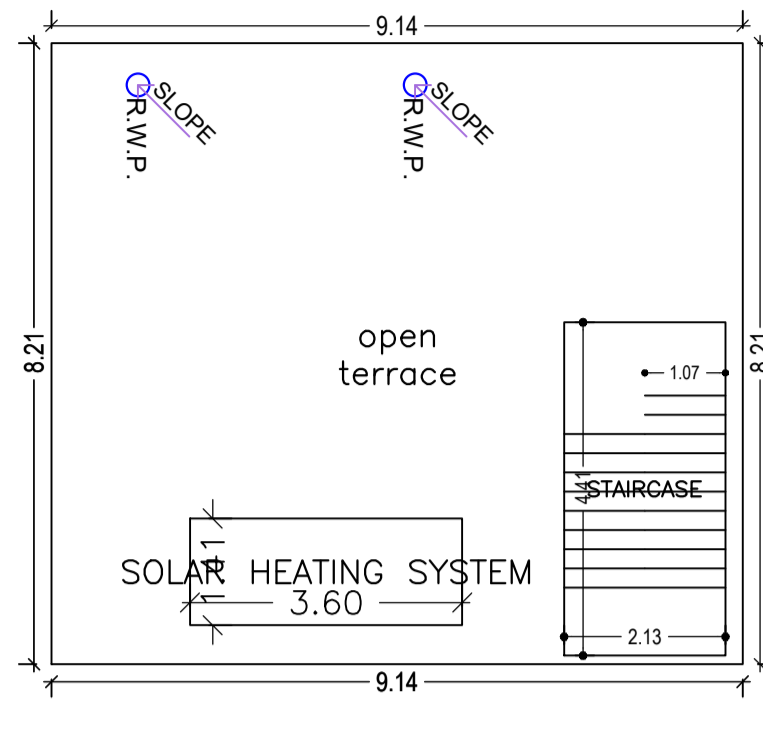

TERRACE FLOOR PLAN
(SCALE 1:100)

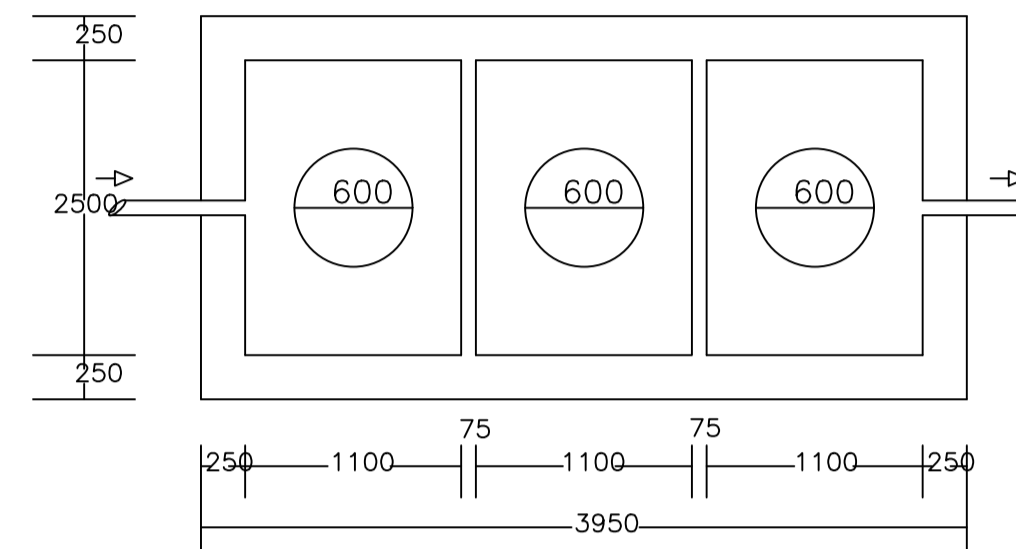
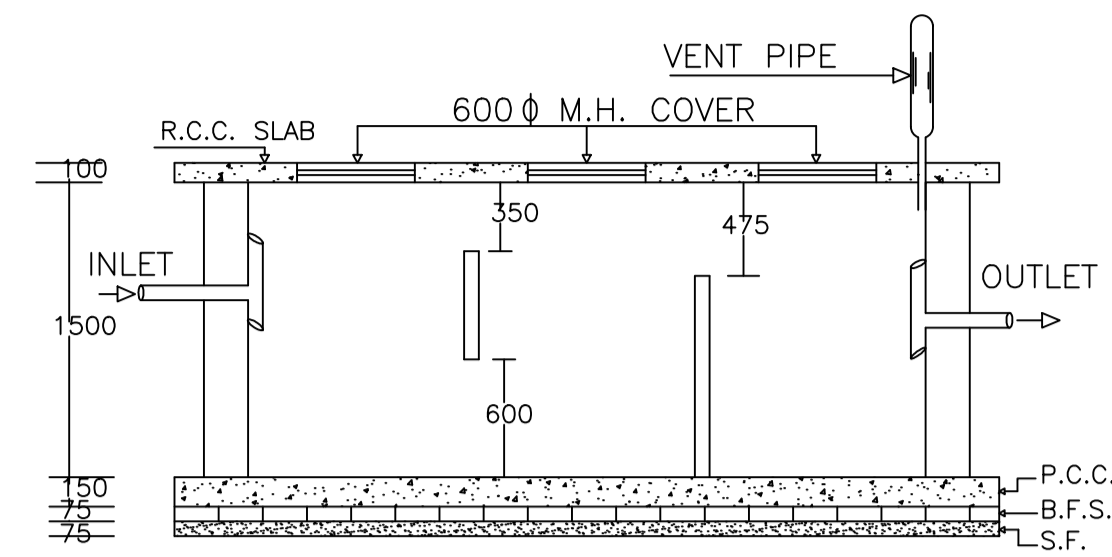

PLAN OF SEPTIC TANK

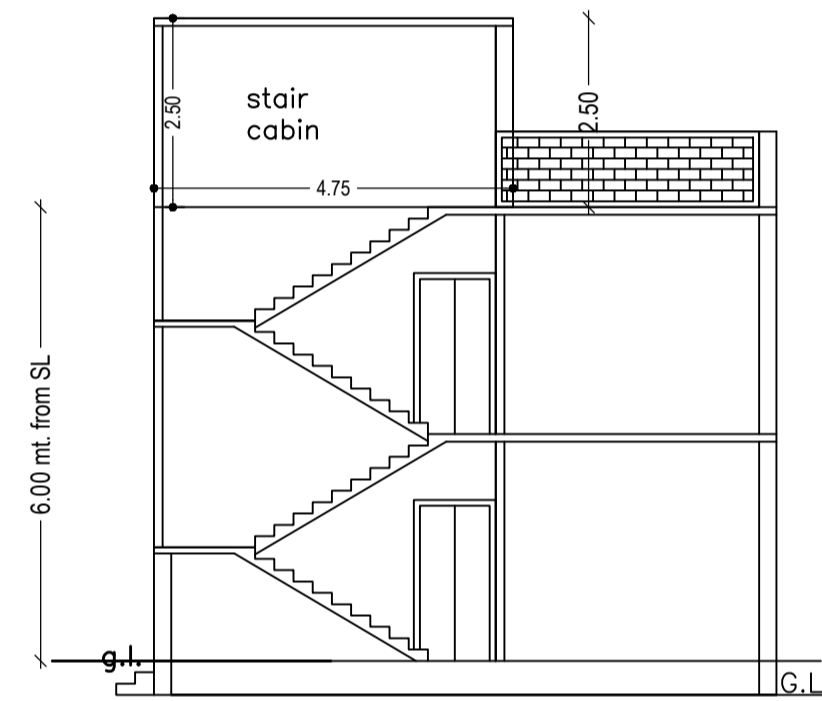
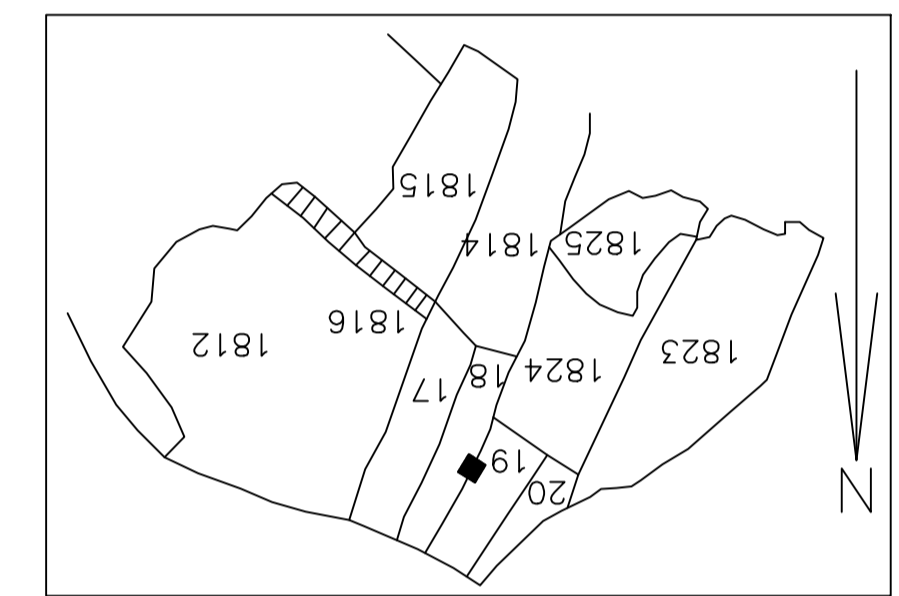

SECTION ON X-X

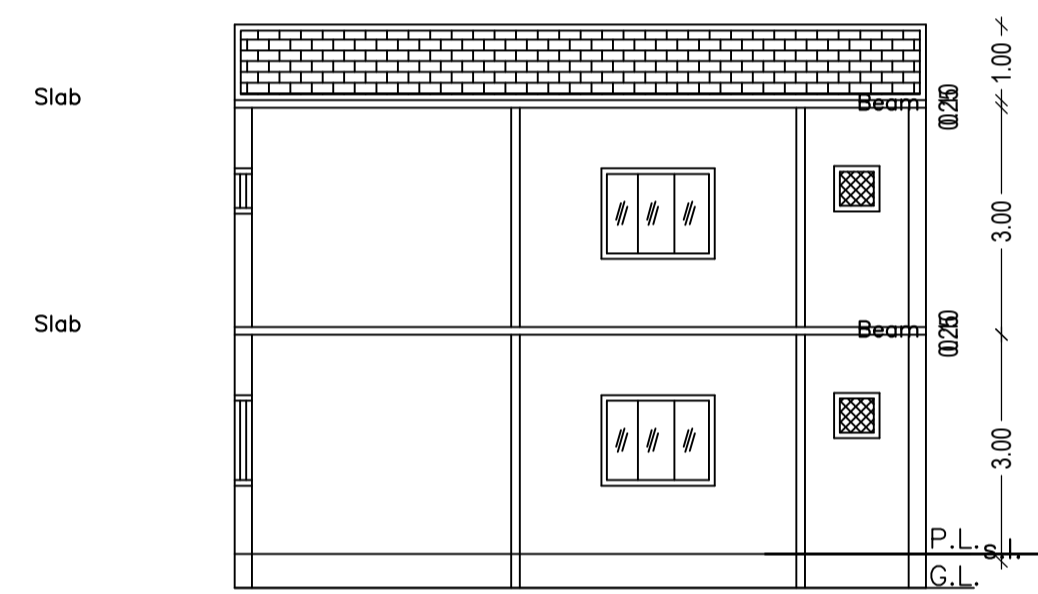

SECTION ON Y-Y

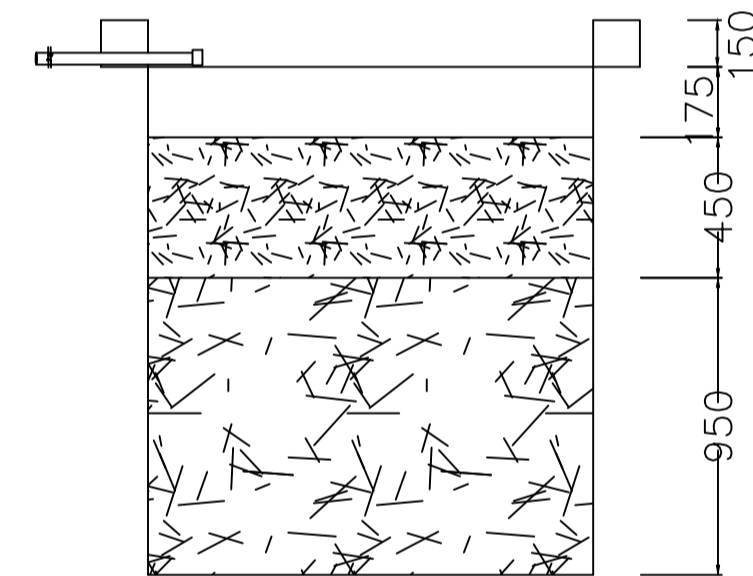

SECTION AT Y-Y

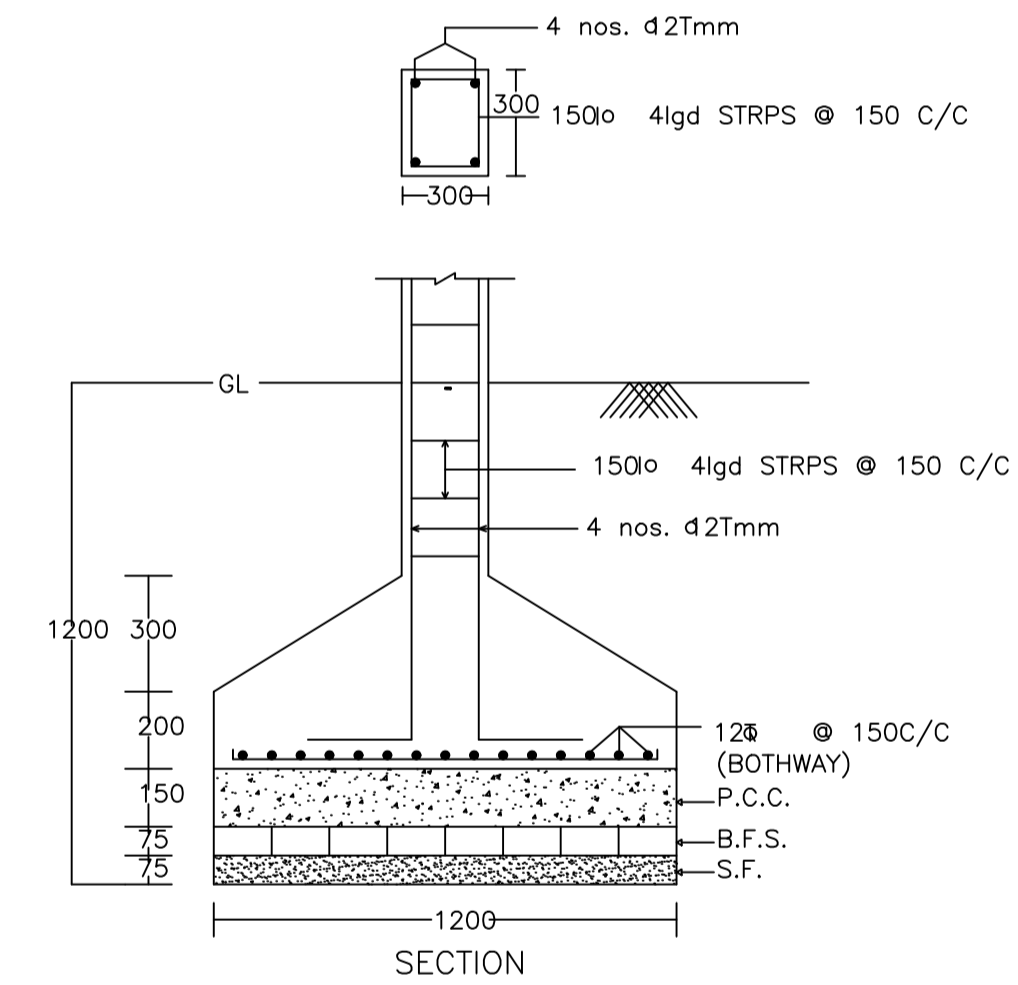

SECTION

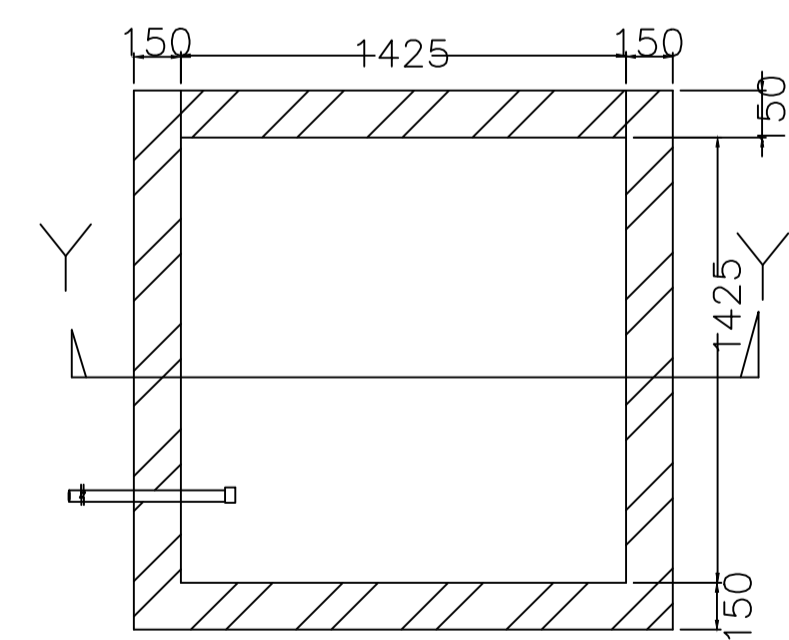

PLAN OF RECHARGE WELL

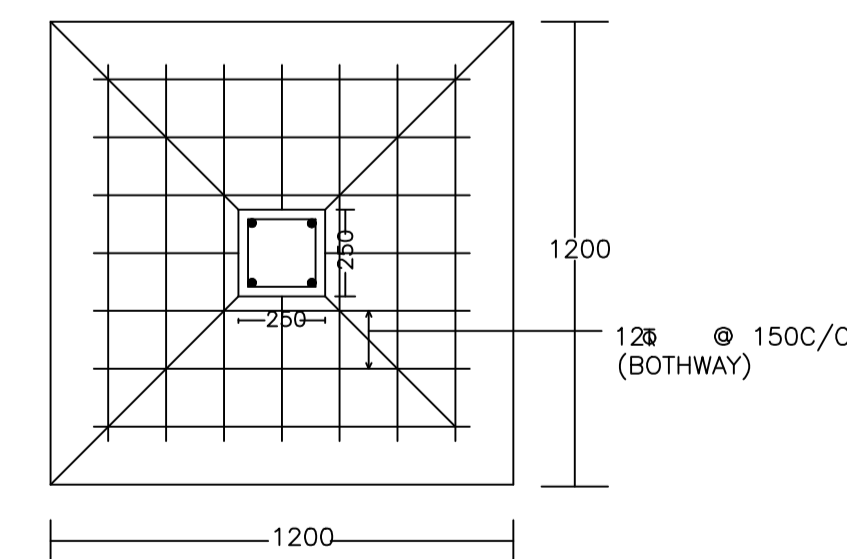

PLAN

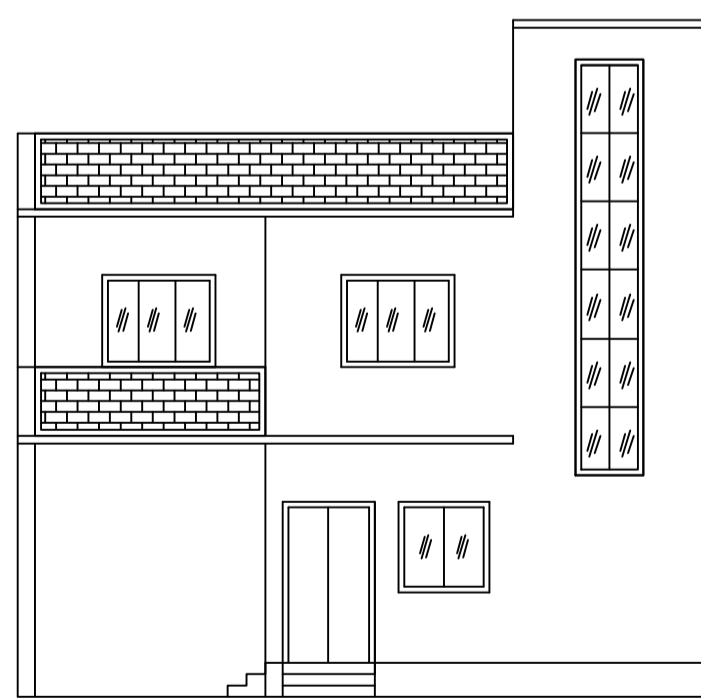
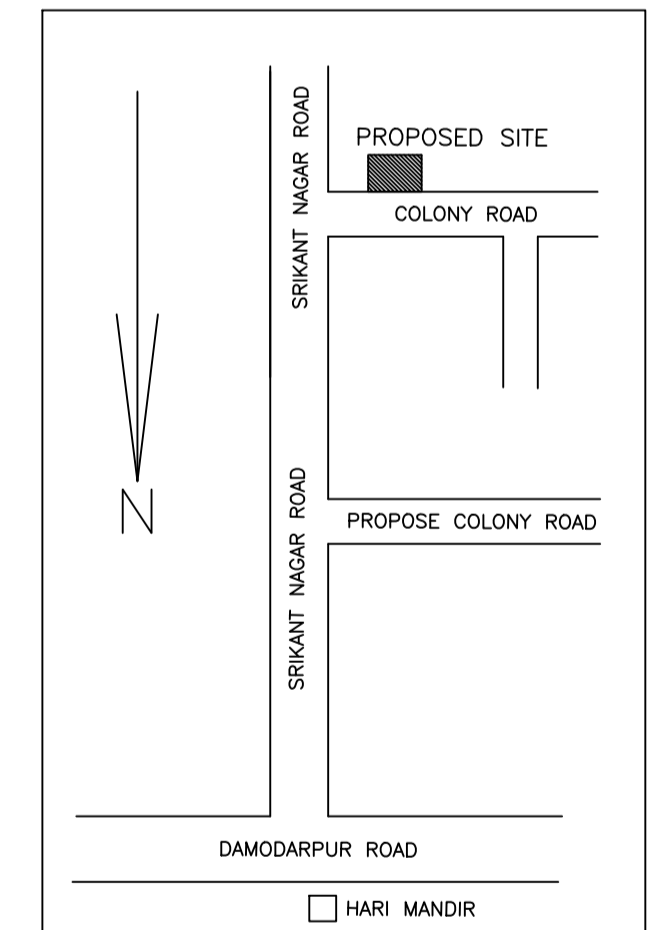

FRONT ELEVATION

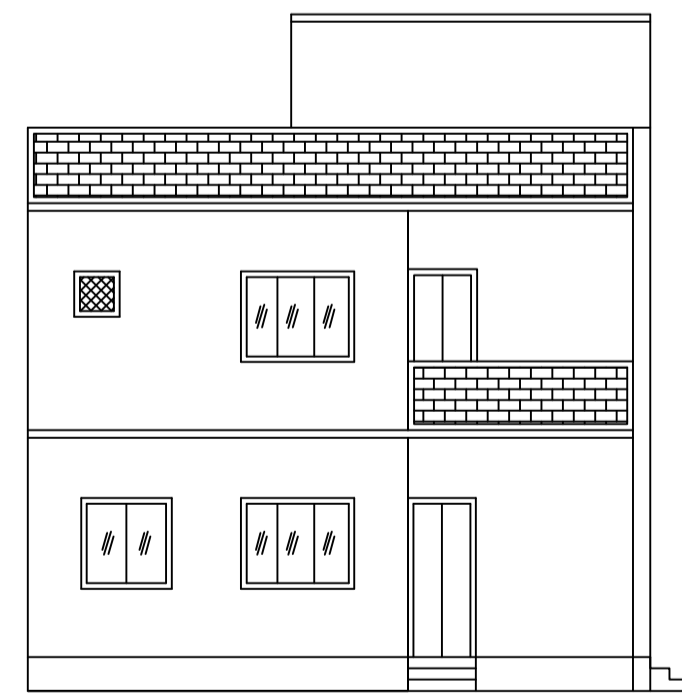

LEFT SIDE ELEVATION

WATER HARVESTING

DETAIL OF COLUMNS

LTP NAME AND SIGNATURE	STRUCTURAL ENG'S NAME AND SIGNATURE	BUILDER NAME AND SIGNATURE	DIGITAL SIGNATURE
AMRESH KUMAR BHARTI MADA/ENG/0003/2021			