

SITE PLAN

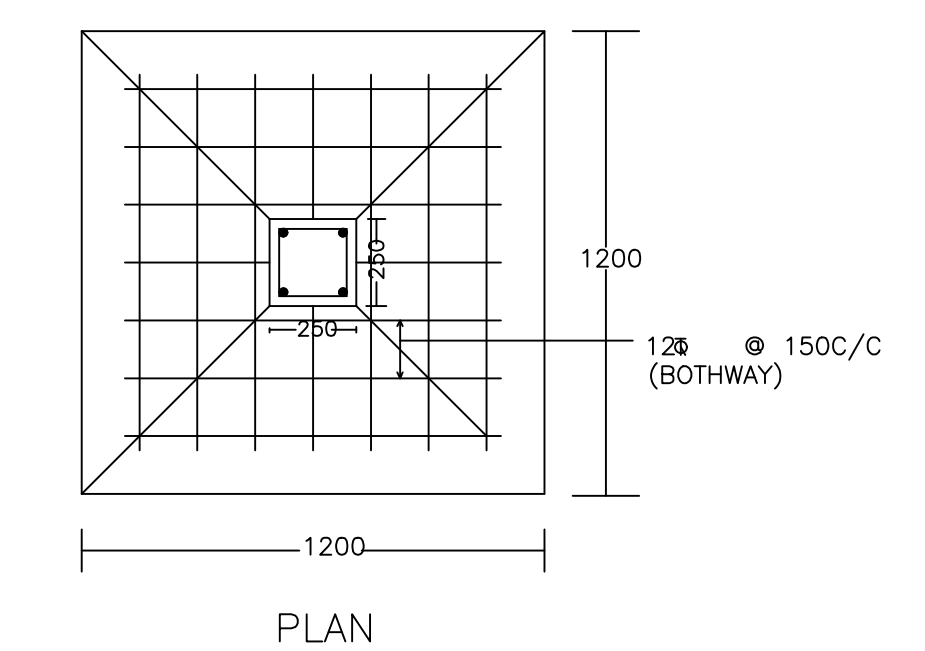

DETAIL OF COLUMNS

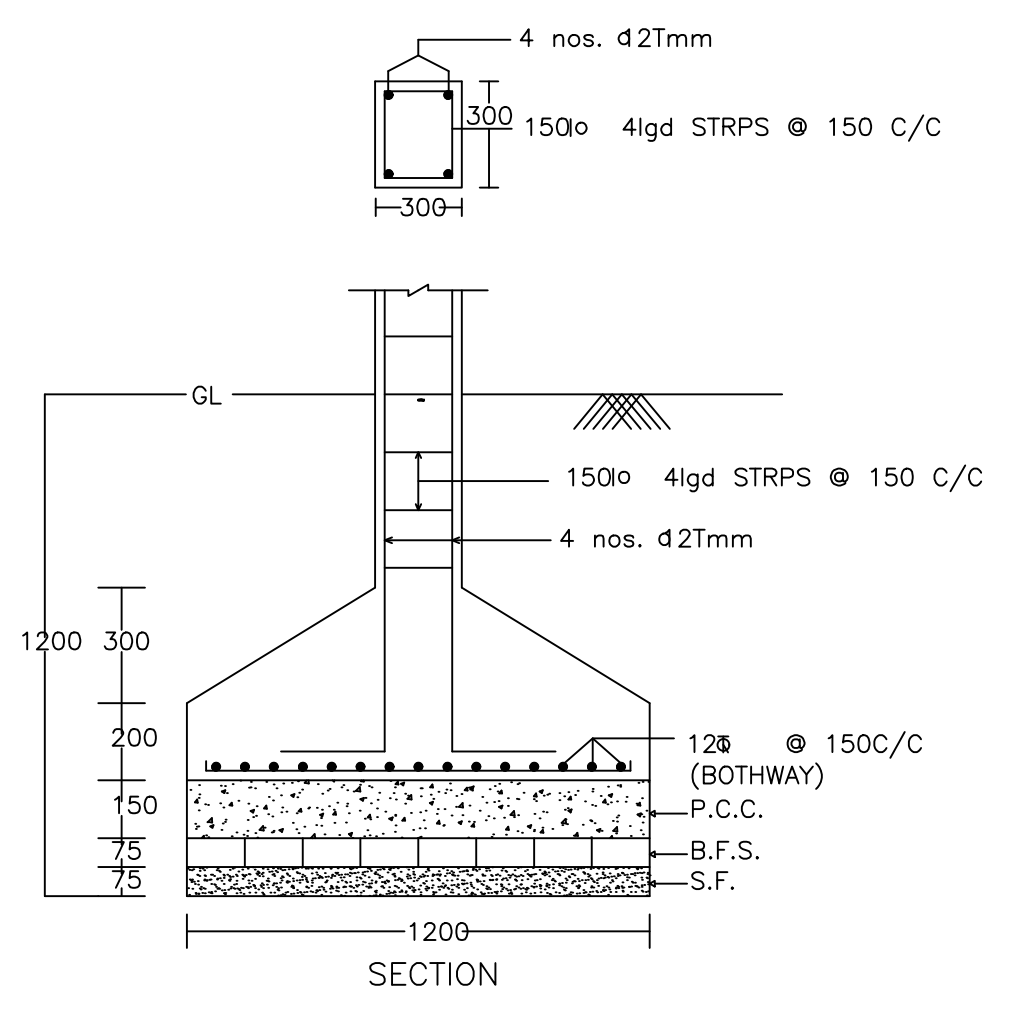
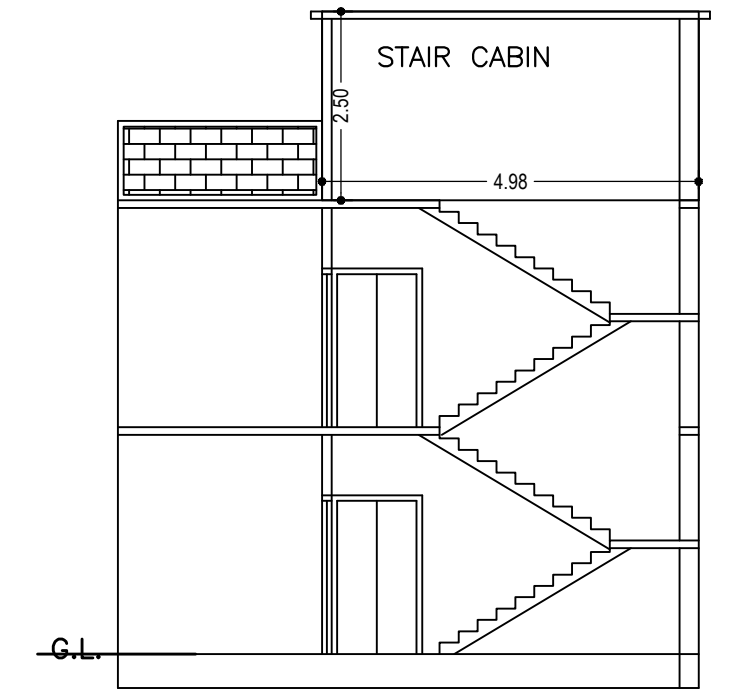

SECTION ON X-X

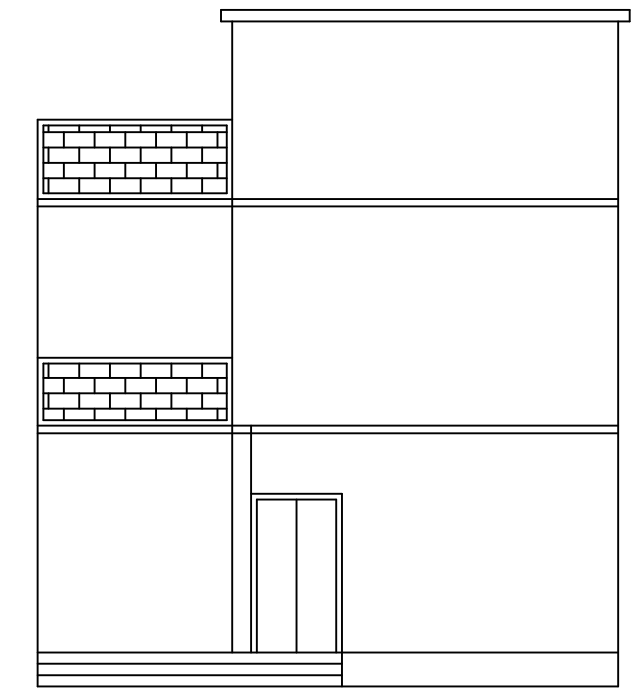

FRONT ELEVATION

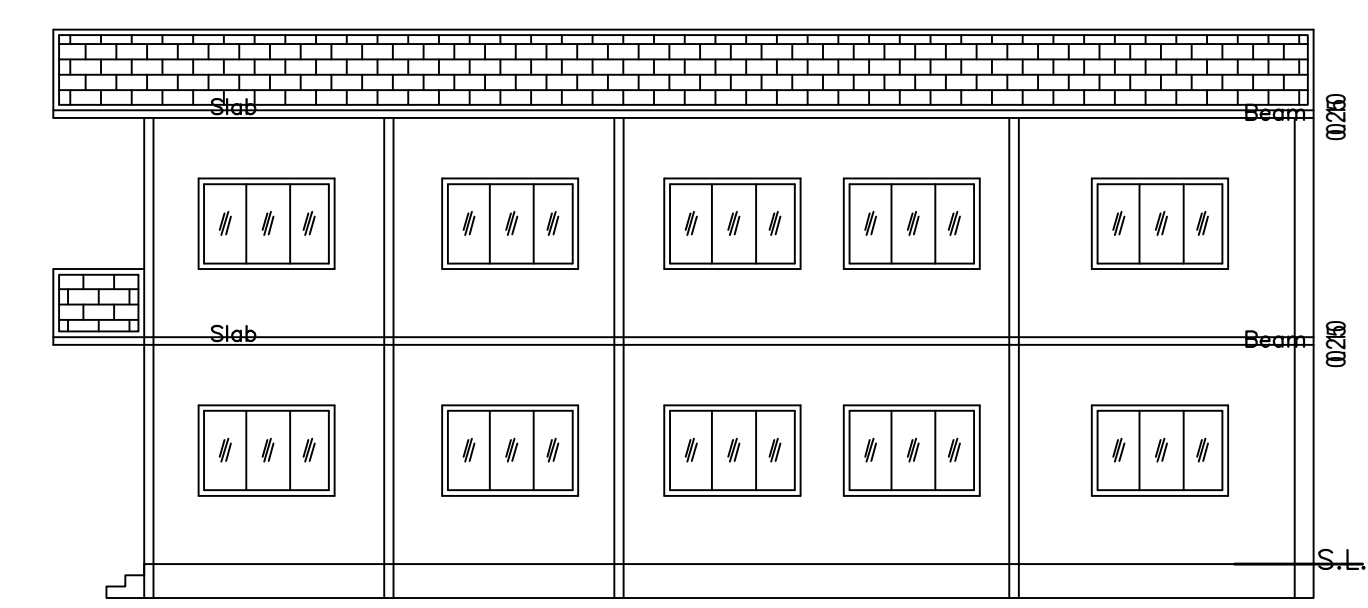

SECTION ON Y-Y

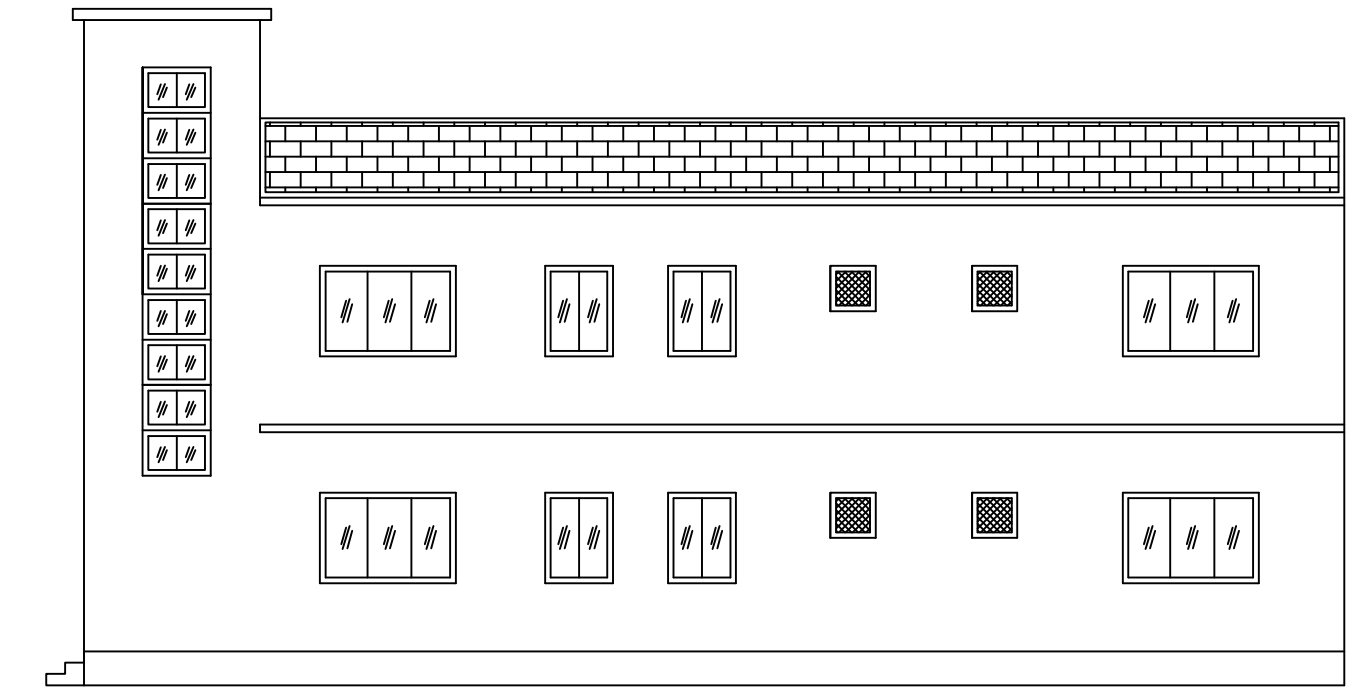

RIGHT SIDE ELEVATION

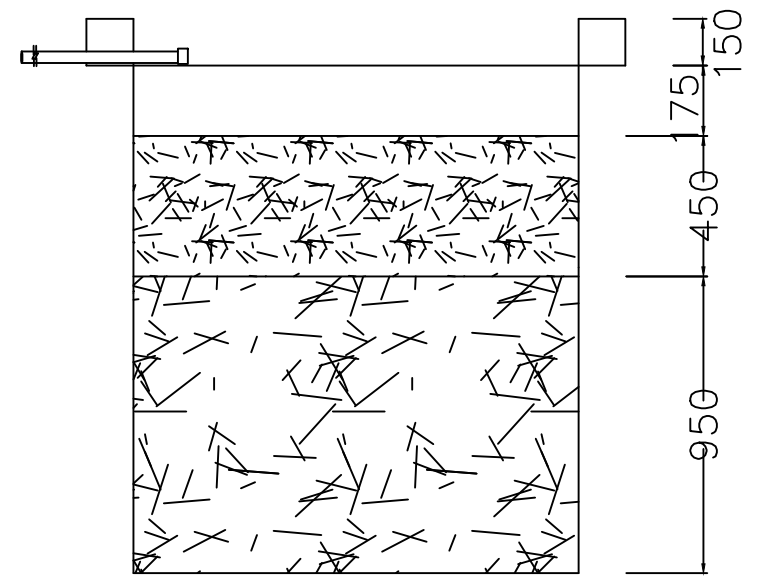

SECTION AT Y-Y

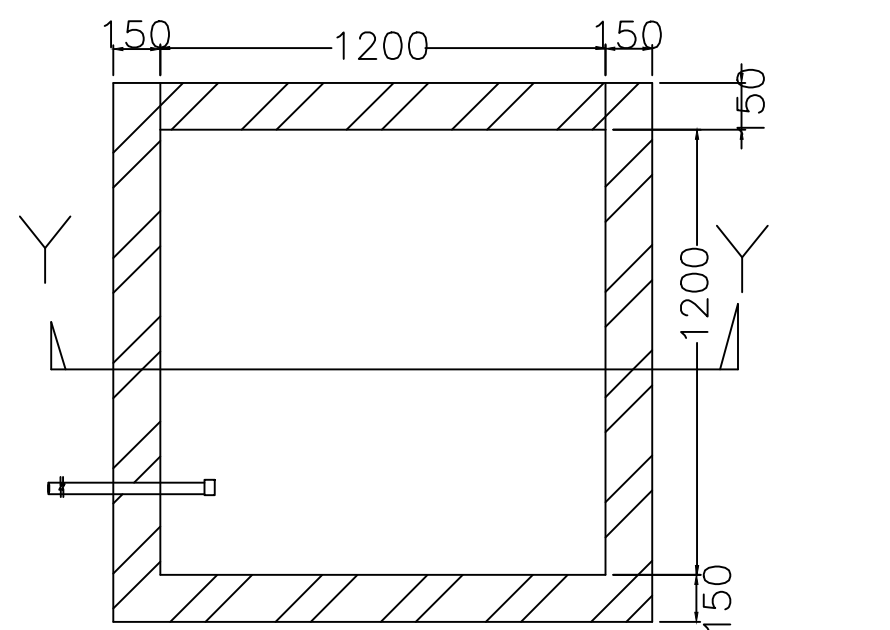

PLAN OF RECHARGE WELL

SCHEDULE OF DOOR:

BUILDING NAME	NAME	LENGTH	HEIGHT	NOS
AA (AA)	D	0.90	2.10	10
AA (AA)	D	0.95	2.10	02
AA (AA)	D	1.05	2.10	06
AA (AA)	D	1.20	2.10	02
AA (AA)	D	1.50	2.10	02

SCHEDULE OF WINDOW/VENTILATION:

BUILDING NAME	NAME	LENGTH	HEIGHT	NOS
AA (AA)	V	0.60	1.20	04
AA (AA)	W	0.90	1.20	06
AA (AA)	W	1.80	1.20	18

Building :AA (AA)

Floor Name	Total Built Up Area (Sq.mt.)	Proposed FAR Area (Sq.mt.)	Total FAR Area (Sq.mt.)	Total Consumed Additional FAR Area (Sq.mt.)	Tnmt (No.)
Ground Floor	127.07	127.07	127.07	127.07	01
First Floor	127.07	127.07	127.07	127.07	00
Terrace Floor	0.00	0.00	0.00	0.00	00
Total :	254.14	254.14	254.14	254.14	01
Total Number of Same Buildings :	1				
Total :	254.14	254.14	254.14	254.14	01

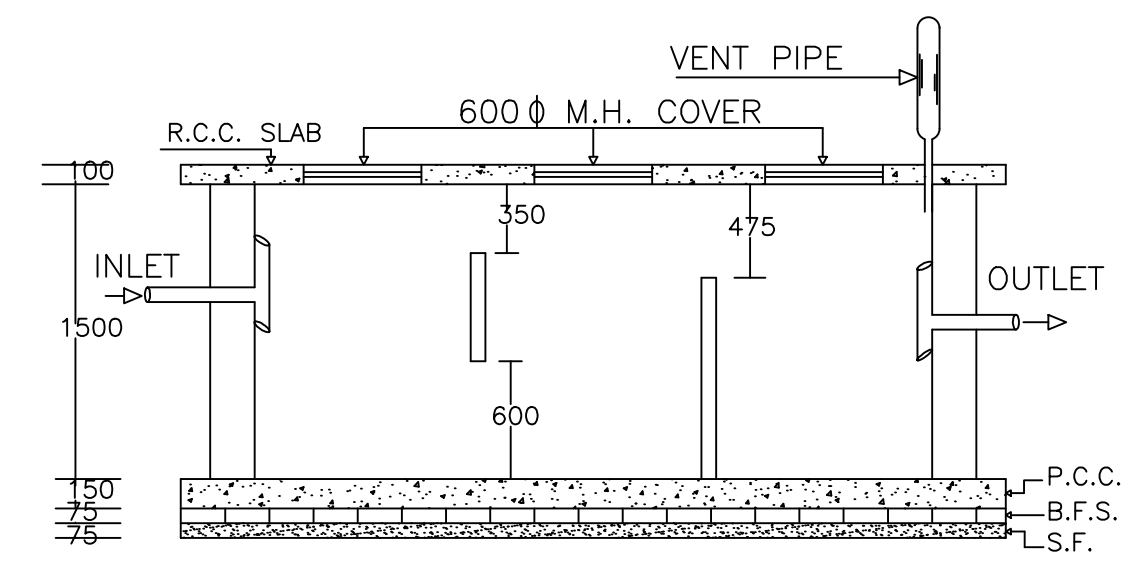

PLAN OF SEPTIC TANK

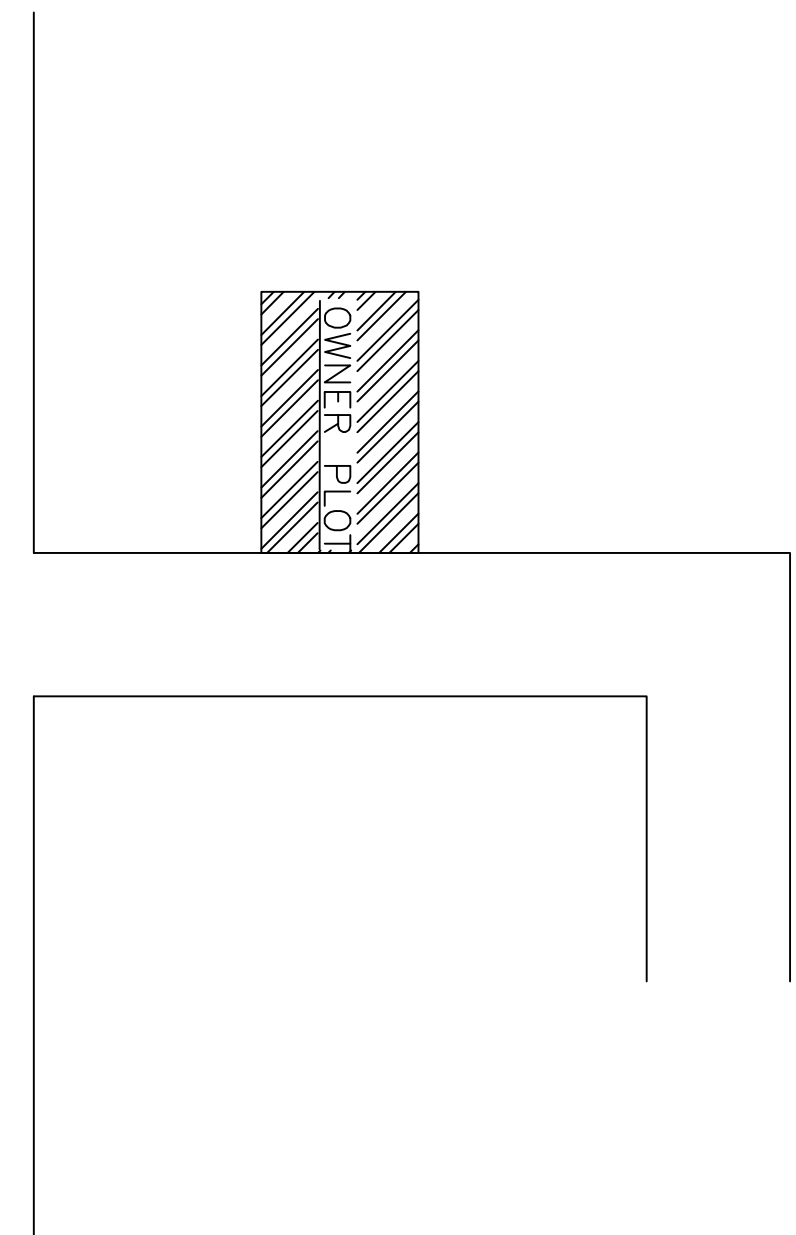

LOCATION PLAN

Proposal Basic Information

Proposal File No.	MADA/BP/0037/2022
Owner Name	SMT. SWEETY SHARMA.
Khata No	11 (Old), 61 (New)
Plot No	1009 (Old), 106 (New)
Village Name	Bagula
Use	Residential
SubUse	Bungalow/ Dwelling / Non Apartment

AREA STATEMENT MINERAL AREA DEVELOPMENT AUTHORITY	VERSION NO.: 1.0.62
	VERSION DATE: 16/10/2020
PROJECT DETAIL:	
Region: JHARKHAND URBAN LOCAL BODIES	Plot Use: Residential
District: DHANBAD	Plot SubUse: Bungalow/ Dwelling / Non Apartment
Authority: MINERAL AREA DEVELOPMENT AUTHORITY	PlotNearby/ReligiousStructure: NA
Inward No: MADA/BP/0037/2022	Plot/SubPlot No: 1009 (Old), 106 (New)
Application Type: General Proposal	North: Plot No. - NIZ
Project Type: Building Permission	South: Plot No. - NIZ
Nature of Development: New	East: Road Width - 4.87
Location of Development Area: Old Area	West: Plot No. - OLD PLOT NO. 1053
AREA DETAILS:	SQ.MT.
AREA OF PLOT (Minimum)	(A) 198.47
NET AREA OF PLOT(Gross Plot Area - Deduction from Gross Plot area)	(A-Deductions) 198.47
Deduction for Balance Plot Area(from Gross Plot Area)	
Common Plot Total	30.31
BALANCE AREA OF PLOT(Net Plot Area - Recreational/Amenity space)	(A-Deductions) 168.16
PLOT AREA FOR COVERAGE(Net Plot Area)	(A-Deductions) 198.47
Plot Area for FAR (Net Plot Area + RoadWidening Area)	(A-Deductions) 198.47
COVERAGE CHECK	
Permissible Coverage area (70.00 %)	138.93
Proposed Coverage Area (64.02 %)	127.07
Total Prop. Coverage Area (64.02 %)	127.07
Balance coverage area (5.98 %)	11.86
FAR CHECK	
Perm. FAR Area (1.80)	357.25
Total Perm. FAR area	357.25
Residential FAR	254.13
Proposed FAR Area	254.13
Total Proposed FAR Area	254.13
Consumed FAR (Factor)	1.28
Balance FAR Area	103.12
BUILT UP AREA CHECK	
Total Proposed BuiltUp Area	254.14
ARCHITECT (Regd)	Partha Pal
ENGINEER (Regd)	
SUPERVISOR (Regd)	
OWNER (Regd)	SMT. SWEETY SHARMA.
DEVELOPMENT AUTHORITY	LOCAL BODY

COLOR INDEX

PLOT BOUNDARY	Black
ABUTTING ROAD	Green
PROPOSED CONSTRUCTION	Red
COMMON PLOT	Yellow
ROAD WIDENING AREA	Blue
EXISTING (To be retained)	Light Blue
EXISTING (To be demolished)	Dark Blue

Buildingwise Floor FAR Details

Floor Name	Building Name		Total	
	Proposed Built Up Area (Sq.mt.)	Proposed FAR Area (Sq.mt.)	Total Proposed Built Up Area (Sq.mt.)	Total FAR Area (Sq.mt.)
Ground Floor	127.07	127.07	127.07	127.07
First Floor	127.07	127.07	127.07	127.07
Terrace Floor	0.00	0.00	0.00	0.00
Total :	254.14	254.14	254.14	254.14

Building USE/SUBUSE Details

Building Name	Building Use	Building SubUse	Building Structure
AA (AA)	Residential	Bungalow/ Dwelling / Non Apartment	Non-Highrise

UnitBUA Table for Building :AA (AA)

FLOOR	Name	UnitBUA Type	UnitBUA Area	Carpet Area	No. of Rooms	No. of Tenement
GROUND FLOOR PLAN	SPLIT AA	FLAT	254.13	253.87	12	1
FIRST FLOOR PLAN	SPLIT AA	FLAT	0.00	0.00	12	0
Total:	-	-	254.13	253.87	24	1

FAR & Tenement Details (Table 4c-1)

Building	No. of Same Bldg	Total Built Up Area (Sq.mt.)	Proposed FAR Area (Sq.mt.)	Total FAR Area (Sq.mt.)	Total Consumed Additional FAR Area (Sq.mt.)	Tnmt (No.)
AA (AA)	1	254.14	254.14	254.14	254.14	01
Grand Total :	1	254.14	254.14	254.14	254.14	01

LTP NAME AND SIGNATURE	STRUCTURAL ENG'S NAME AND SIGNATURE	BUILDER NAME AND SIGNATURE	DIGITAL SIGNATURE
Partha Pal MADA/ENG/0002/2019			

Proposal Basic Information

Proposal File No.	MADA/BP/0037/2022
Owner Name	SMT. SWEETY SHARMA.
Khata No	11 (Old), 61 (New)
Plot No	1009 (Old), 106 (New)
Village Name	Bagula
Use	Residential
SubUse	Bungalow/ Dwelling / Non Apartment

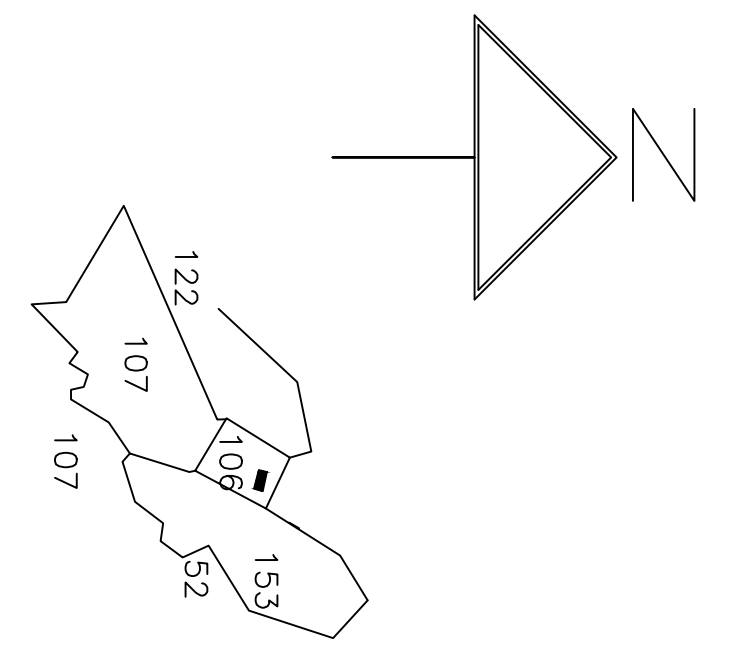
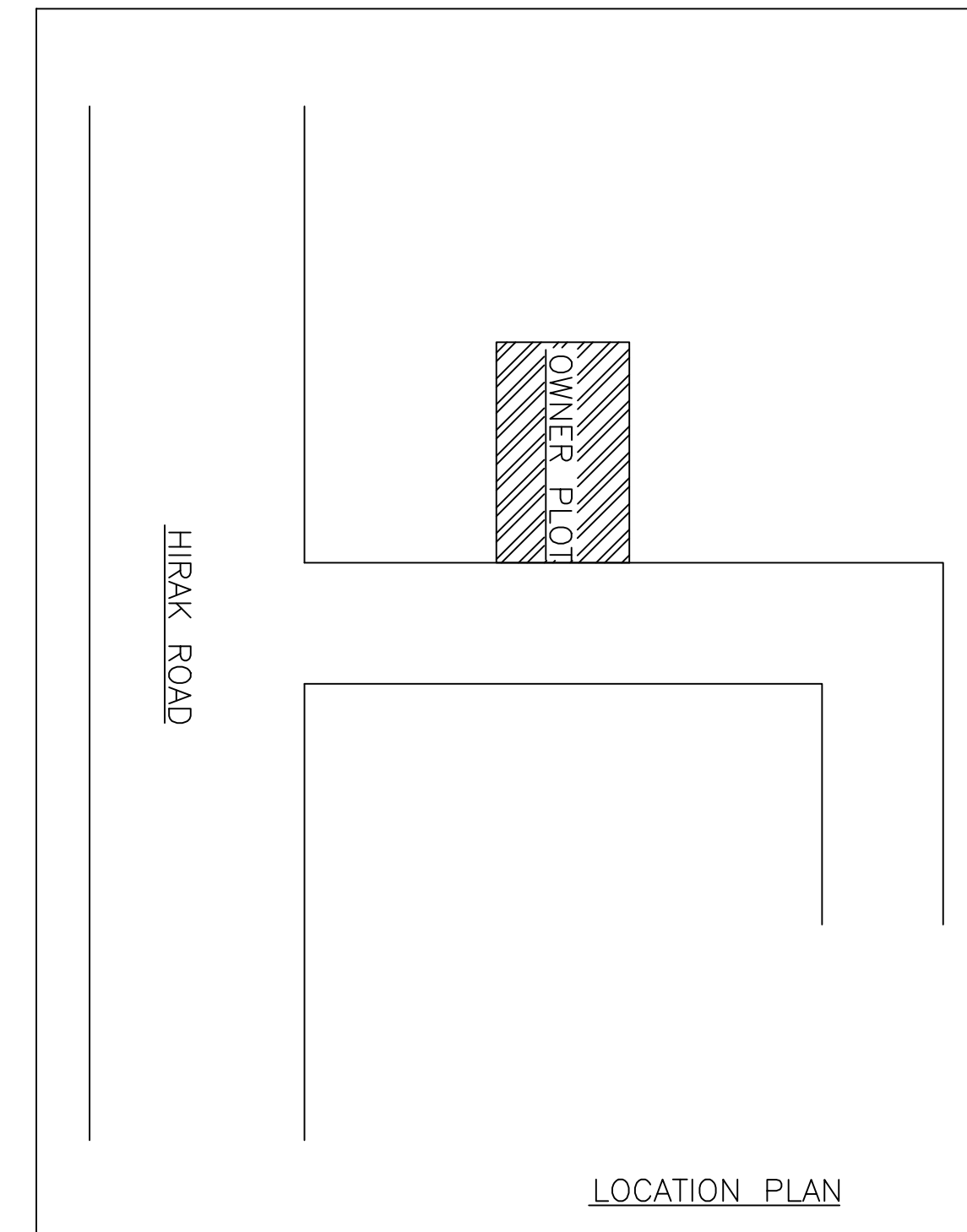
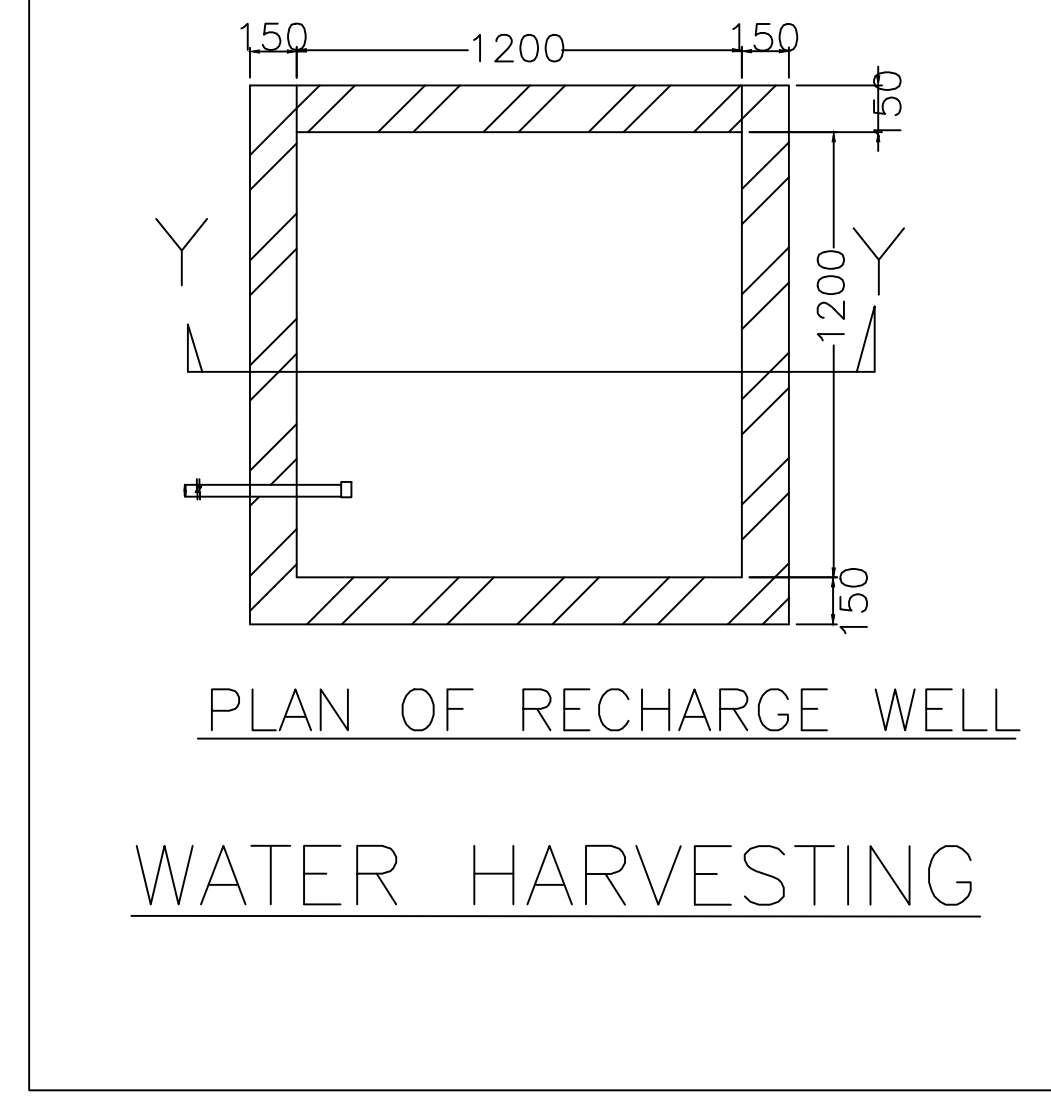
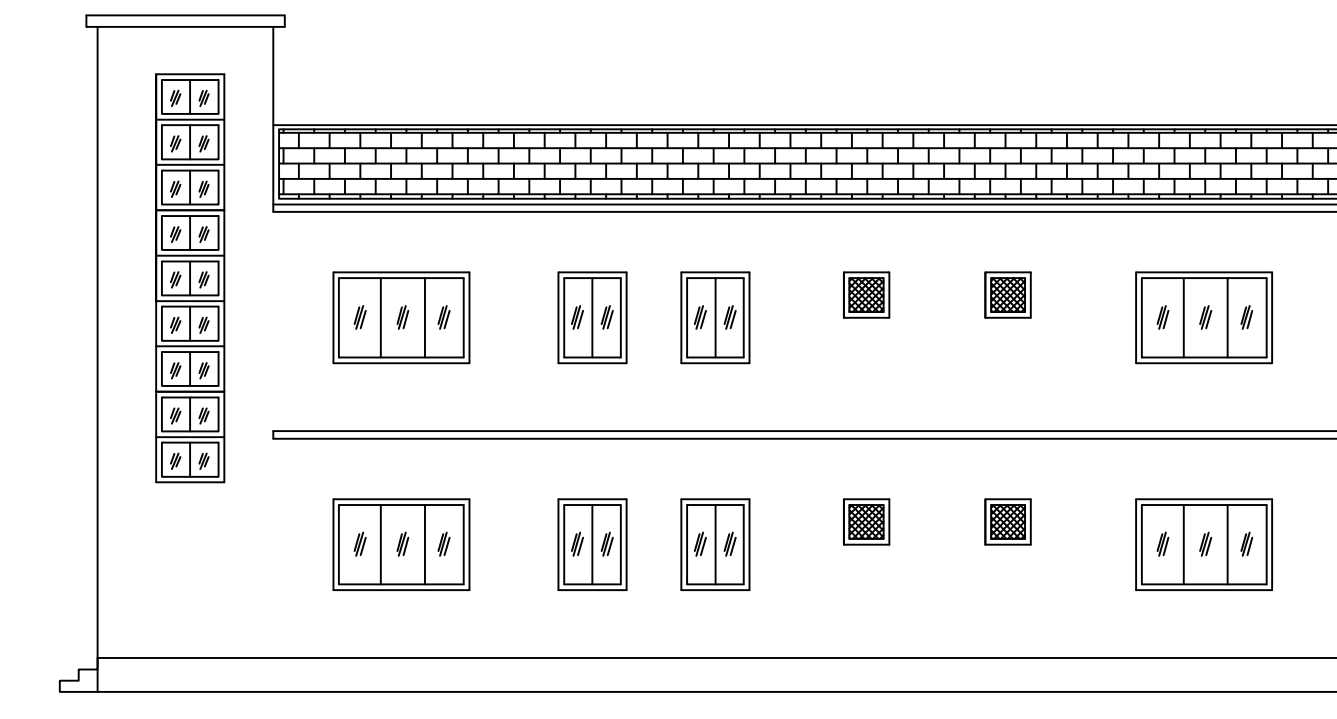
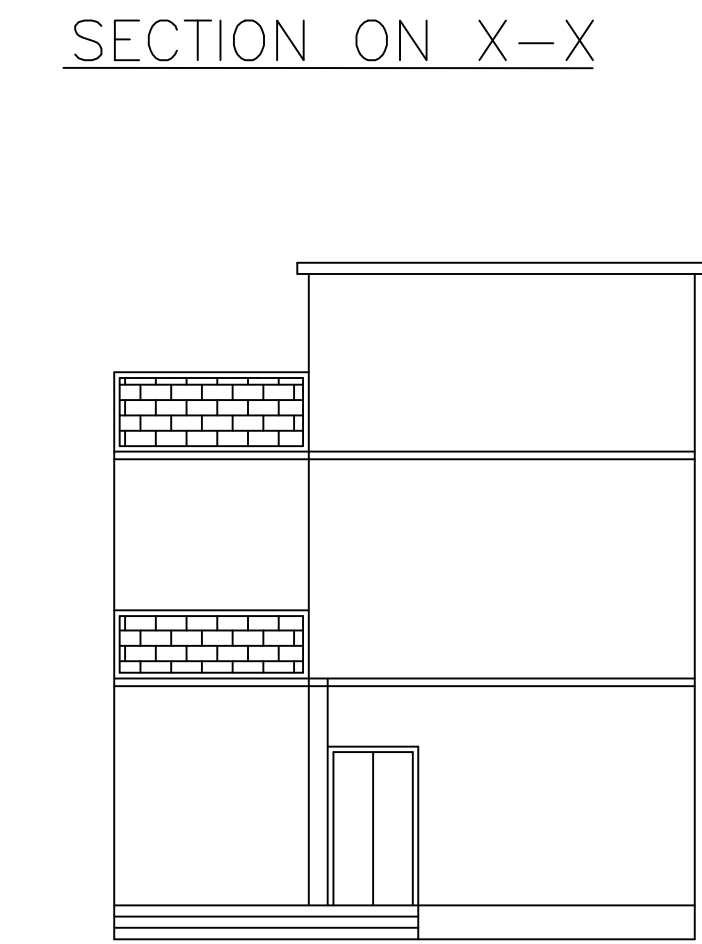
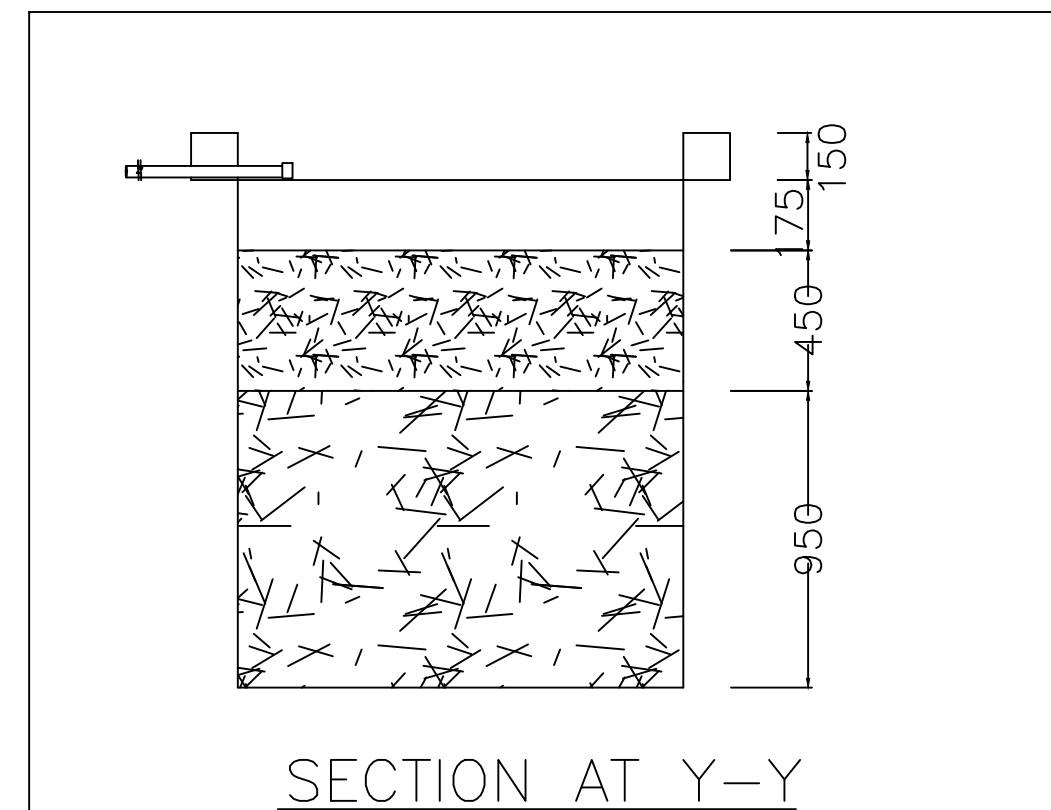
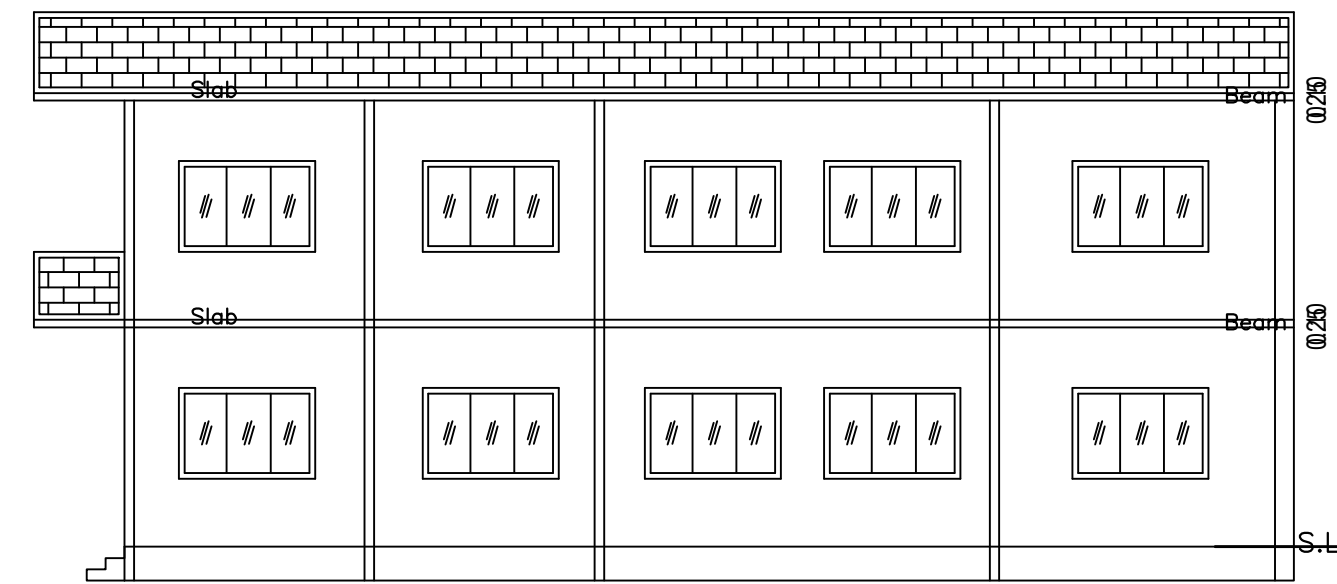
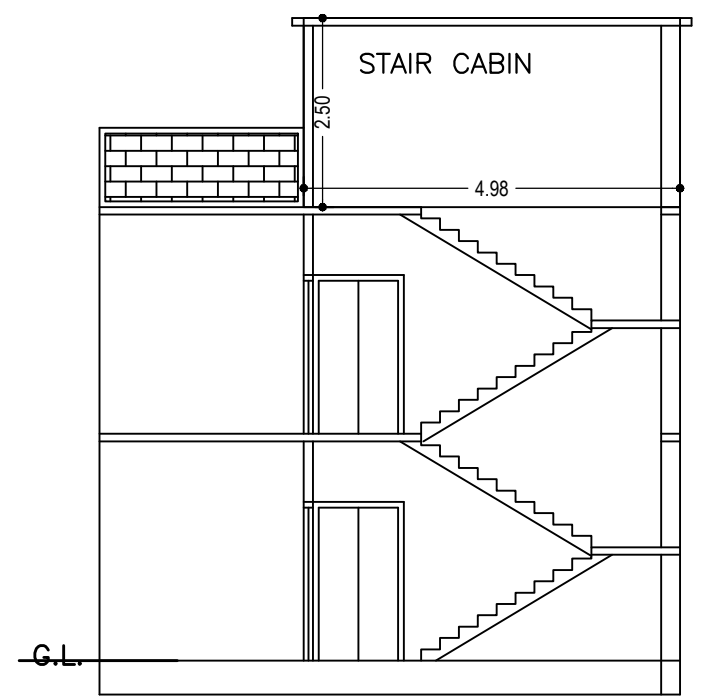
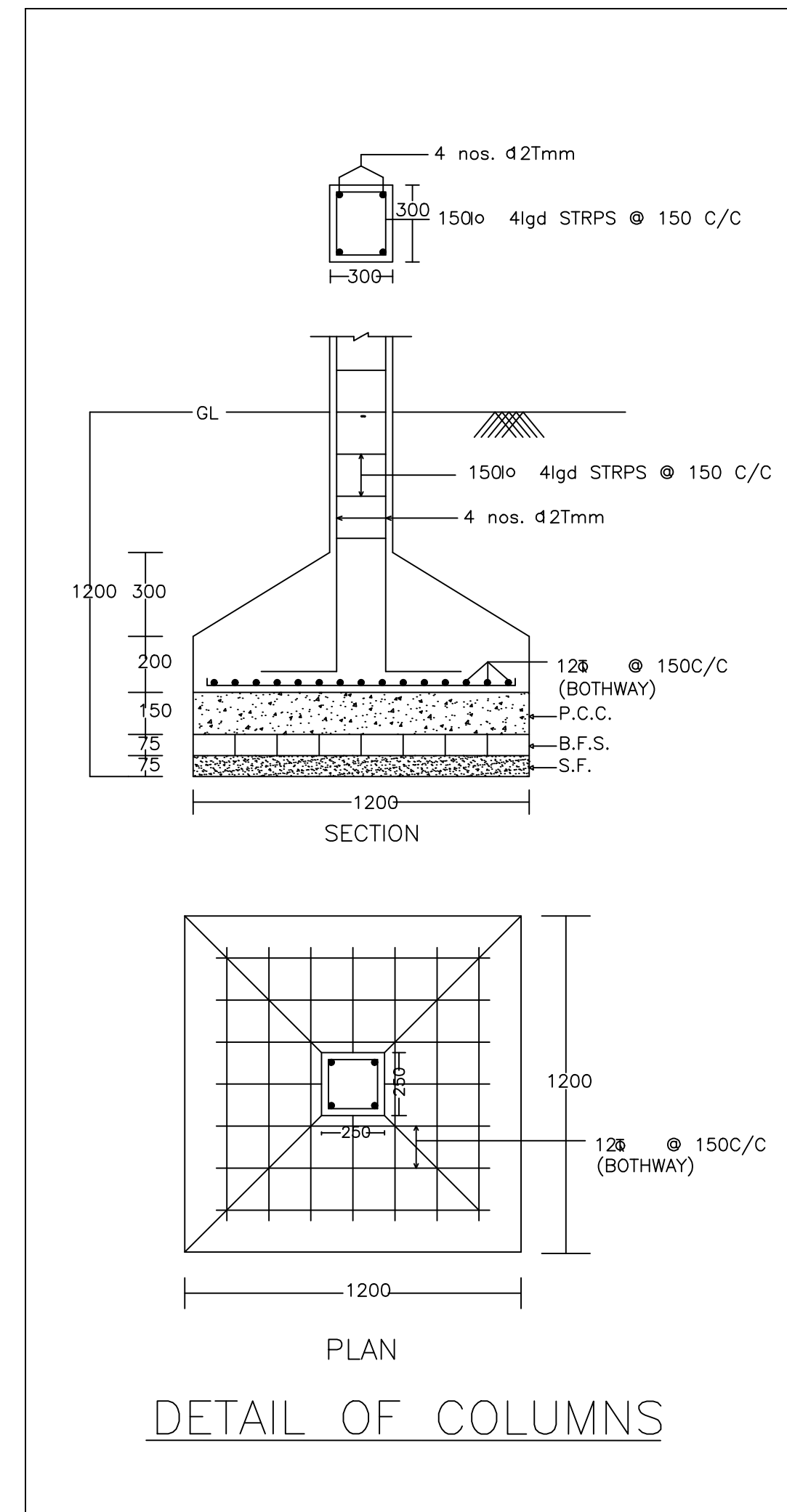
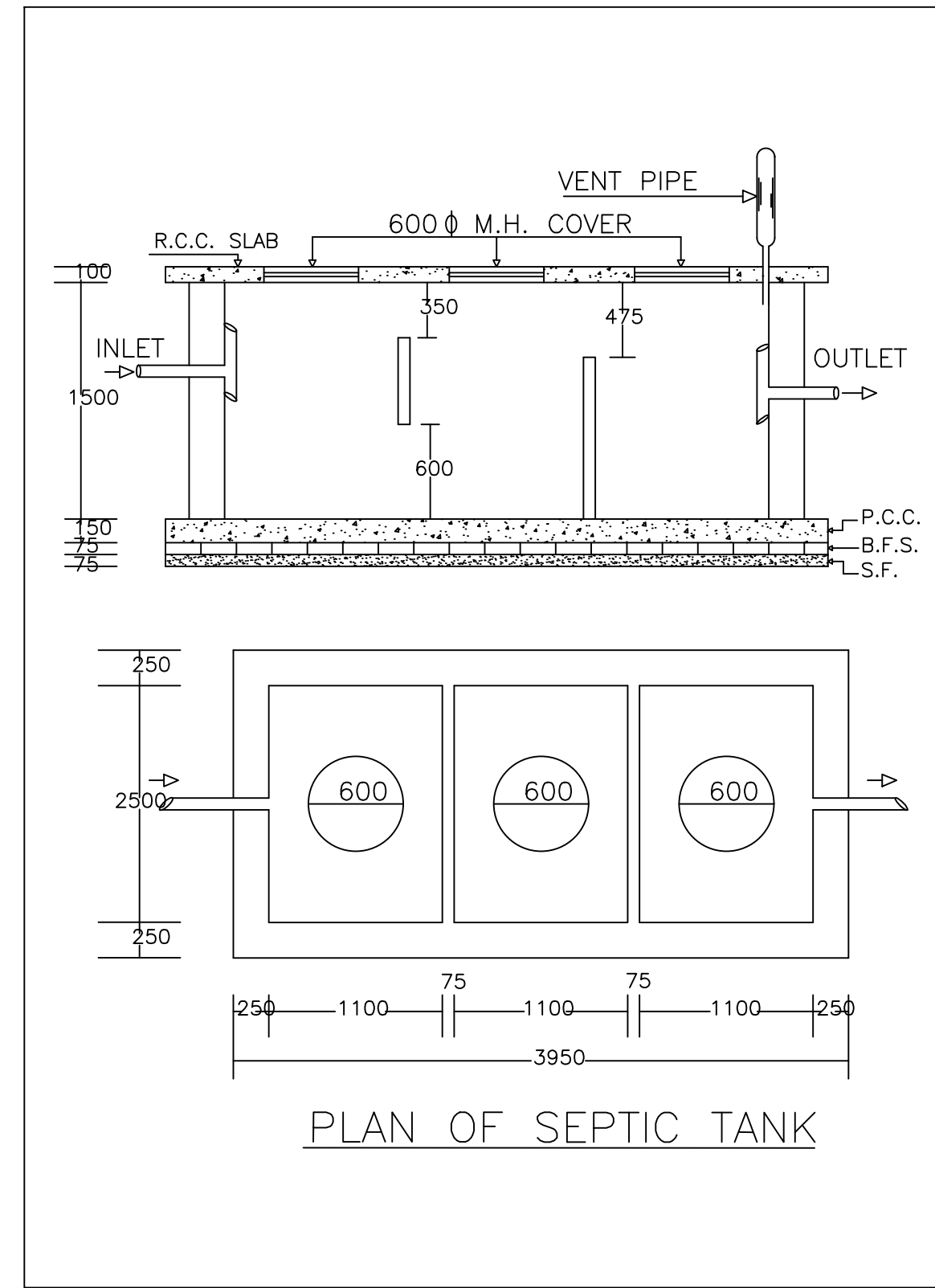
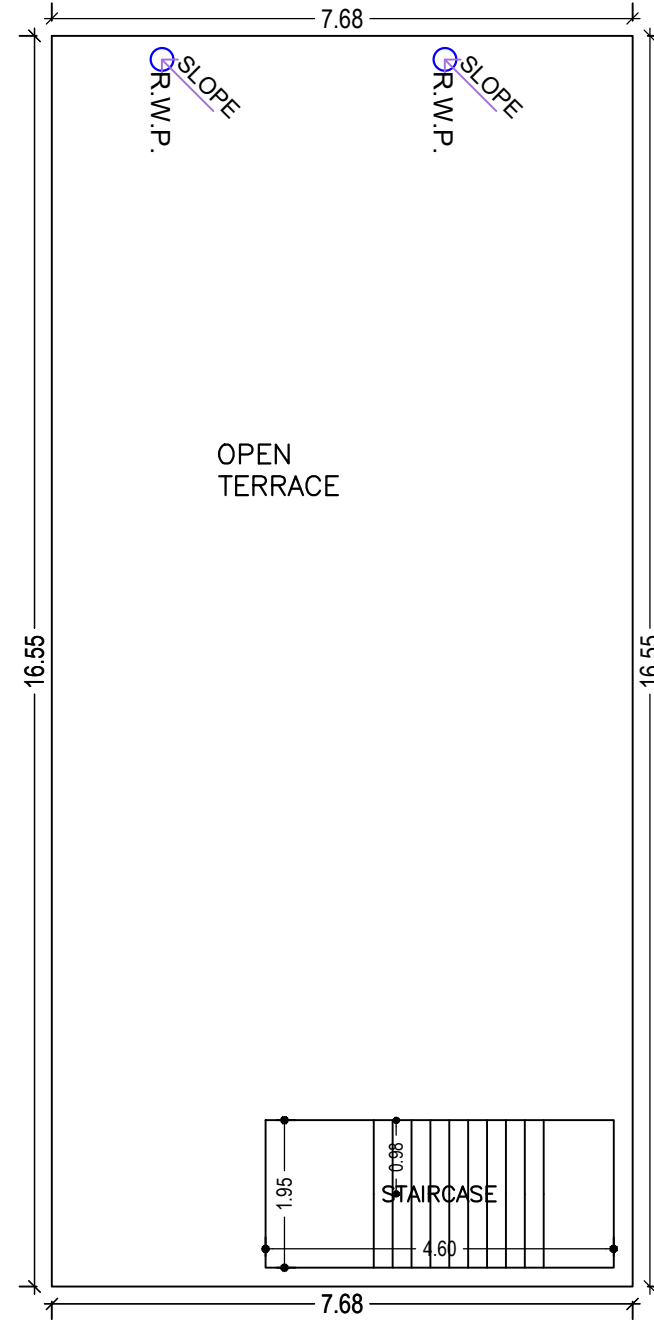
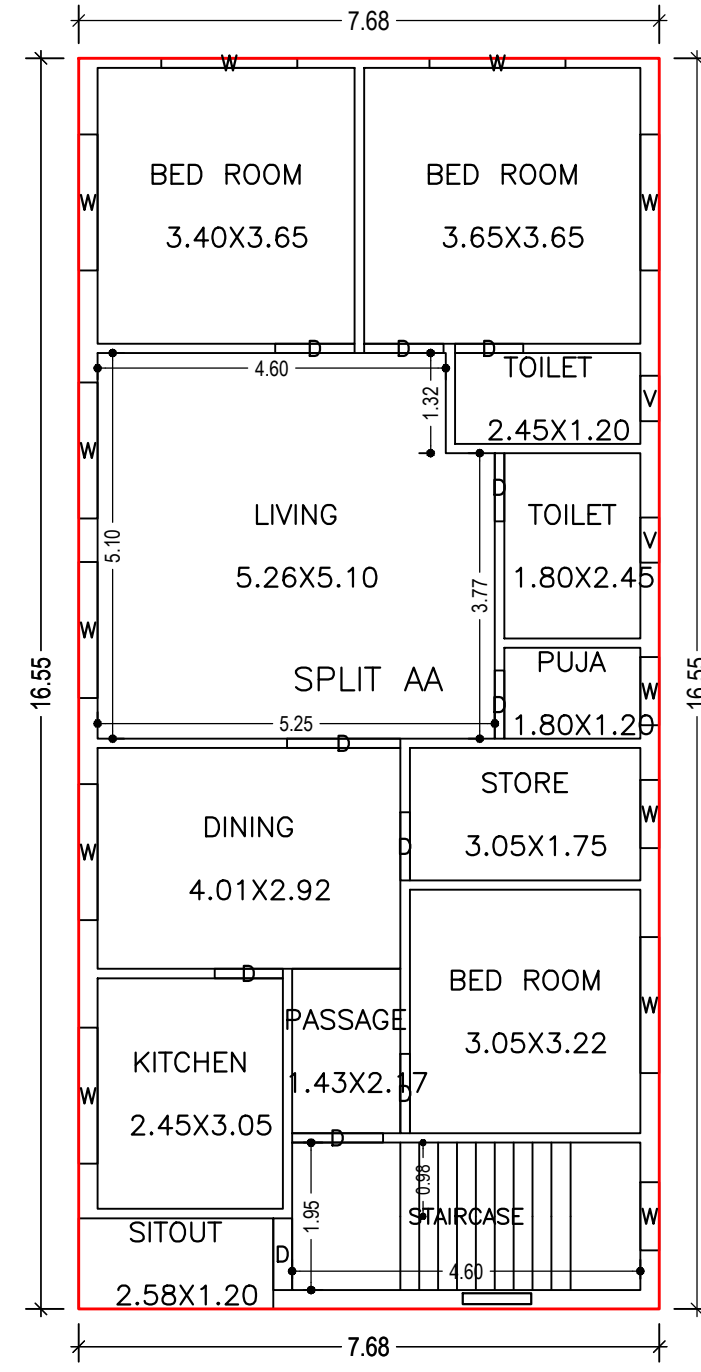
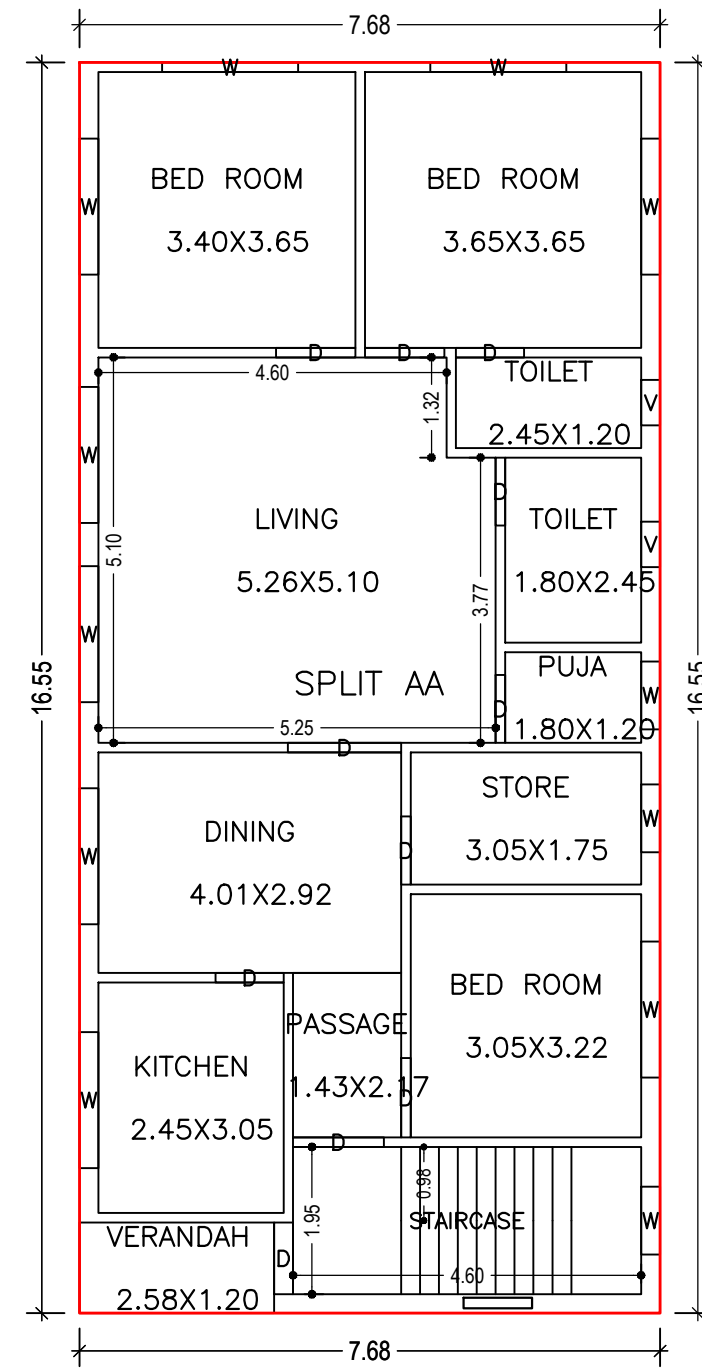

LTP NAME AND SIGNATURE	STRUCTURAL ENG'S NAME AND SIGNATURE	BUILDER NAME AND SIGNATURE	DIGITAL SIGNATURE
Partha Pal MADA/ENG/0002/2019			