

**SITE PLAN**  
SCALE - 1" = 16'-0"

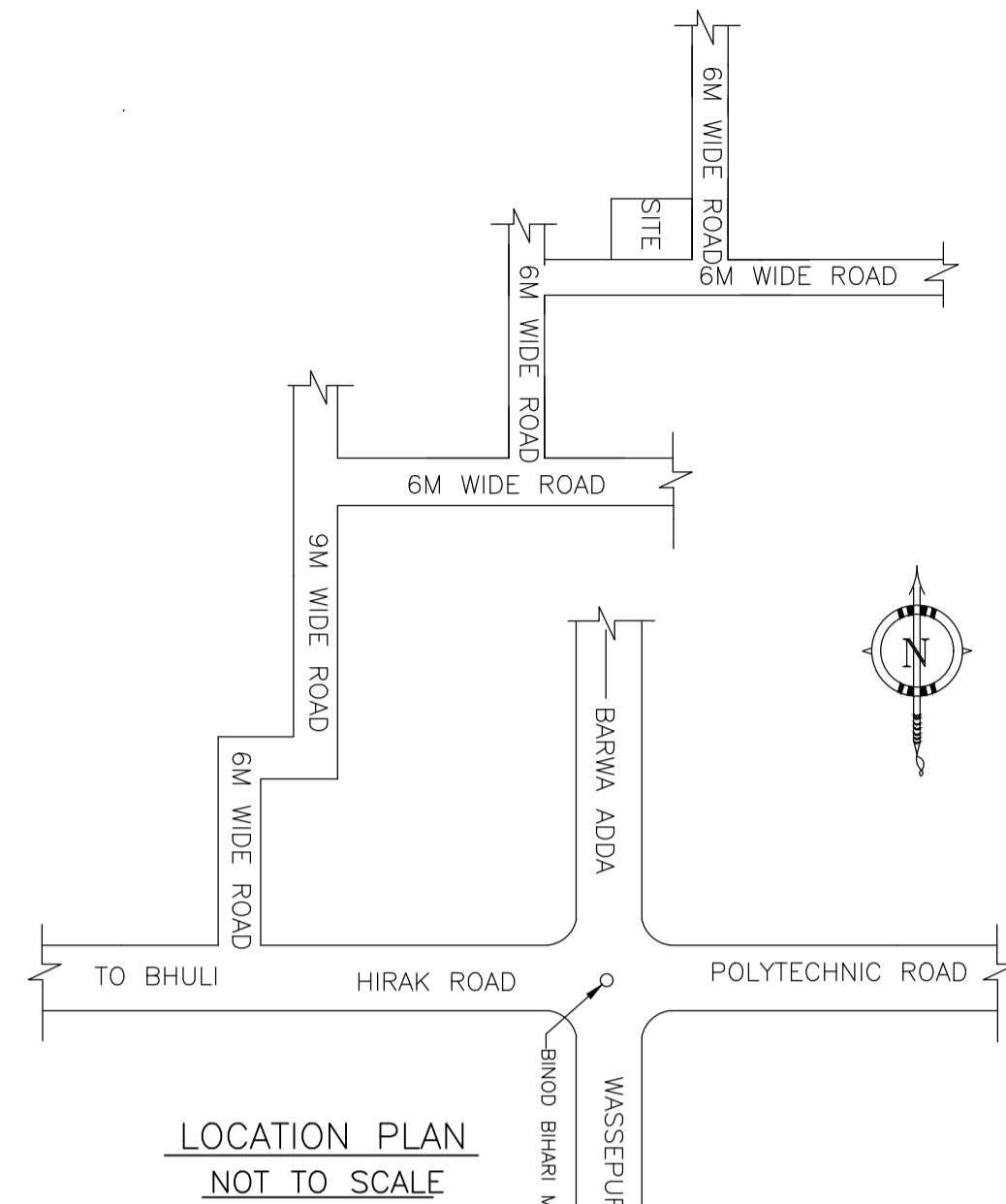

**LOCATION PLAN**  
NOT TO SCALE

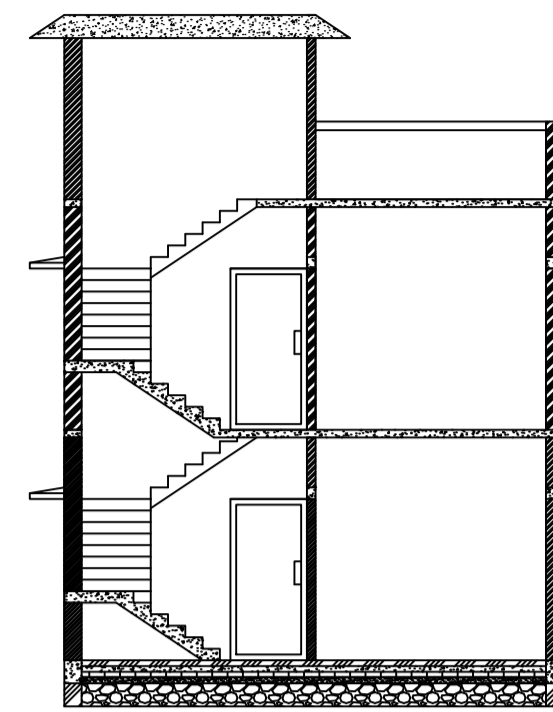

**SECTION X-X**  
SCALE - 1" = 8'-0"

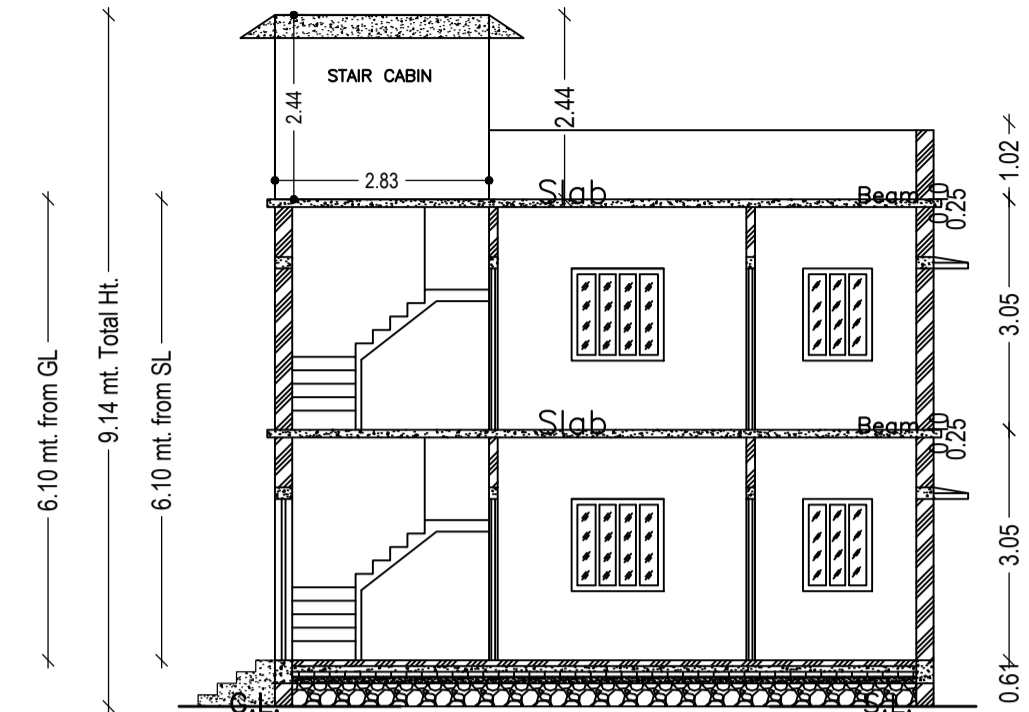

**SECTION Y-Y**  
SCALE - 1" = 8'-0"

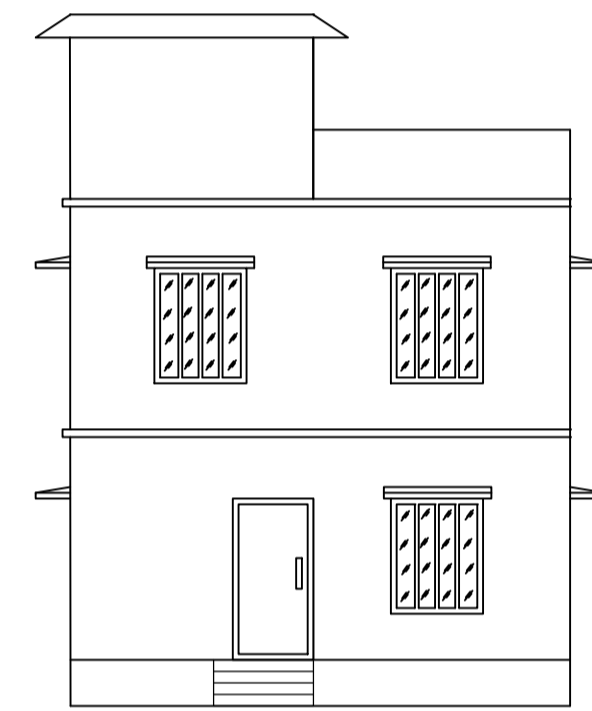

**FRONT ELEVATION**  
SCALE - 1" = 8'-0"

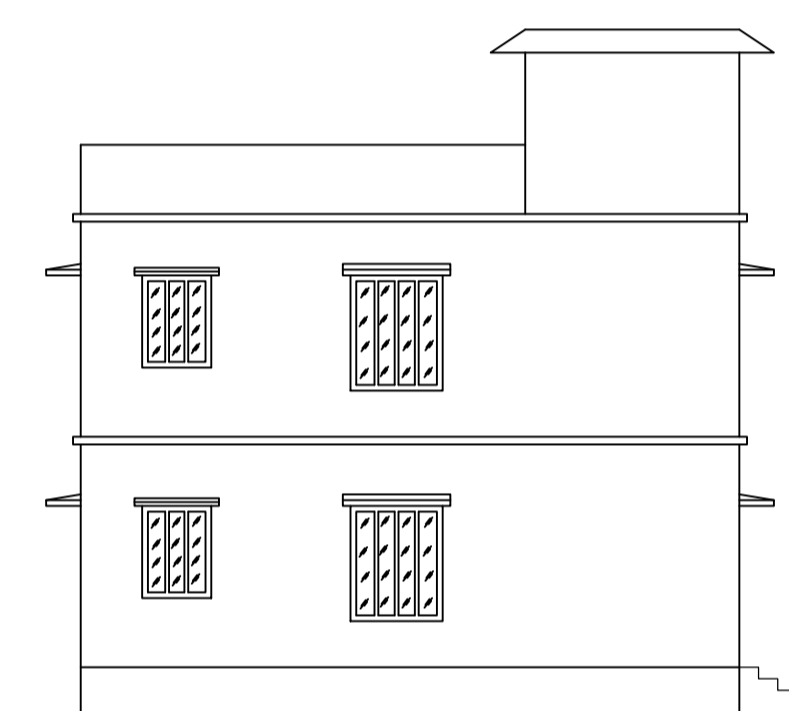

**LEFT SIDE ELEVATION**  
SCALE - 1" = 8'-0"

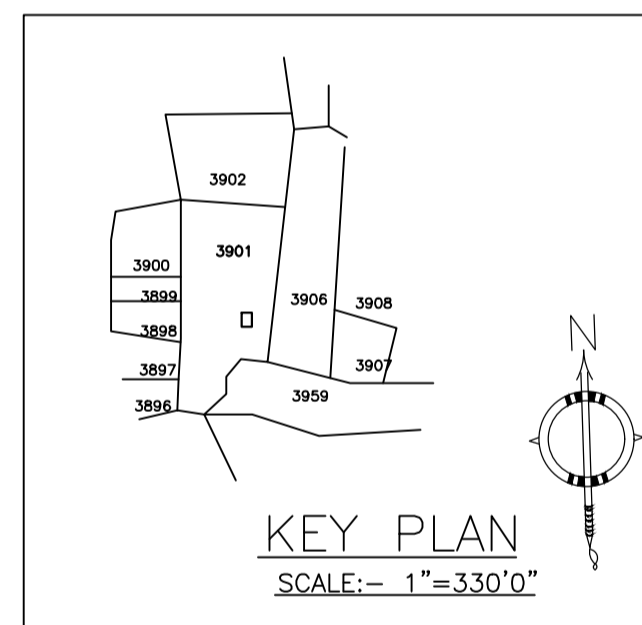

**KEY PLAN**  
SCALE:- 1"=330'0"

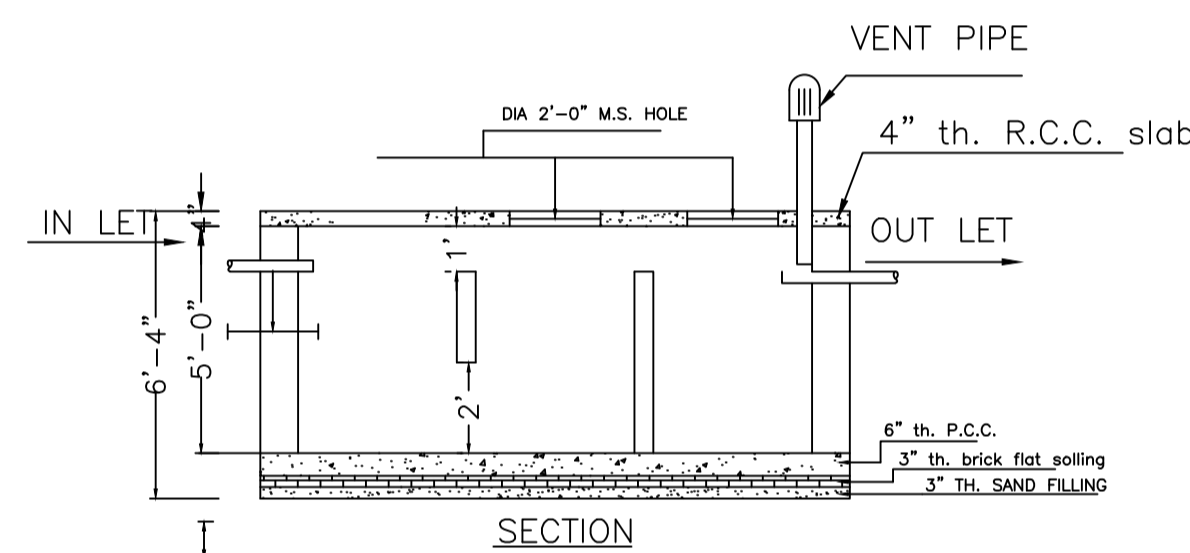

**SECTION**  
**DETAILS OF SEPTIC TANK**  
SCALE - 1" = 4'-0"

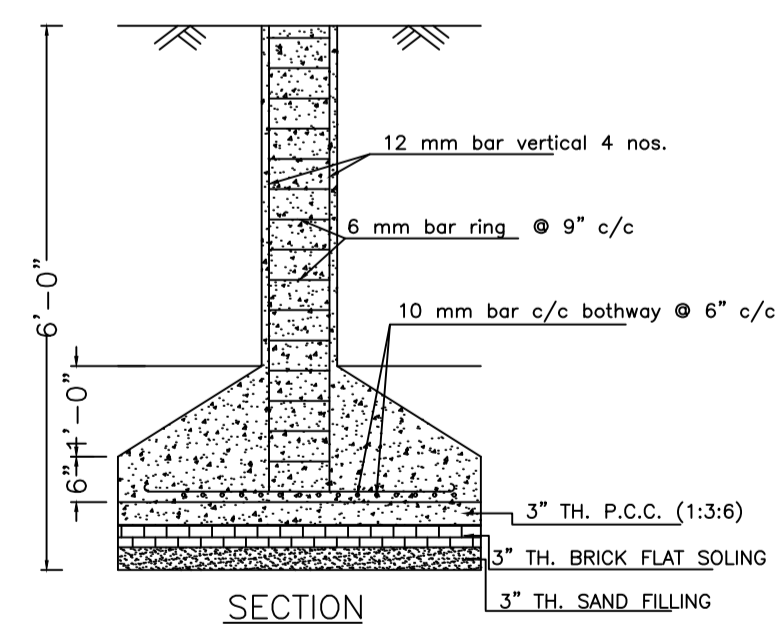

**SECTION**  
**DETAILS OF COLUMN FOUNDATION**  
SCALE - 1" = 2'-0"

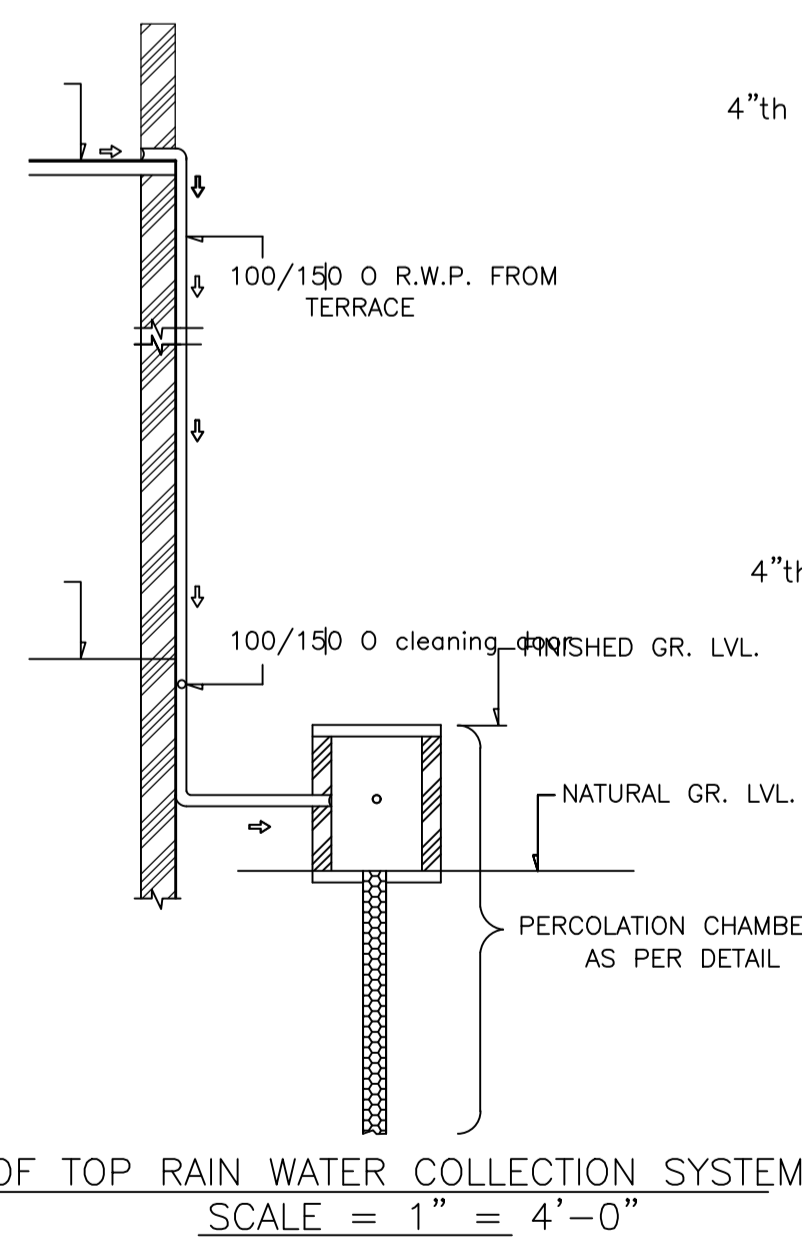

**ROOF TOP RAIN WATER COLLECTION SYSTEM**  
SCALE = 1" = 4'-0"

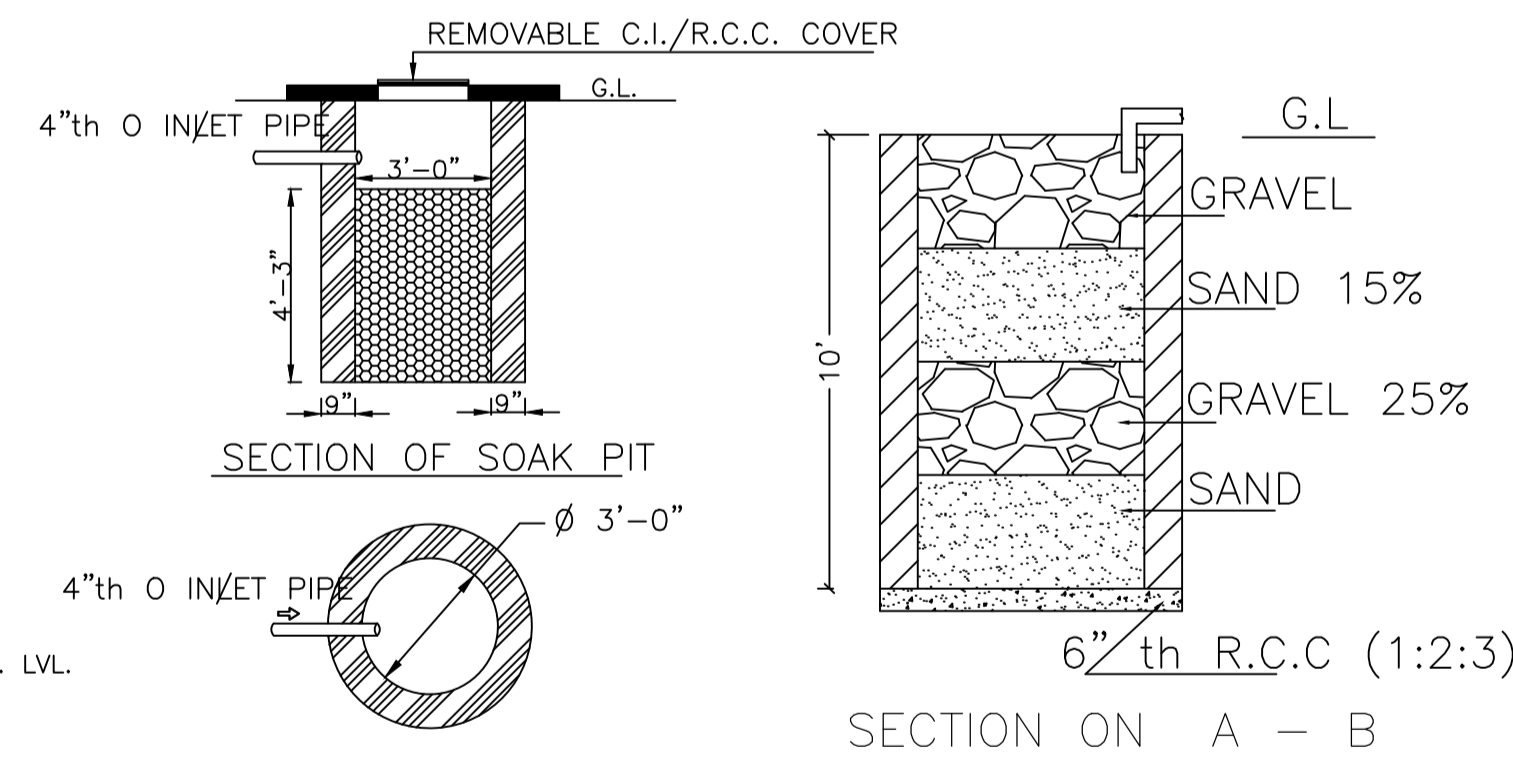

**SECTION OF SOAK PIT**  
**DETAILS OF SOAK PIT**  
SCALE = 1" = 2'-0"

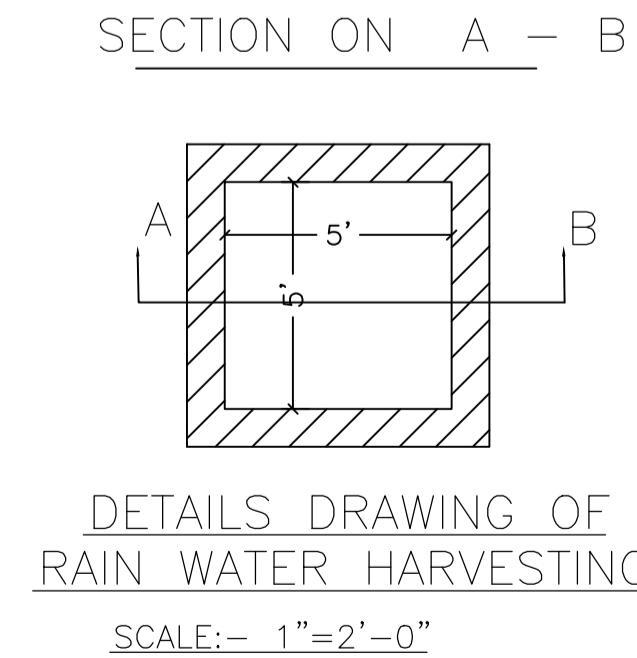

**DETAILS DRAWING OF RAIN WATER HARVESTING**  
SCALE:- 1"=2'-0"

**SCHEDULE OF DOOR:**

BUILDING NAME	NAME	LENGTH	HEIGHT	NOS
A (RAJWANTI)	D	0.76	2.10	02
A (RAJWANTI)	D	0.88	2.10	02
A (RAJWANTI)	D	0.91	2.10	04
A (RAJWANTI)	D	1.02	2.10	02

**SCHEDULE OF WINDOW/VENTILATION:**

BUILDING NAME	NAME	LENGTH	HEIGHT	NOS
A (RAJWANTI)	V	0.61	1.20	02
A (RAJWANTI)	W	0.91	1.20	04
A (RAJWANTI)	W	1.22	1.20	10

**Building :A (RAJWANTI)**

Floor Name	Total Built Up Area (Sq.mt.)	Proposed FAR Area (Sq.mt.) Res.	Total FAR Area (Sq.mt.)	Total Consumed Additional FAR Area (Sq.mt.)	Tnmt (No.)
Ground Floor	61.76	61.76	61.76	61.76	01
First Floor	61.76	61.76	61.76	61.76	00
Terrace Floor	0.00	0.00	0.00	0.00	00
Total:	123.52	123.52	123.52	123.52	01
Total Number of Same Buildings :	1				
Total :	123.52	123.52	123.52	123.52	01

**Proposal Basic Information**

Proposal File No.	MADA/BP/0222/2022
Owner Name	SMT. RAJWANTI DEVI
Khata No	OLD KHATA NO-25, NEW KHATA NO-35
Plot No	OLD PLOT NO-2537, NEW PLOT NO-3901
Village Name	Bara Pichri
Use	Residential
SubUse	Bungalow/ Dwelling / Non Apartment

AREA STATEMENT MINERAL AREA DEVELOPMENT AUTHORITY		VERSION NO.:	1.0.62
PROJECT DETAIL:		VERSION DATE:	16/10/2020
Region: JHARKHAND URBAN LOCAL BODIES	Plot Use: Residential		
District: DHANBAD	Plot SubUse: Bungalow/ Dwelling / Non Apartment		
Authority: MINERAL AREA DEVELOPMENT AUTHORITY	PlotNearbyReligiousStructure: NA		
Inward No: MADA/BP/0222/2022	Plot/SubPlot No: OLD PLOT NO-2537, NEW PLOT NO-3901		
Application Type: General Proposal	North: Plot No. - SAME PLOT		
Project Type: Building Permission	South: Road Width - 6.10		
Nature of Development: New	East: Road Width - 6.10		
Location of Development Area: Old Area	West: Plot No. - SAME PLOT		
<b>AREA DETAILS:</b>			<b>SQ.MT.</b>
AREA OF PLOT (Minimum)	(A)		111.39
NET AREA OF PLOT(Gross Plot Area - Deduction from Gross Plot area)	(A-Deductions)		111.39
Deduction for Balance Plot Area(from Gross Plot Area)			
Common Plot			12.08
Total			12.08
BALANCE AREA OF PLOT (Net Plot Area - Recreational/Amenity space)	(A-Deductions)		99.30
PLOT AREA FOR COVERAGE(Net Plot Area)	(A-Deductions)		111.39
Plot Area for FAR (Net Plot Area + RoadWidening Area)	(A-Deductions)		111.39
<b>COVERAGE CHECK</b>			
Permissible Coverage area ( 70.00 % )			77.97
Proposed Coverage Area ( 55.45 % )			61.76
Total Prop. Coverage Area ( 55.45 % )			61.76
Balance coverage area ( 14.55 % )			16.21
<b>FAR CHECK</b>			
Perm. FAR Area ( 2.50 )			278.48
Total Perm. FAR area			278.48
Residential FAR			123.52
Proposed FAR Area			123.52
Total Proposed FAR Area			123.52
Consumed FAR (Factor)			1.11
Balance FAR Area			154.96
<b>BUILT UP AREA CHECK</b>			
Total Proposed BuiltUp Area			123.52
ARCHITECT (Regd)			RAM PRATAP SINGH
ENGINEER (Regd)			
SUPERVISOR (Regd)			
OWNER (Regd)			SMT. RAJWANTI DEVI
DEVELOPMENT AUTHORITY			LOCAL BODY

COLOR INDEX	
PLOT BOUNDARY	[Red Line]
ABUTTING ROAD	[Green Line]
PROPOSED CONSTRUCTION	[Yellow Line]
COMMON PLOT	[Blue Line]
ROAD WIDENING AREA	[Orange Line]
EXISTING (To be retained)	[Light Blue Line]
EXISTING (To be demolished)	[Dark Blue Line]

**Buildingwise Floor FAR Details**

Floor Name	Building Name A (RAJWANTI)		Total	
	Proposed Built Up Area (Sq.mt.)	Proposed FAR Area (Sq.mt.)	Total Proposed Built Up Area (Sq.mt.)	Total FAR Area (Sq.mt.)
Ground Floor	61.76	61.76	61.76	61.76
First Floor	61.76	61.76	61.76	61.76
Terrace Floor	0.00	0.00	0.00	0.00
Total :	123.52	123.52	123.52	123.52

**Building USE/SUBUSE Details**

Building Name	Building Use	Building SubUse	Building Structure
A (RAJWANTI)	Residential	Bungalow/ Dwelling / Non Apartment	Non-Highrise

**UnitBUA Table for Building :A (RAJWANTI)**

FLOOR	Name	UnitBUA Type	UnitBUA Area	Carpet Area	No. of Rooms	No. of Tenement
GROUND FLOOR PLAN	SPLIT 1	FLAT	123.52	121.65	5	1
FIRST FLOOR PLAN	SPLIT 1	FLAT	0.00	0.00	5	0
Total:	-	-	123.52	121.65	10	1

**FAR & Tenement Details (Table 4c-1)**

Building	No. of Same Bldg	Total Built Up Area (Sq.mt.)	Proposed FAR Area (Sq.mt.) Res.	Total FAR Area (Sq.mt.)	Total Consumed Additional FAR Area (Sq.mt.)	Tnmt (No.)
A (RAJWANTI)	1	123.52	123.52	123.52	123.52	01
Grand Total :	1	123.52	123.52	123.52	123.52	01

LTP NAME AND SIGNATURE	STRUCTURAL ENG'S NAME AND SIGNATURE	BUILDER NAME AND SIGNATURE	DIGITAL SIGNATURE
RAM PRATAP SINGH MADA/ARC/0024/2019			

Proposal Basic Information	
Proposal File No.	MADA/BP/0222/2022
Owner Name	SMT. RAJWANTI DEVI
Khata No	OLD KHATA NO- 25, NEW KHATA NO-35
Plot No	OLD PLOT NO- 2537, NEW PLOT NO-3901
Village Name	Bara Pichri
Use	Residential
SubUse	Bungalow/ Dwelling / Non Apartment

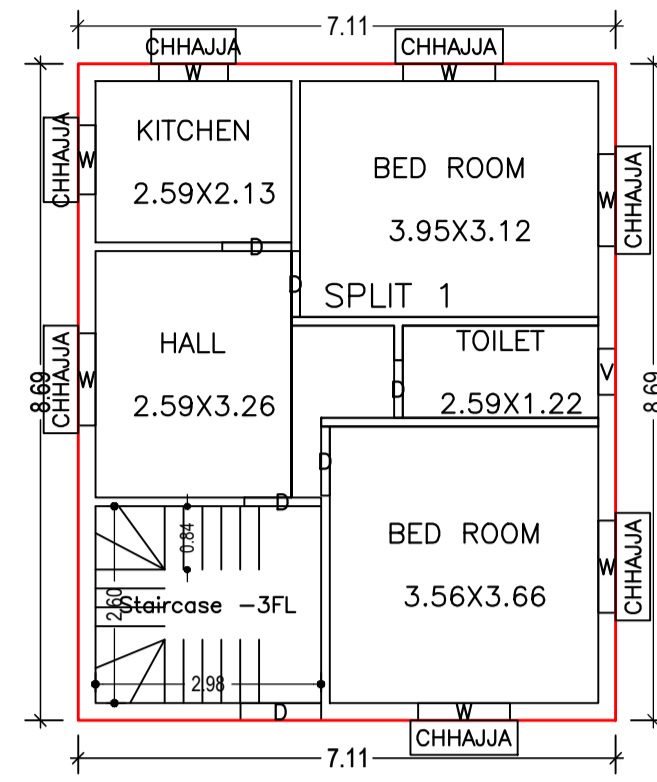

GROUND FLOOR PLAN  
(Proposed)  
SCALE 1:100

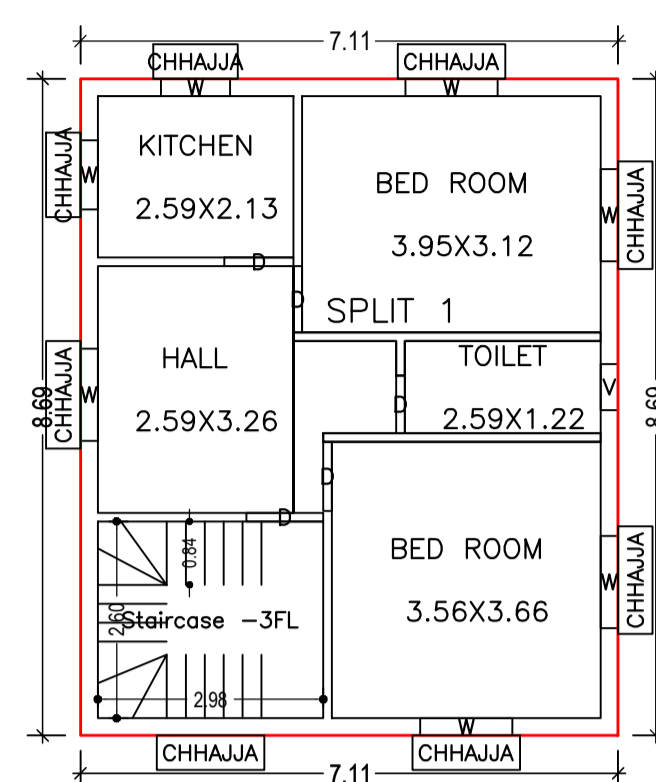

FIRST FLOOR PLAN  
(Proposed)  
SCALE 1:100

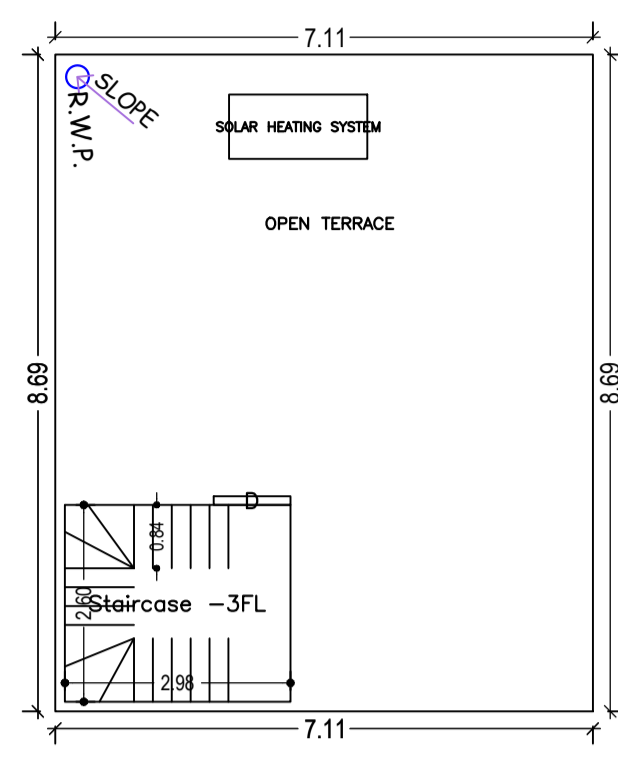

TERRACE FLOOR PLAN  
SCALE 1:100

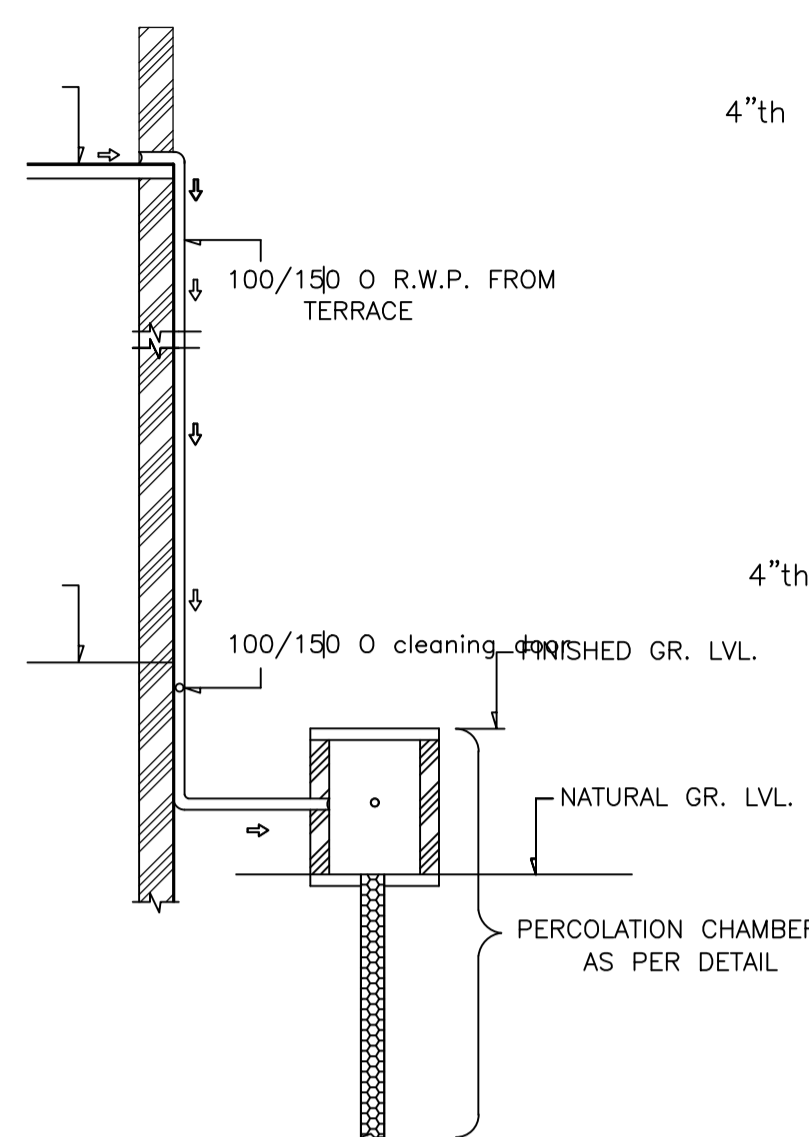

ROOF TOP RAIN WATER COLLECTION SYSTEM  
SCALE = 1" = 4'-0"

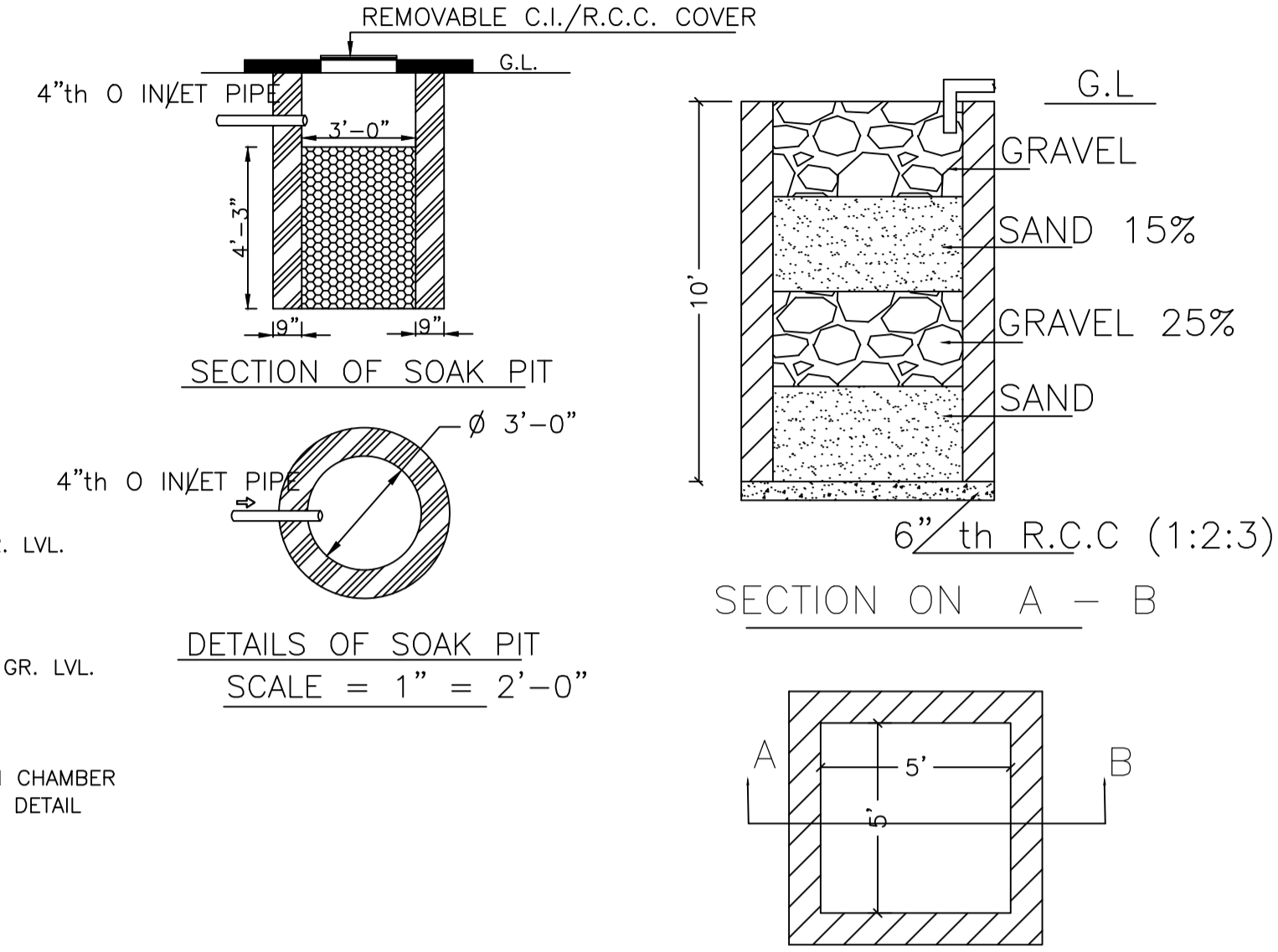

DETAILS DRAWING OF  
RAIN WATER HARVESTING  
SCALE:- 1"=2'-0"

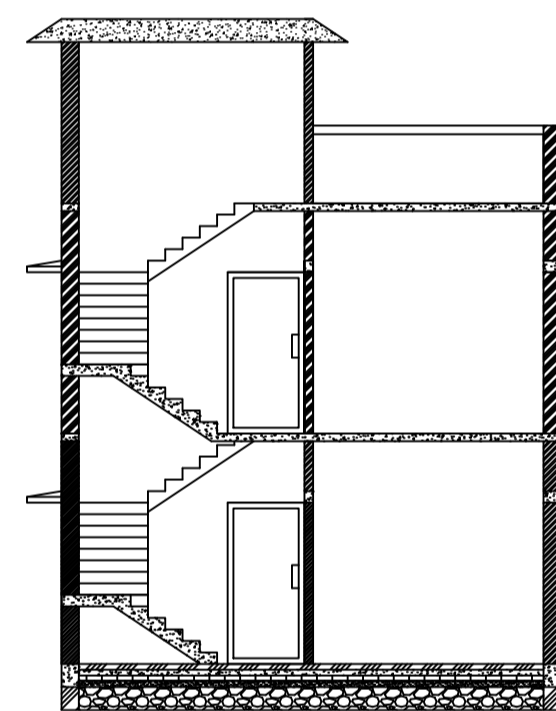

SECTION X-X  
SCALE - 1" = 8'-0"

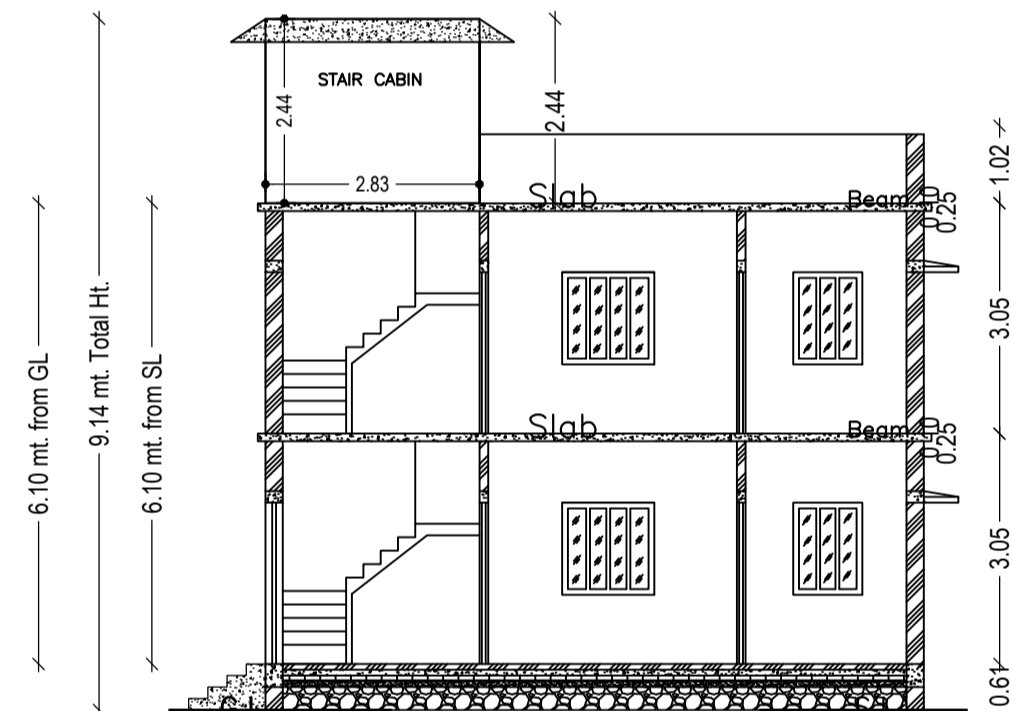

SECTION Y-Y  
SCALE - 1" = 8'-0"

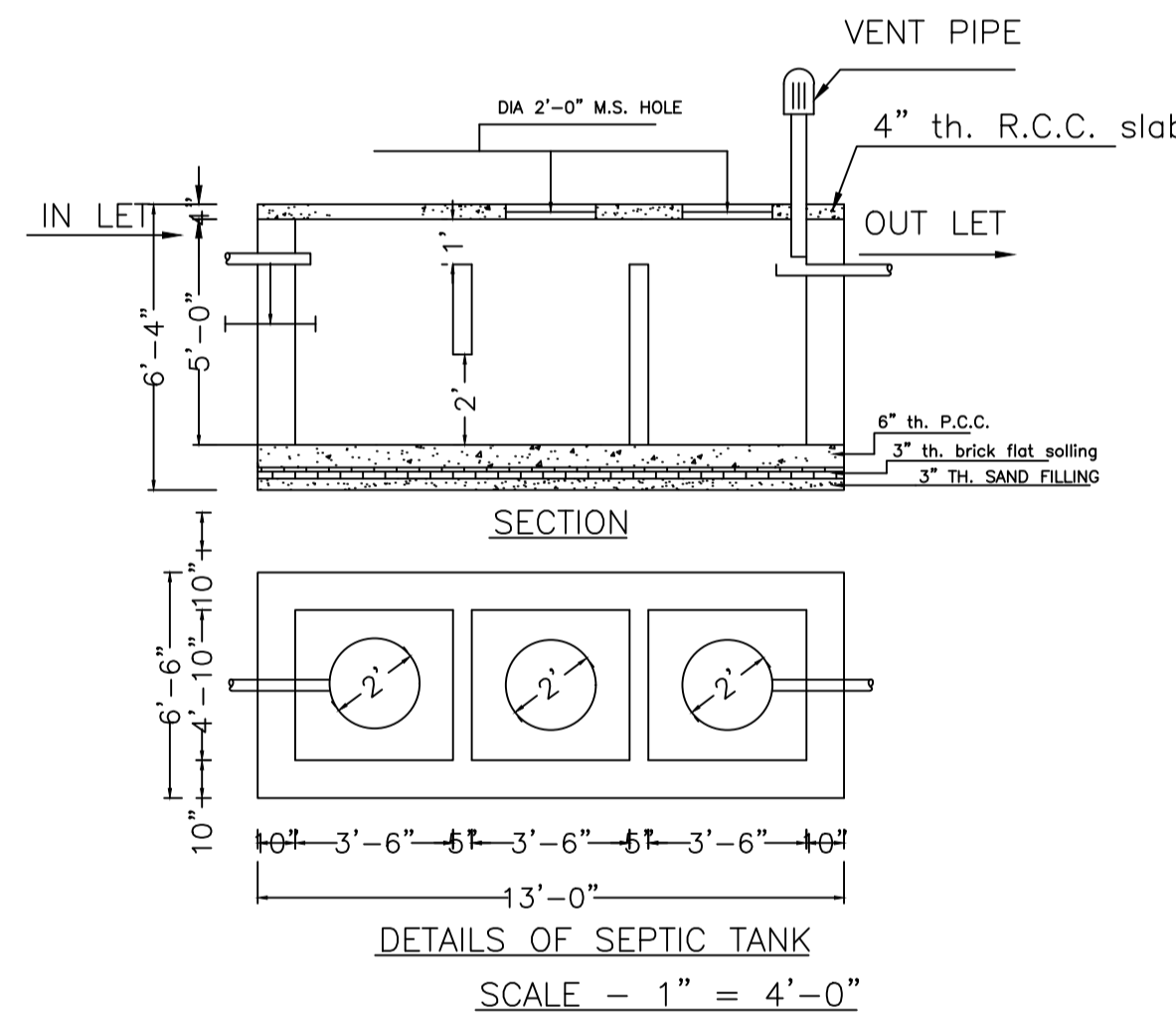

DETAILS OF SEPTIC TANK  
SCALE - 1" = 4'-0"

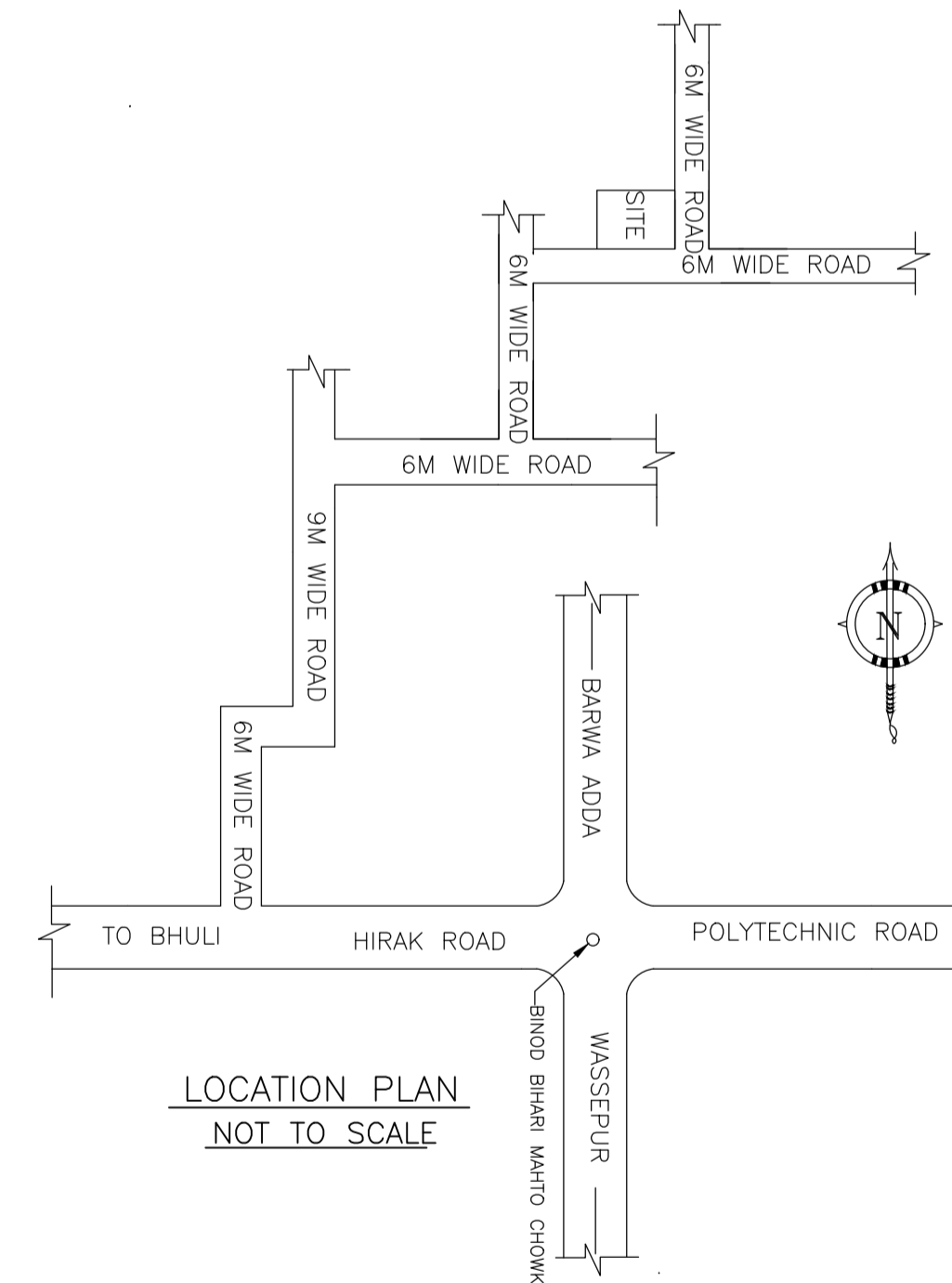

LOCATION PLAN  
NOT TO SCALE

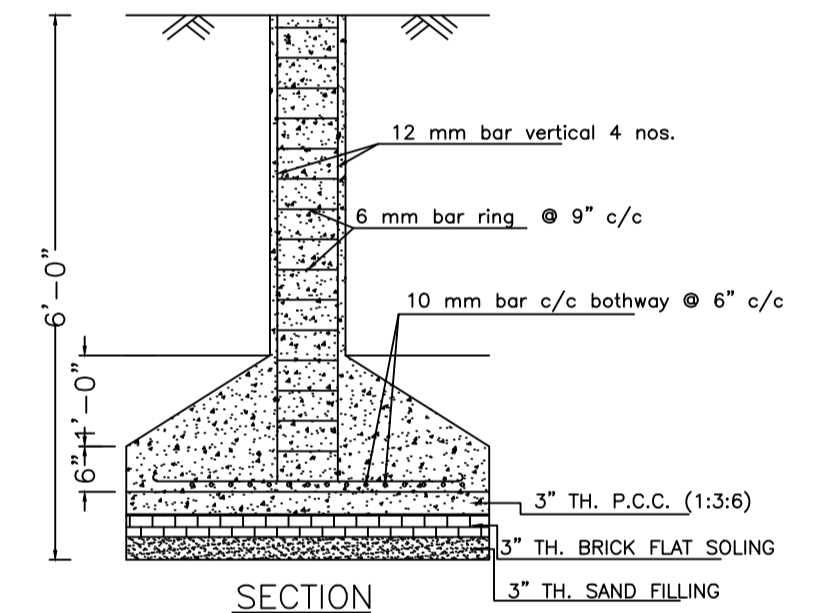

SECTION

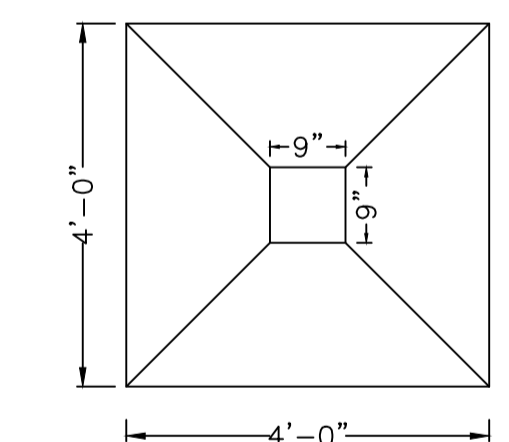

PLAN

DETAILS OF COLUMN FOUNDATION  
SCALE - 1" = 2'-0"

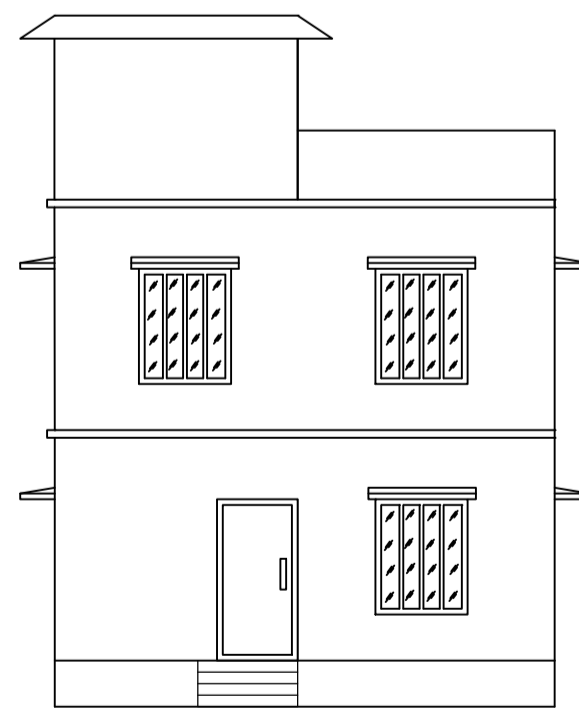

FRONT ELEVATION  
SCALE - 1" = 8'-0"

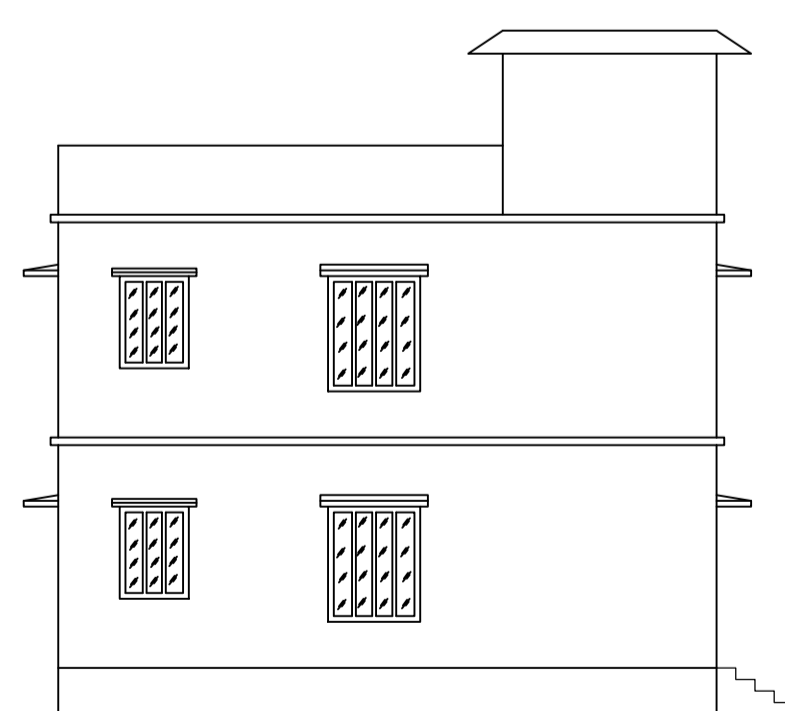

LEFT SIDE ELEVATION  
SCALE - 1" = 8'-0"

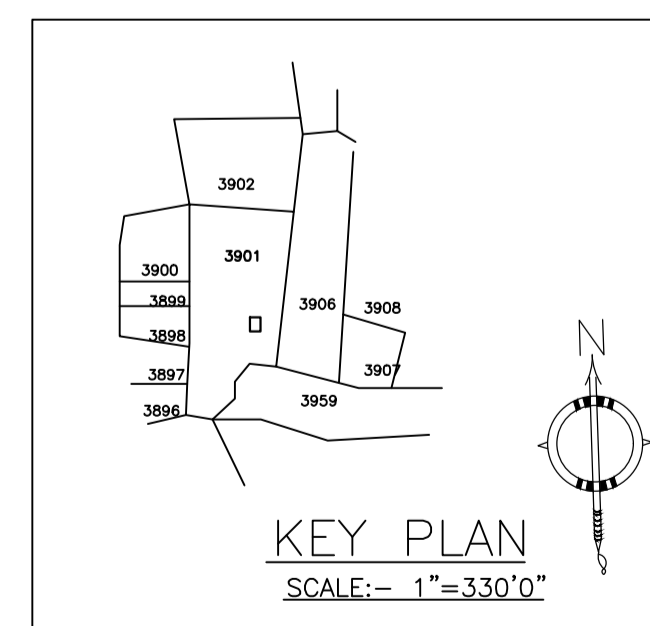

KEY PLAN  
SCALE:- 1"=330'0"

LTP NAME AND SIGNATURE	STRUCTURAL ENG'S NAME AND SIGNATURE	BUILDER NAME AND SIGNATURE	DIGITAL SIGNATURE
RAM PRATAP SINGH MADA/ARC/0024/2019			