

NOTES

1. ALL DIMENSIONS ARE IN METERS UNLESS OTHERWISE SPECIFIED.
2. THE PROPOSED BUILDING SHALL BE CONSTRUCTED AS PER THE ARCHITECTURAL DRAWINGS.
3. THE PROPOSED BUILDING SHALL BE CONSTRUCTED AS PER THE ELECTRICAL DRAWINGS.
4. THE PROPOSED BUILDING SHALL BE CONSTRUCTED AS PER THE MECHANICAL DRAWINGS.
5. THE PROPOSED BUILDING SHALL BE CONSTRUCTED AS PER THE SANITARY DRAWINGS.
6. THE PROPOSED BUILDING SHALL BE CONSTRUCTED AS PER THE STRUCTURAL DRAWINGS.
7. THE PROPOSED BUILDING SHALL BE CONSTRUCTED AS PER THE WATER SUPPLY DRAWINGS.
8. THE PROPOSED BUILDING SHALL BE CONSTRUCTED AS PER THE SEWERAGE DRAWINGS.
9. THE PROPOSED BUILDING SHALL BE CONSTRUCTED AS PER THE RAIN WATER HARVESTING DRAWINGS.
10. THE PROPOSED BUILDING SHALL BE CONSTRUCTED AS PER THE LANDSCAPE ARCHITECTURE DRAWINGS.

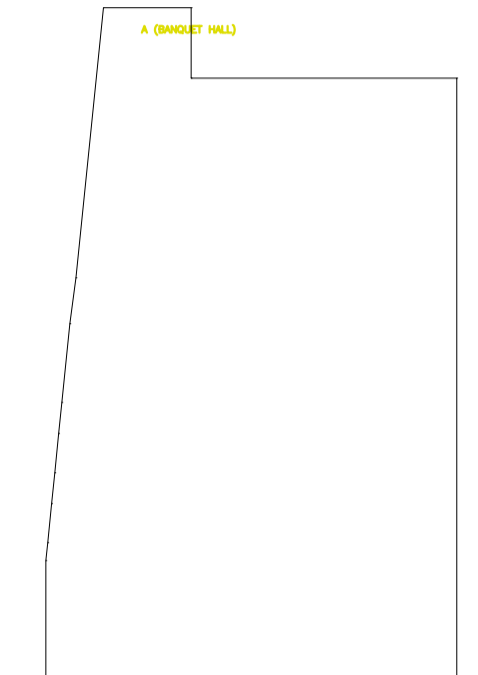

LEGEND

Symbol	Description
—	Proposed Building Footprint
—	Proposed Road Widening
—	Proposed Terrace
—	Proposed Road
—	Proposed Road Widening
—	Proposed Road
—	Proposed Road Widening
—	Proposed Road

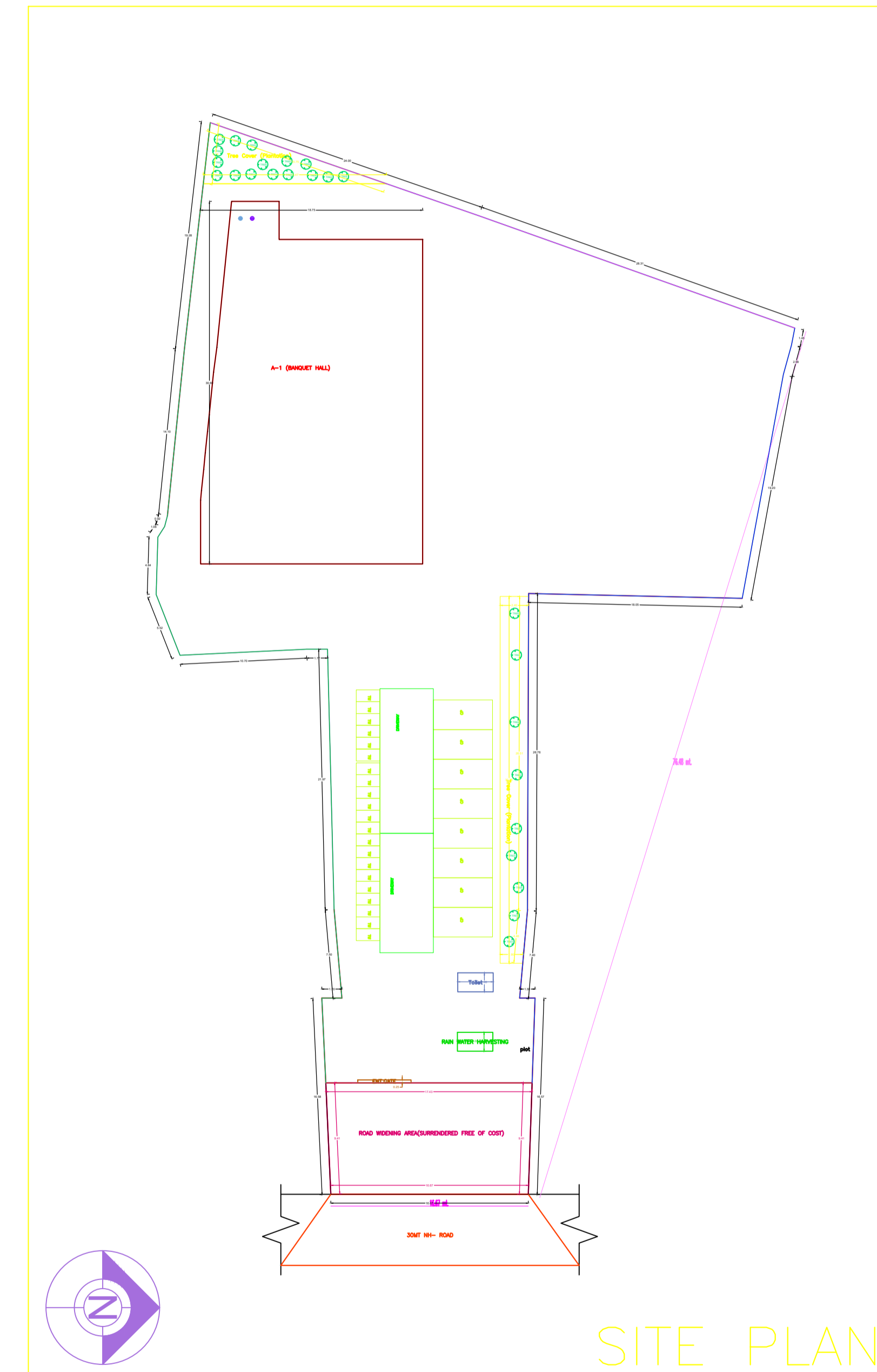
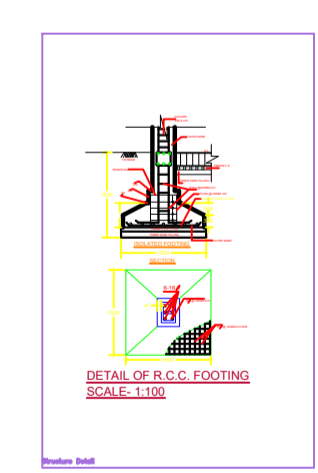
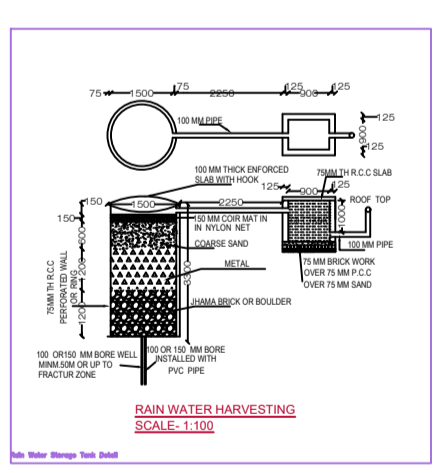
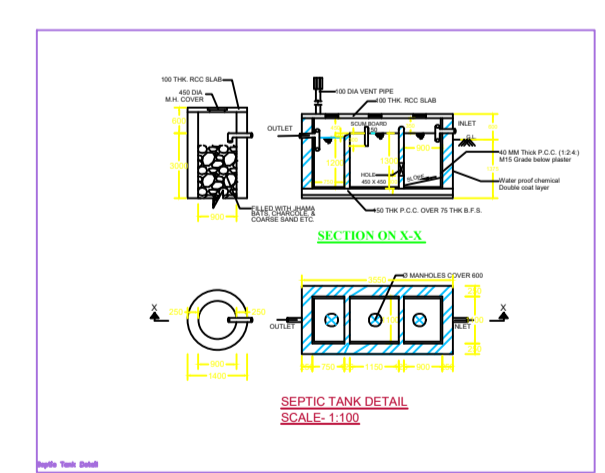
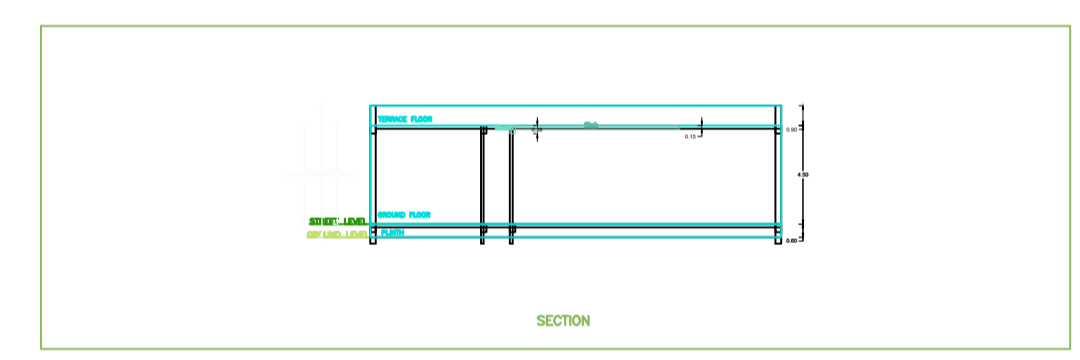
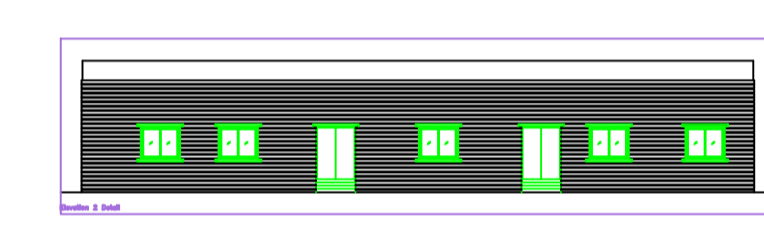
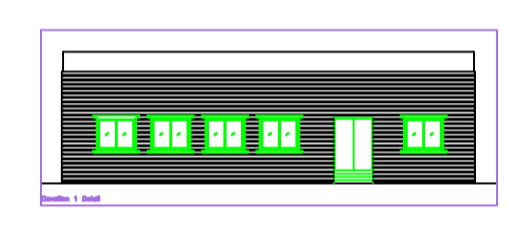

SITE PLAN