

Project Title - SRI LAXMI NARAYAN SINGH

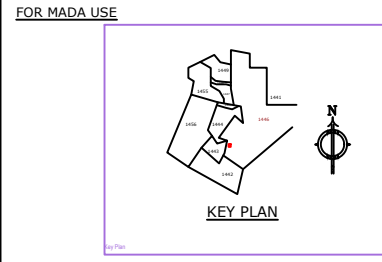
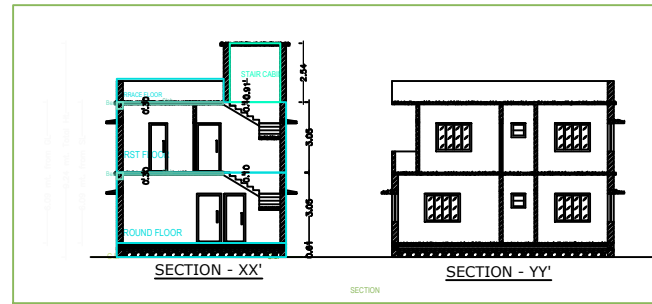

**FOR MADA USE**

PROPOSED PLAN FOR, SRI LAXMI NARAYAN SINGH S/O SHIV SINGH, AT PRESENT RESIDING AT, TETULMARI TOWNSHIP BL-23 QTR. NO-264, PO. & PS. TETULMARI, DIST. DHANBAD JHARKHAND, FOR RESIDENTIAL BUILDING AT, OLD KHATA NO- 10, NEW KHATA NO-133, OLD C.S.PLOT NO- 502, NEW C.S. PLOT NO-1446, AREA-2.96 DECIMAL SITUATED AT MAUZA NO:129, MAUZA -JALGORA, (GOVINDPUR), DISTRICT- DHANBAD (JHARKHAND)

**BRIEF SPECIFICATION**

FOUNDATION-----CEMENT CONCRETE (1:1:3:6)  
FOOTING-----R.C.C. (1:1:4:3)  
BRICK WORK IN FOUNDATION & SUPERSTRUCTURE  
FIRST CLASS BRICK WORK IN CEMENT MORTAR (1:6)  
D.P.C.-----1" D.P.C. IN CEMENT CONCRETE (1:2:4)  
COLUMNS-----R.C.C.  
BEAMS-----R.C.C.  
ROOF-----4"THK. R.C.C. ROOF  
LINTEL-----6"THK. R.C.C. LINTEL  
STAIRS-----RISE-- 6", TREAD-- 10"  
DOORS-----D-3'3"x7'0", D1-3'0"x7'0", D2-2'6"x7'0"  
WINDOWS-----W-5'0"x4'0", W1-4'0"x4'0", W2-2'6"x4'0"  
VENTS-----V-2'0"x2'0"

**SCHEDULE**

D- 3'-6" X 7'-0"	W- 5'-0" X 4'-0"
D1-3'-0" X 7'-0"	W1- 4'0" X 4'-0"
D2-2'-6" X 7'-0"	W1- 4'0" X 4'-0"
	V - 2'-0" X 2'-0"

**DETAILS OF AREA**

LAND AREA	: 1290 Sft.
GROUND FLOOR AREA	: 781.50 Sft.
FIRST FLOOR AREA	: 781.50 Sft.
COVERED AREA	: 1563.00 Sft.
% OF PLINTH AREA	: 60.58%
F.A.R	: 1.21

SIGN. OF OWNER  
SIGN. OF ARCHITECT

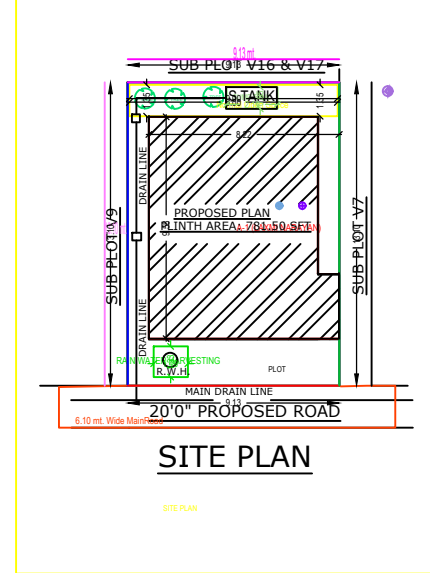
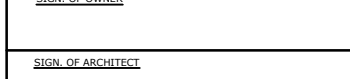
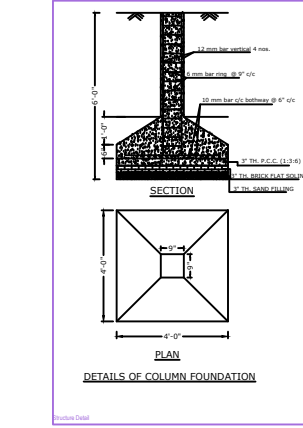
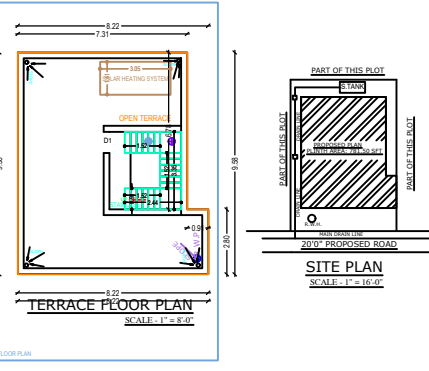
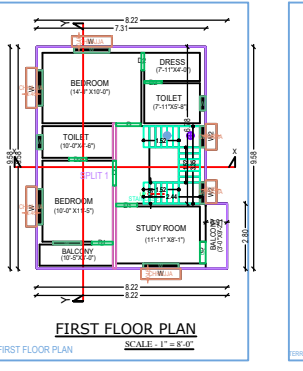
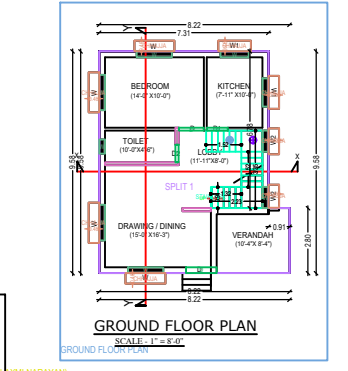
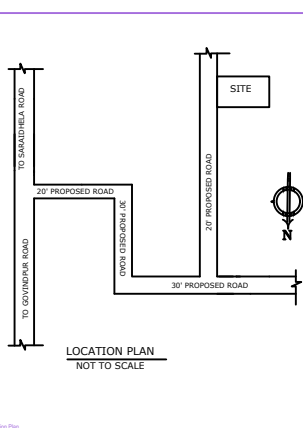
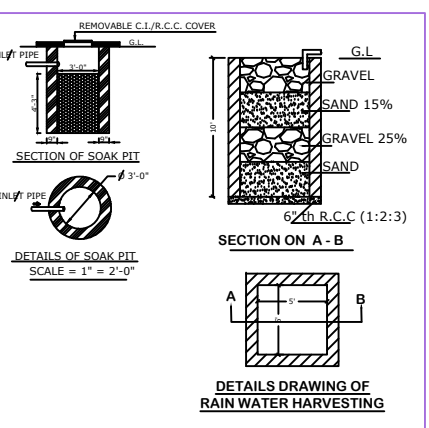
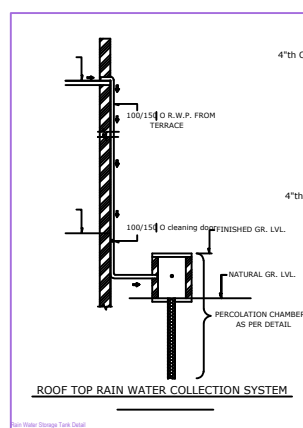
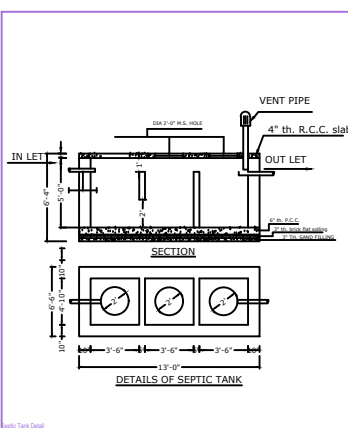

**AREA STATEMENT: MINIMAL AREA DEVELOPMENT**

PROJECT DETAILS	VERSION NO. 1.0.02
PROJECT NO.	18/10/2024
PROJECT NAME	PROPOSED MINIMAL AREA DEVELOPMENT
PROJECT TYPE	PROPOSED MINIMAL AREA DEVELOPMENT
PROJECT LOCATION	PROPOSED MINIMAL AREA DEVELOPMENT
PROJECT AREA	PROPOSED MINIMAL AREA DEVELOPMENT
PROJECT DATE	PROPOSED MINIMAL AREA DEVELOPMENT
PROJECT STATUS	PROPOSED MINIMAL AREA DEVELOPMENT
PROJECT OWNER	PROPOSED MINIMAL AREA DEVELOPMENT
PROJECT ARCHITECT	PROPOSED MINIMAL AREA DEVELOPMENT
PROJECT ENGINEER	PROPOSED MINIMAL AREA DEVELOPMENT
PROJECT SURVEYOR	PROPOSED MINIMAL AREA DEVELOPMENT
PROJECT CONSULTANT	PROPOSED MINIMAL AREA DEVELOPMENT
PROJECT REVIEWER	PROPOSED MINIMAL AREA DEVELOPMENT
PROJECT APPROVER	PROPOSED MINIMAL AREA DEVELOPMENT
PROJECT SIGNATURE	PROPOSED MINIMAL AREA DEVELOPMENT
PROJECT DATE	PROPOSED MINIMAL AREA DEVELOPMENT

**COLOR INDEX**

PROPOSED WORK (COVERAGE AREA)	Green
EXISTING (To be retained)	Yellow
EXISTING (To be demolished)	Red

**MARGIN DETAIL**

Margin Type	Front Margin	Rear Margin	Side Margin	Side2 Margin
MIN. CLEARANCE	2.00	1.50	0.50	0.50

**Summary Table**

Sl. No.	Name	Total Built Up Area (Sq.ft)	Proposed FAR Area (Sq.ft)	Total FAR Area (Sq.ft)	Tent (No.)
1	GROUND FLOOR AREA	781.50	781.50	781.50	11
2	FIRST FLOOR AREA	781.50	781.50	781.50	11
3	TERRACE FLOOR AREA	781.50	781.50	781.50	11
4	TOTAL	2344.50	2344.50	2344.50	33

**Building A (LAXMI NARAYAN)**

FLOOR	Name	CONCRETE TYPE	Usable Area (Sq.ft)	Net Area (Sq.ft)	No. of Rooms	No. of Elements
GROUND	SPLIT 1	FLAT	148.21	148.21	1	1
1ST	SPLIT 1	FLAT	148.21	148.21	1	1