

Proposal Basic Information

Proposal File No.	MADA/P/0249/2022
Owner Name	SMT. SUNITA VERMA
Khata No	57, 61, 24(old) 35(new)
Plot No	1591, 1577, 1587, 1585(old) 1854(new)
Village Name	Kurmidih
Use	Residential
SubUse	Bungalow/ Dwelling / Non Apartment

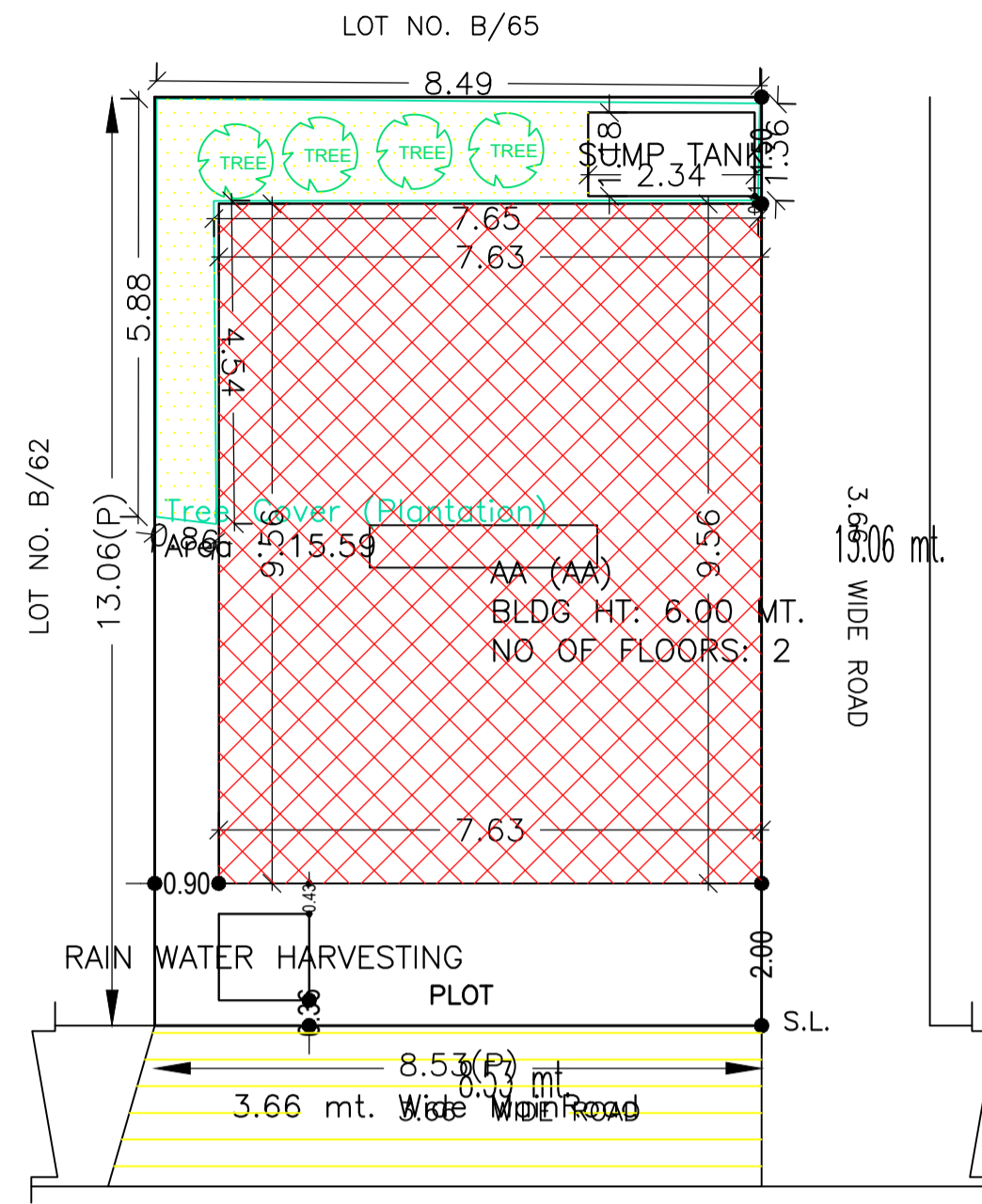

SITE PLAN

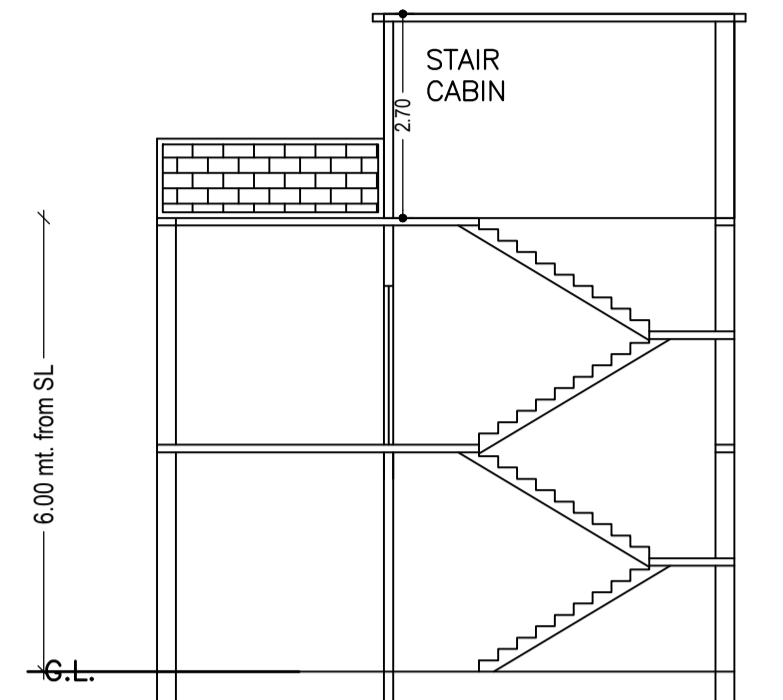

SECTION ON X-X

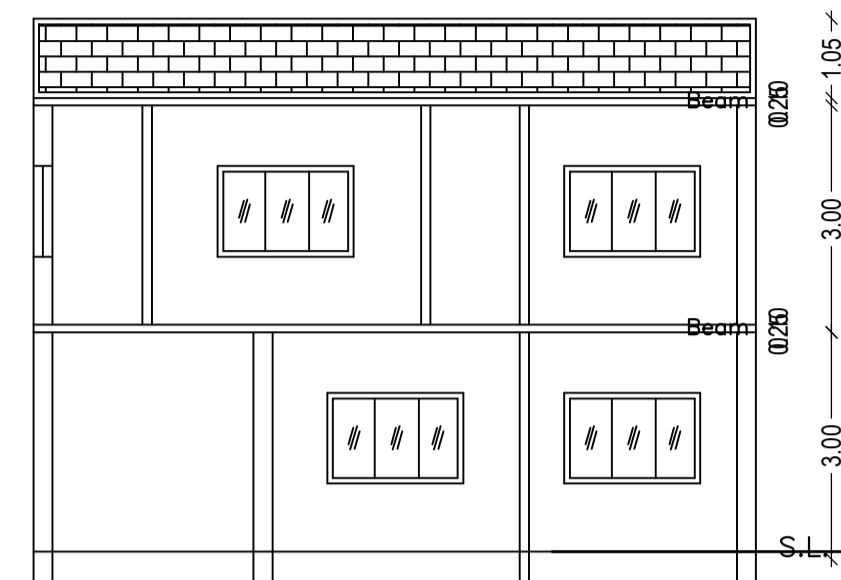

SECTION ON Y-Y

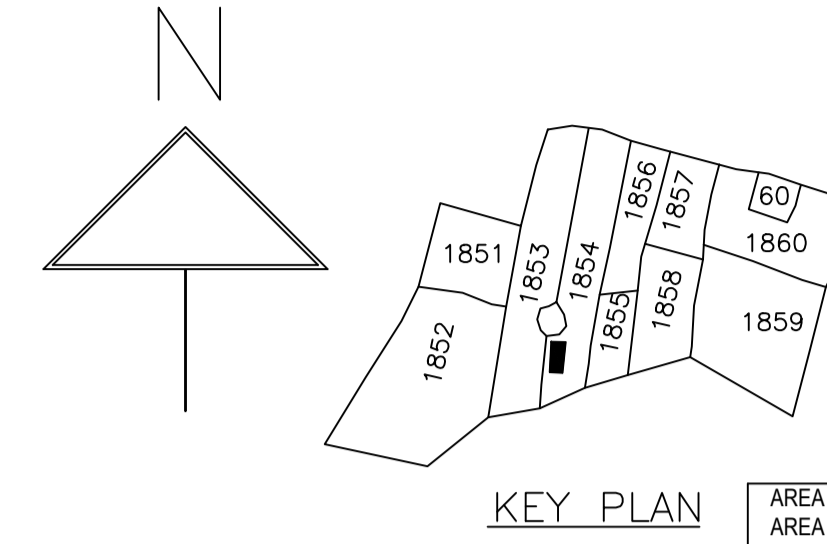

KEY PLAN

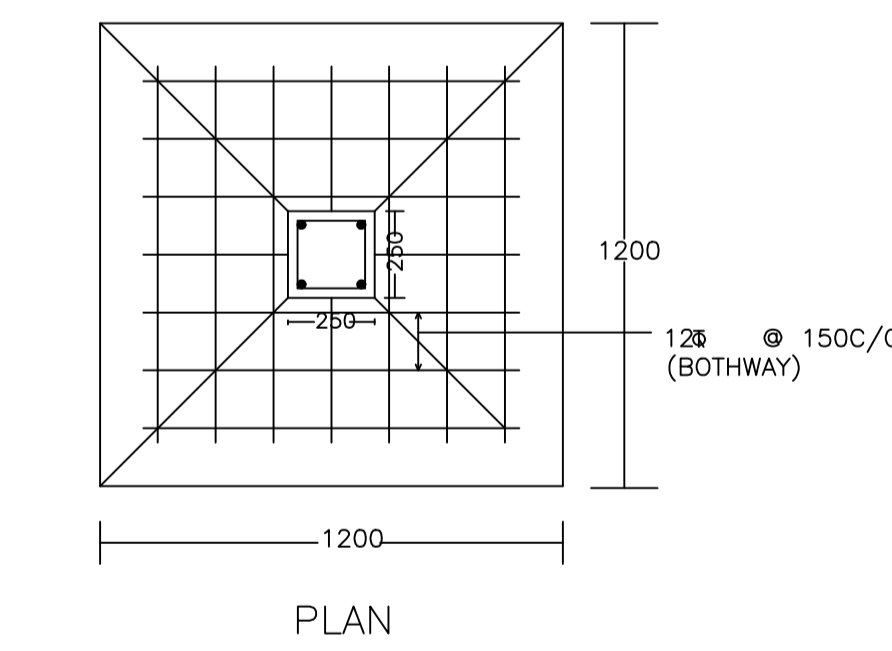
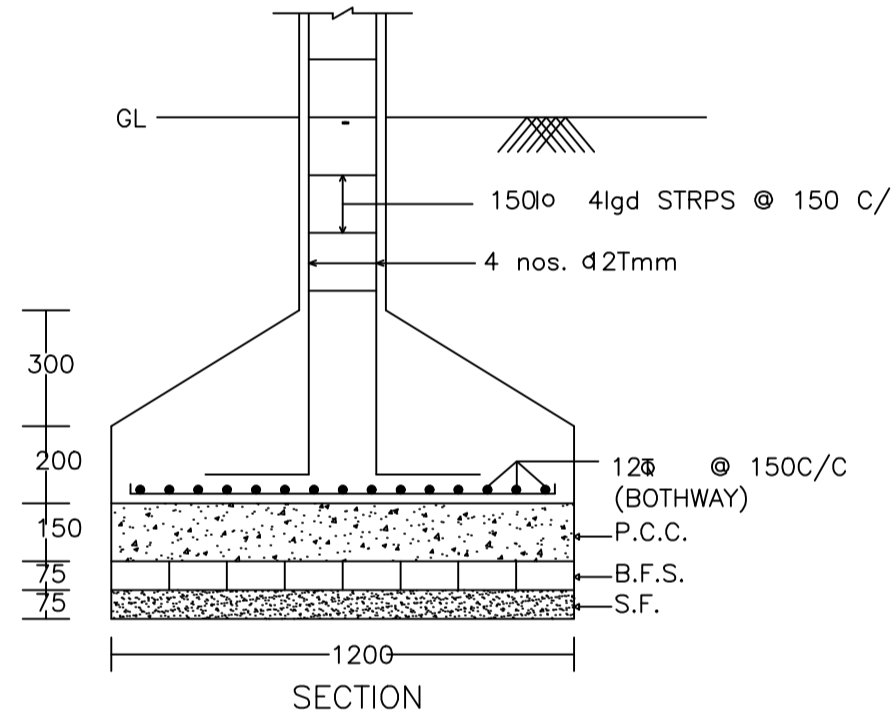
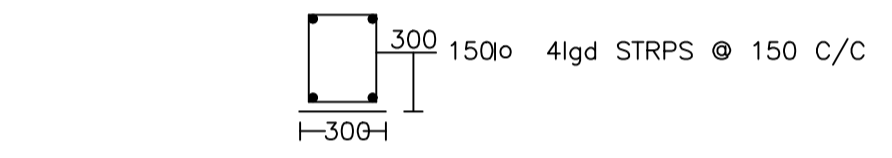

DETAIL OF COLUMNS

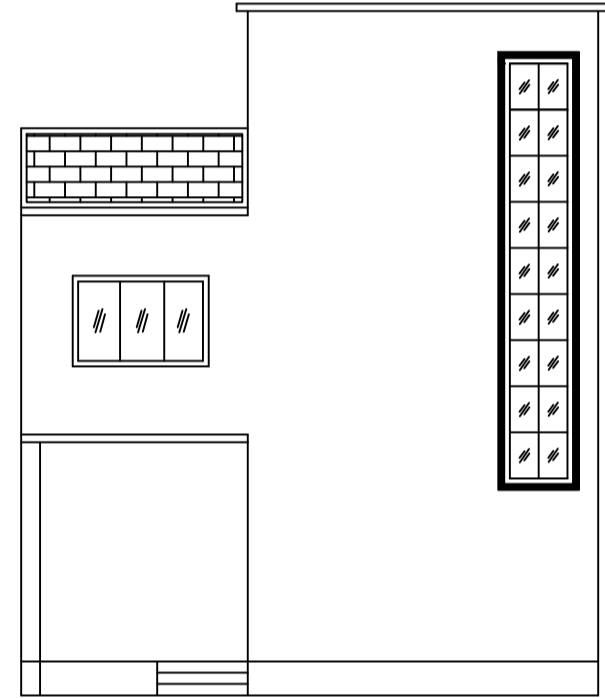

FRONT ELEVATION

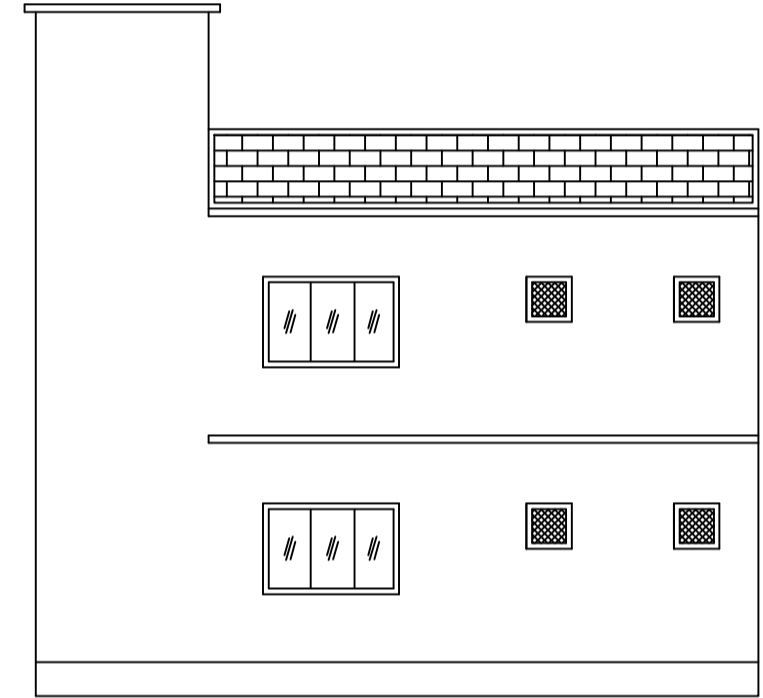

RIGHT SIDE ELEVATION

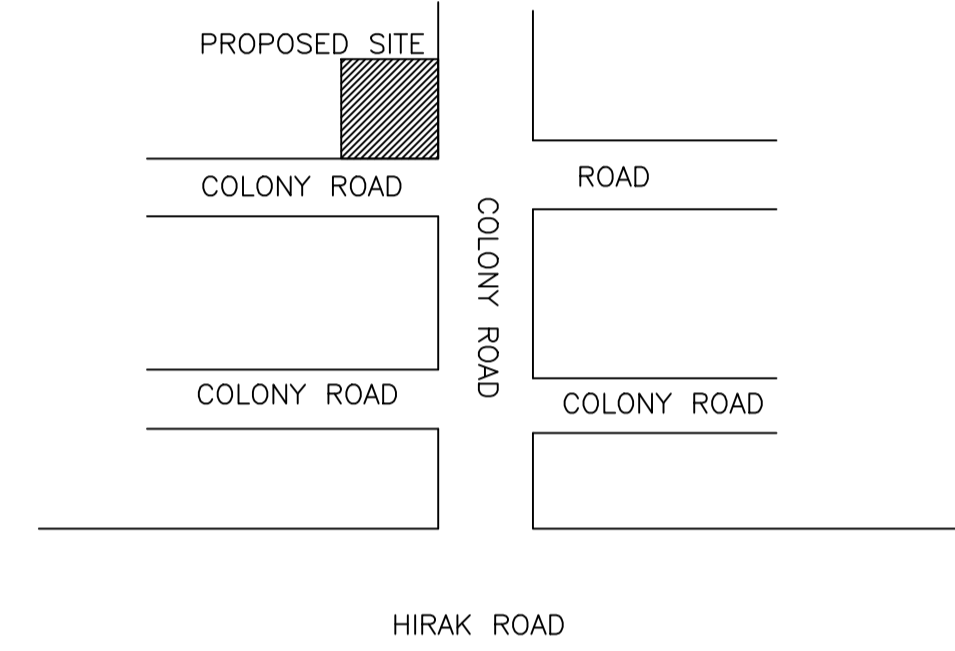

LOCATION PLAN

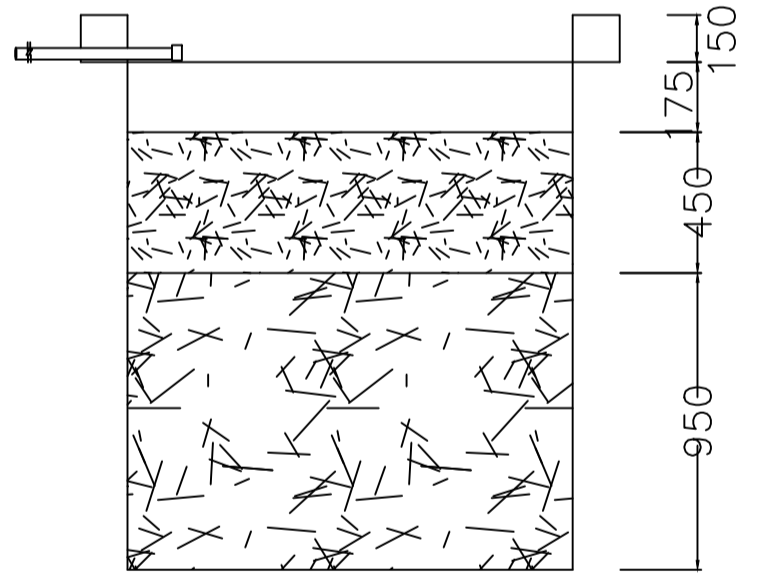

SECTION AT Y-Y

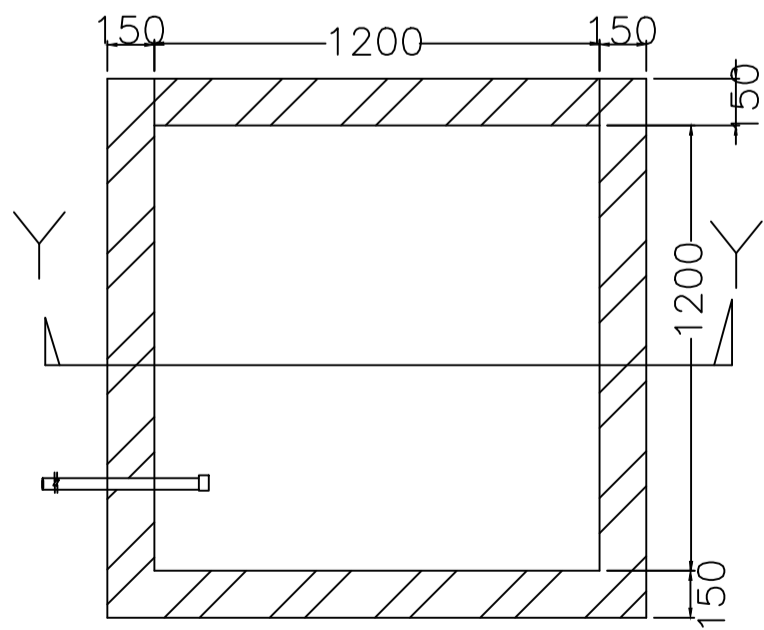

PLAN OF RECHARGE WELL

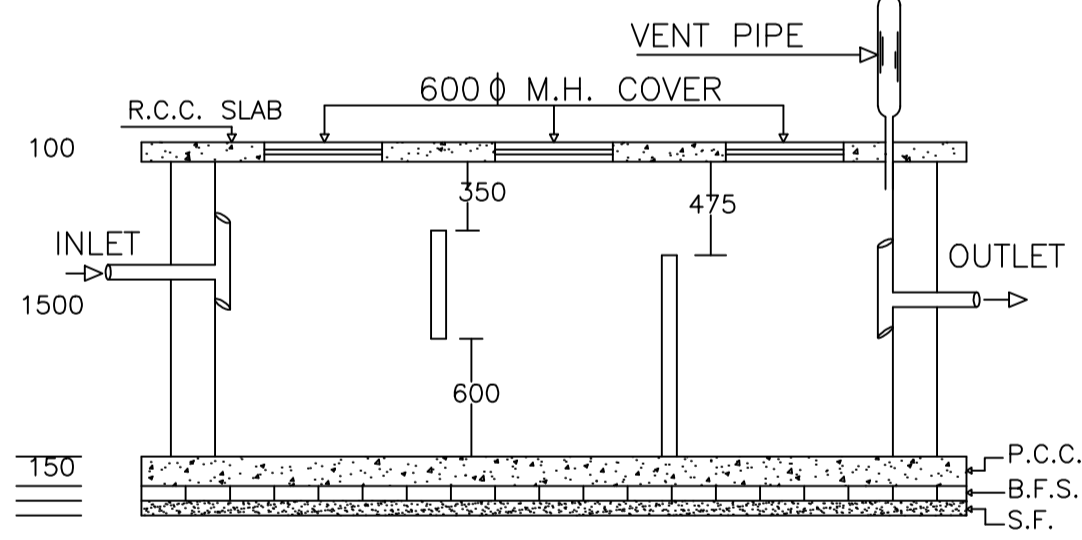

PLAN OF SEPTIC TANK

AREA STATEMENT MINERAL AREA DEVELOPMENT AUTHORITY	VERSION NO.: 1.0.62	VERSION DATE: 16/10/2020
PROJECT DETAIL:	Region: JHARKHAND URBAN LOCAL BODIES	Plot Use: Residential
Authority: MINERAL AREA DEVELOPMENT AUTHORITY	District: DHANBAD	Plot SubUse: Bungalow/ Dwelling / Non Apartment
Inward No: MADA/BP/0249/2022	Plot/ReligiousStructure: NA	Plot/ReligiousStructure: NA
Application Type: General Proposal	North: Plot No. - 3.66 WIDE ROAD	Plot/SubPlot No: 1591, 1577, 1587, 1585(old) 1854(new)
Project Type: Building Permission	South: Plot No. - LOT NO. B/65	Plot Area: 111.43
Nature of Development: New	East: Plot No. - LOT NO. B/62	Plot Area for FAR (Net Plot Area + Road Widening Area): 111.43
Location of Development Area: Old Area	West: Road Width - 3.66 WIDE ROAD	
AREA DETAILS:		SQ.MT.
AREA OF PLOT (Minimum)	(A)	111.43
NET AREA OF PLOT (Gross Plot Area - Deduction from Gross Plot area)	(A-Deductions)	111.43
Deduction for Balance Plot Area (from Gross Plot Area)		
Common Plot		15.59
Total		15.59
BALANCE AREA OF PLOT (Net Plot Area - Recreational/Amenity space)	(A-Deductions)	95.84
PLOT AREA FOR COVERAGE (Net Plot Area)	(A-Deductions)	111.43
Plot Area for FAR (Net Plot Area + Road Widening Area)	(A-Deductions)	111.43
COVERAGE CHECK		
Permissible Coverage area (70.00 %)		78.00
Proposed Coverage Area (65.48 %)		72.96
Total Prop. Coverage Area (65.48 %)		72.96
Balance coverage area (4.52 %)		5.04
FAR CHECK		
Perm. FAR Area (1.50)		167.15
Total Perm. FAR area		167.15
Residential FAR		145.91
Proposed FAR Area		145.91
Total Proposed FAR Area		145.91
Consumed FAR (Factor)		1.31
Balance FAR Area		21.24
BUILT UP AREA CHECK		
Total Proposed BuiltUp Area		145.92
ARCHITECT (Regd)		RAJEEV RANJAN SINGH
ENGINEER (Regd)		
SUPERVISOR (Regd)		
OWNER (Regd)		SMT. SUNITA VERMA
DEVELOPMENT AUTHORITY		LOCAL BODY

Floor Name	Building Name		Total	
	Proposed Built Up Area (Sq.mt.)	Proposed FAR Area (Sq.mt.)	Total Proposed Built Up Area (Sq.mt.)	Total FAR Area (Sq.mt.)
Ground Floor	72.96	72.96	72.96	72.96
First Floor	72.96	72.96	72.96	72.96
Terrace Floor	0.00	0.00	0.00	0.00
Total:	145.92	145.92	145.92	145.92

Building Name	Building Use	Building SubUse	Building Structure
AA (AA)	Residential	Bungalow/ Dwelling / Non Apartment	Non-Highrise

Building	No. of Same Bldg	Total Built Up Area (Sq.mt.)	Proposed FAR Area (Sq.mt.)	Total FAR Area (Sq.mt.)	Total Consumed Additional FAR Area (Sq.mt.)	Trmt (No.)
AA (AA)	1	145.92	145.92	145.92	145.92	01
Grand Total:	1	145.92	145.92	145.92	145.92	01

FLOOR	Name	UnitBUA Type	UnitBUA Area	Carpet Area	No. of Rooms	No. of Tenement
GROUND FLOOR PLAN	SPLIT AA	FLAT	145.91	145.60	7	1
FIRST FLOOR PLAN	SPLIT AA	FLAT	0.00	0.00	8	0
Total:	-	-	145.91	145.60	15	1

BUILDING NAME	NAME	LENGTH	HEIGHT	NOS
AA (AA)	V	0.60	1.20	04
AA (AA)	W1	0.88	1.20	02
AA (AA)	W	1.80	1.20	09

Floor Name	Total Built Up Area (Sq.mt.)	Proposed FAR Area (Sq.mt.)	Total FAR Area (Sq.mt.)	Total Consumed Additional FAR Area (Sq.mt.)	Trmt (No.)
Ground Floor	72.96	72.96	72.96	72.96	01
First Floor	72.96	72.96	72.96	72.96	00
Terrace Floor	0.00	0.00	0.00	0.00	00
Total:	145.92	145.92	145.92	145.92	01
Total Number of Same Buildings	1				
Total:	145.92	145.92	145.92	145.92	01

BUILDING NAME	NAME	LENGTH	HEIGHT	NOS
AA (AA)	D3	0.75	2.10	02
AA (AA)	D3	0.76	2.10	01
AA (AA)	D3	0.78	2.10	02
AA (AA)	D2	0.90	2.10	02
AA (AA)	D	1.05	2.10	05
AA (AA)	D1	1.20	2.10	01

PLOT BOUNDARY	Black
ABUTTING ROAD	Green
PROPOSED CONSTRUCTION	Red
COMMON PLOT	Yellow
ROAD WIDENING AREA	Blue
EXISTING (To be retained)	Orange
EXISTING (To be demolished)	Light Blue

WATER HARVESTING

LTP NAME AND SIGNATURE	STRUCTURAL ENG'S NAME AND SIGNATURE	BUILDER NAME AND SIGNATURE	DIGITAL SIGNATURE
RAJEEV RANJAN SINGH MADA/ENG/0004/2019			

Proposal Basic Information	
Proposal File No.	MADA/P/0249/2022
Owner Name	SMT. SUNITA VERMA
Khata No	57, 61, 24(old) 35(new)
Plot No	1591, 1577, 1587, 1585(old) 1854(new)
Village Name	Kurmidih
Use	Residential
SubUse	Bungalow/ Dwelling / Non Apartment

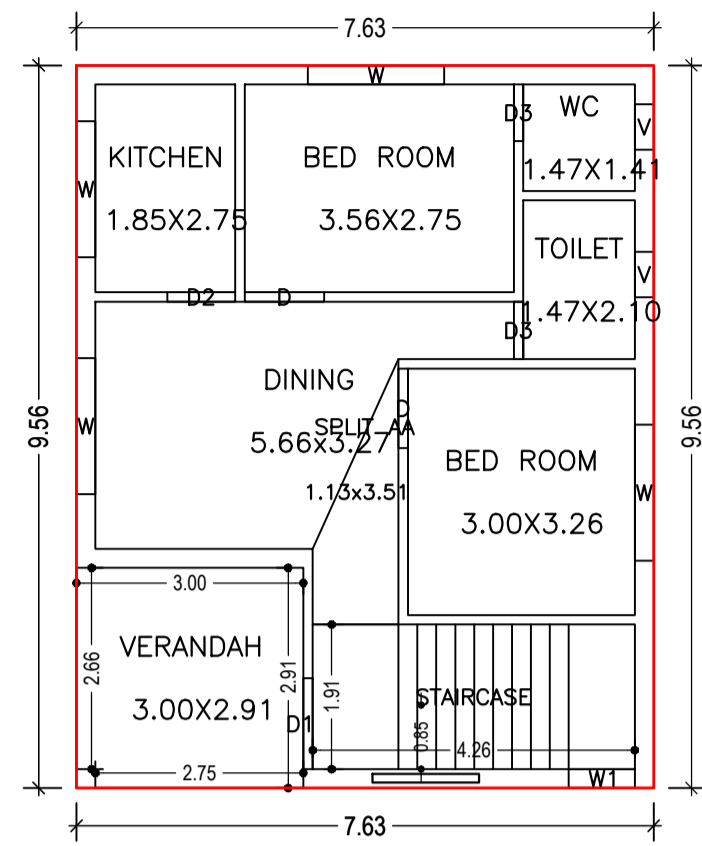

GROUND FLOOR PLAN
(Proposed)
(SCALE 1:100)

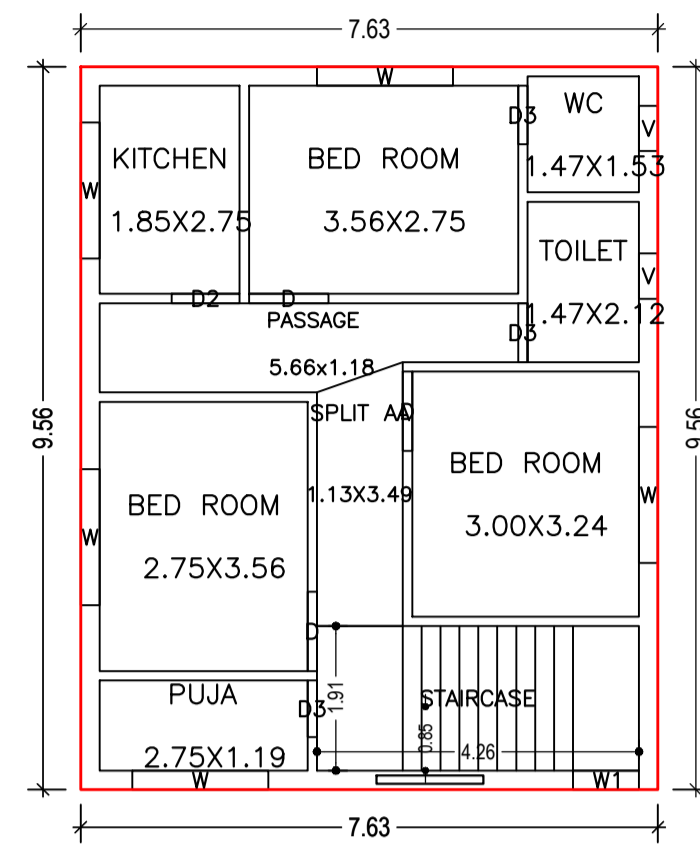

FIRST FLOOR PLAN
(Proposed)
(SCALE 1:100)

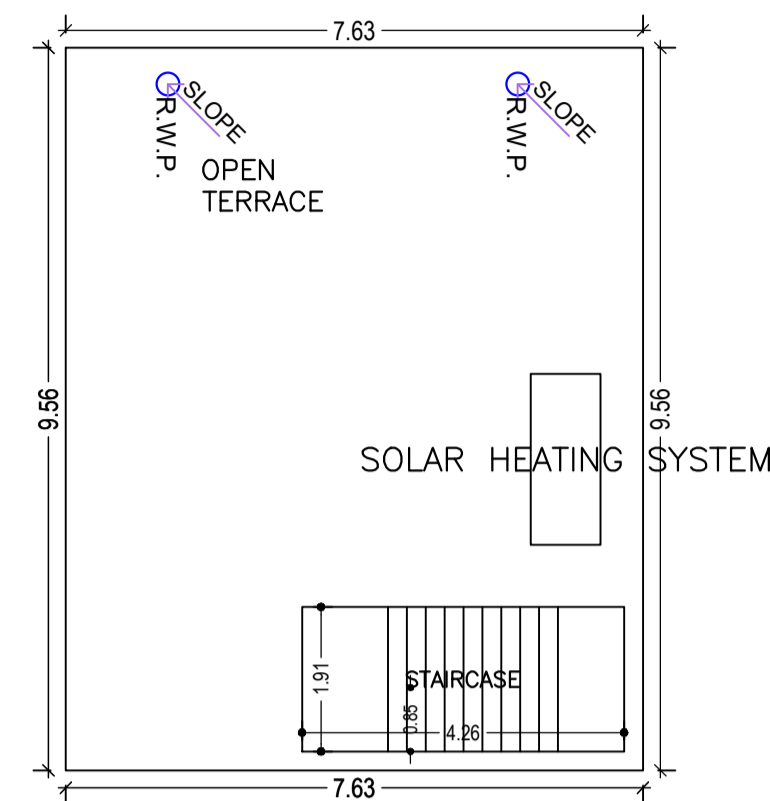

TERRACE FLOOR PLAN
(SCALE 1:100)

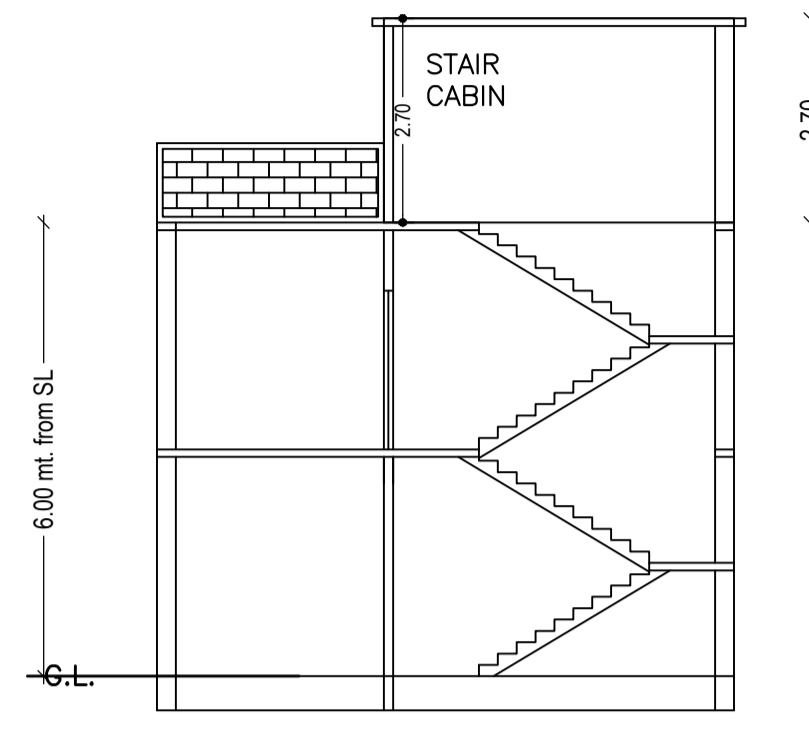

SECTION ON X-X

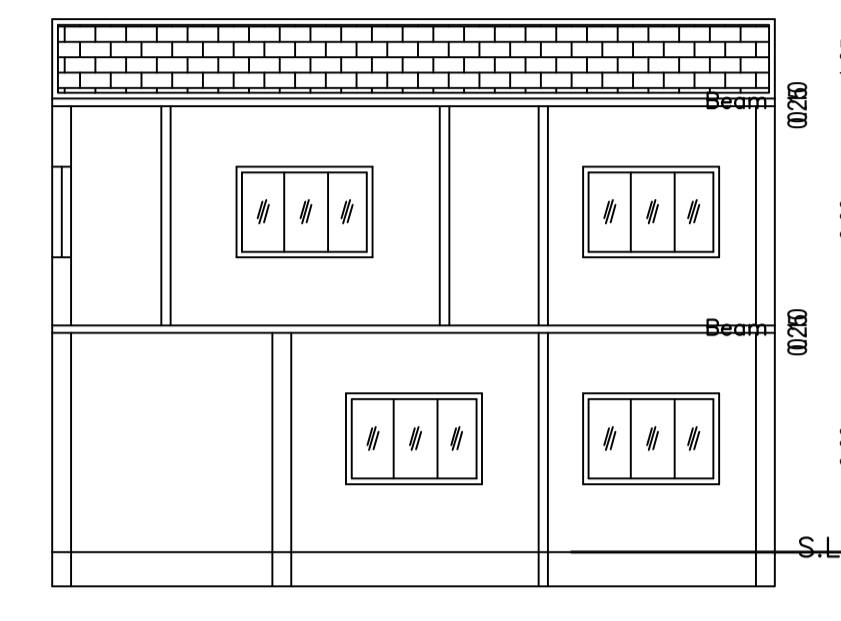

SECTION ON Y-Y

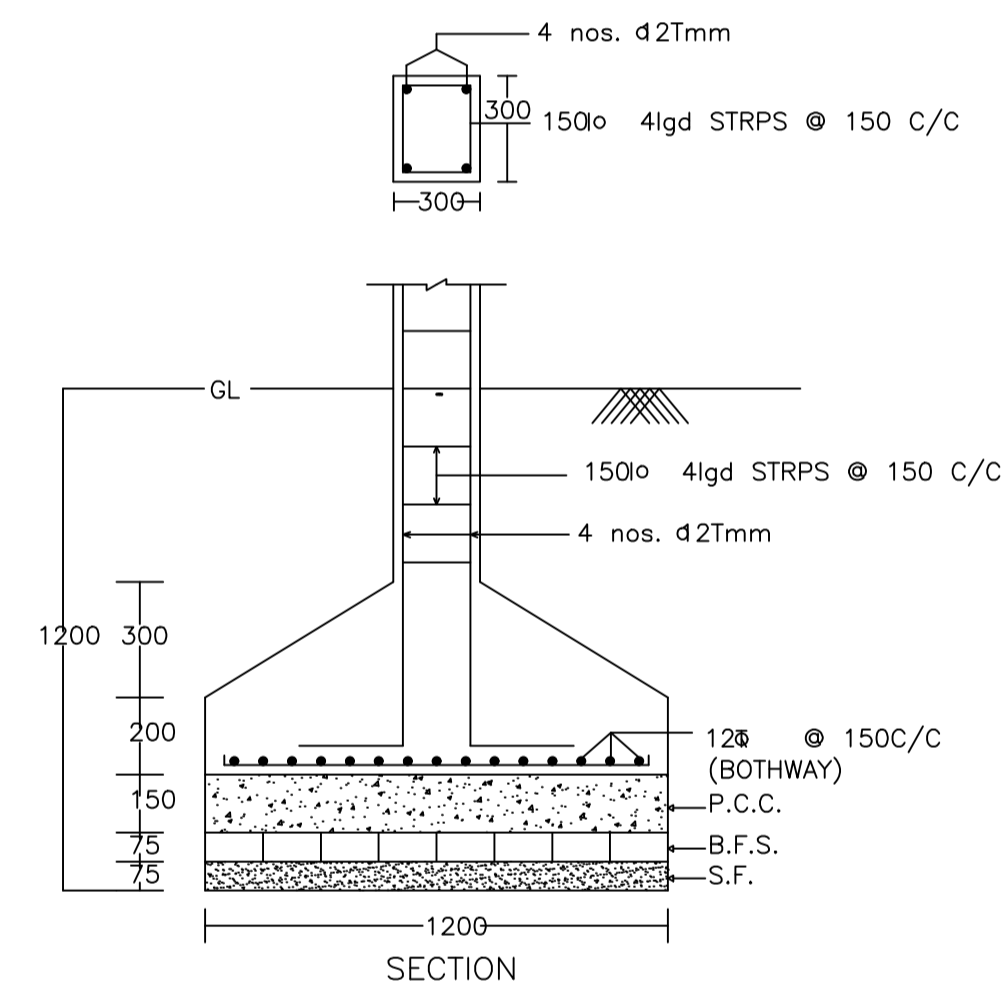

SECTION

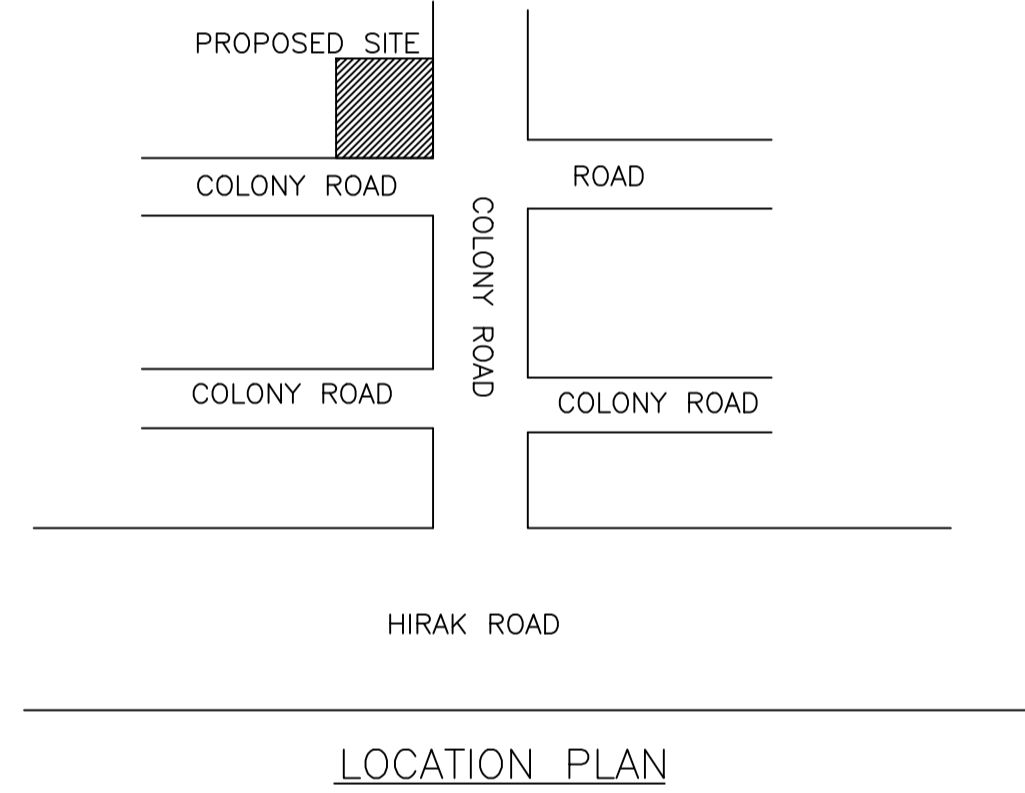

LOCATION PLAN

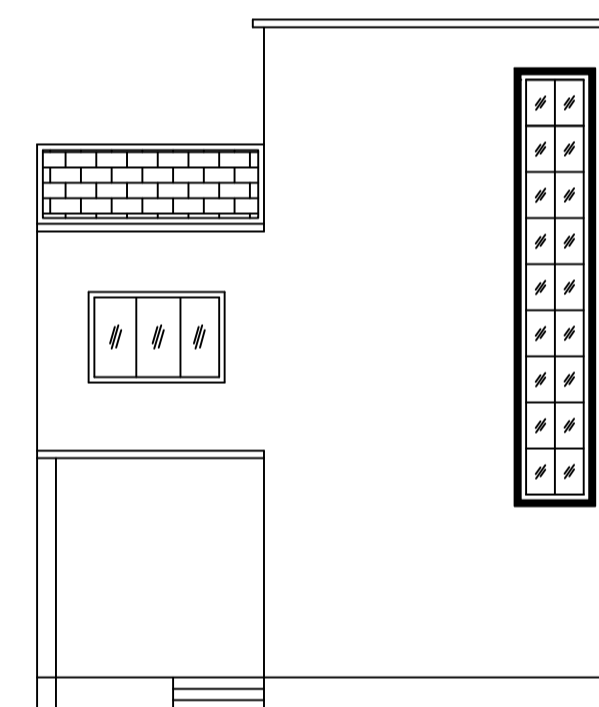

FRONT ELEVATION

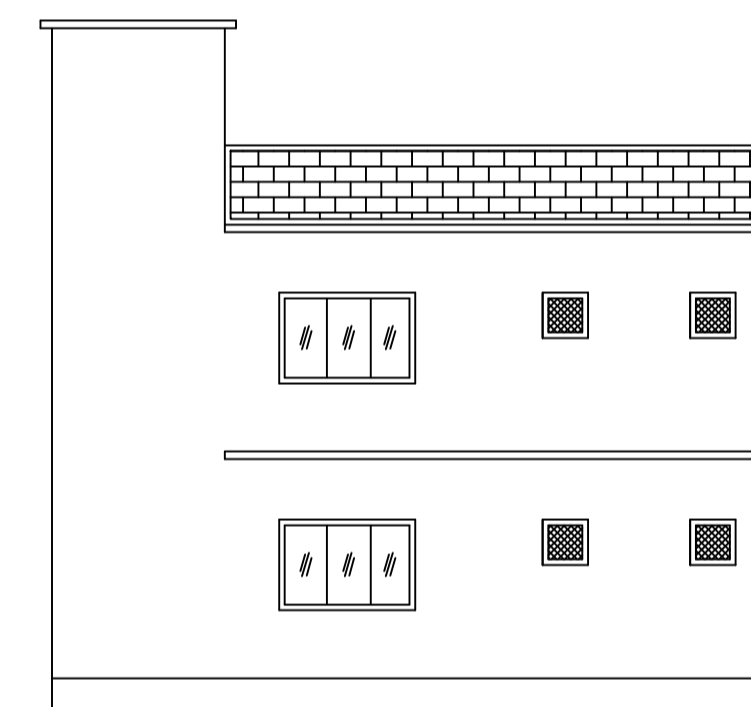

RIGHT SIDE ELEVATION

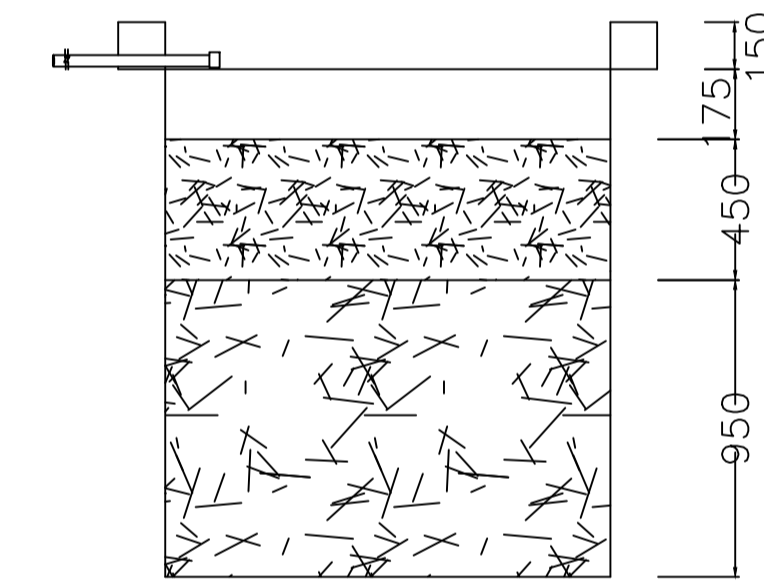

SECTION AT Y-Y

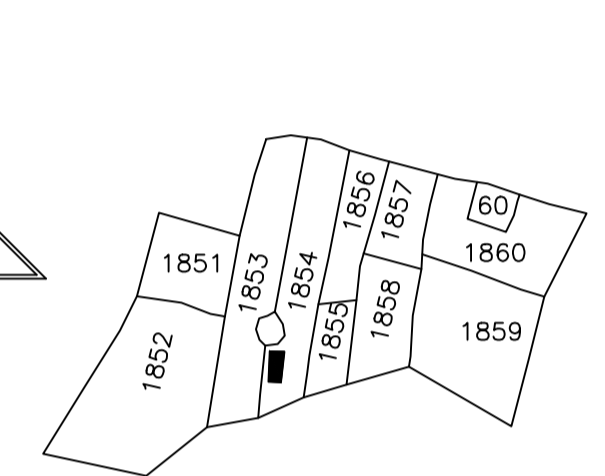

KEY PLAN

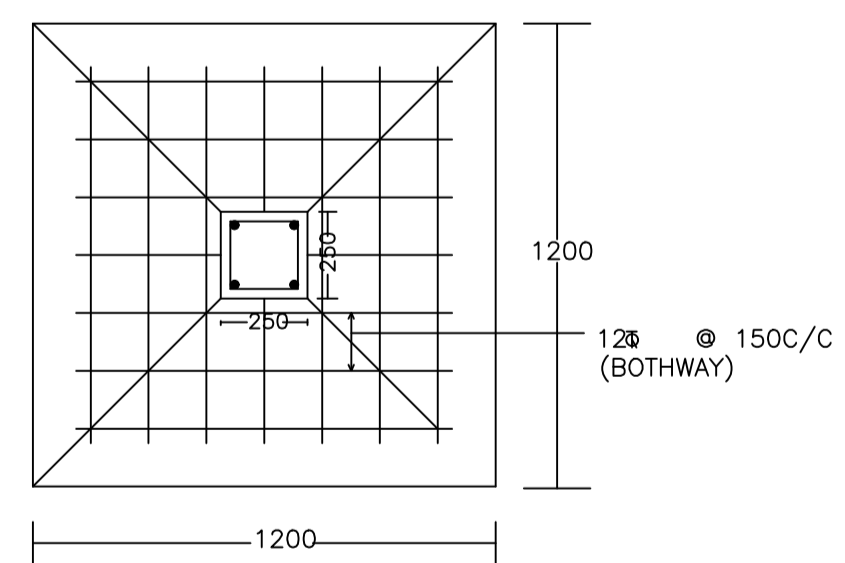

PLAN

DETAIL OF COLUMNS

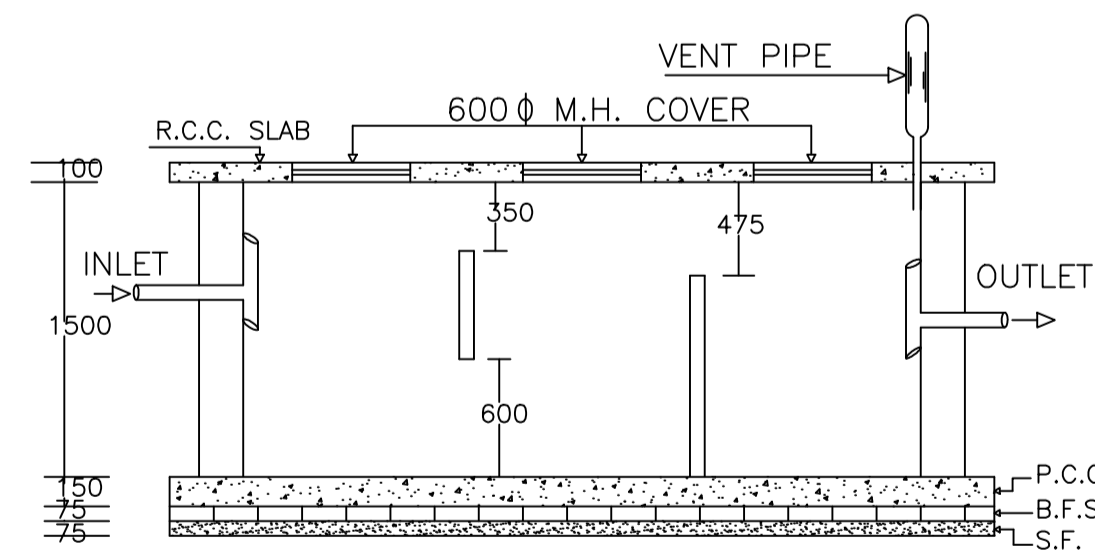

PLAN OF RECHARGE WELL

WATER HARVESTING

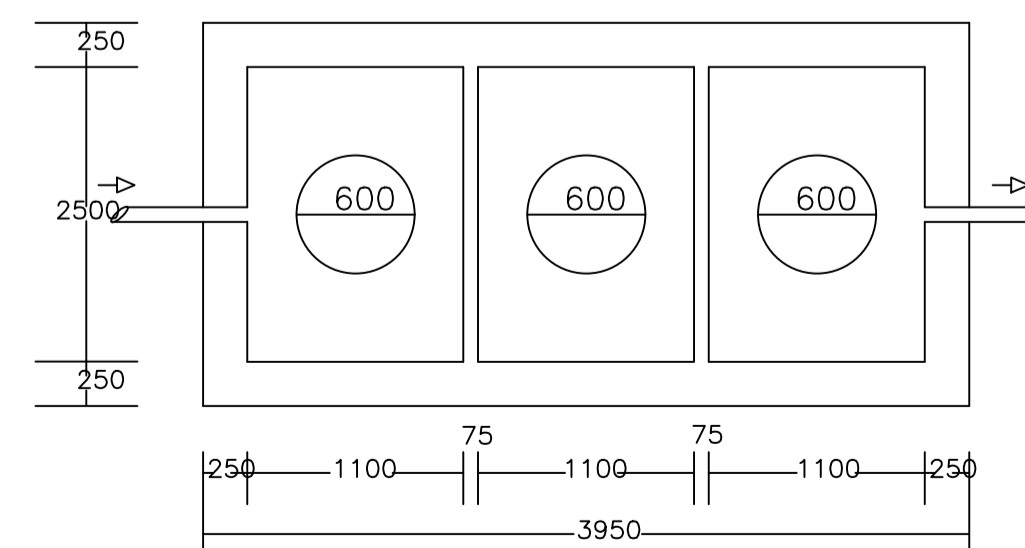

PLAN OF SEPTIC TANK

LTP NAME AND SIGNATURE	STRUCTURAL ENG'S NAME AND SIGNATURE	BUILDER NAME AND SIGNATURE	DIGITAL SIGNATURE
RAJEEV RANJAN SINGH MADA/ENG/0004/2019			