

Project Title - SRI CHANDRA SHEKHAR PRASAD

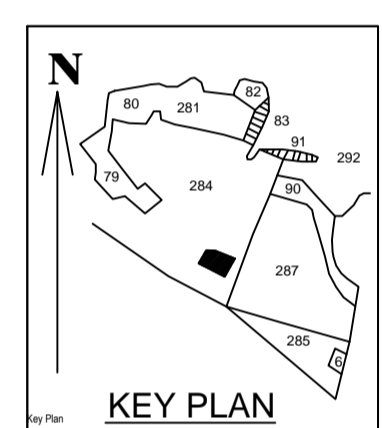
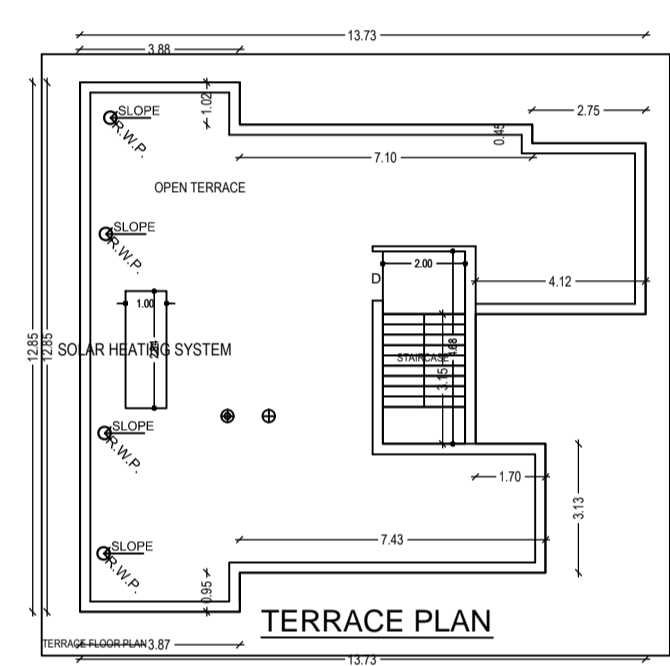
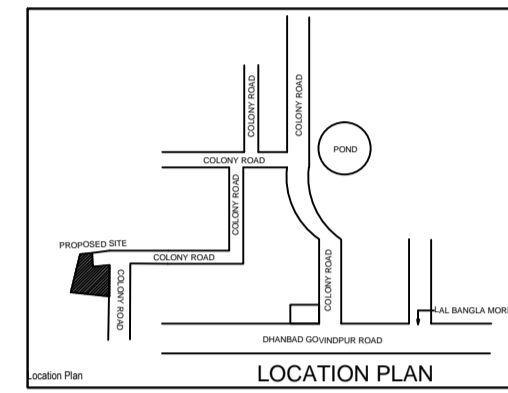
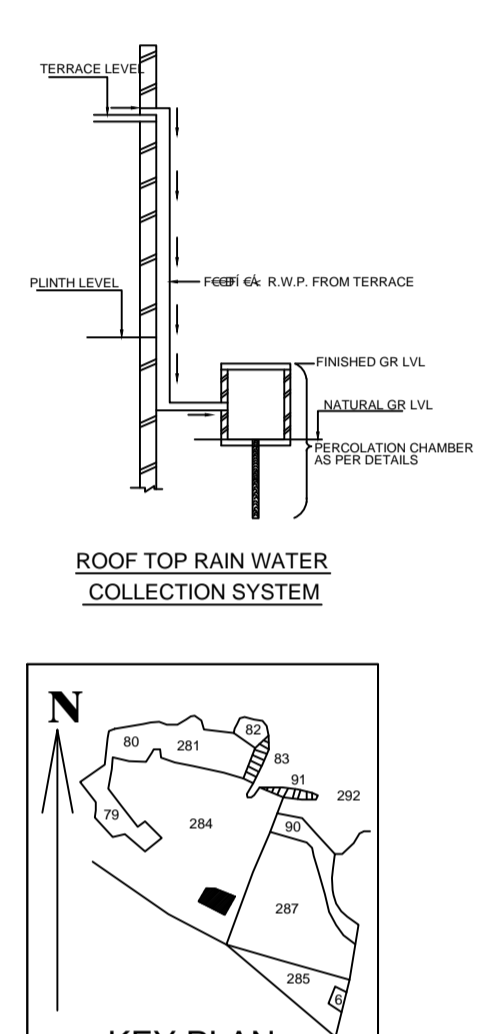
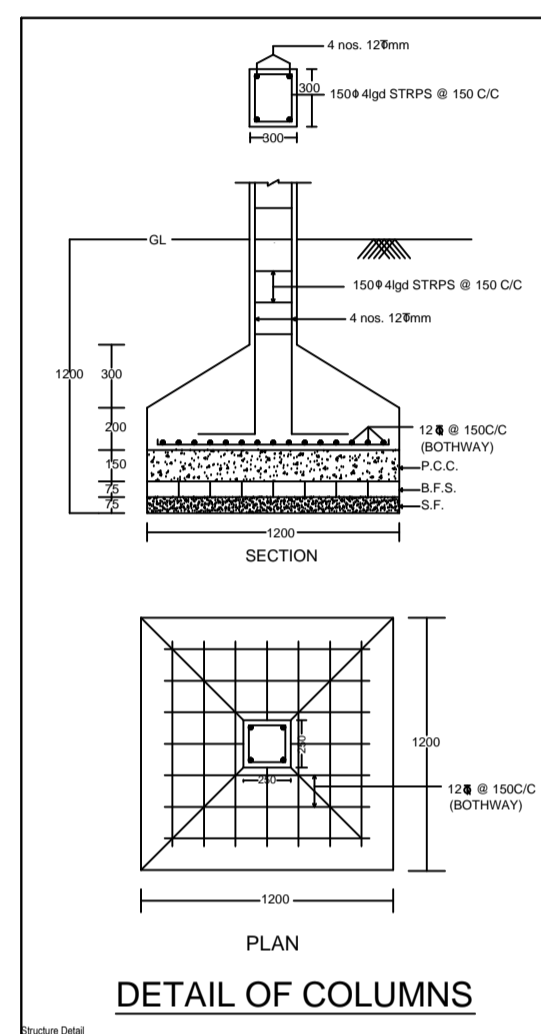
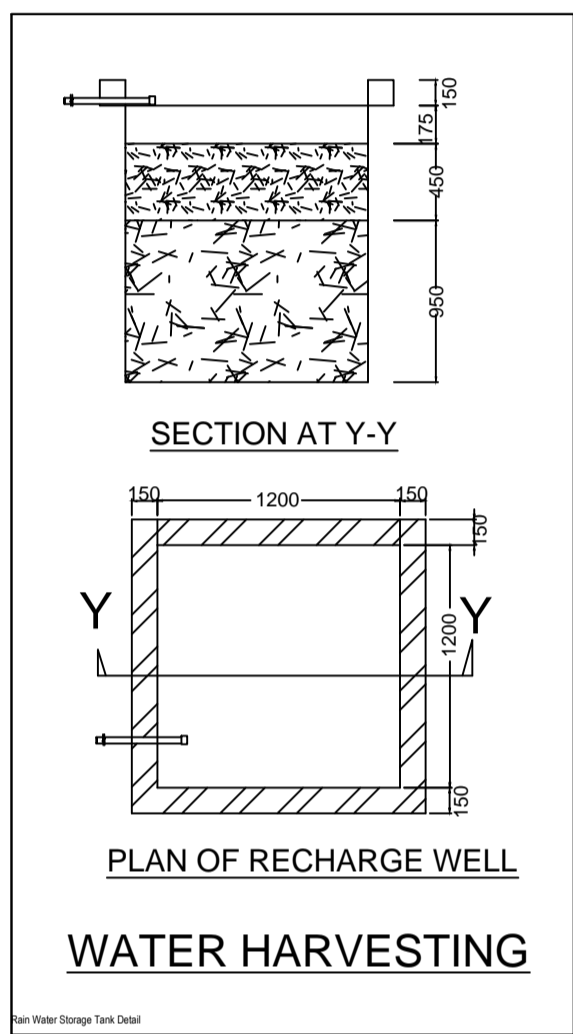
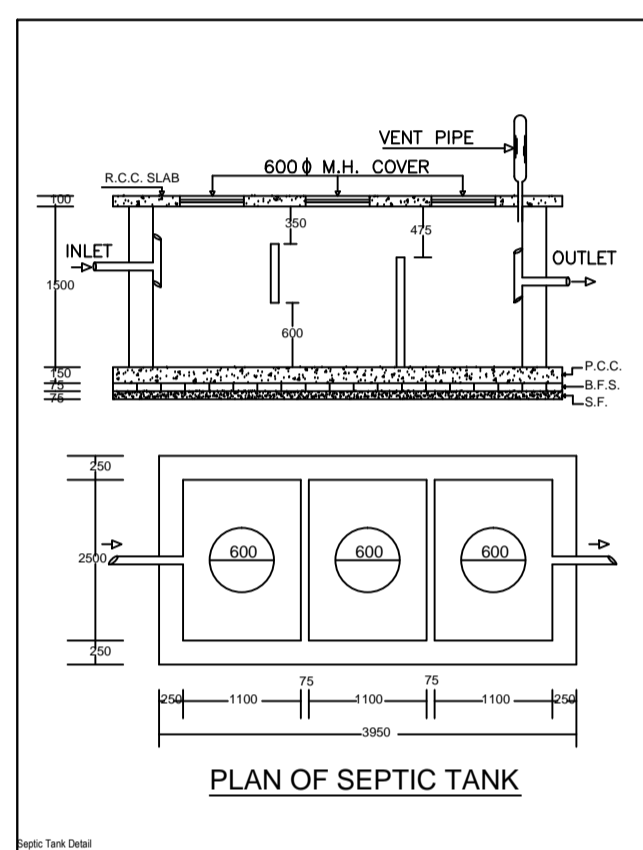
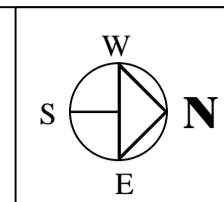
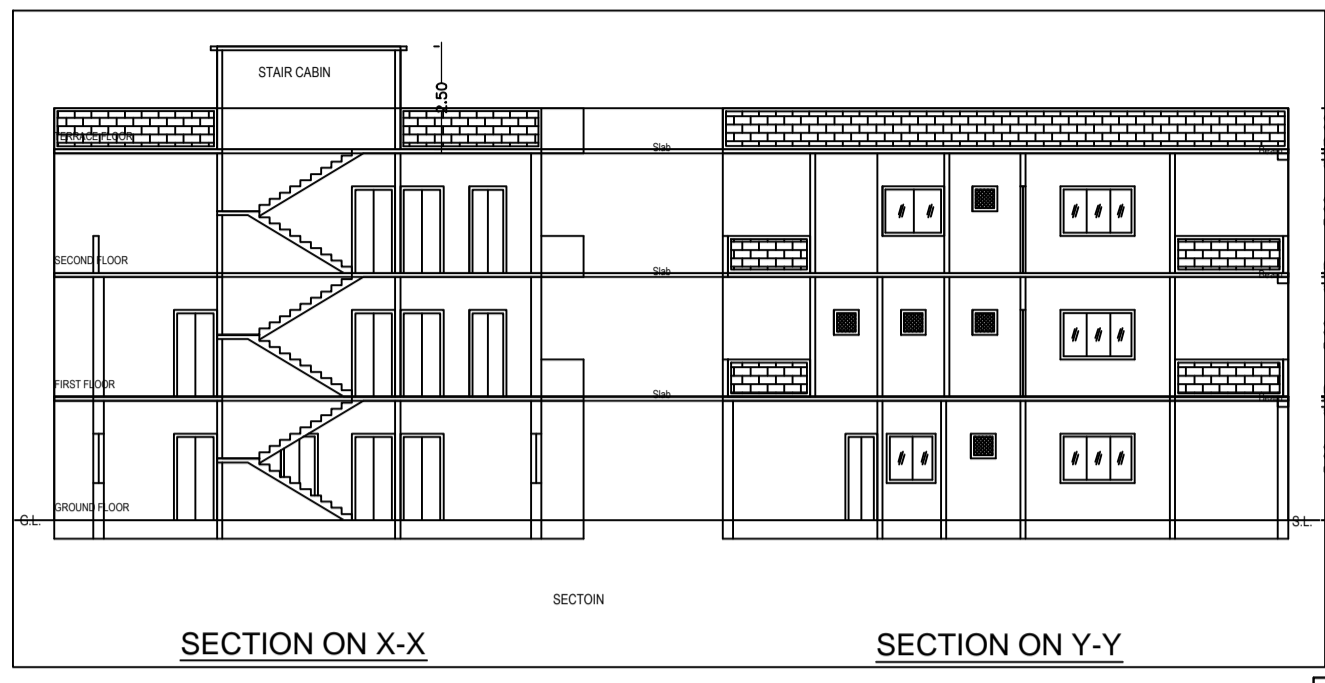
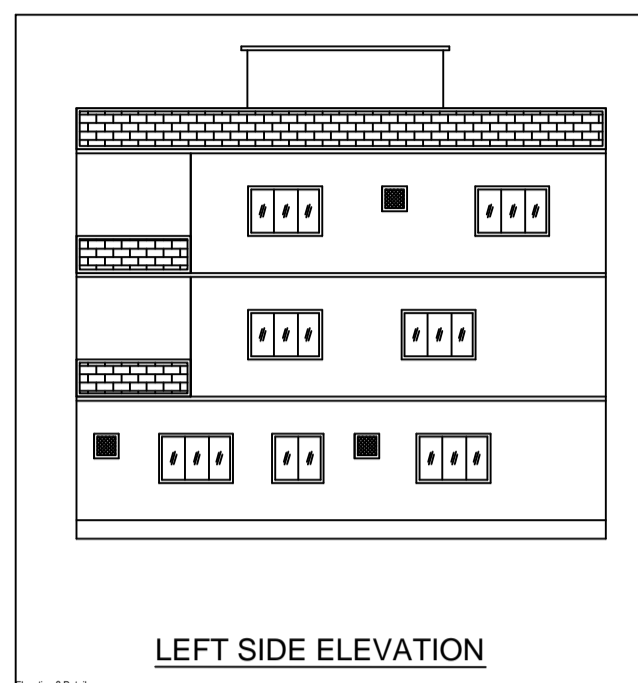
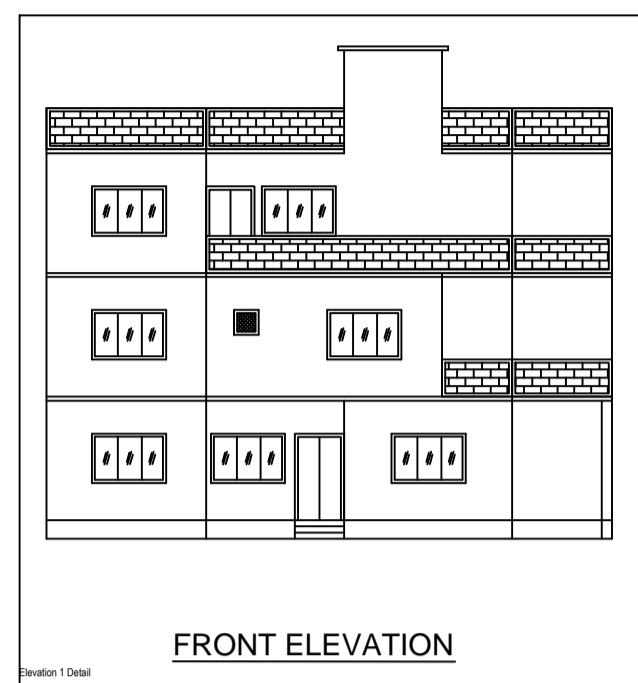

BRIEF SPECIFICATION

FOUNDATION-----CEMENT CONCRETE (1:1.5:3)
 BRICK WORK IN FOUNDATION & SUPERSTRUCTURE
 FIRST CLASS BRICK WORK IN CEMENT MORTAR (1:2:4)
 D.P.C.-----25 D.P.C. IN CEMENT CONCRETE (1:2:4)
 FLOOR-----25 I.P.S. OVER 75 P.C.C.
 ROOF-----100 THK. R.C.C. ROOF (1:1.5:3)
 LINTEL-----150 THK. R.C.C. LINTEL (1:1.5:3)
 STAIRS-----RISE-- 150, TREAD-- 250

DETAILS OF AREA

TOTAL AREA (AS PER DEED) 268.00 SQM.
 TOTAL AREA (AS PER SITE) 259.48 SQM.
 GROUND FLOOR AREA 135.10 SQM.
 FIRST FLOOR AREA 135.10 SQM.
 SECOND FLOOR AREA 113.33 SQM.
 TOTAL COVERED AREA 383.53 SQM.
 % PLINTH AREA 52.14 %
 FAR 1.48

SCHEDULE

D = 1.200X2.100 W = 1.800X1.200
 D1 = 1.050X2.100 W2 = 2.400X1.200
 D2 = 0.900X2.100 V = 0.600X0.600

TITLE OF DRAWING

PLAN OF PROPOSED RESIDENTIAL BUILDING OF SRI CHANDRA SHEKHAR PRASAD, S/O LATE HIRA LAL SAH, OF WEST KOIRIBANDH JHARIA, P.S.- JHARIA, DHANBAD, UNDER MOUZA - KANGALO, NO.- 128, KHATA NO.- 17, NEW KHATA NO.- 53, PLOT NO.- 284 NEW PLOT NO.- 348 IN THE DISTT. OF DHANBAD (JHARKHAND).

SIGNATURE OF OWNER

SIGNATURE OF ENGINEER

SCALE ALL DIMENSION ARE IN METRE

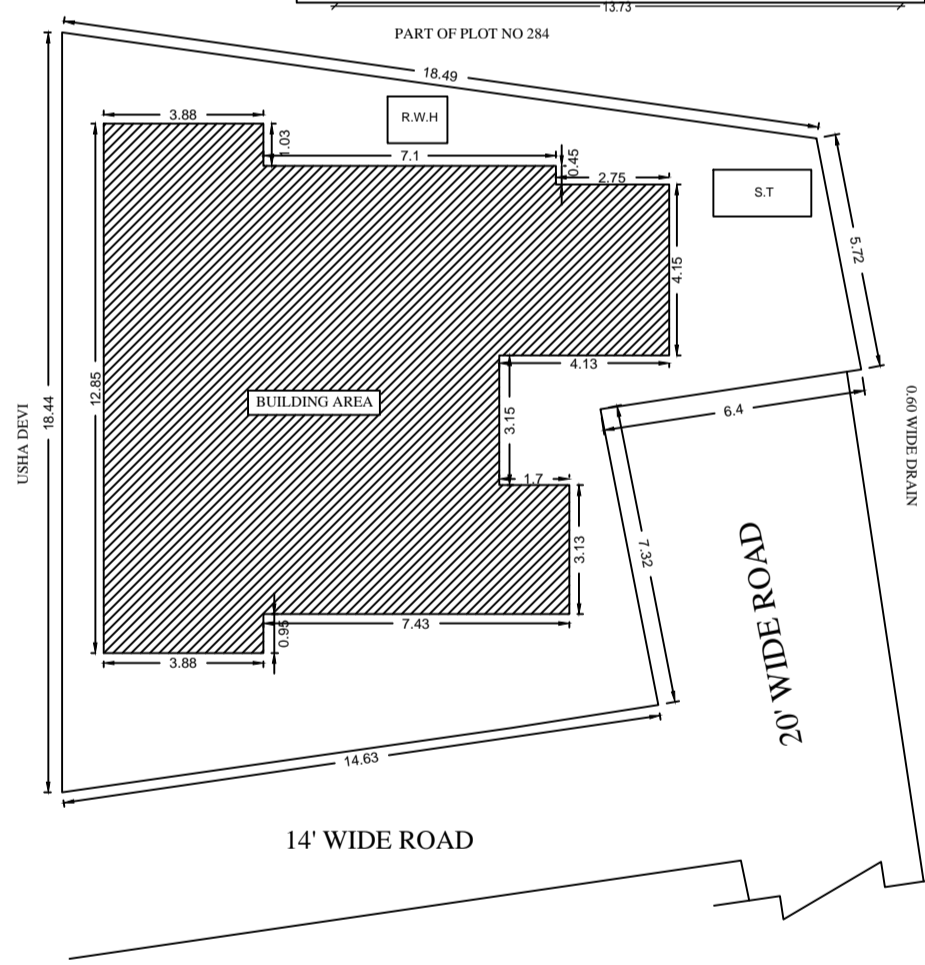
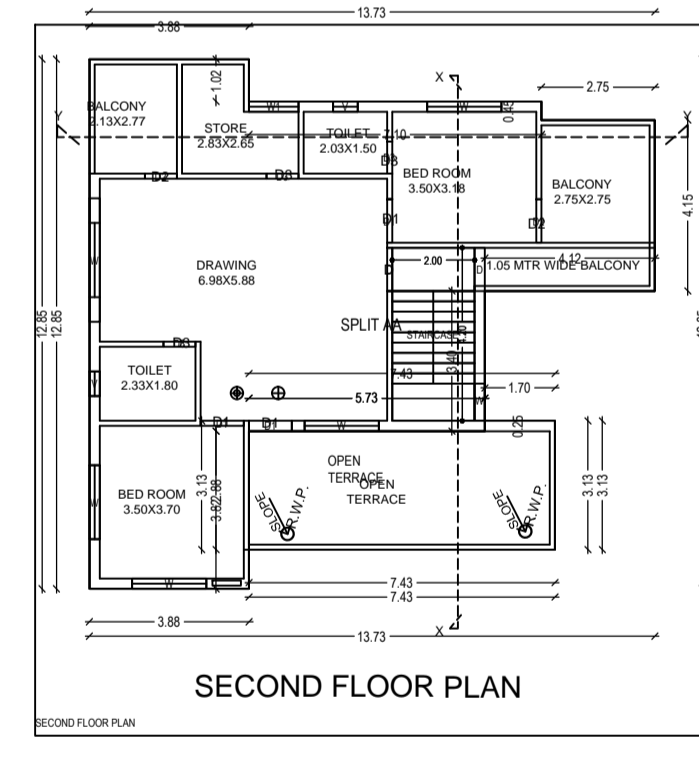
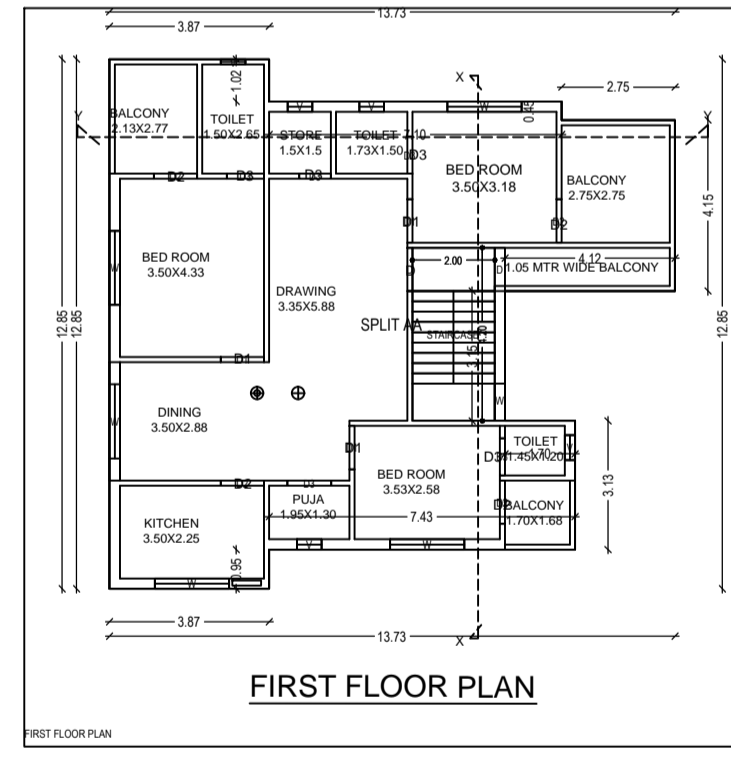
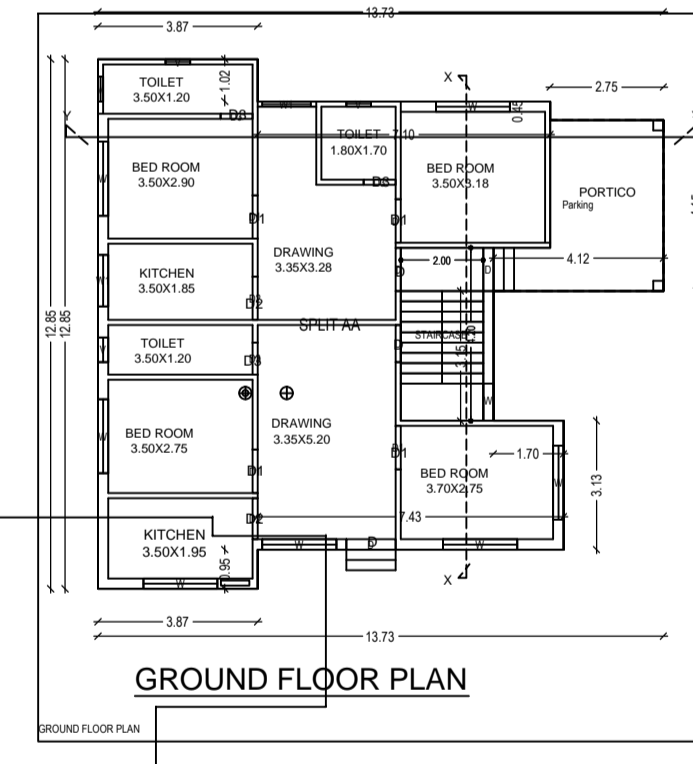
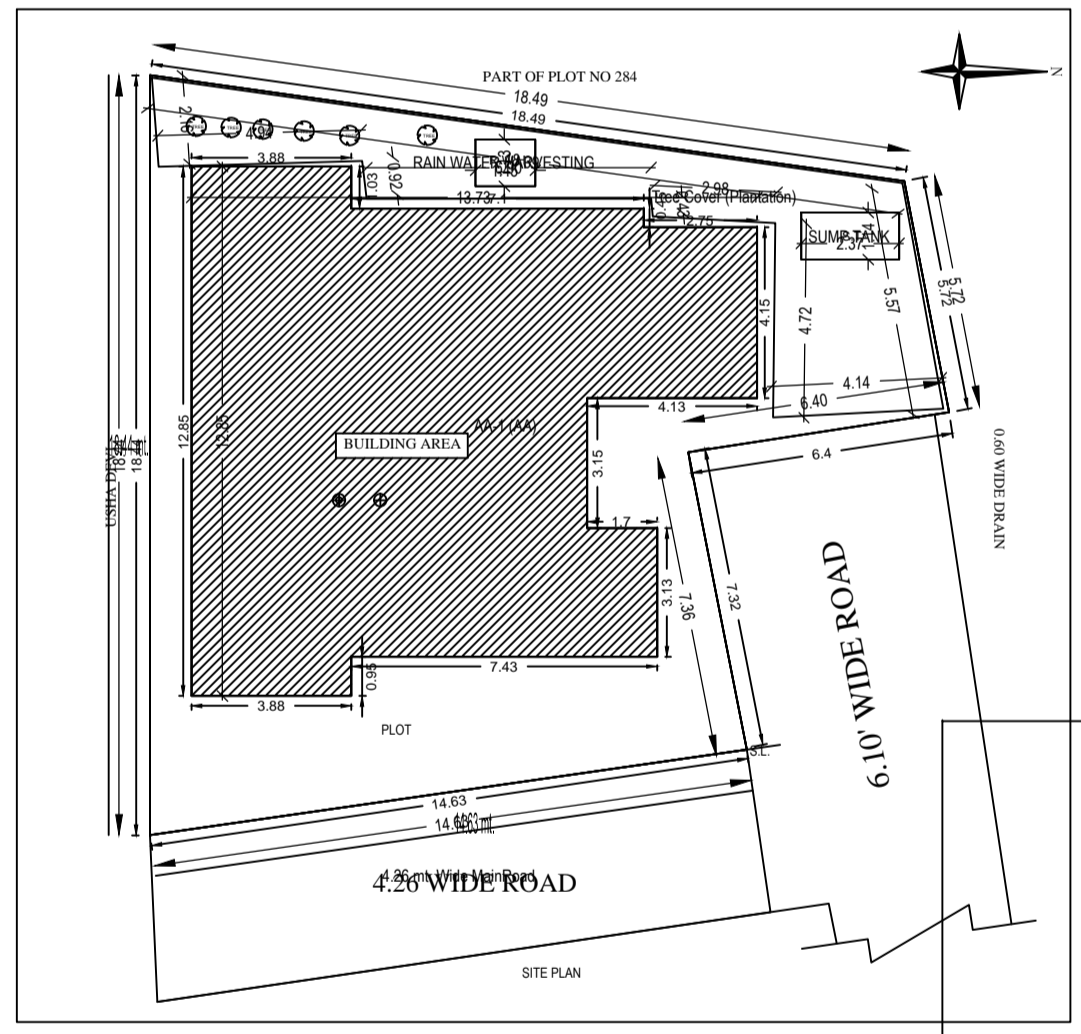

Building AA (AA)

Floor Name	Total Built Up Area (Sq.m)	Proposed FAR Area (Sq.m)	Total FAR Area (Sq.m)	Storey (No.)
Ground Floor	135.10	135.10	135.10	01
First Floor	135.10	135.10	135.10	02
Second Floor	113.33	113.33	113.33	03
Total Floor	383.53	383.53	383.53	03
Total Number of Same Buildings	1	383.53	383.53	03
Total	383.53	383.53	383.53	03

SCHEDULE OF JOINERY:

ITEM NO.	NAME	LENGTH	HEIGHT	NO.
1	PAINT	0.17	2.10	07
2	PAINT	0.17	2.10	07
3	PAINT	0.17	2.10	07
4	PAINT	0.17	2.10	07
5	PAINT	0.17	2.10	07
6	PAINT	0.17	2.10	07
7	PAINT	0.17	2.10	07
8	PAINT	0.17	2.10	07
9	PAINT	0.17	2.10	07
10	PAINT	0.17	2.10	07
11	PAINT	0.17	2.10	07
12	PAINT	0.17	2.10	07
13	PAINT	0.17	2.10	07
14	PAINT	0.17	2.10	07
15	PAINT	0.17	2.10	07
16	PAINT	0.17	2.10	07
17	PAINT	0.17	2.10	07
18	PAINT	0.17	2.10	07
19	PAINT	0.17	2.10	07
20	PAINT	0.17	2.10	07
21	PAINT	0.17	2.10	07
22	PAINT	0.17	2.10	07
23	PAINT	0.17	2.10	07
24	PAINT	0.17	2.10	07
25	PAINT	0.17	2.10	07
26	PAINT	0.17	2.10	07
27	PAINT	0.17	2.10	07
28	PAINT	0.17	2.10	07
29	PAINT	0.17	2.10	07
30	PAINT	0.17	2.10	07
31	PAINT	0.17	2.10	07
32	PAINT	0.17	2.10	07
33	PAINT	0.17	2.10	07
34	PAINT	0.17	2.10	07
35	PAINT	0.17	2.10	07
36	PAINT	0.17	2.10	07
37	PAINT	0.17	2.10	07
38	PAINT	0.17	2.10	07
39	PAINT	0.17	2.10	07
40	PAINT	0.17	2.10	07
41	PAINT	0.17	2.10	07
42	PAINT	0.17	2.10	07
43	PAINT	0.17	2.10	07
44	PAINT	0.17	2.10	07
45	PAINT	0.17	2.10	07
46	PAINT	0.17	2.10	07
47	PAINT	0.17	2.10	07
48	PAINT	0.17	2.10	07
49	PAINT	0.17	2.10	07
50	PAINT	0.17	2.10	07
51	PAINT	0.17	2.10	07
52	PAINT	0.17	2.10	07
53	PAINT	0.17	2.10	07
54	PAINT	0.17	2.10	07
55	PAINT	0.17	2.10	07
56	PAINT	0.17	2.10	07
57	PAINT	0.17	2.10	07
58	PAINT	0.17	2.10	07
59	PAINT	0.17	2.10	07
60	PAINT	0.17	2.10	07
61	PAINT	0.17	2.10	07
62	PAINT	0.17	2.10	07
63	PAINT	0.17	2.10	07
64	PAINT	0.17	2.10	07
65	PAINT	0.17	2.10	07
66	PAINT	0.17	2.10	07
67	PAINT	0.17	2.10	07
68	PAINT	0.17	2.10	07
69	PAINT	0.17	2.10	07
70	PAINT	0.17	2.10	07
71	PAINT	0.17	2.10	07
72	PAINT	0.17	2.10	07
73	PAINT	0.17	2.10	07
74	PAINT	0.17	2.10	07
75	PAINT	0.17	2.10	07
76	PAINT	0.17	2.10	07
77	PAINT	0.17	2.10	07
78	PAINT	0.17	2.10	07
79	PAINT	0.17	2.10	07
80	PAINT	0.17	2.10	07
81	PAINT	0.17	2.10	07
82	PAINT	0.17	2.10	07
83	PAINT	0.17	2.10	07
84	PAINT	0.17	2.10	07
85	PAINT	0.17	2.10	07
86	PAINT	0.17	2.10	07
87	PAINT	0.17	2.10	07
88	PAINT	0.17	2.10	07
89	PAINT	0.17	2.10	07
90	PAINT	0.17	2.10	07
91	PAINT	0.17	2.10	07
92	PAINT	0.17	2.10	07
93	PAINT	0.17	2.10	07
94	PAINT	0.17	2.10	07
95	PAINT	0.17	2.10	07
96	PAINT	0.17	2.10	07
97	PAINT	0.17	2.10	07
98	PAINT	0.17	2.10	07
99	PAINT	0.17	2.10	07
100	PAINT	0.17	2.10	07

UNBQA Table for Building - AA (AA)

FLOOR	Name	UNBQA (sq)	UNBQA (sq)	General Area	No. of Rooms	No. of Tenement
GROUND FLOOR	SPATIAL	281.04	281.04	281.04	11	1
Total		281.04	281.04	281.04	11	1

Name of Developer	Sri Chandra Shekhar Prasad
Location	West Koiribandh Jharia, P.S. Jharia, Dhanbad, Jharkhand
Plot No.	284
Block No.	1
Phase No.	1
Area of Plot	268.00 Sqm
Area of Building	383.53 Sqm
Area of Plinth	135.10 Sqm
Area of Ground Floor	135.10 Sqm
Area of First Floor	113.33 Sqm
Area of Second Floor	113.33 Sqm
Area of Terrace	113.33 Sqm
Area of Staircase	113.33 Sqm
Area of Lift	113.33 Sqm
Area of Other	113.33 Sqm
Area of Total	383.53 Sqm

COLOR INDEX

ABUTTING ROAD
 PROPOSED WORK (COVERAGE AREA)
 EXISTING (To be retained)
 EXISTING (To be demolished)

Color Index
 PARKING CALCULATION

Building Type	Plot No.	Plot Area
Office Building	1	12.00
Total Area		12.00

MARGIN DETAIL

Building Type	Plot No.	Front Margin	Rear Margin	Side Margin	Solid Margin
Office Building	1	2.54	1.51	1.01	1.04

FAR & Tenement Details (Table 4c-1)

Building	No. of Same Bldg.	Total Built Up Area (Sq.m)	Proposed FAR Area (Sq.m)	Total FAR Area (Sq.m)	Storey (No.)
AA (AA)	1	383.53	383.53	383.53	03
Total	1	383.53	383.53	383.53	03