

Proposal Basic Information	
Proposal File No.	MADA/BP/0051/2022
Owner Name	MD Meraj Khan
Khata No	18 (New 129)
Plot No	528 (New 1411)
Village Name	Jialgora
Use	Residential
SubUse	Bungalow/ Dwelling / Non Apartment

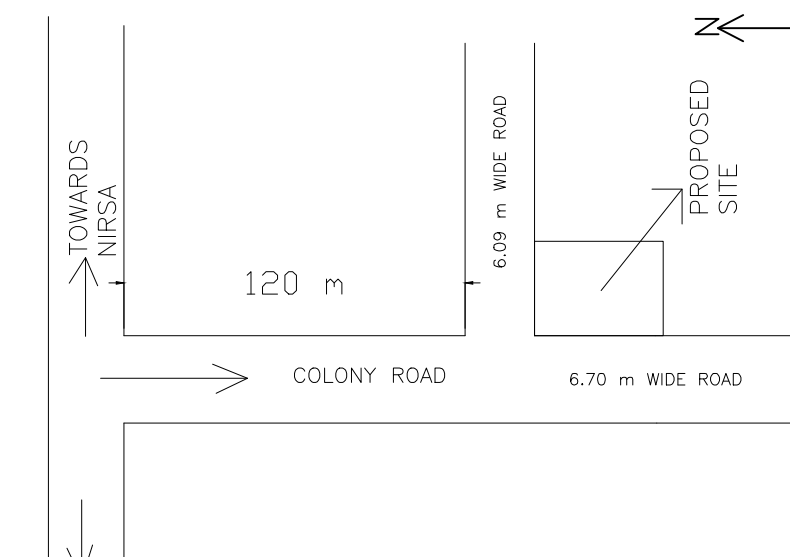
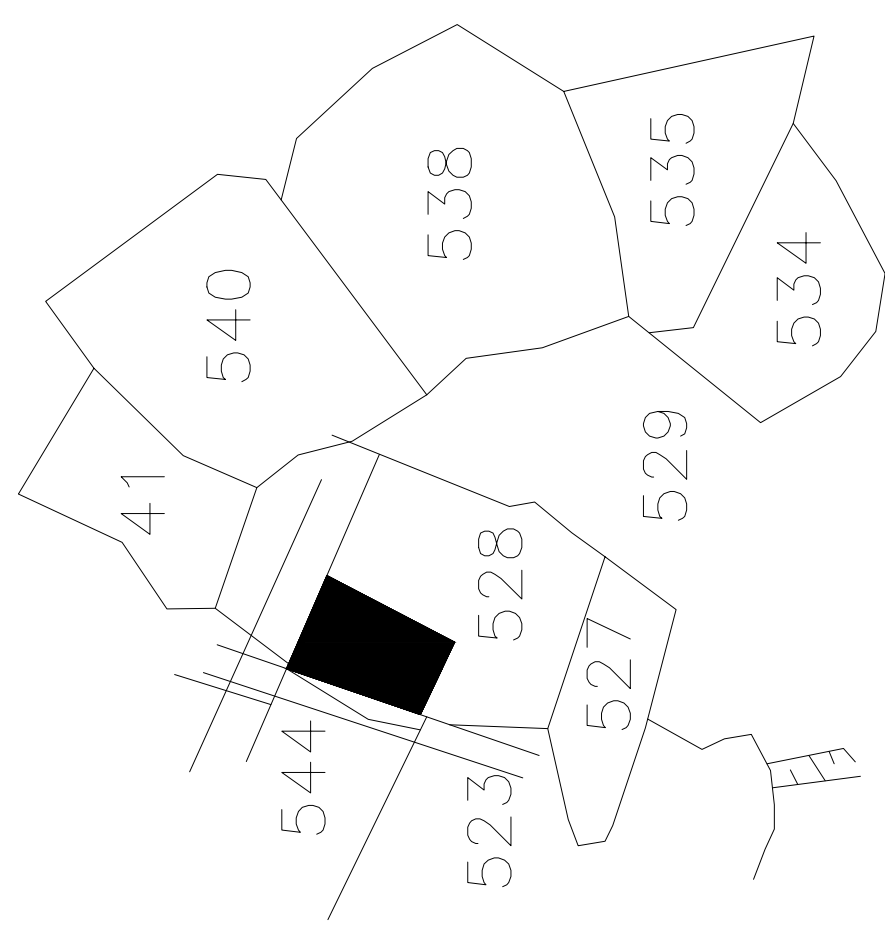
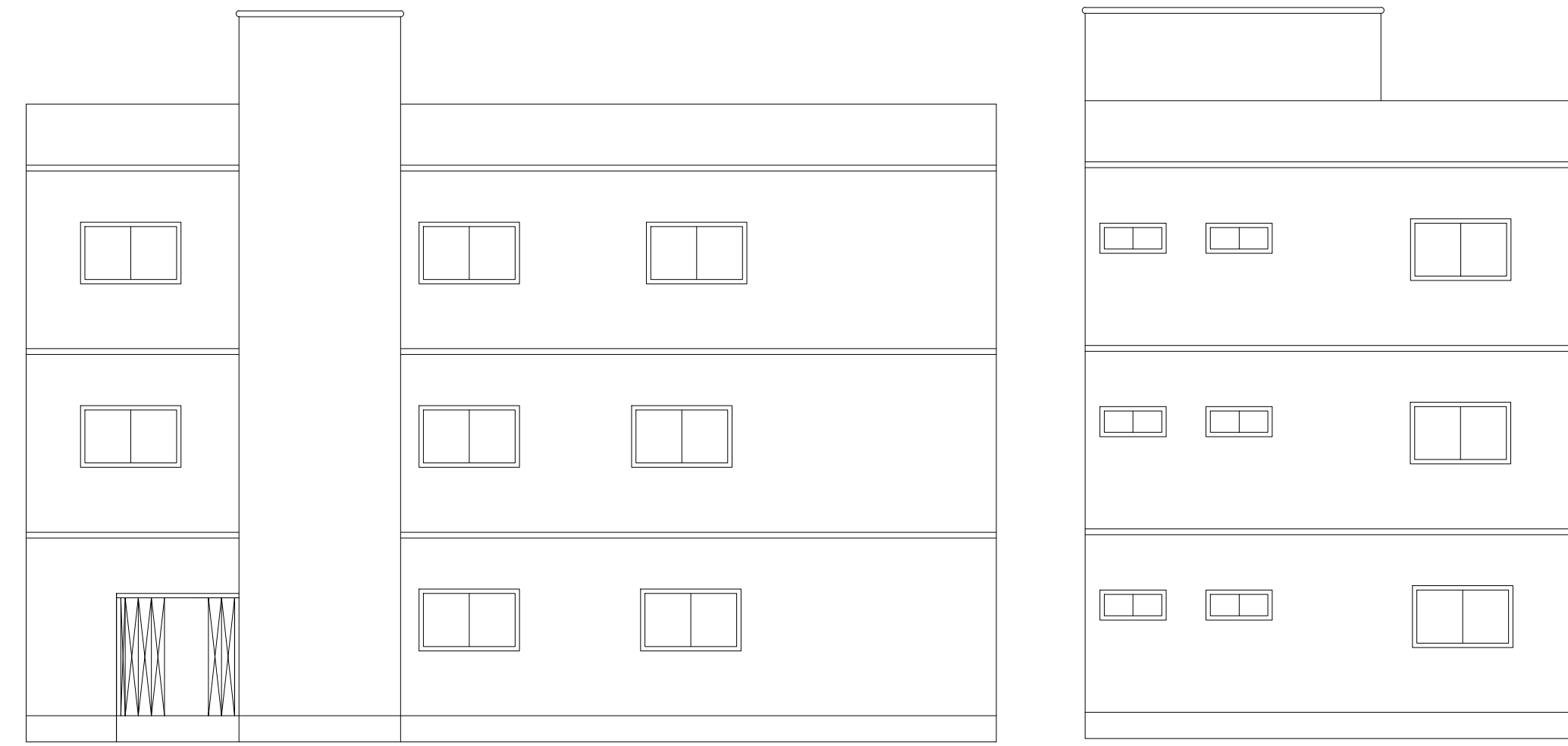
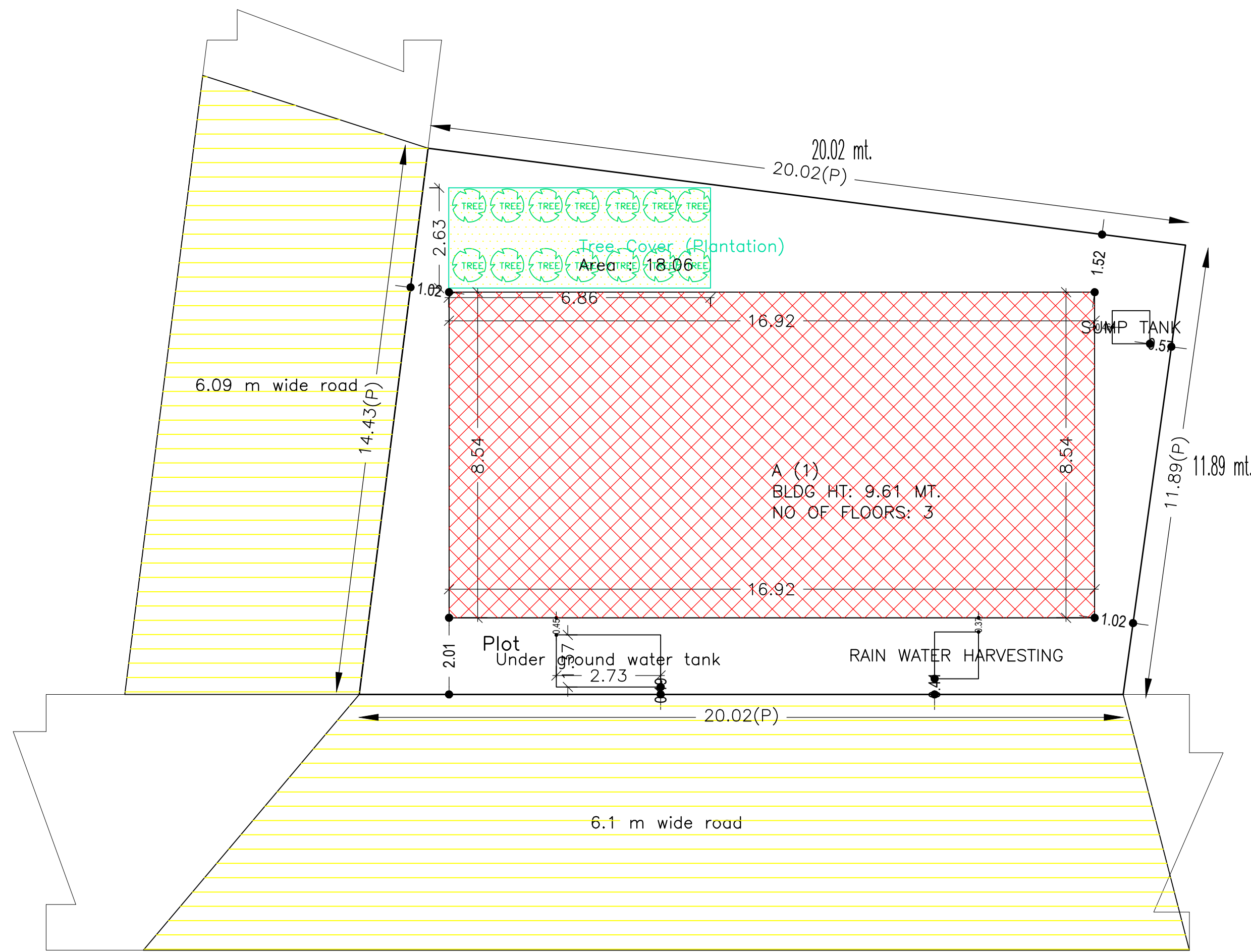

AREA STATEMENT MINERAL AREA DEVELOPMENT AUTHORITY		VERSION NO. : 1.0.62
PROJECT DETAIL:		VERSION DATE: 16/10/2020
Region: JHARKHAND URBAN LOCAL BODIES	Plot Use: Residential	
District: DHANBAD	Plot SubUse: Bungalow/ Dwelling / Non Apartment	
Authority: MINERAL AREA DEVELOPMENT AUTHORITY	PlotNearby/ReligiousStructure: NA	
Inward No: MADA/BP/0051/2022	Plot/SubPlot No: 528 (New 1411)	
Application Type: General Proposal	North: Road Width - 6.09	
Project Type: Building Permission	South: Plot No. - New 1411(p)	
Nature of Development: New	East: Plot No. - New 1411(p)	
Location of Development Area: Old Area	West: Road Width - 6.70	
AREA DETAILS:		SQ.MT.
AREA OF PLOT (Minimum)	(A)	262.39
NET AREA OF PLOT(Gross Plot Area - Deduction from Gross Plot area)	(A-Deductions)	262.39
Deduction for Balance Plot Area(from Gross Plot Area)		
Common Plot		18.06
Total		18.06
BALANCE AREA OF PLOT(Net Plot Area - Recreational/Amenity space)	(A-Deductions)	244.33
PLOT AREA FOR COVERAGE(Net Plot Area)	(A-Deductions)	262.39
Plot Area for FAR (Net Plot Area + RoadWidening Area)	(A-Deductions)	262.39
COVERAGE CHECK		
Permissible Coverage area (60.00 %)		157.43
Proposed Coverage Area (55.07 %)		144.50
Total Prop. Coverage Area (55.07 %)		144.50
Balance coverage area (4.93 %)		12.93
FAR CHECK		
Perm. FAR Area (2.50)		655.98
Total Perm. FAR area		655.98
Residential FAR		433.49
Proposed FAR Area		433.49
Total Proposed FAR Area		433.49
Consumed FAR (Factor)		1.65
Balance FAR Area		222.49
BUILT UP AREA CHECK		
Total Proposed BuiltUp Area		433.50
ARCHITECT (Regd)	Sushil Kumar	
ENGINEER (Regd)		
SUPERVISOR (Regd)		
OWNER (Regd)	MD Meraj Khan	
DEVELOPMENT AUTHORITY		LOCAL BODY

COLOR INDEX	
PLOT BOUNDARY	Black
ABUTTING ROAD	Green
PROPOSED CONSTRUCTION	Red
COMMON PLOT	Yellow
ROAD WIDENING AREA	Blue
EXISTING (To be retained)	Light Blue
EXISTING (To be demolished)	Orange

Floor Name	Building Name A (1)		Total	
	Proposed Built Up Area (Sq.mt.)	Proposed FAR Area (Sq.mt.)	Total Proposed Built Up Area (Sq.mt.)	Total FAR Area (Sq.mt.)
Ground Floor	144.50	144.50	144.50	144.50
First Floor	144.50	144.50	144.50	144.50
Second Floor	144.50	144.50	144.50	144.50
Terrace Floor	0.00	0.00	0.00	0.00
Total:	433.50	433.50	433.50	433.50

Building Name	Building Use	Building SubUse	Building Structure
A (1)	Residential	Residential Bldg/Apartment	Non-Highrise

FLOOR	Name	UnitBUA Type	UnitBUA Area	Carpet Area	No. of Rooms	No. of Tenement
GROUND FLOOR PLAN	SPLIT 1	FLAT	433.49	433.43	7	1
FIRST FLOOR PLAN	SPLIT 1	FLAT	0.00	0.00	9	0
SECOND FLOOR PLAN	SPLIT 1	FLAT	0.00	0.00	9	0
Total:	-	-	433.49	433.43	25	1

Building	No. of Same Bldg	Total Built Up Area (Sq.mt.)	Proposed FAR Area (Sq.mt.) Resi.	Total FAR Area (Sq.mt.)	Total Consumed Additional FAR Area (Sq.mt.)	Tnmt (No.)
A (1)	1	433.50	433.50	433.50	433.50	01
Grand Total :	1	433.50	433.50	433.50	433.50	01

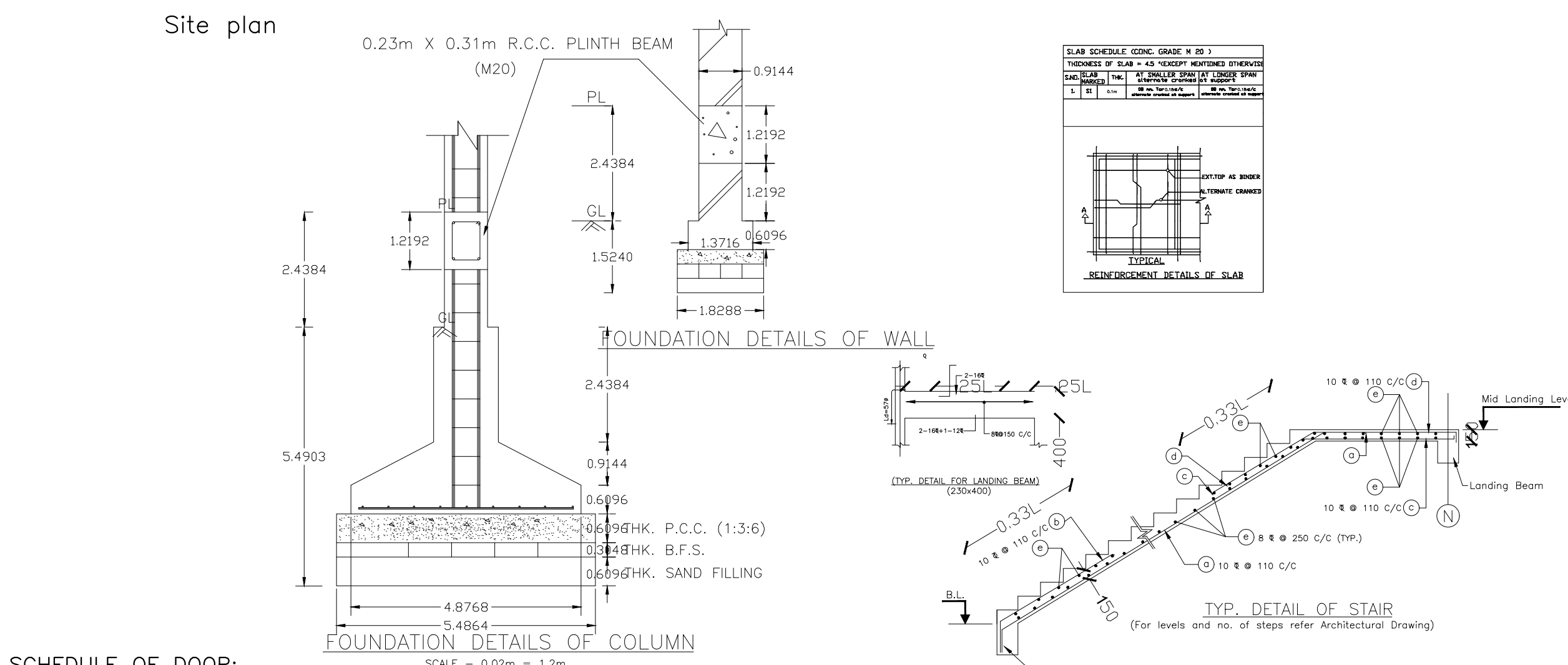

SCHEDULE OF DOOR:

BUILDING NAME	NAME	LENGTH	HEIGHT	NOS
A (1)	d2	0.91	2.10	15
A (1)	D1	1.22	2.10	06
A (1)	D	1.22	2.10	01
A (1)	SD	1.37	2.10	02
A (1)	C.G.	2.13	2.10	01

SCHEDULE OF WINDOW/VENTILATION:

BUILDING NAME	NAME	LENGTH	HEIGHT	NOS
A (1)	V1	0.65	0.60	10
A (1)	W1	1.80	1.20	22
A (1)	W	6.94	2.13	01

Building :A (1)

Floor Name	Total Built Up Area (Sq.mt.)	Proposed FAR Area (Sq.mt.) Resi.	Total FAR Area (Sq.mt.)	Total Consumed Additional FAR Area (Sq.mt.)	Tnmt (No.)
Ground Floor	144.50	144.50	144.50	144.50	01
First Floor	144.50	144.50	144.50	144.50	00
Second Floor	144.50	144.50	144.50	144.50	00
Terrace Floor	0.00	0.00	0.00	0.00	00
Total :	433.50	433.50	433.50	433.50	01
Total Number of Same Buildings :	1				
Total :	433.50	433.50	433.50	433.50	01

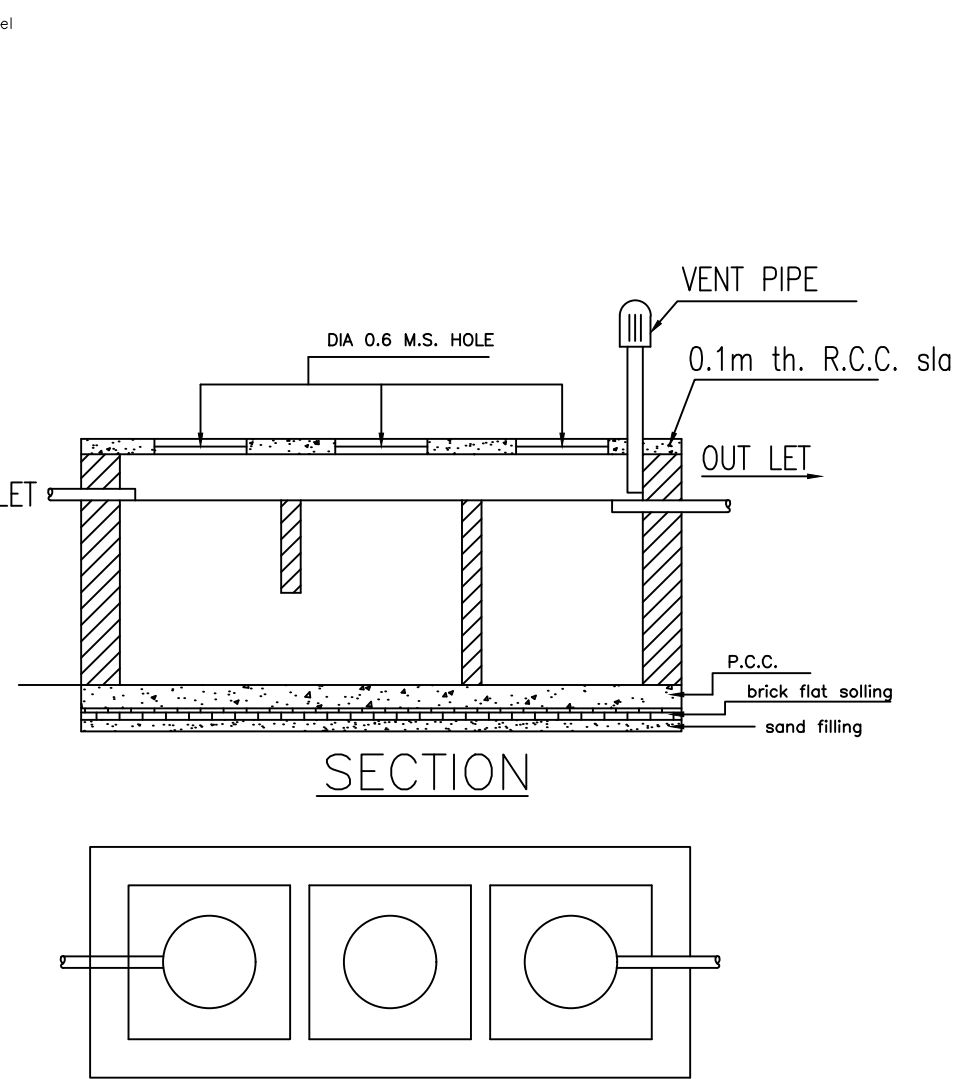

DETAILS OF SEPTIC TANK

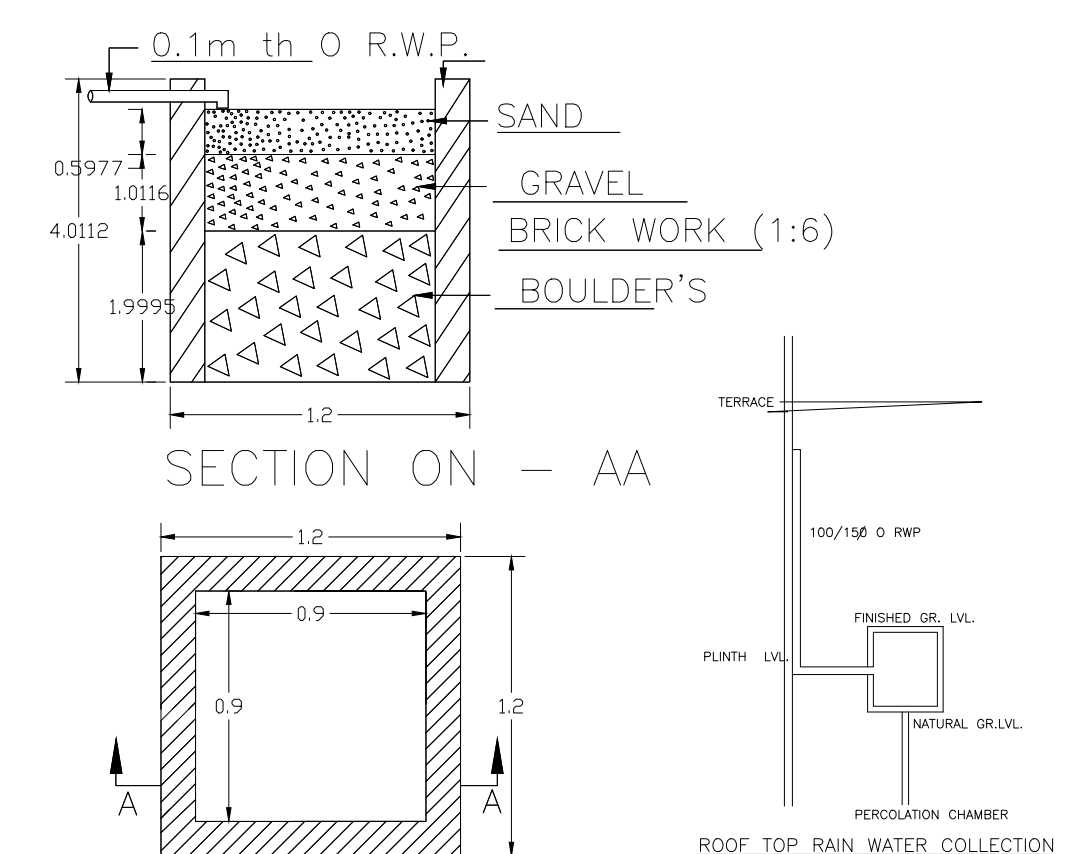

DETAIL'S OF WATER HARVESTING

LTP NAME AND SIGNATURE	STRUCTURAL ENG'S NAME AND SIGNATURE	BUILDER NAME AND SIGNATURE	DIGITAL SIGNATURE
Sushil Kumar MADA/ENG/0009/2019			

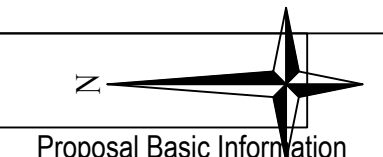

Proposal Basic Information

Proposal File No.	MADA/BP/0051/2022
Owner Name	MD Meraj Khan
Khata No	18 (New 129)
Plot No	528 (New 1411)
Village Name	Jialgora
Use	Residential
SubUse	Bungalow/ Dwelling / Non Apartment

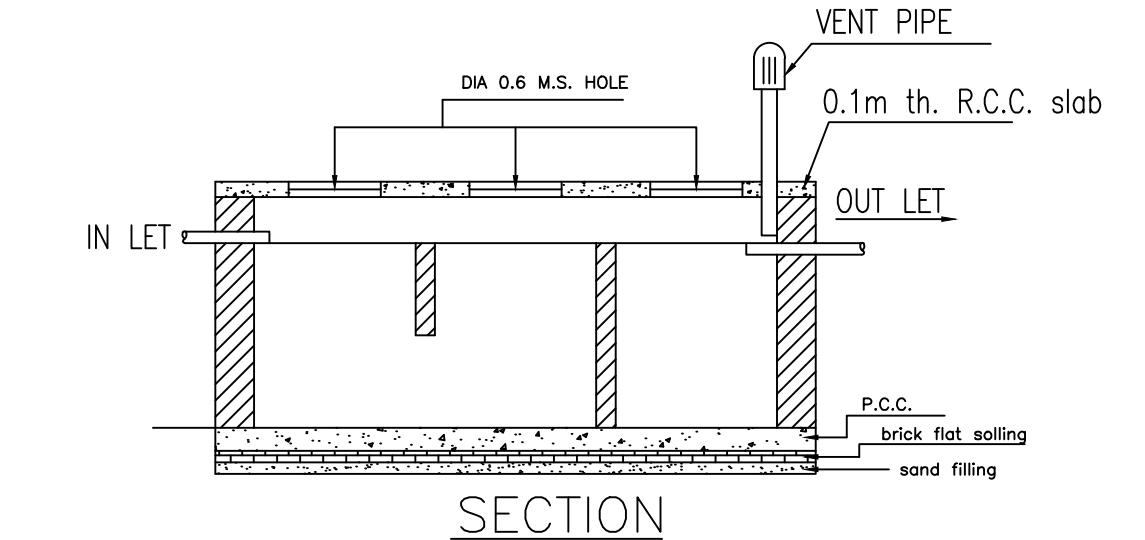
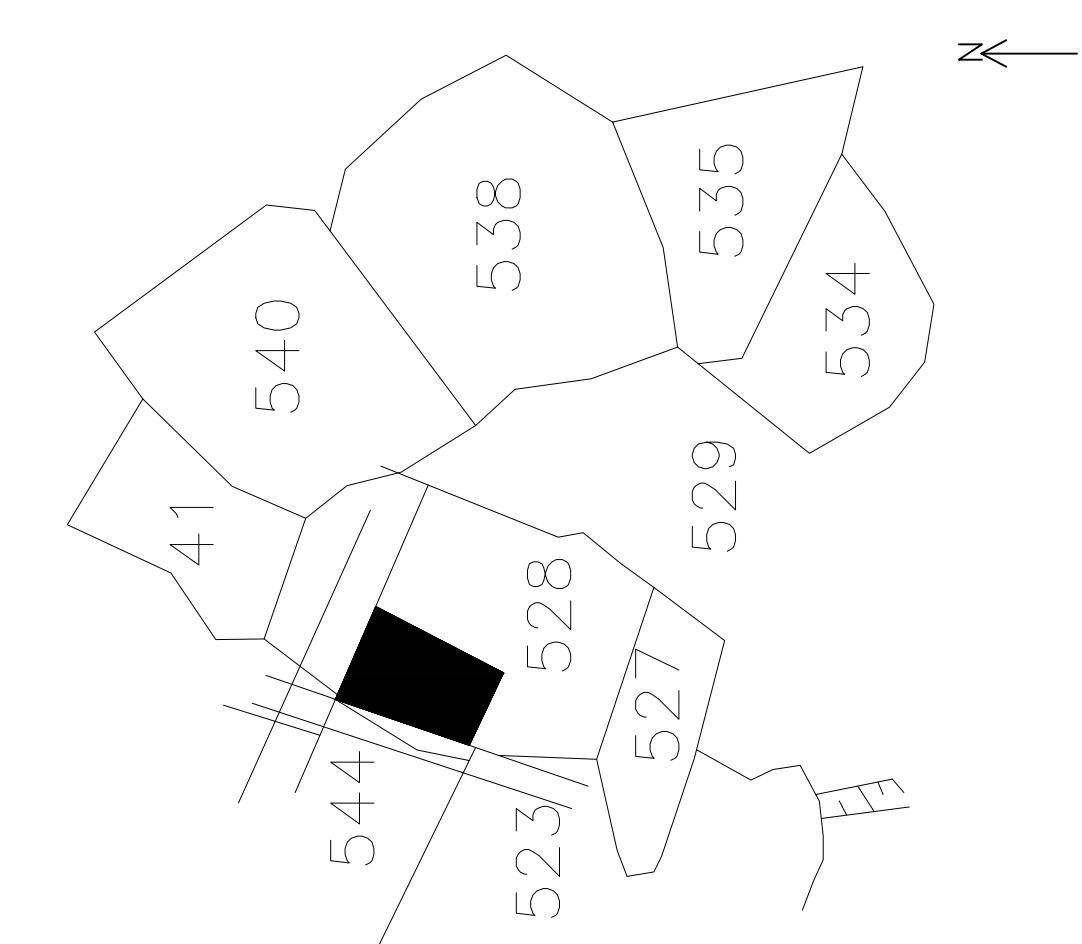
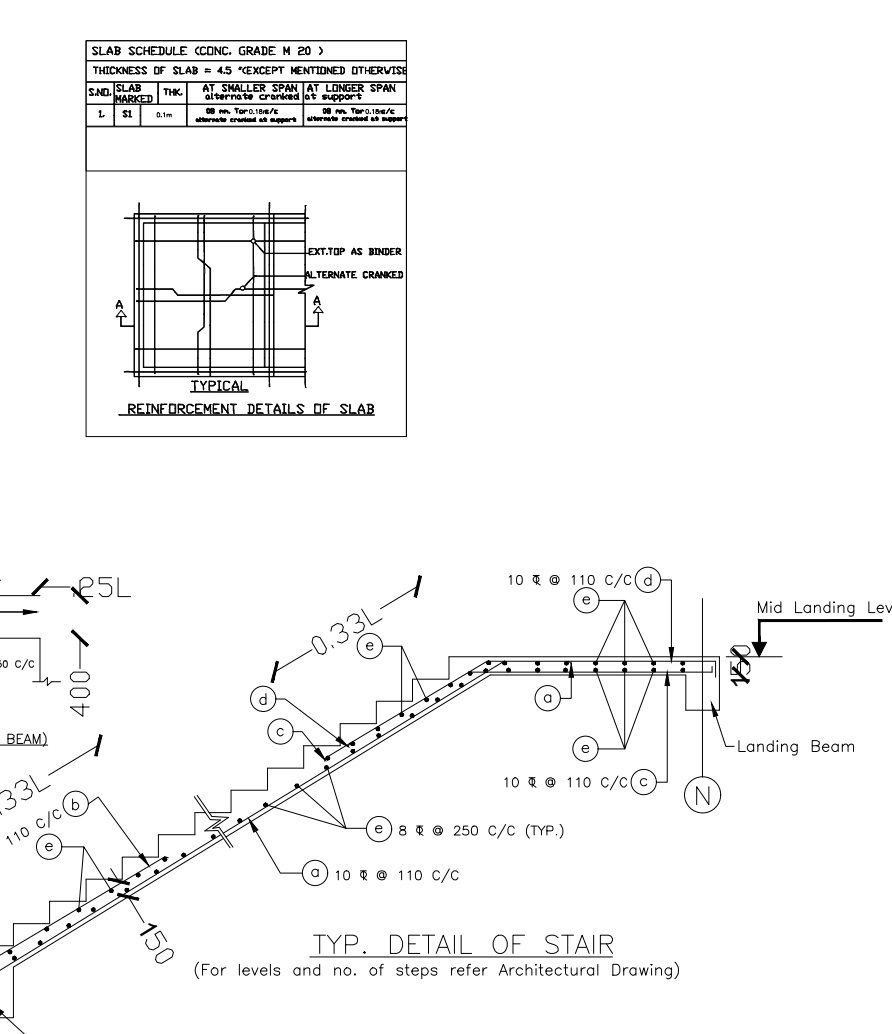
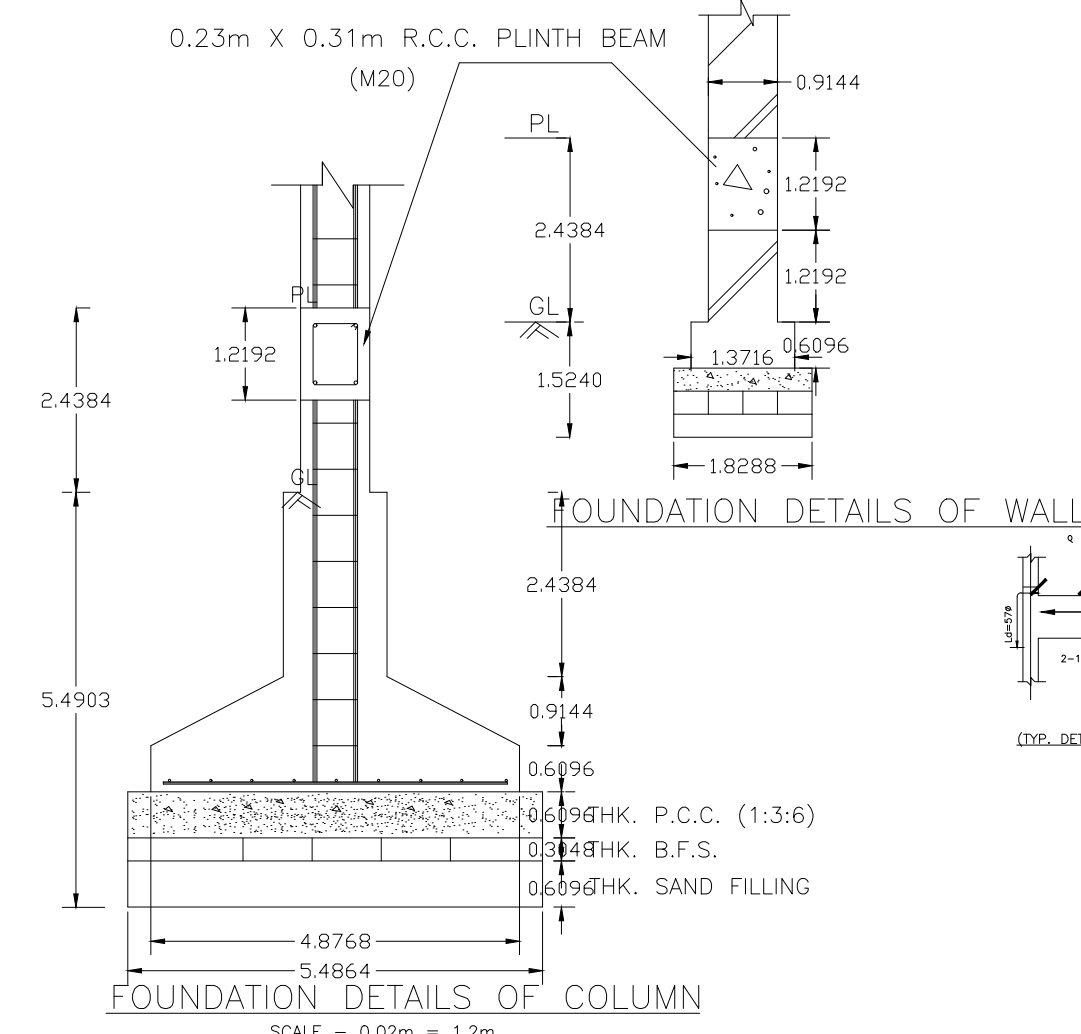
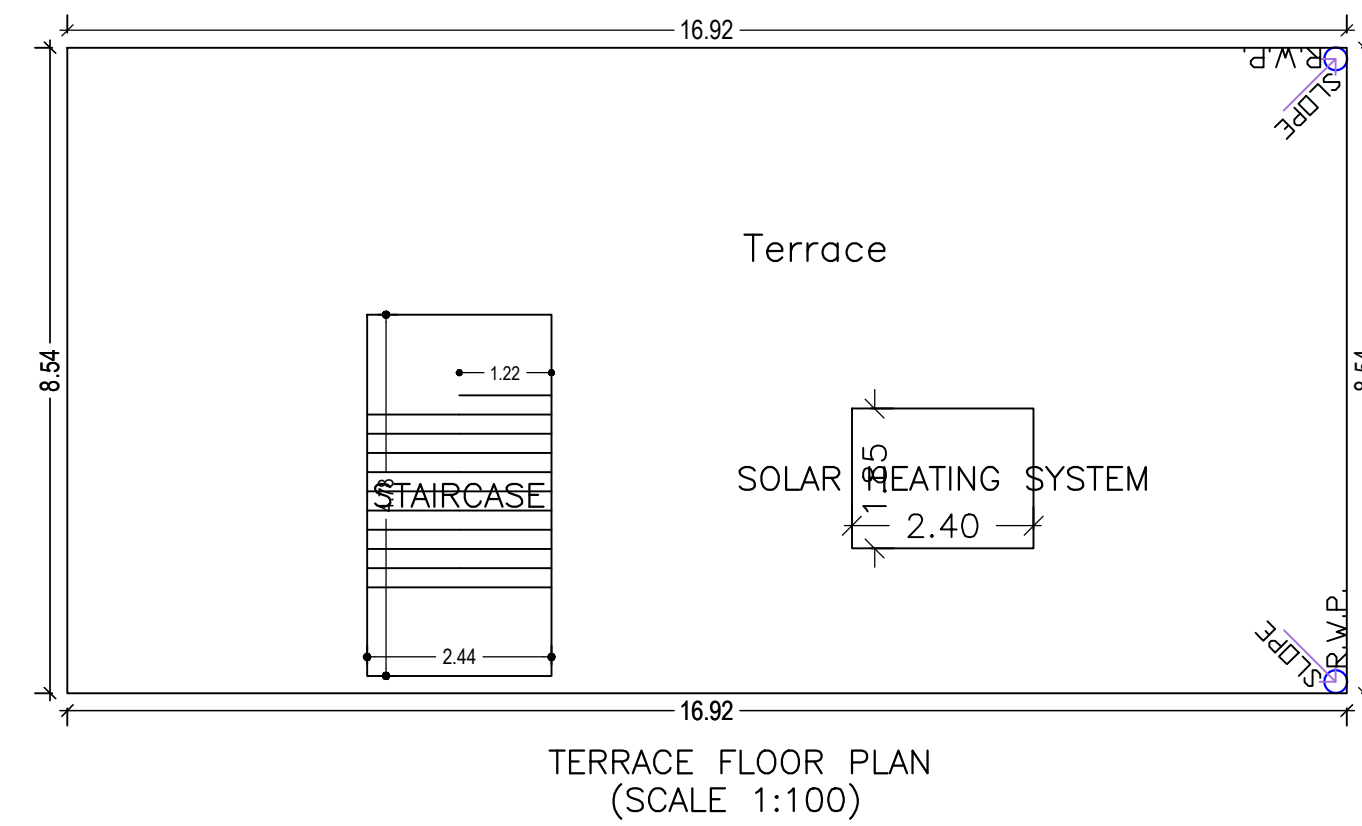
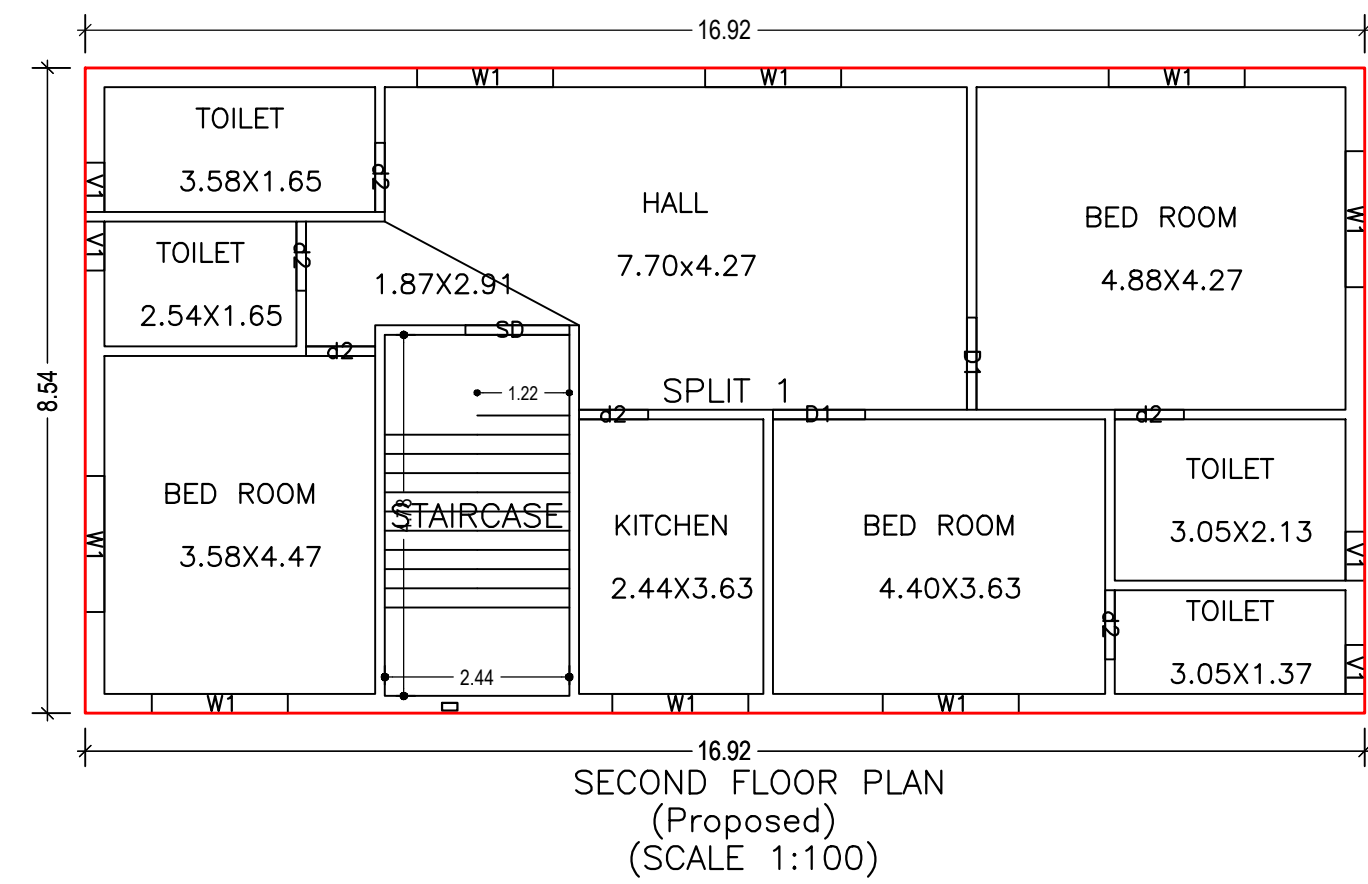
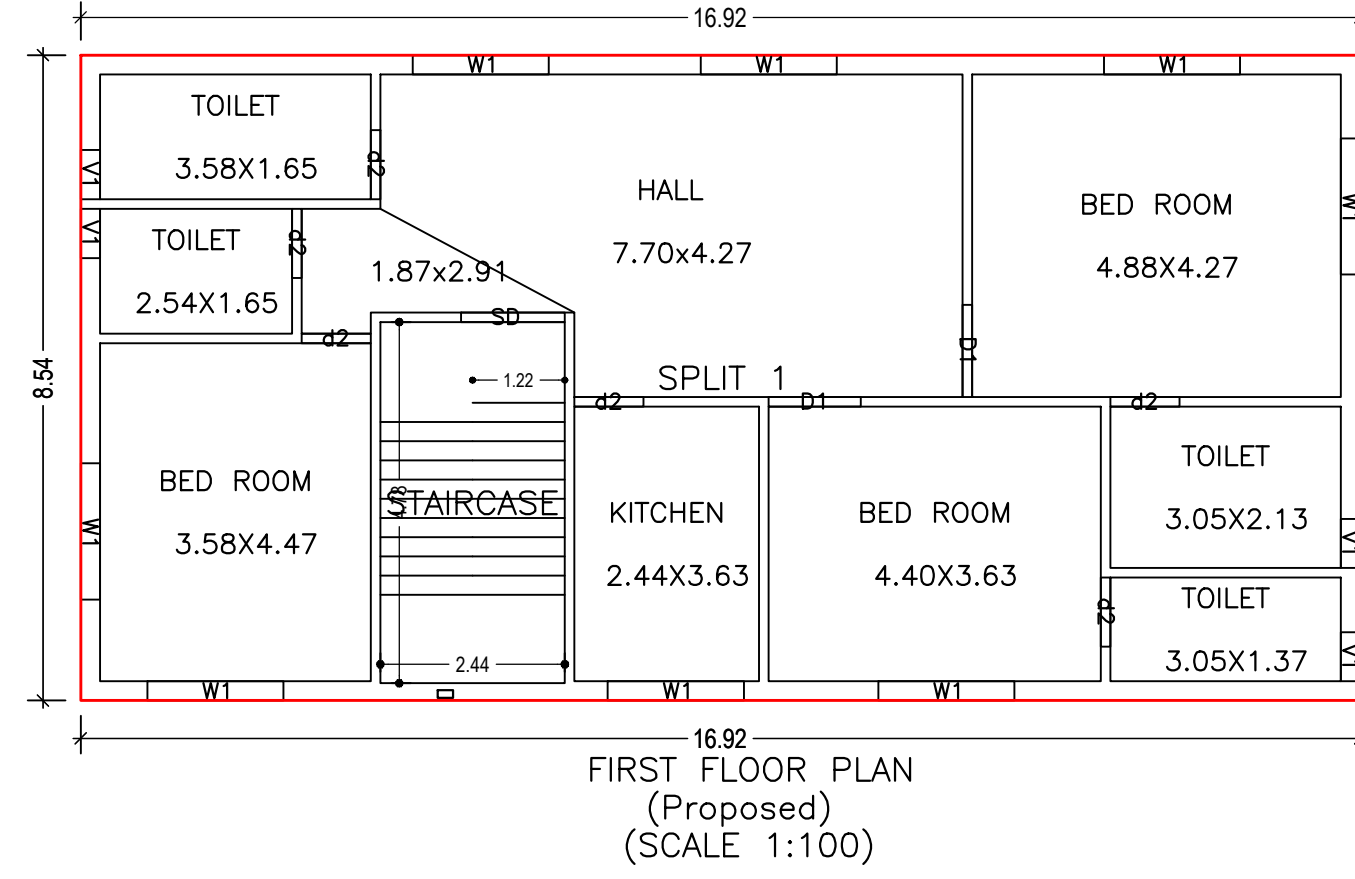
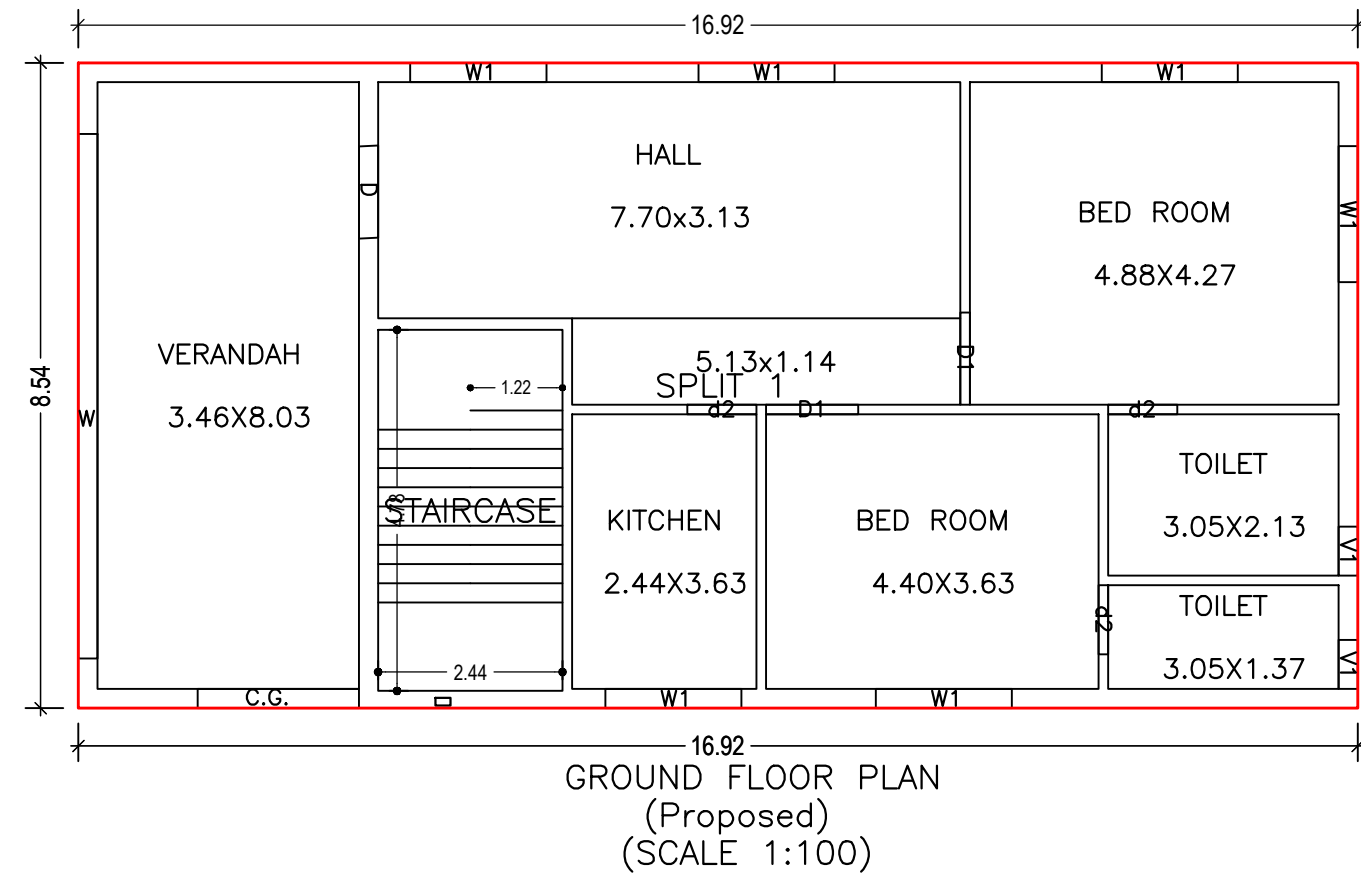

DETAILS OF SEPTIC TANK

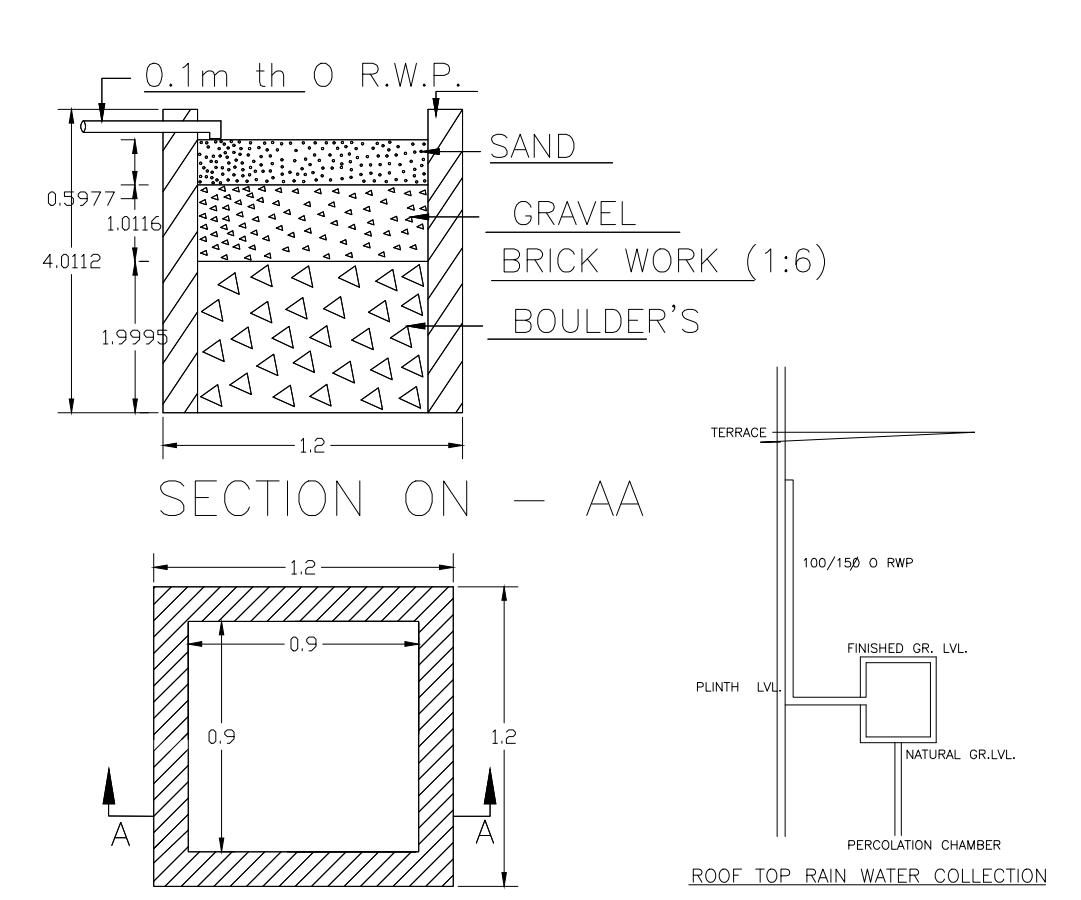
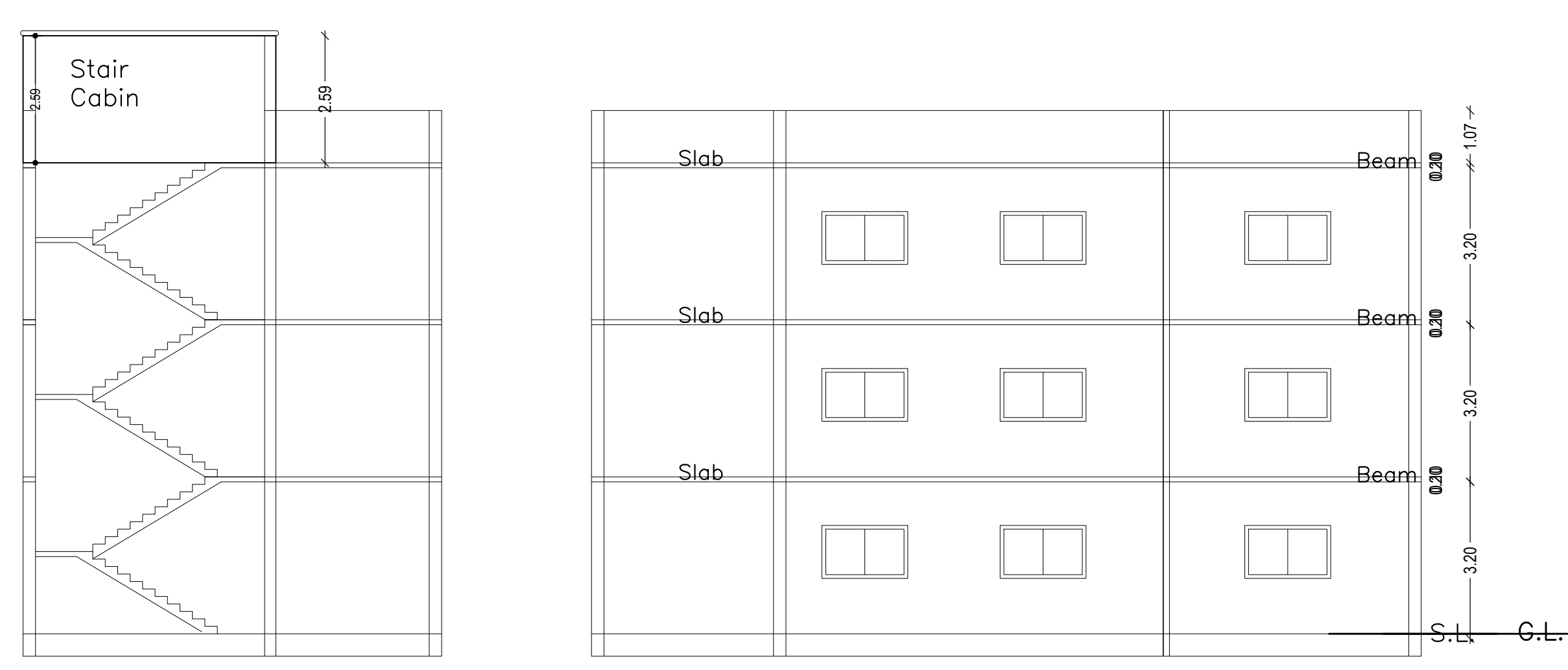
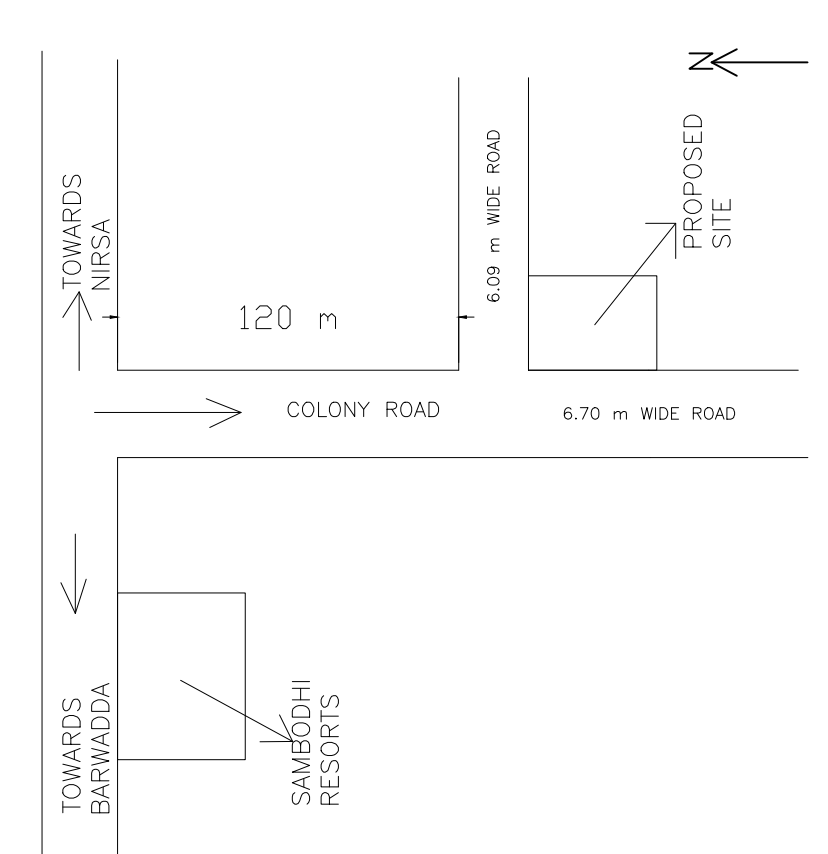

LTP NAME AND SIGNATURE	STRUCTURAL ENG'S NAME AND SIGNATURE	BUILDER NAME AND SIGNATURE	DIGITAL SIGNATURE
Sushil Kumar MADA/ENG/0009/2019			