

Project Title :SRI BIPLAB KUMAR PAUL

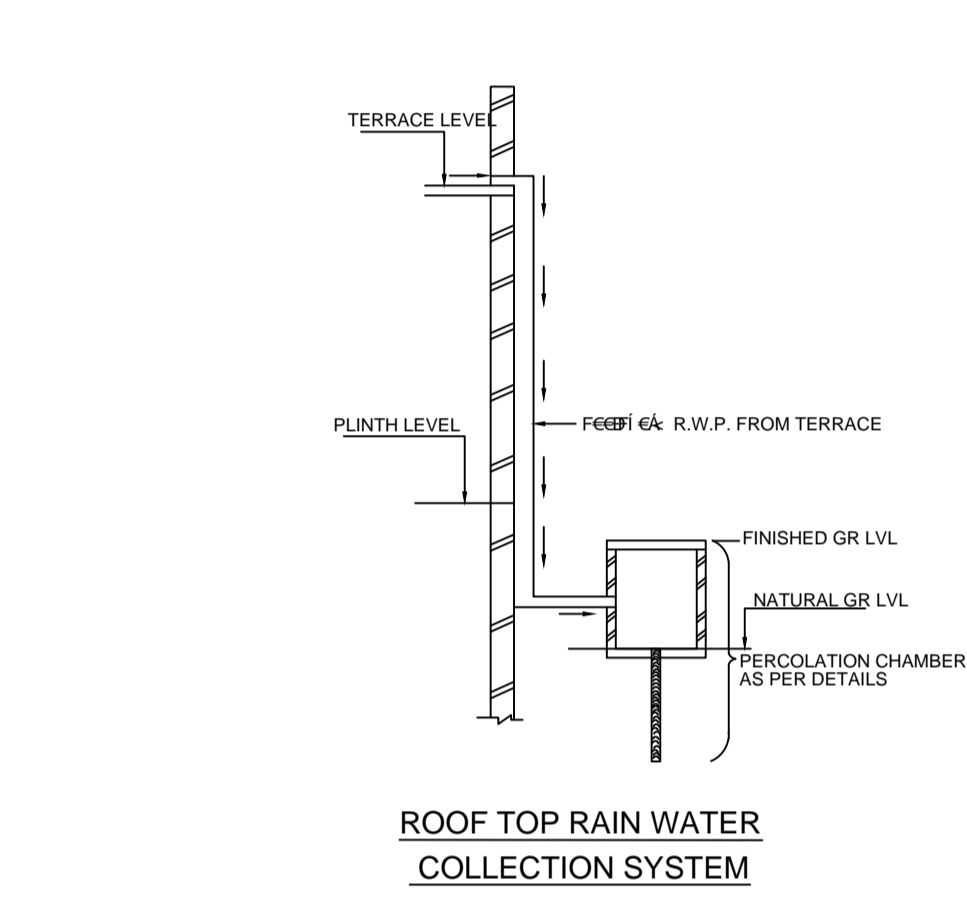
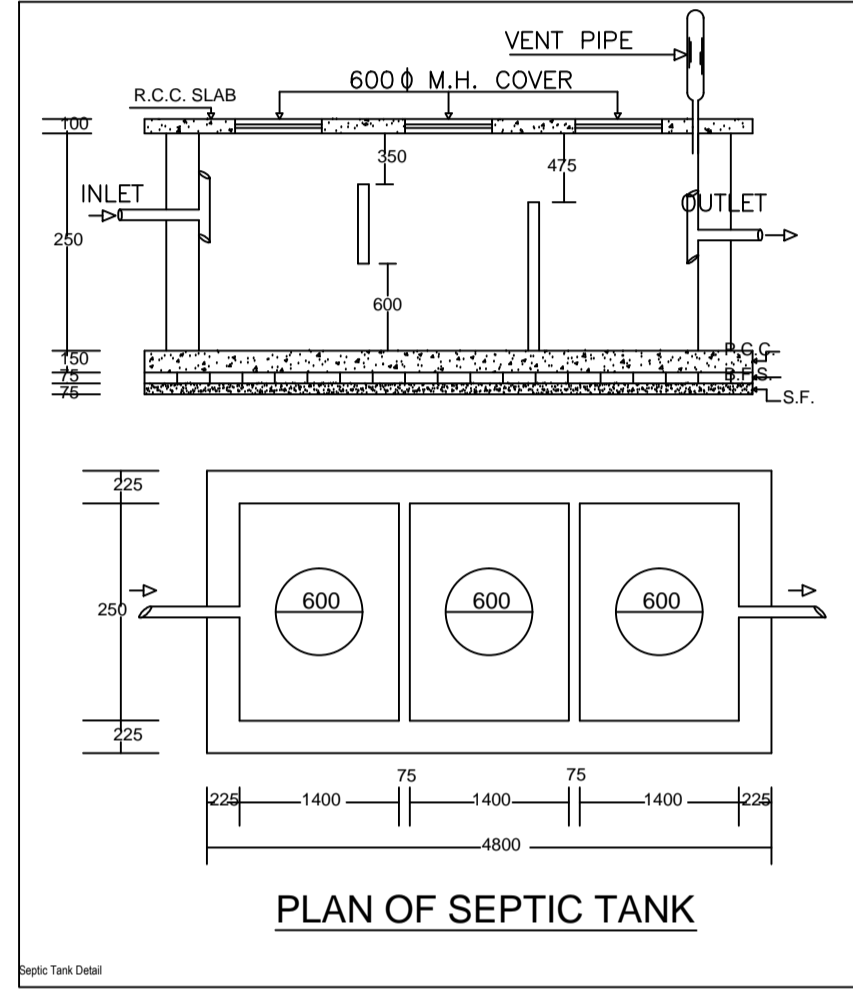
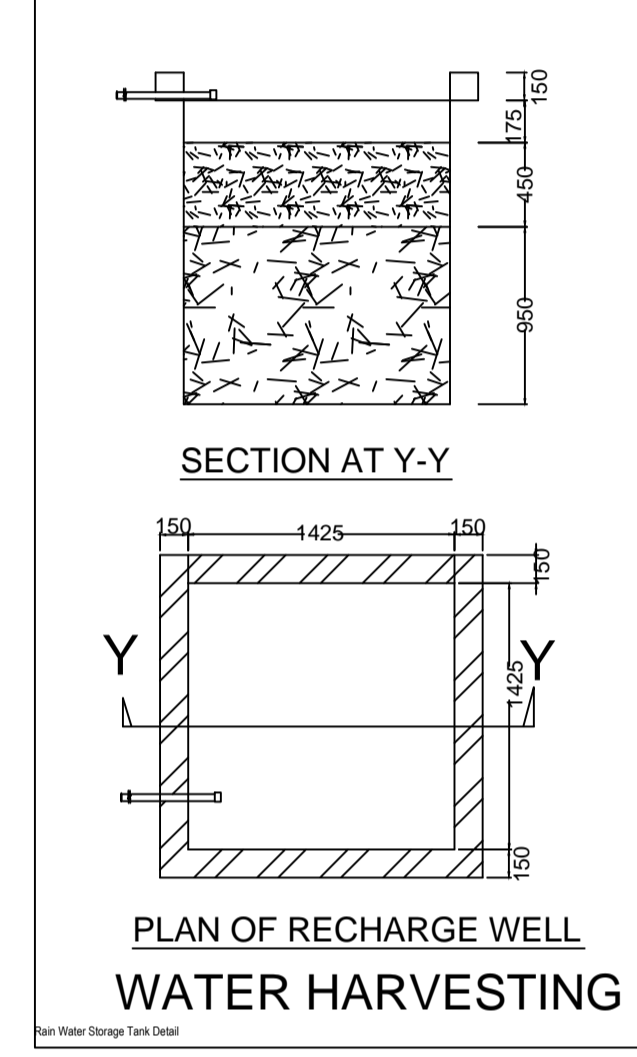
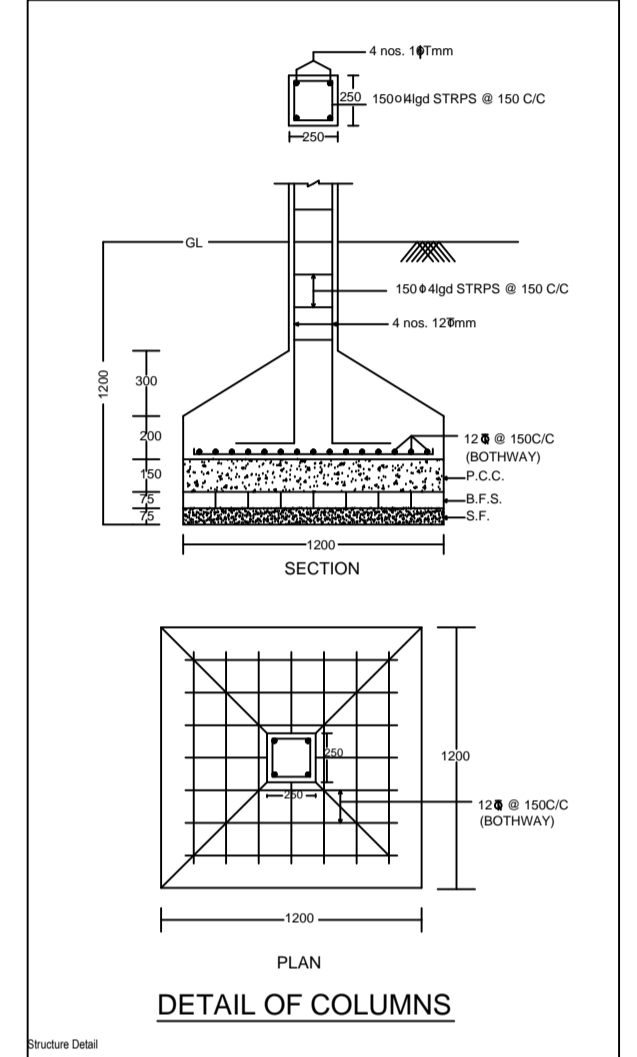
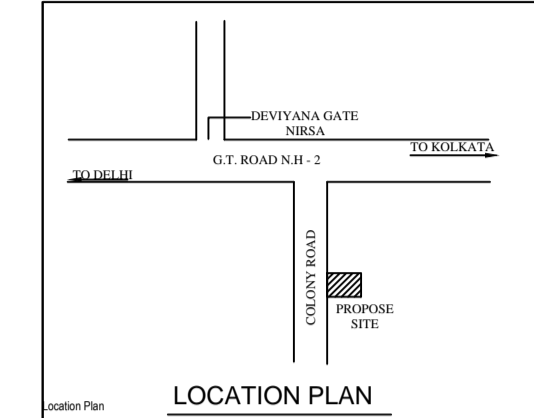
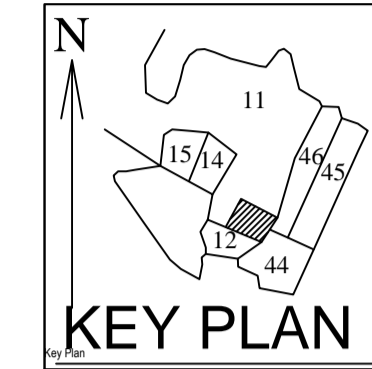
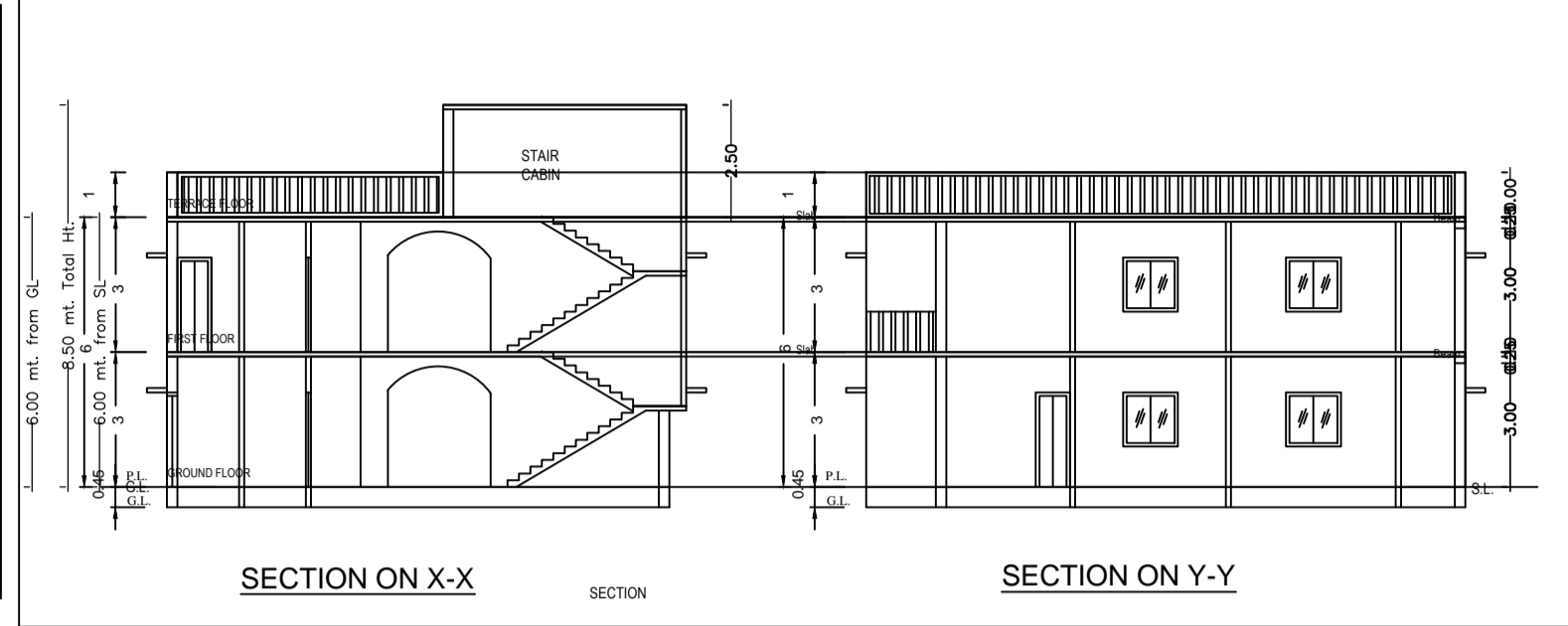
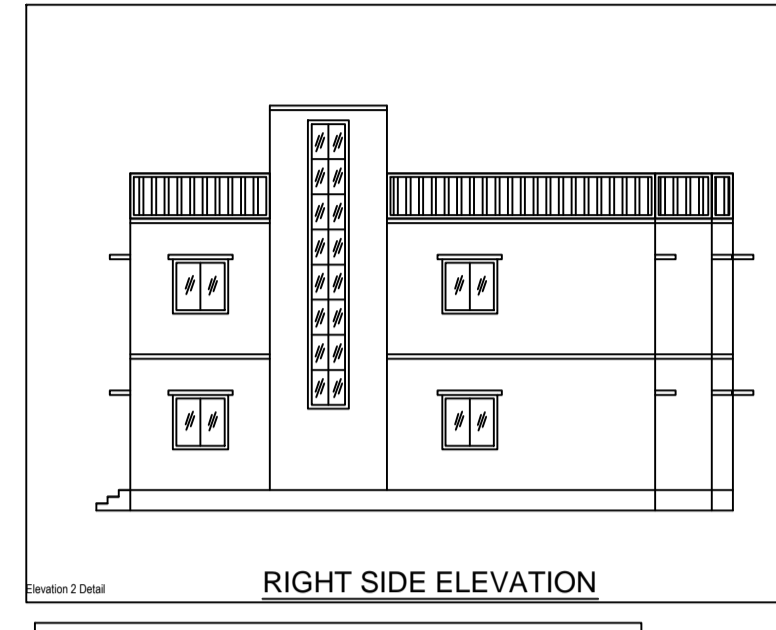
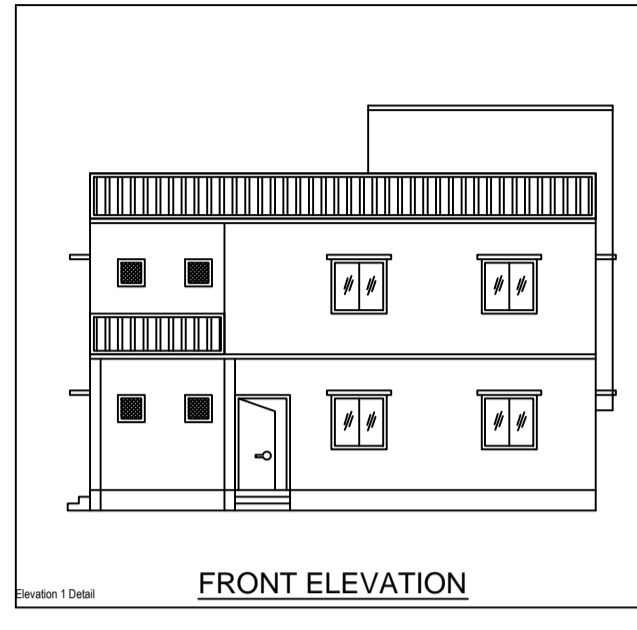
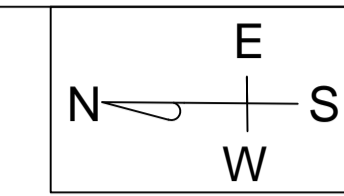

BRIEF SPECIFICATION

FOUNDATION----- CEMENT CONCRETE (1:1.5:3)
 BRICK WORK IN FOUNDATION & SUPERSTRUCTURE
 FIRST CLASS BRICK WORK IN CEMENT MORTAR (1:6)
 D.P.C.-----25 D.P.C. IN CEMENT CONCRETE (1:2:4)
 FLOOR-----25 I.P.S. OVER 75 P.C.C.
 ROOF-----100 THK. R.C.C. ROOF (1:1.5:3)
 LINTEL-----150 THK. R.C.C. LINTEL (1:1.5:3)
 STAIRS-----RISE-- 150, TREAD-- 250

DETAILS OF AREA

TOTAL LAND AREA (AS PER DEED) ---	273.26 SQM.
TOTAL LAND AREA (AS PER SITE) ---	251.90 SQM.
GROUND FLOOR AREA-----	142.94 SQM.
FIRST FLOOR AREA-----	142.94 SQM.
TOTAL COVERED AREA-----	285.88 SQM.
% PLINTH AREA-----	56.74 %
FAR -----	1.13

SCHEDULE

D = 1.200X2.100	W = 1.500X1.200
D1 = 1.050X2.100	W1 = 1.200X1.200
D2 = 0.900X2.100	V = 0.600X0.600
D3 = 0.750X2.100	

TITLE OF DRAWING
 PLAN OF PROPOSED RESIDENTIAL BUILDING OF- SRI BIPLAB KUMAR PAUL , SO.- LATE NIMAI CHANDRA PAUL, OF SINDRI COLONY,(BEFW) , P.S.- NIRSA, DIST.- DHANBAD, UNDER MOUZA - HATIBARI , NO.- 19, KHATA NO.-31, NEW KHATA NO. - 78 PLOT NO.-11, NEW PLOT NO.- 10, 34 IN THE DISTT. OF DHANBAD (JHARKHAND).

SIGNATURE OF OWNER

SIGNATURE OF ENGINEER

SCALE

ALL DIMENSION ARE IN METRE

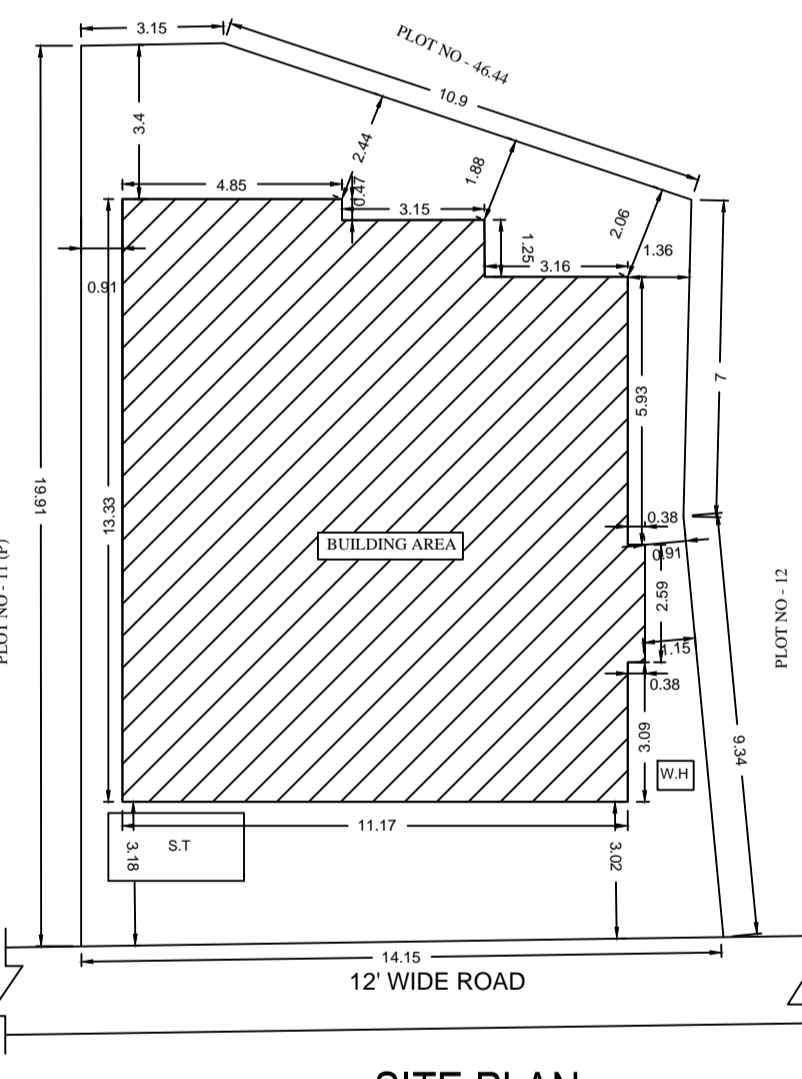
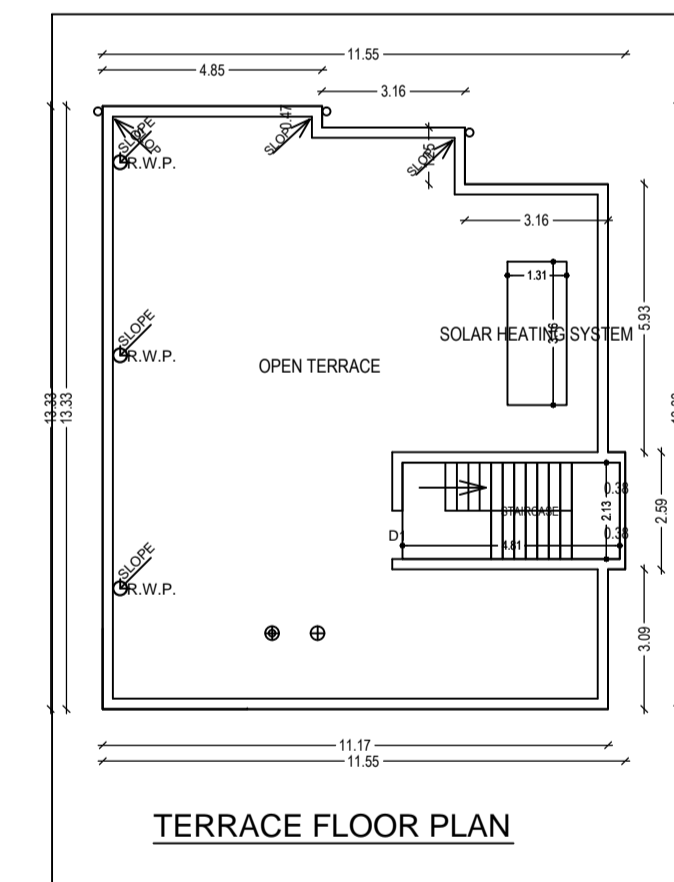
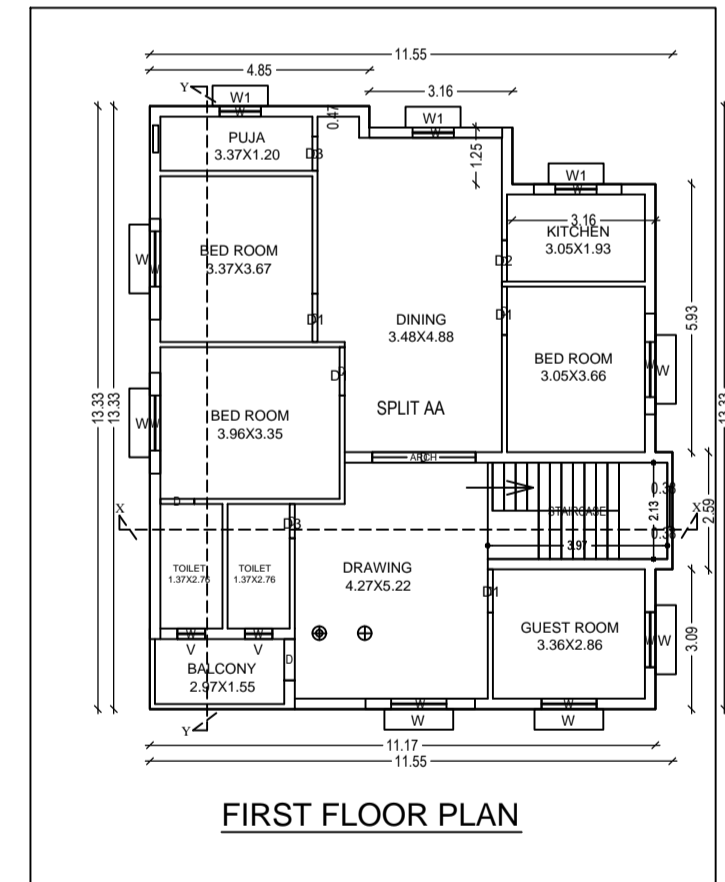
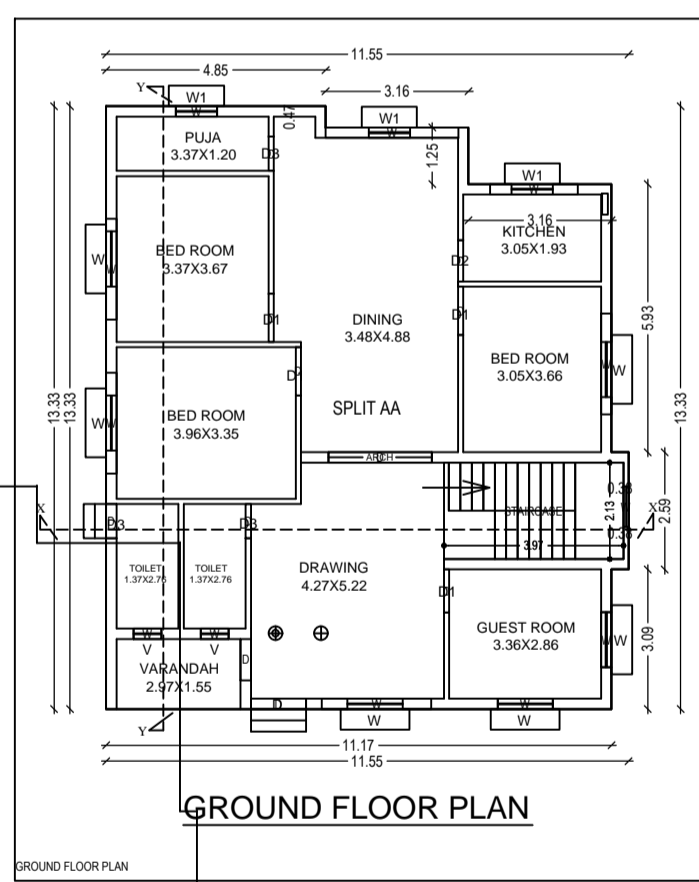
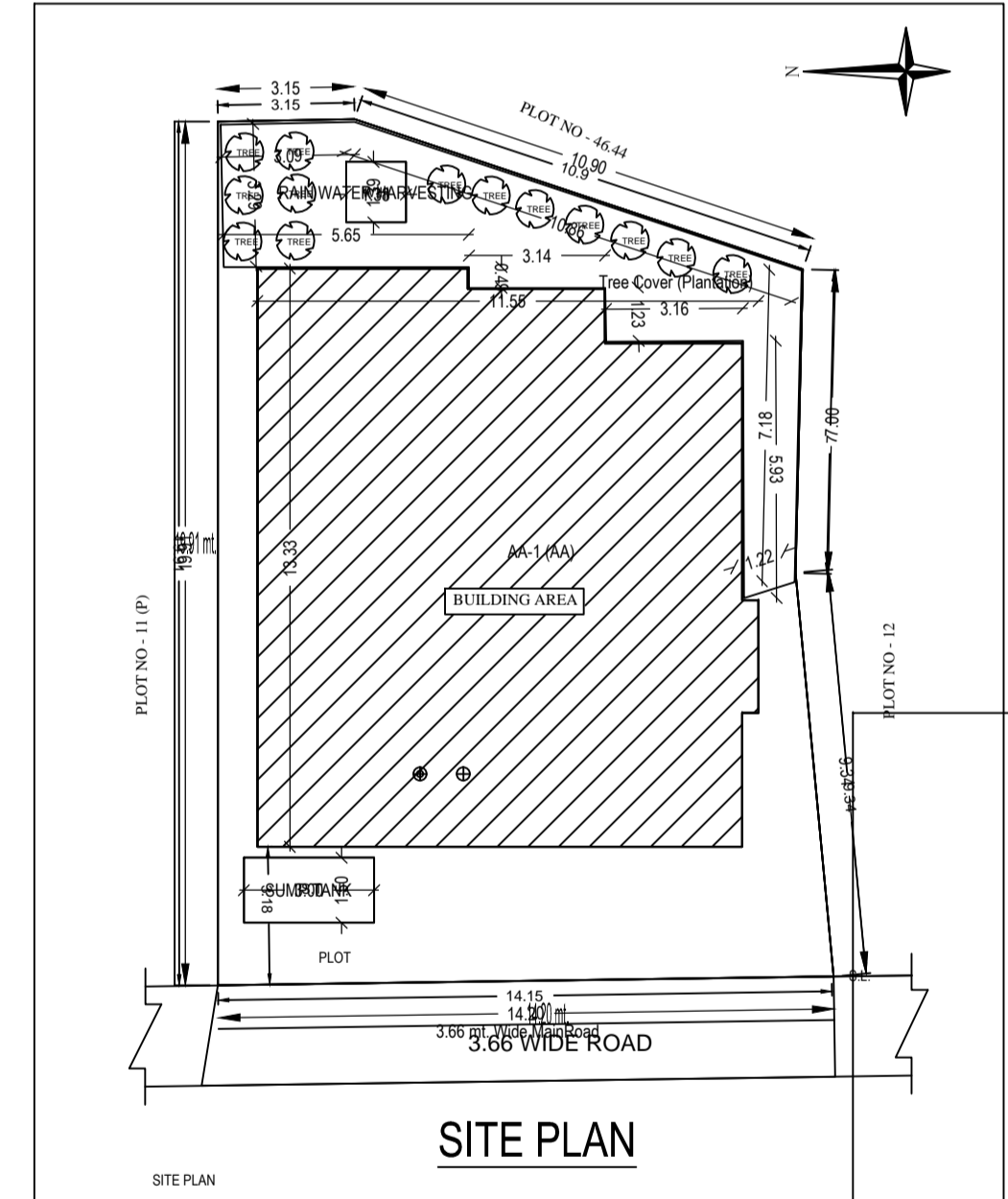

Building: AA (AA)

Floor Name	Total Built Up Area (Sq.Mt.)	Proposed FAR Area (Sq.Mt.)	Total FAR Area (Sq.Mt.)	Tonn (No.)
Ground Floor	142.94	142.94	142.94	01
First Floor	142.94	142.94	142.94	02
Terrace Floor	0.00	0.00	0.00	00
Total	285.88	285.88	285.88	01

SCHEDULE OF JOINERY:

BUILDING NAME	NAME	LENGTH	HEIGHT	NO.
AA (AA)	D	0.70	2.10	02
AA (AA)	D	0.70	2.10	02
AA (AA)	D	0.91	2.10	04
AA (AA)	D	0.90	2.10	02
AA (AA)	D	1.07	2.10	06
AA (AA)	D	1.22	2.10	02
AA (AA)	D	2.20	2.10	02
Total	-	-	-	21

SCHEDULE OF JOINERY:

BUILDING NAME	NAME	LENGTH	HEIGHT	NO.
AA (AA)	W	0.61	1.20	02
AA (AA)	W	0.90	1.20	01
AA (AA)	W	0.91	1.20	02
AA (AA)	W	1.22	1.20	04
AA (AA)	W	1.06	1.20	02
AA (AA)	W	2.21	1.20	02
AA (AA)	W	2.42	1.20	02
AA (AA)	W	2.93	1.20	02
Total	-	-	-	23

UrbBUA Table for Building: AA (AA)

FLOOR	Name	UrbBUA Type	UrbBUA Area	Carpet Area	No. of Rooms	No. of Tenement
GROUND FLOOR PLAN	SPLIT AA	FLAT	285.88	285.75	11	1
Total	-	-	285.88	285.75	22	1

AREA STATEMENT: MINERAL AREA DEVELOPMENT

Authority	Version No.
PROJECT DETAIL	VERSION DATE: 16/10/2020
Plot No. - Residential	
Plot Size/Block - Bangalore/Coastal - Non Apartment	
Land Use Zone - Residential	
Project Type - Building/Proposed	
Revenue Survey No/Survey No -	
Location - 10A	
Block No. -	
Village/Moza Name -	
Phase No. -	
Section -	
Block -	
Plot -	

COLOR INDEX

Color	Symbol
PROPOSED WORK (COVERAGE AREA)	Diagonal Lines
EXISTING WORK (COVERAGE AREA)	Horizontal Lines
EXISTING (To be retained)	Vertical Lines
EXISTING (To be removed)	Stippled

Color Index:

Building / Plot No.	Road Name	Front Margin	Rear Margin	Side1 Margin	Side2 Margin
AA (AA)	1.00 M. Wide	3.02	1.88	0.91	0.91

FAR & Tenement Details (Table 4c-1)

Building	No. of Same Bldg	Total Built Up Area (Sq.Mt.)	Proposed FAR Area (Sq.Mt.)	Total FAR Area (Sq.Mt.)	Tonn (No.)
AA (AA)	1	285.88	285.88	285.88	01
Grand Total	1	285.88	285.88	285.88	01