

Proposal Basic Information

Proposal File No.	MADA/BP/0364/2022
Owner Name	SMT. SABITA SHARMA
Khata No	OLD KHATA NO- 69, NEW KHATA NO-134
Plot No	OLD PLOT NO- 517, NEW PLOT NO-1456
Village Name	Jialgora
Use	Residential
SubUse	Bungalow/ Dwelling / Non Apartment

AREA STATEMENT MINERAL AREA DEVELOPMENT AUTHORITY	VERSION NO.: 1.0.64 VERSION DATE: 16/10/2020
PROJECT DETAIL:	
Region: JHARKHAND URBAN LOCAL BODIES	Plot Use: Residential
District: DHANBAD	Plot SubUse: Bungalow/ Dwelling / Non Apartment
Authority: MINERAL AREA DEVELOPMENT AUTHORITY	PlotNearby/ReligiousStructure: NA
Inward_No: MADA/BP/0364/2022	Plot/SubPlot No: OLD PLOT NO- 517, NEW PLOT NO-1456
Application Type: General Proposal	North: Plot No. - SAME PLOT
Project Type: Building Permission	South: Plot No. - SAME PLOT
Nature of Development: New	East: Road Width - 6.10
Location of Development Area: Old Area	West: Plot No. - SAME PLOT
AREA DETAILS:	
NET AREA OF PLOT (Minimum)	(A) 119.52 SQ.MT.
Deduction from Gross Plot Area	(A-Deductions) 119.52
Deduction for Balance Plot Area (from Gross Plot Area)	
Common Plot Total	12.10
BALANCE AREA OF PLOT (Net Plot Area - Recreational/Amenity space)	(A-Deductions) 107.41
PLOT AREA FOR COVERAGE (Net Plot Area)	(A-Deductions) 119.52
Plot Area for FAR (Net Plot Area + Road Widening Area)	(A-Deductions) 119.52
COVERAGE CHECK	
Permissible Coverage area (70.00 %)	83.66
Proposed Coverage Area (60.74 %)	72.60
Total Prop. Coverage Area (60.74 %)	72.60
Balance coverage area (9.25 %)	11.06
FAR CHECK	
Perm. FAR Area (2.500)	298.80
Total Perm. FAR area	298.80
Residential FAR	145.21
Proposed FAR Area	145.21
Total Proposed FAR Area	145.21
Consumed FAR (Factor)	1.21
Balance FAR Area	153.59
BUILT UP AREA CHECK	
Total Proposed BuiltUp Area	145.20
ARCHITECT (Regd)	RAM PRATAP SINGH
ENGINEER (Regd)	
SUPERVISOR (Regd)	
OWNER (Regd)	SMT. SABITA SHARMA
DEVELOPMENT AUTHORITY	LOCAL BODY

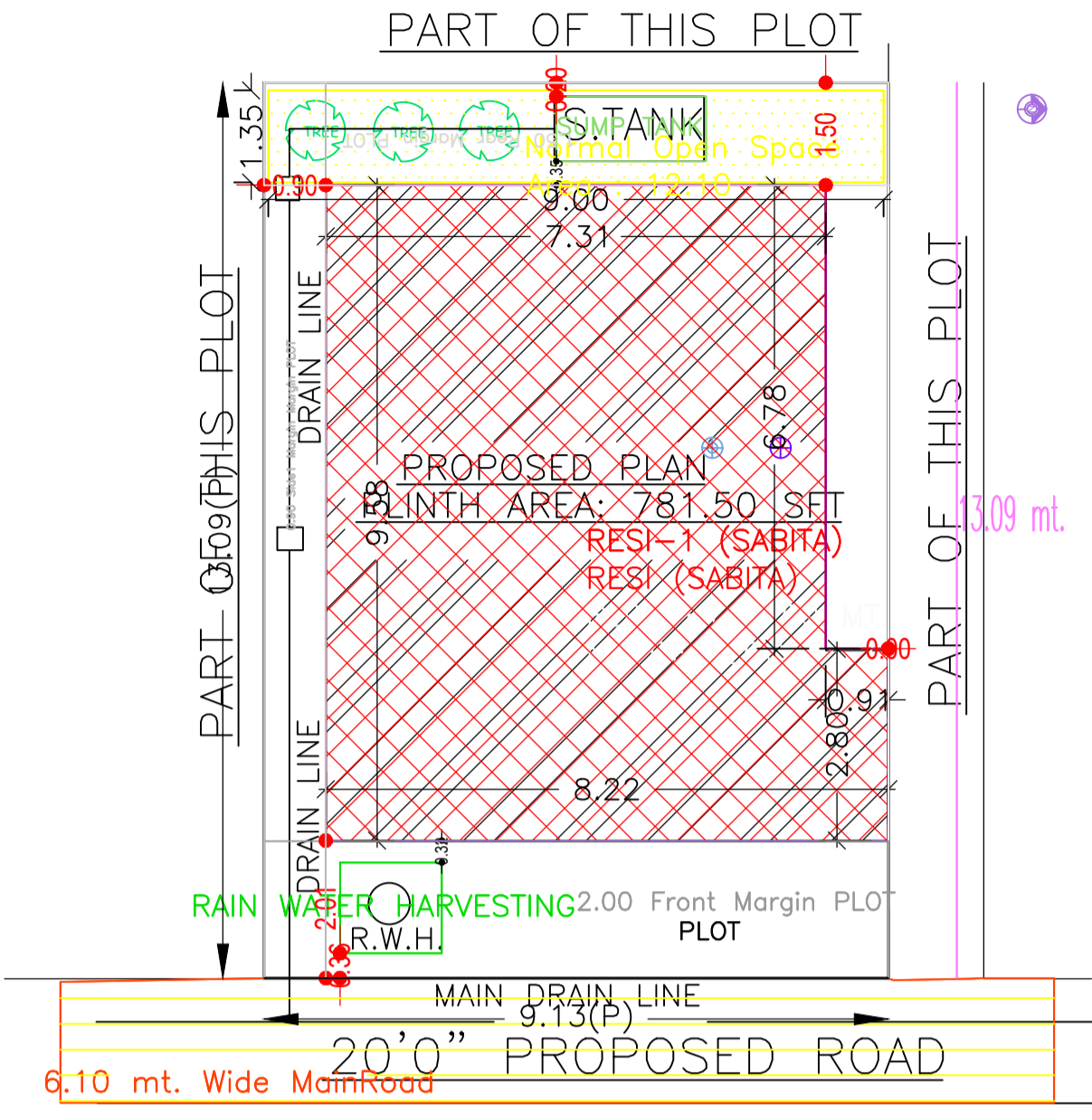

SITE PLAN

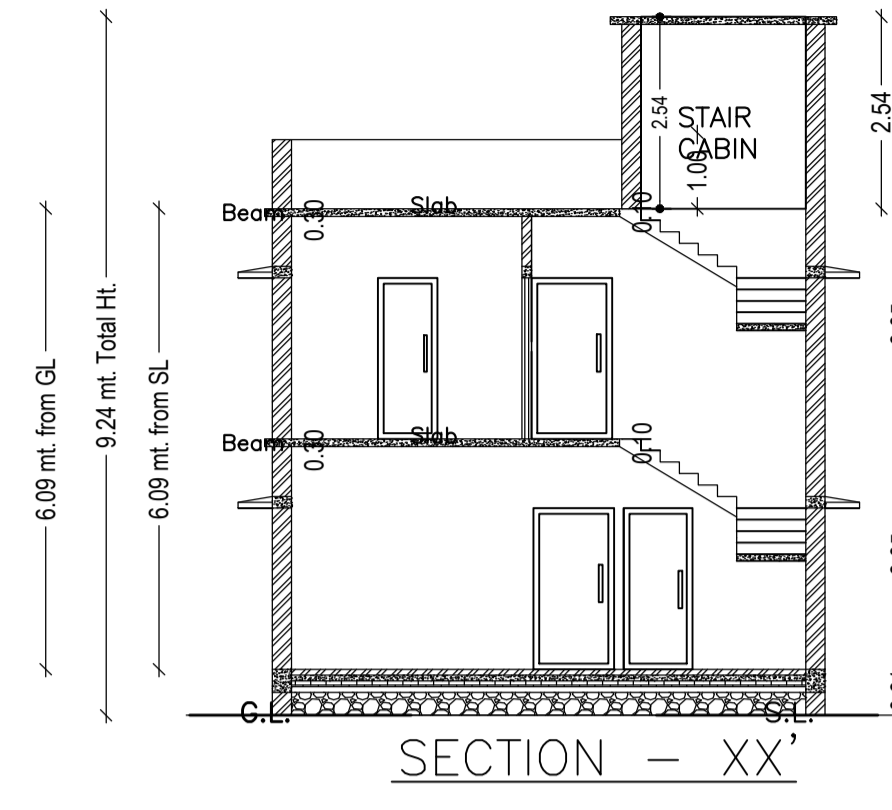

SECTION - XX'

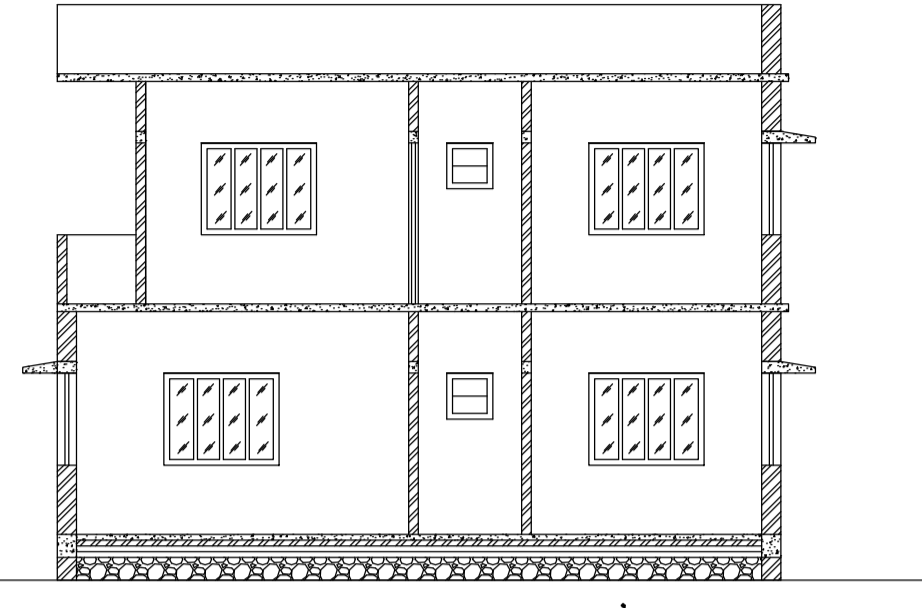

SECTION - YY'

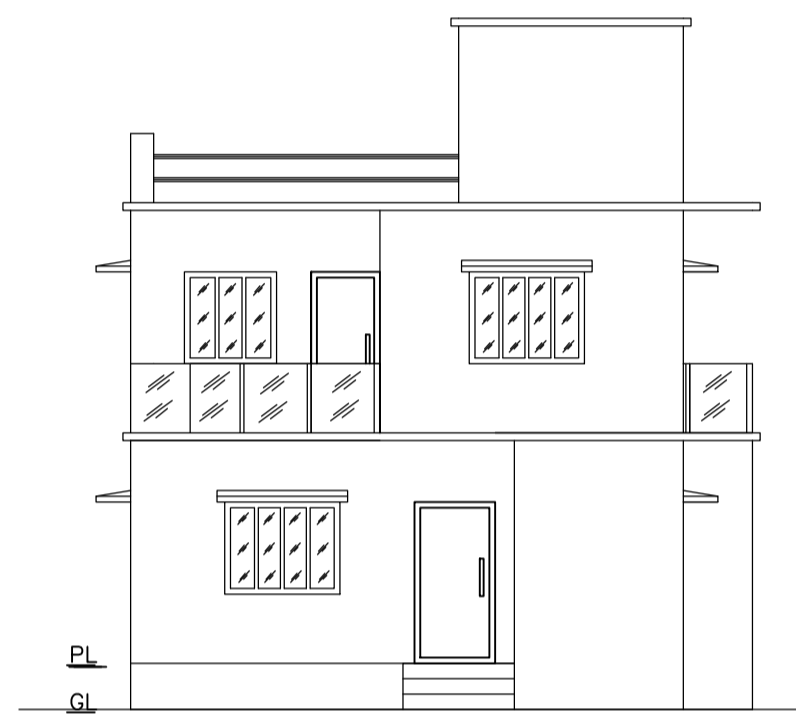

FRONT ELEVATION

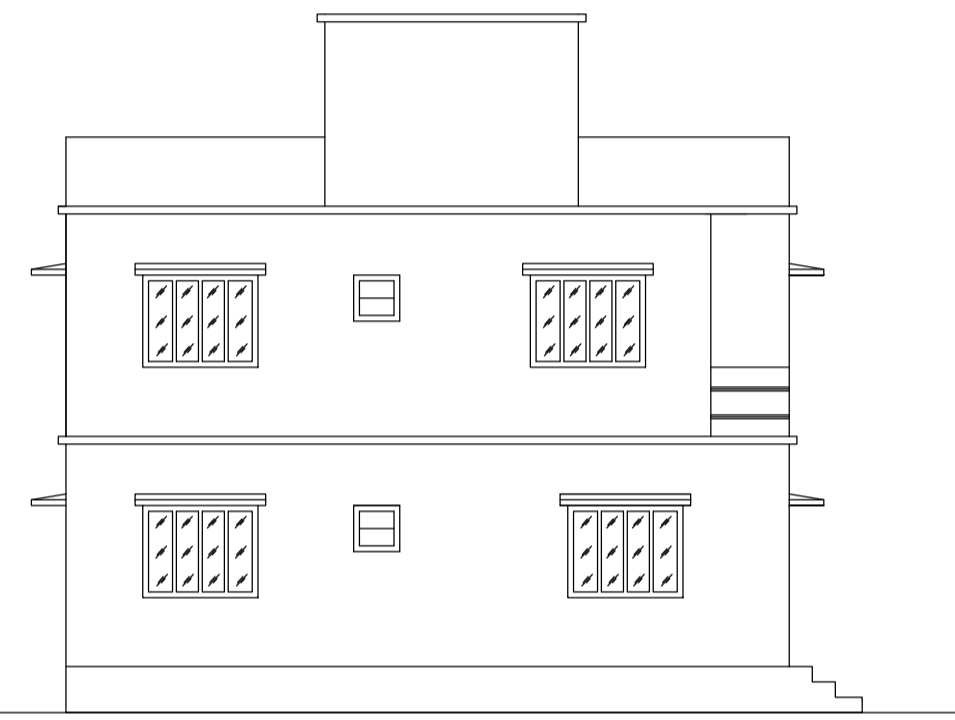

LEFT SIDE ELEVATION

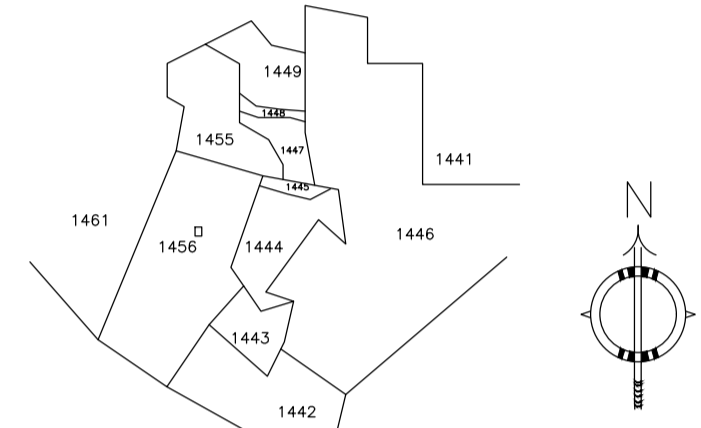

KEY PLAN
SCALE: 1" = 330'0"

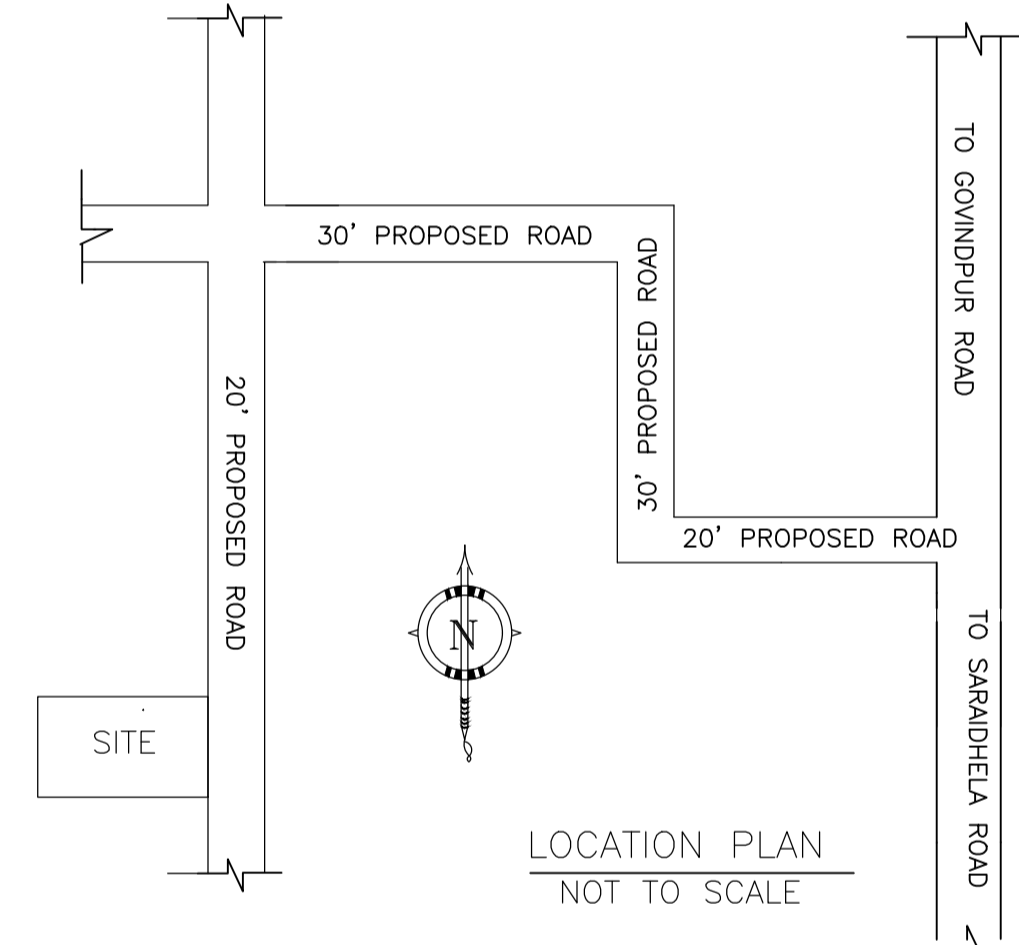

LOCATION PLAN
NOT TO SCALE

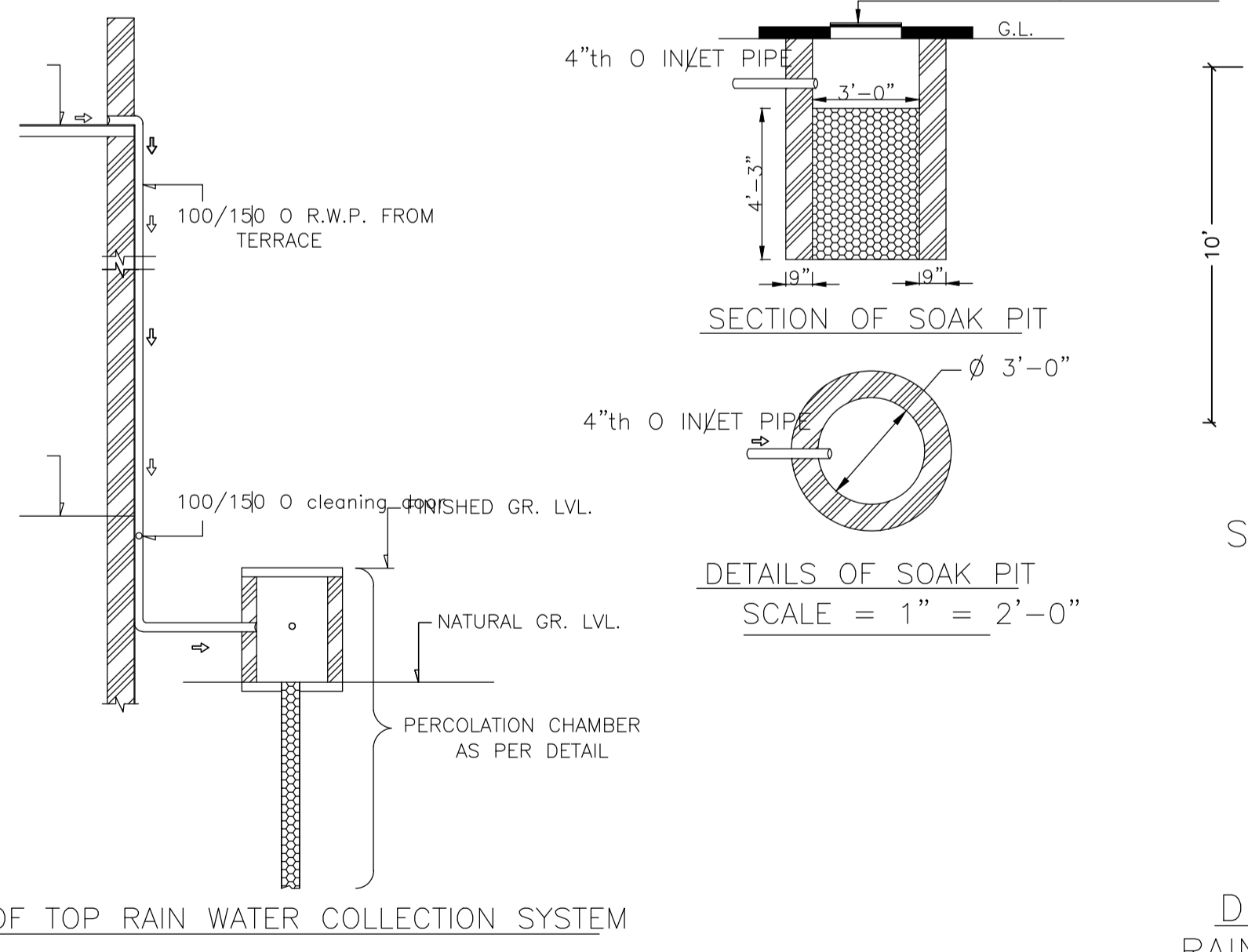

SECTION OF SOAK PIT

DETAILS OF SOAK PIT
SCALE = 1" = 2'-0"

SECTION ON A - B

DETAILS DRAWING OF RAIN WATER HARVESTING

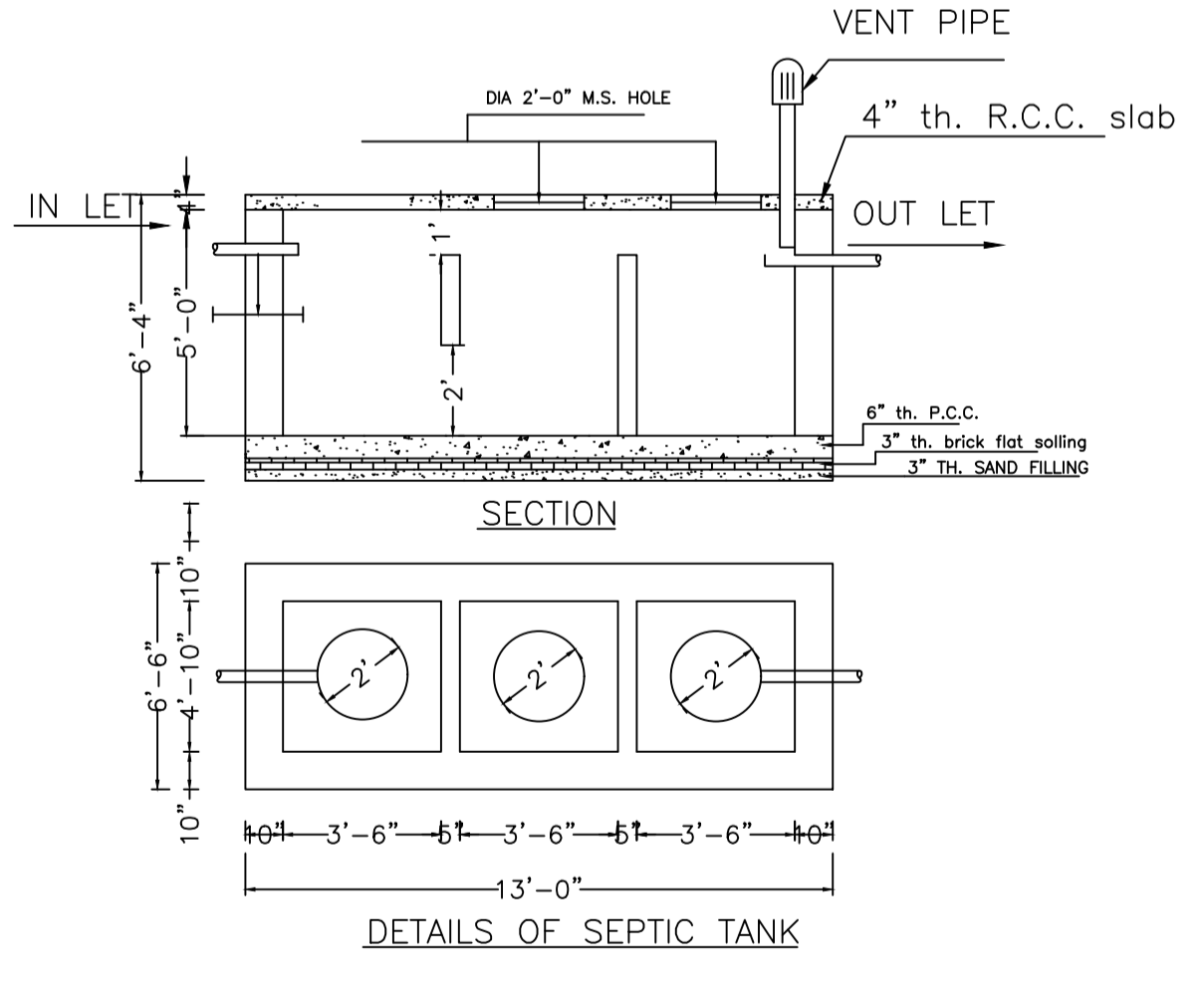

SECTION

DETAILS OF SEPTIC TANK

COLOR INDEX

PLOT BOUNDARY	Black
ABUTTING ROAD	Green
PROPOSED CONSTRUCTION	Red
COMMON PLOT	Yellow
ROAD WIDENING AREA	Blue
EXISTING (To be retained)	Blue
EXISTING (To be demolished)	Yellow

Building :RESI (SABITA)

Floor Name	Total Built Up Area (Sq.mt.)	Proposed FAR Area (Sq.mt.) Resi.	Total FAR Area (Sq.mt.)	Total Consumed Additional FAR Area (Sq.mt.)	Tnmt (No.)
Ground Floor	72.60	72.60	72.60	72.60	01
First Floor	72.60	72.60	72.60	72.60	00
Terrace Floor	0.00	0.00	0.00	0.00	00
Total:	145.20	145.20	145.20	145.20	01
Total Number of Same Buildings	1				
Total:	145.20	145.20	145.20	145.20	01

SCHEDULE OF DOOR:

BUILDING NAME	NAME	LENGTH	HEIGHT	NOS
RESI (SABITA)	D	0.76	2.10	04
RESI (SABITA)	D	0.91	2.10	03
RESI (SABITA)	D	0.94	2.10	01
RESI (SABITA)	D	1.07	2.10	03
RESI (SABITA)	D	1.32	2.10	01

SCHEDULE OF WINDOW/VENTILATION:

BUILDING NAME	NAME	LENGTH	HEIGHT	NOS
RESI (SABITA)	W	0.61	1.20	03
RESI (SABITA)	W	0.91	1.20	04
RESI (SABITA)	W	1.22	1.20	03
RESI (SABITA)	W	1.52	1.20	07
RESI (SABITA)	W	1.54	1.20	01

UnitBUA Table for Building :RESI (SABITA)

FLOOR	Name	UnitBUA Type	UnitBUA Area	Carpet Area	No. of Rooms	No. of Tenement
GROUND FLOOR PLAN	SPLIT 1	FLAT	145.21	143.90	5	1
FIRST FLOOR PLAN	SPLIT 1	FLAT	0.00	0.00	8	0
Total:	-	-	145.21	143.90	13	1

Buildingwise Floor FAR Details

Floor Name	Building Name RESI (SABITA)		Total	
	Proposed Built Up Area (Sq.mt.)	Proposed FAR Area (Sq.mt.)	Total Proposed Built Up Area (Sq.mt.)	Total FAR Area (Sq.mt.)
Ground Floor	72.60	72.60	72.60	72.60
First Floor	72.60	72.60	72.60	72.60
Terrace Floor	0.00	0.00	0.00	0.00
Total:	145.20	145.20	145.20	145.20

Building USE/SUBUSE Details

Building Name	Building Use	Building SubUse	Building Structure
RESI (SABITA)	Residential	Bungalow/ Dwelling / Non Apartment	Non-Highrise

FAR & Tenement Details (Table 4c-1)

Building	No. of Same Bldg	Total Built Up Area (Sq.mt.)	Proposed FAR Area (Sq.mt.) Resi.	Total FAR Area (Sq.mt.)	Total Consumed Additional FAR Area (Sq.mt.)	Tnmt (No.)
RESI (SABITA)	1	145.20	145.20	145.20	145.20	01
Grand Total:	1	145.20	145.20	145.20	145.20	01

LTP NAME AND SIGNATURE	STRUCTURAL ENG'S NAME AND SIGNATURE	BUILDER NAME AND SIGNATURE	DIGITAL SIGNATURE
RAM PRATAP SINGH MADA/ARC/0024/2019			

Proposal Basic Information	
Proposal File No.	MADA/BP/0364/2022
Owner Name	SMT. SABITA SHARMA
Khata No	OLD KHATA NO- 69, NEW KHATA NO-134
Plot No	OLD PLOT NO- 517, NEW PLOT NO-1456
Village Name	Jialgora
Use	Residential
SubUse	Bungalow/ Dwelling / Non Apartment

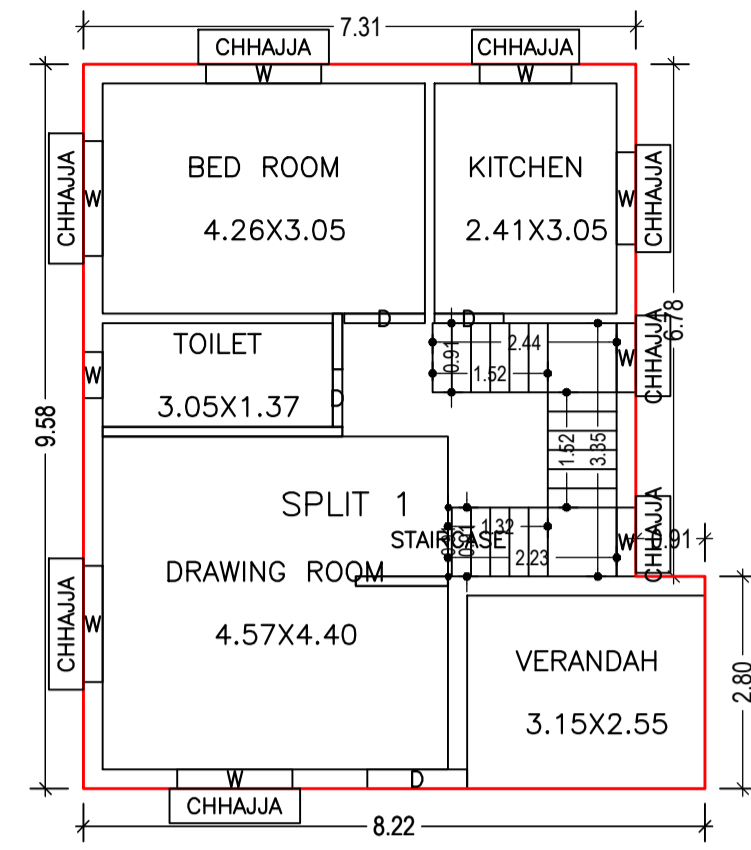

GROUND FLOOR PLAN
(Proposed)
(SCALE 1:100)

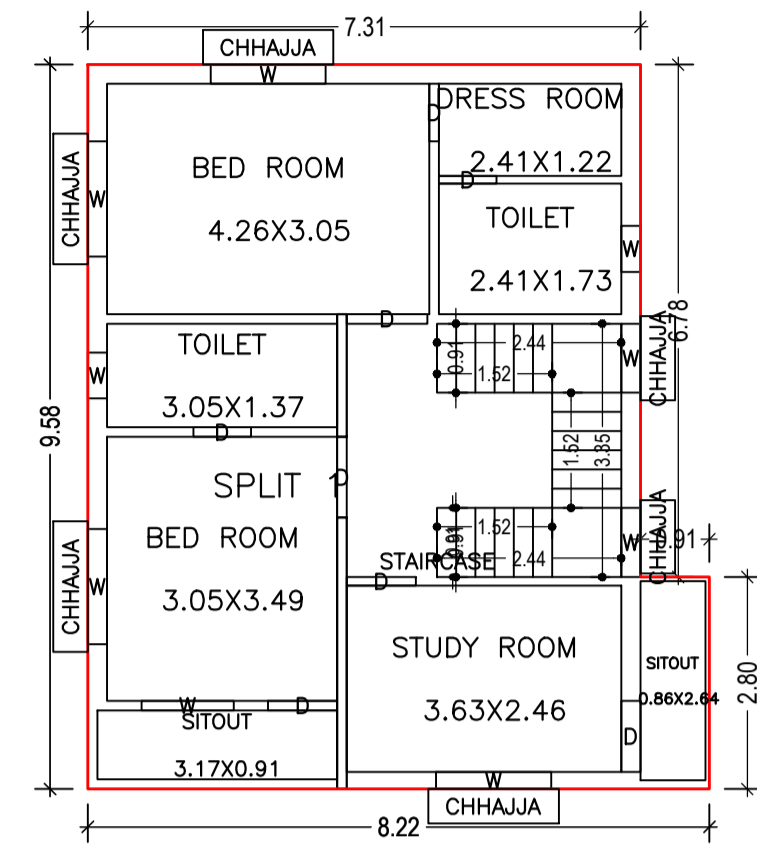

FIRST FLOOR PLAN
(Proposed)
(SCALE 1:100)

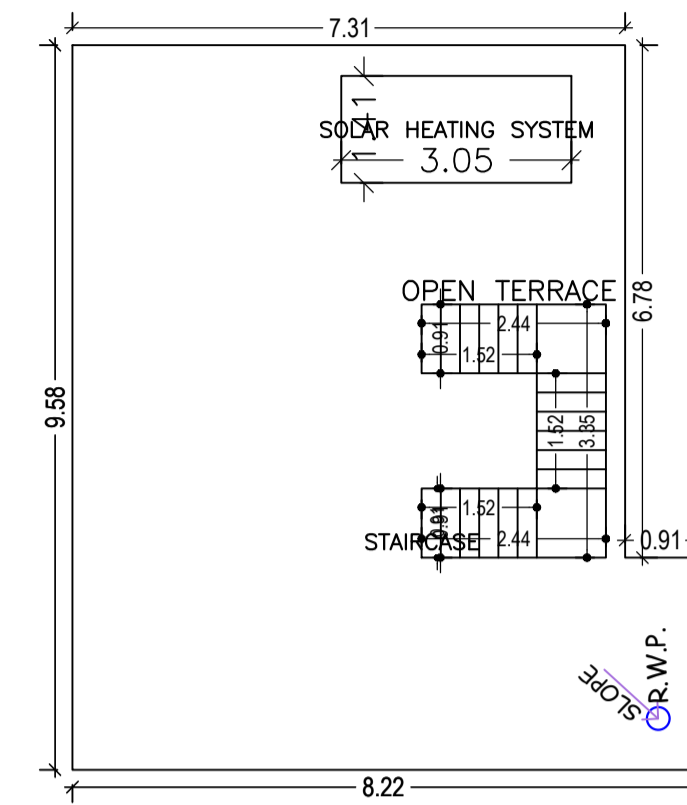

TERRACE FLOOR PLAN
(SCALE 1:100)

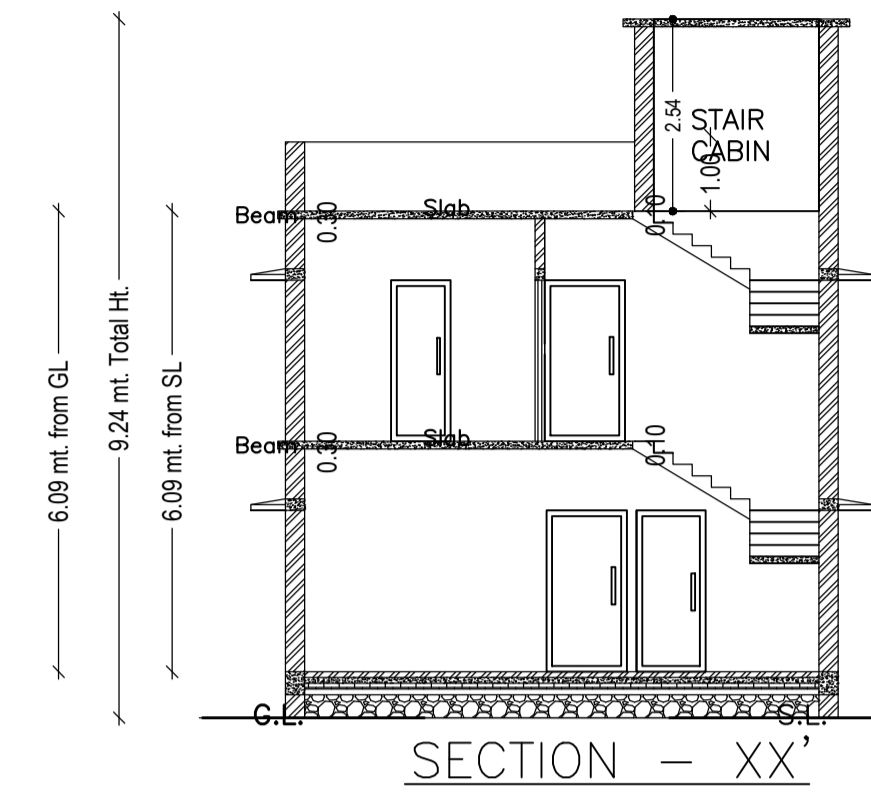

SECTION - XX'

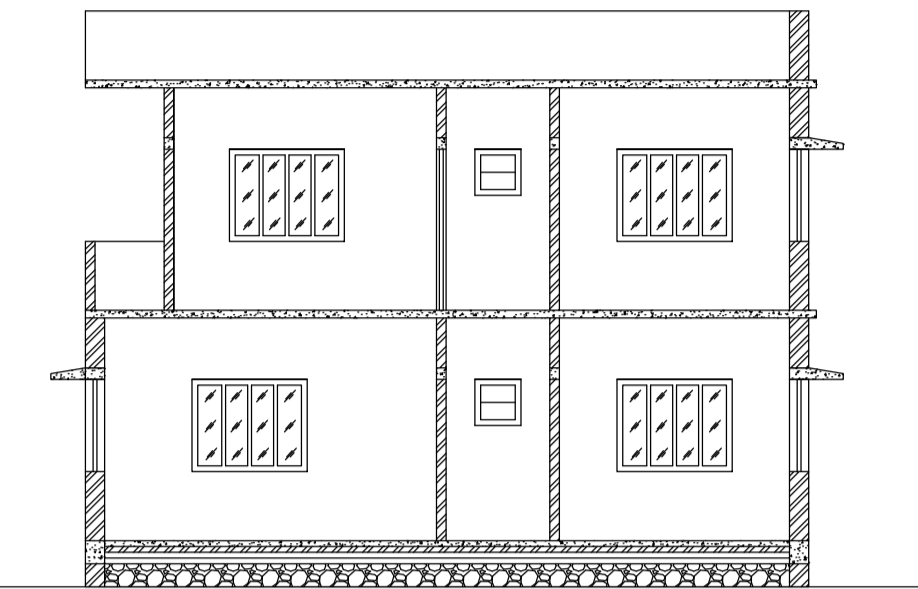

SECTION - YY'

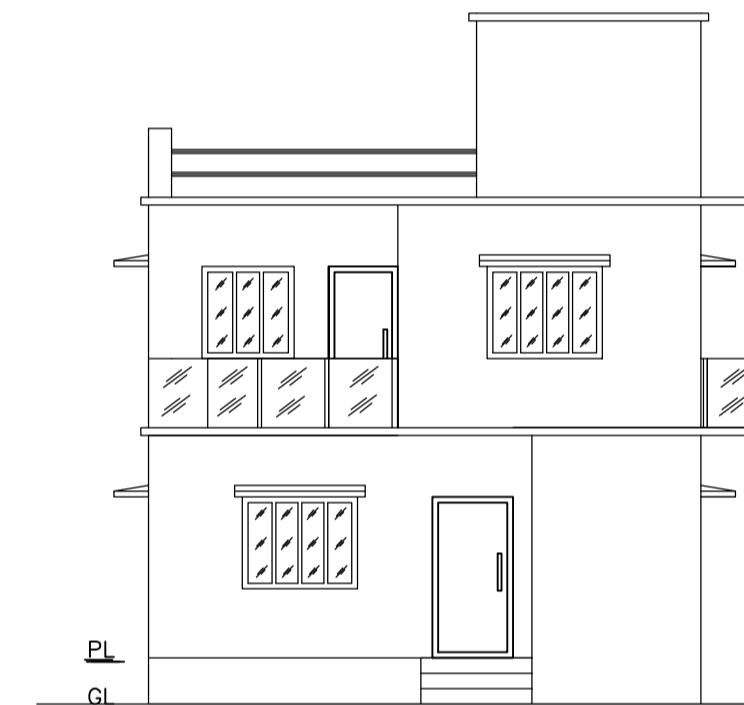

FRONT ELEVATION

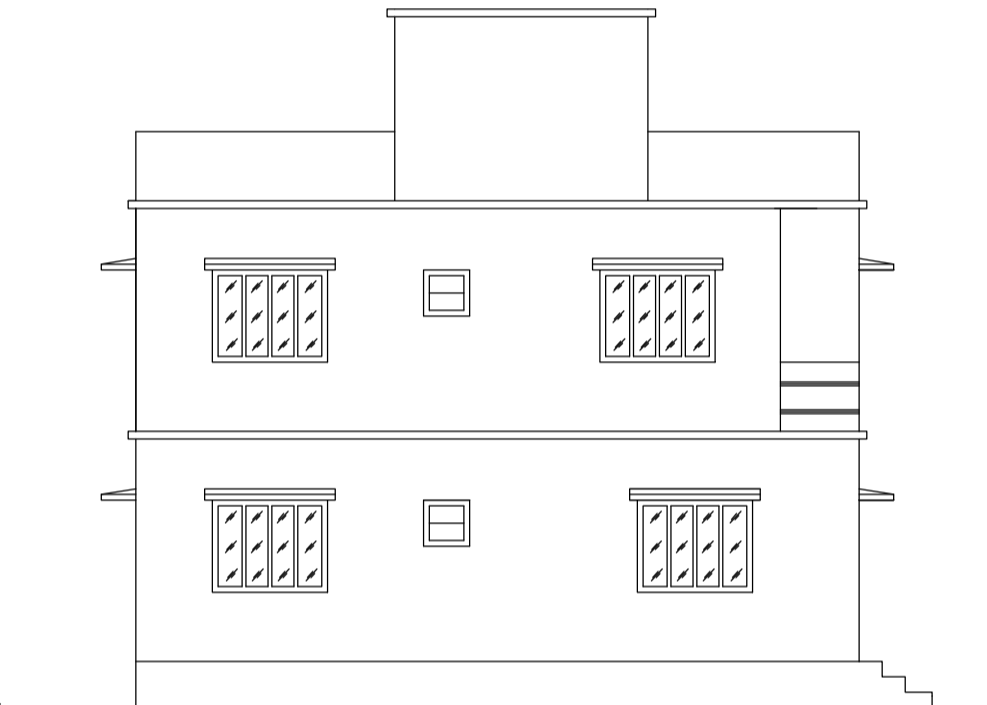

LEFT SIDE ELEVATION

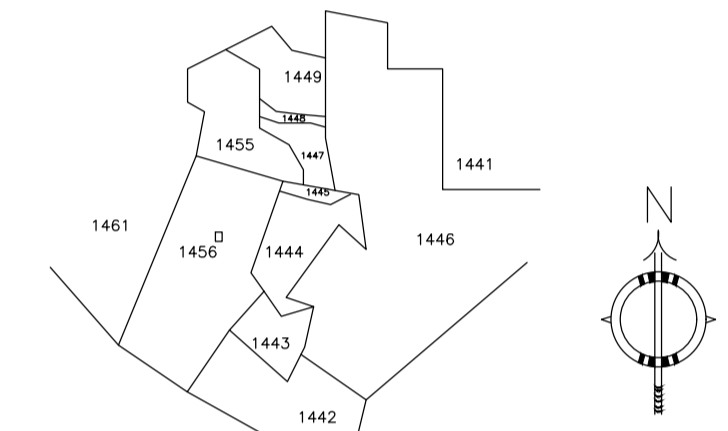

KEY PLAN
SCALE:- 1"=330'0"

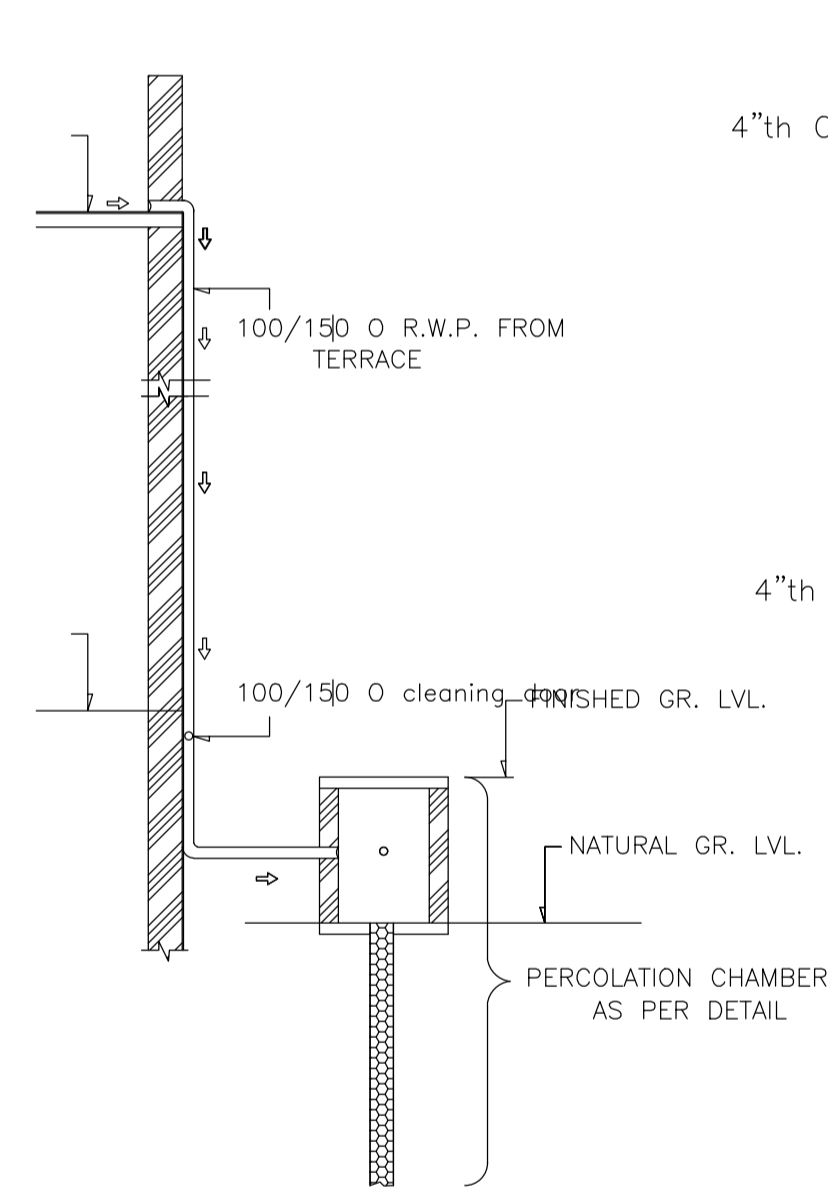

ROOF TOP RAIN WATER COLLECTION SYSTEM

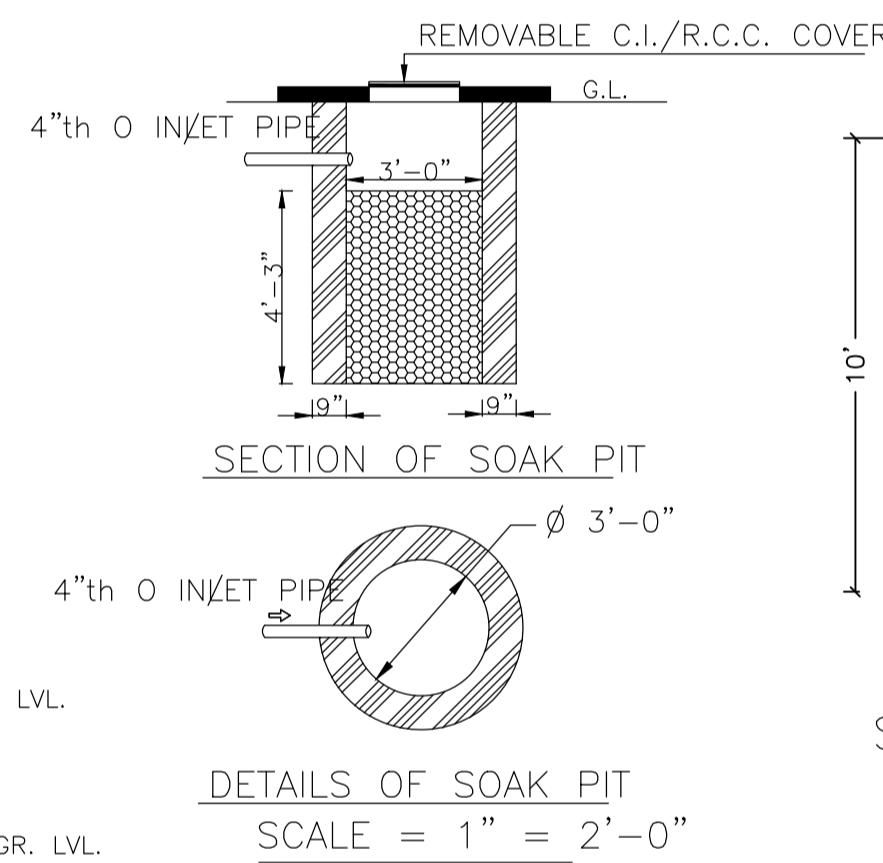

SECTION ON A - B

DETAILS DRAWING OF RAIN WATER HARVESTING

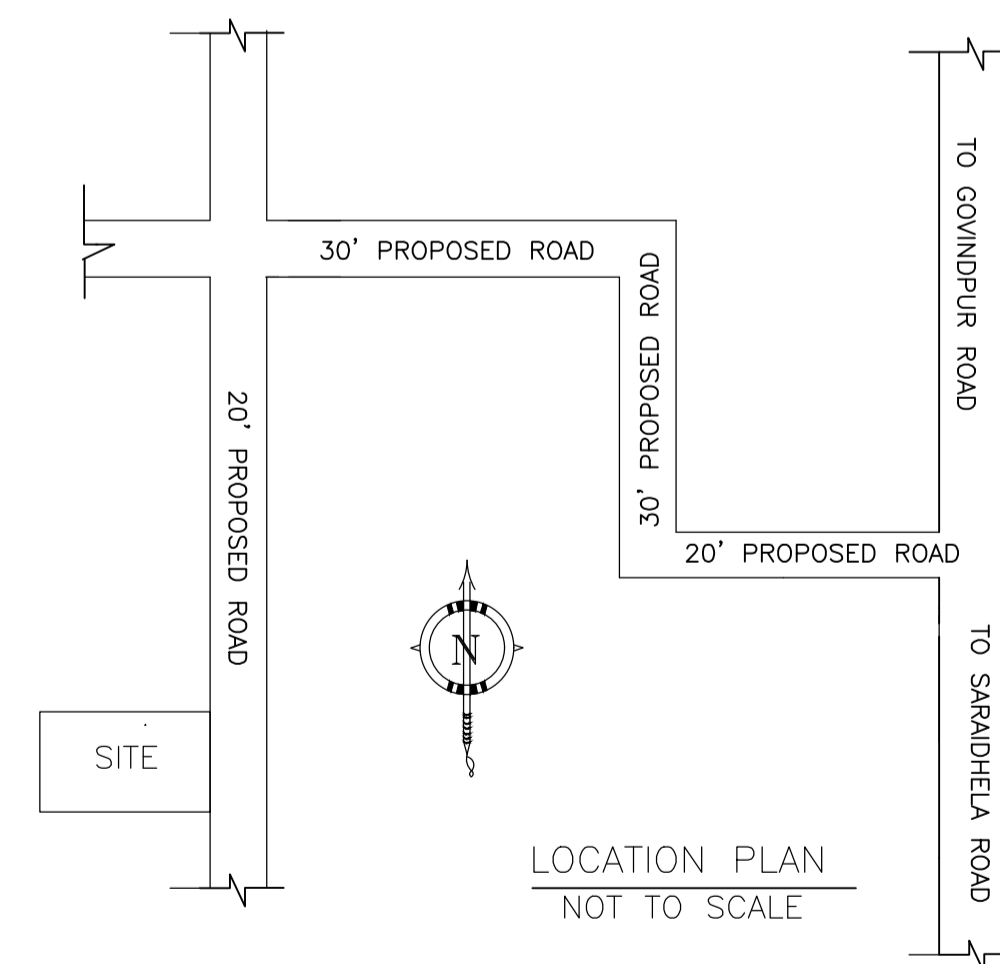

LOCATION PLAN
NOT TO SCALE

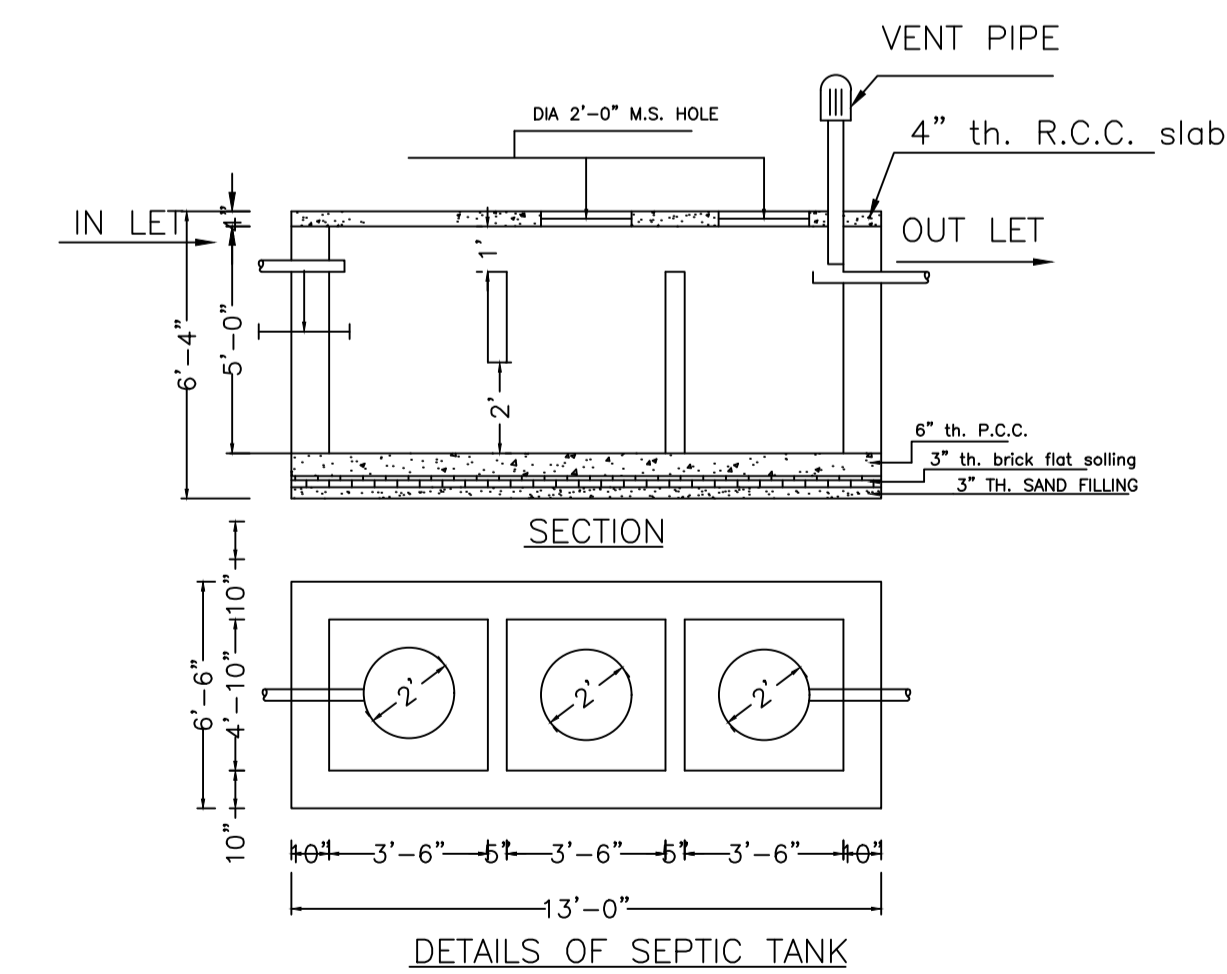

DETAILS OF SEPTIC TANK

LTP NAME AND SIGNATURE	STRUCTURAL ENG'S NAME AND SIGNATURE	BUILDER NAME AND SIGNATURE	DIGITAL SIGNATURE
RAM PRATAP SINGH MADA/ARC/0024/2019			