

Proposal Basic Information

Proposal File No.	MADA/BP/0309/2022
Owner Name	SRI BIKESH KUMAR SINGH
Khata No	126(OLD), 162(NEW)
Plot No	653(OLD), 1002(NEW)
Village Name	Panduki
Use	Residential
SubUse	Bungalow/ Dwelling / Non Apartment

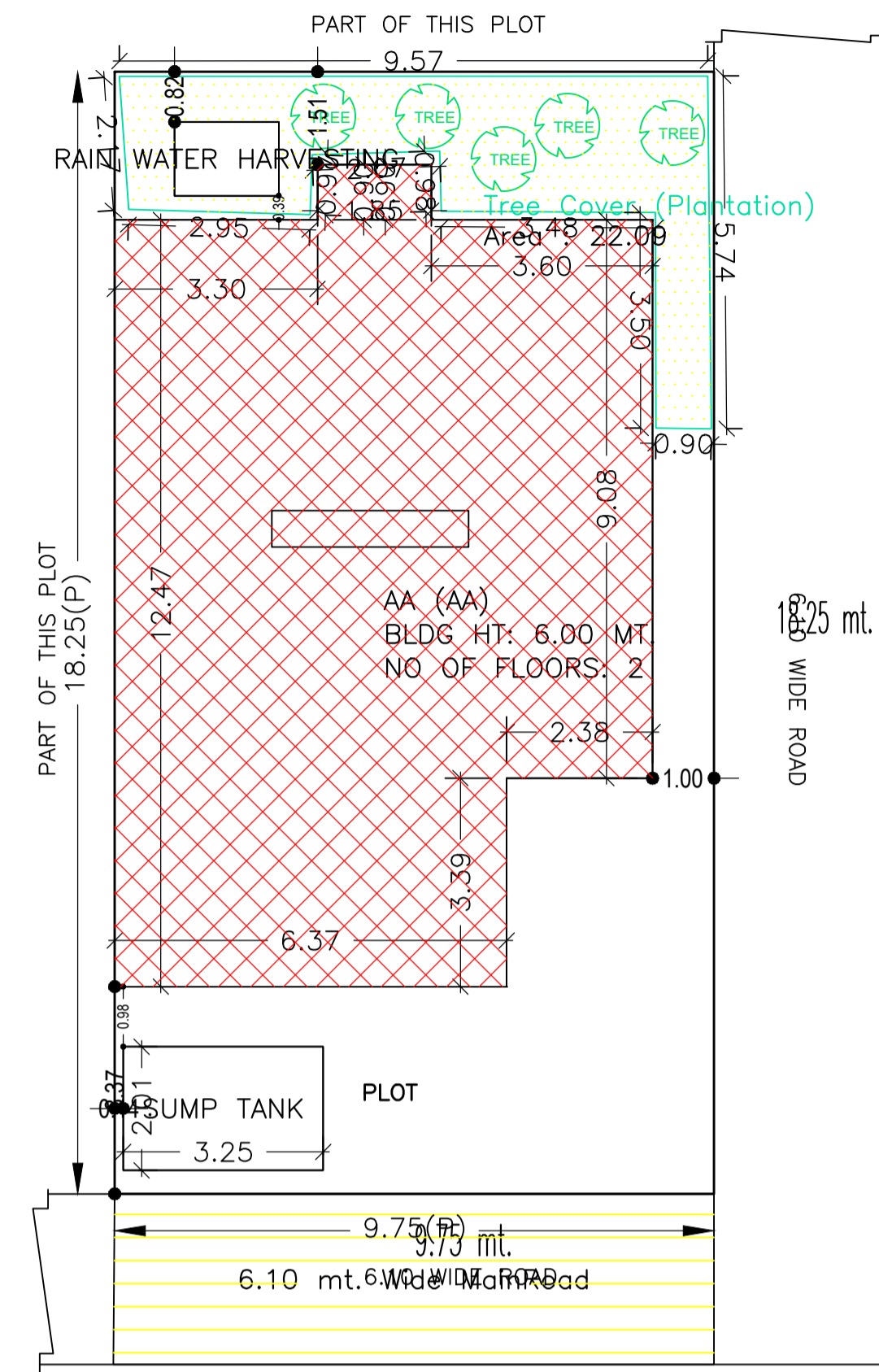

SITE PLAN

SCHEDULE OF DOOR:

BUILDING NAME	NAME	LENGTH	HEIGHT	NOS
AA (AA)	D2	0.70	2.10	01
AA (AA)	D2	0.90	2.10	09
AA (AA)	D1	0.98	2.10	02
AA (AA)	D2	1.05	2.10	01
AA (AA)	D1	1.05	2.10	01
AA (AA)	D1	1.20	2.10	01
AA (AA)	D2	1.20	2.10	01
AA (AA)	D	1.20	2.10	04

SCHEDULE OF WINDOW/VENTILATION:

BUILDING NAME	NAME	LENGTH	HEIGHT	NOS
AA (AA)	V	0.60	1.20	04
AA (AA)	V	0.90	1.20	02
AA (AA)	W	1.80	1.20	05
AA (AA)	W	2.40	1.20	02

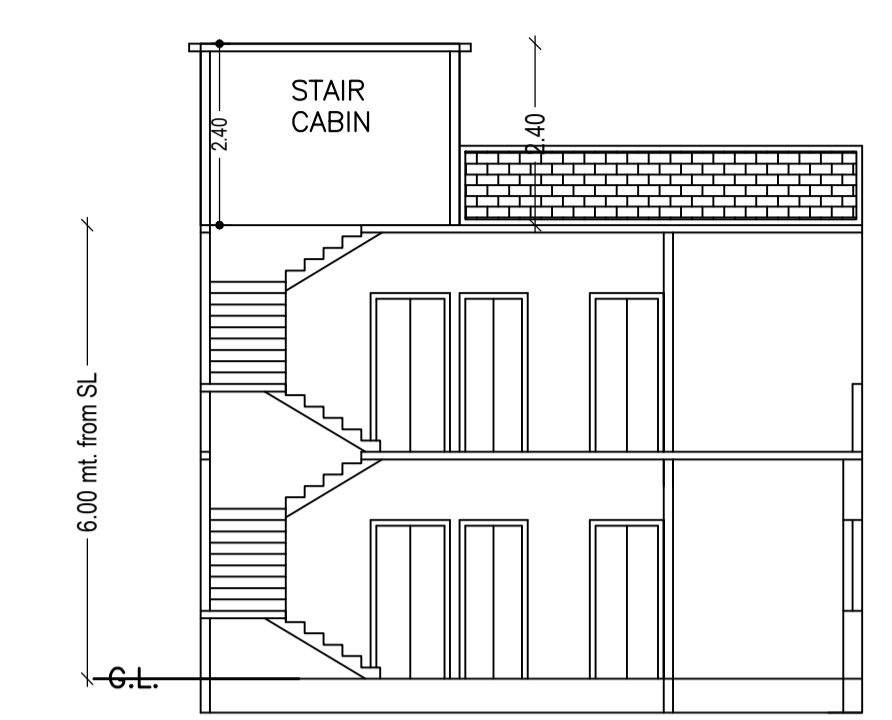

SECTION ON X-X

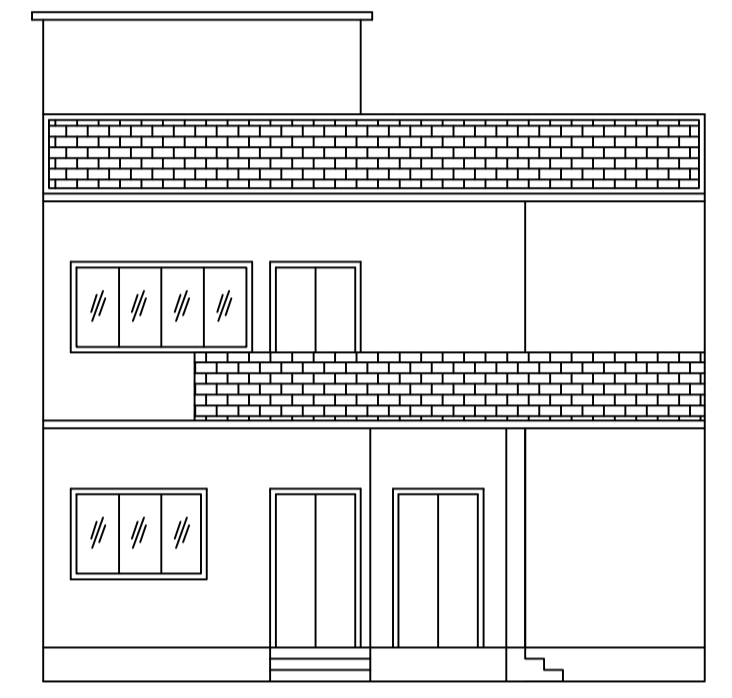

FRONT ELEVATION

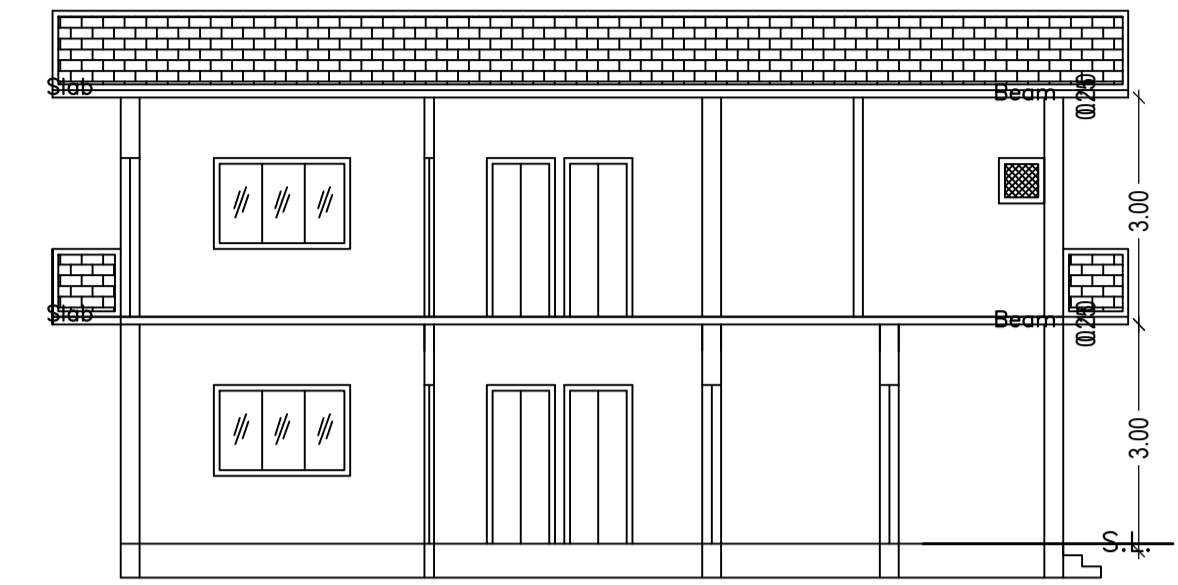

SECTION ON Y-Y

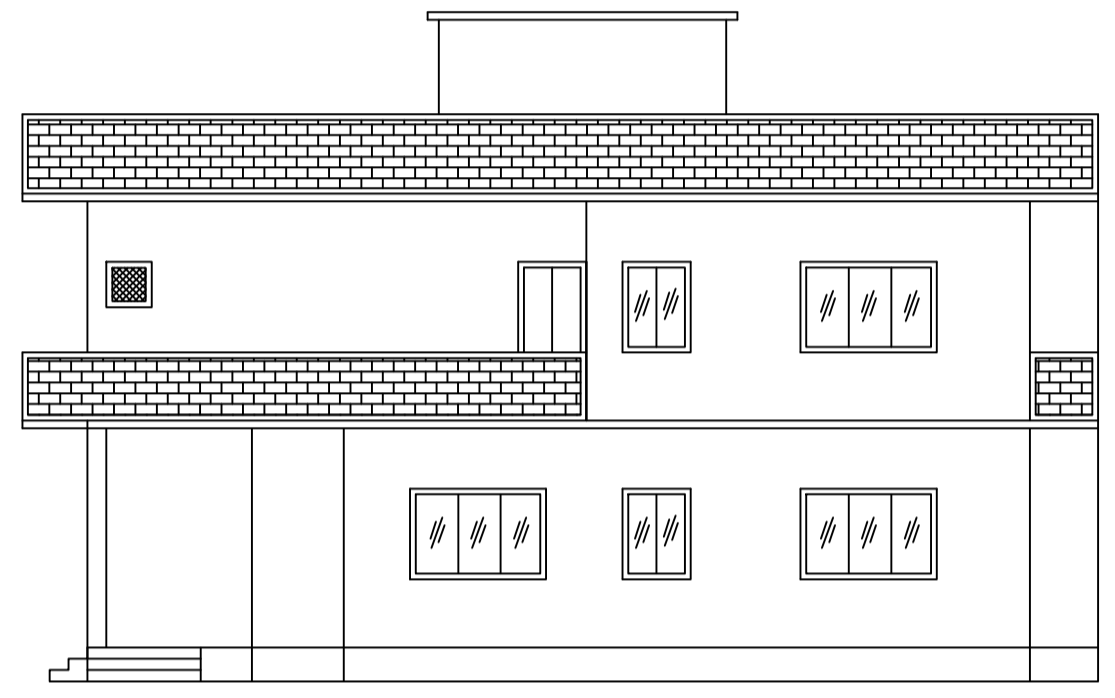

RIGHT SIDE ELEVATION

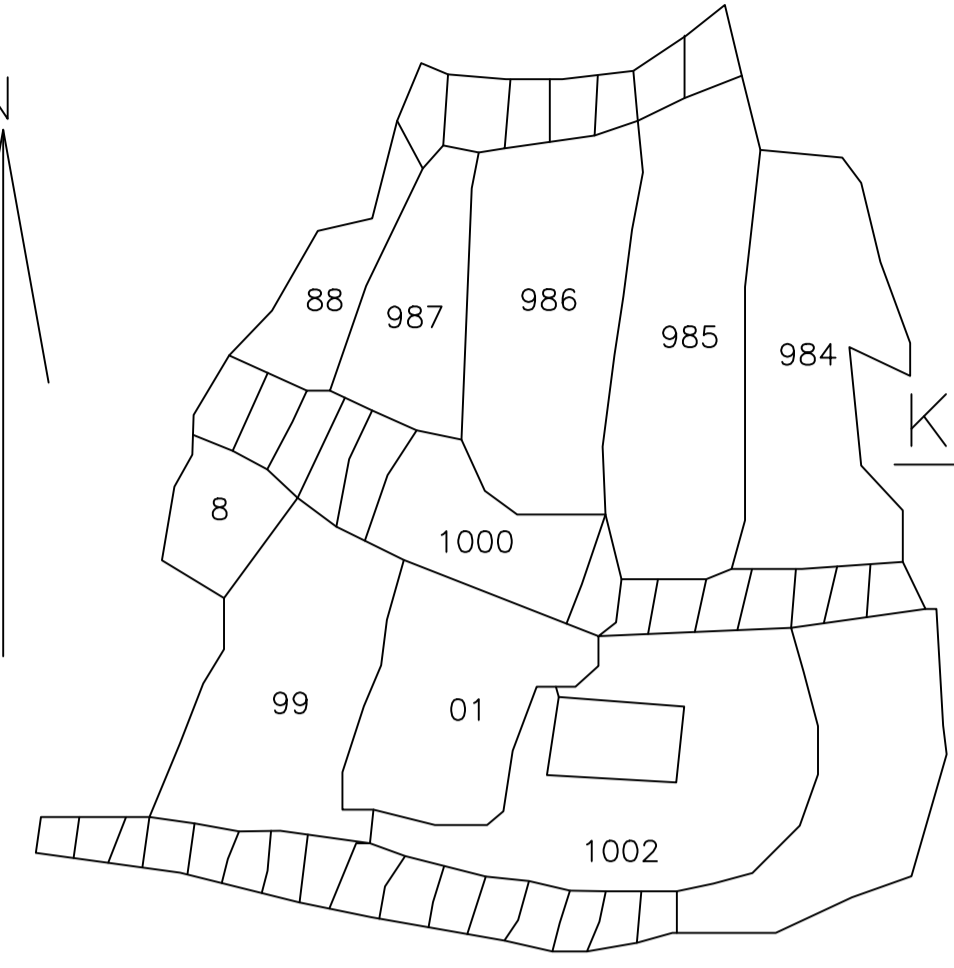

KEY PLAN

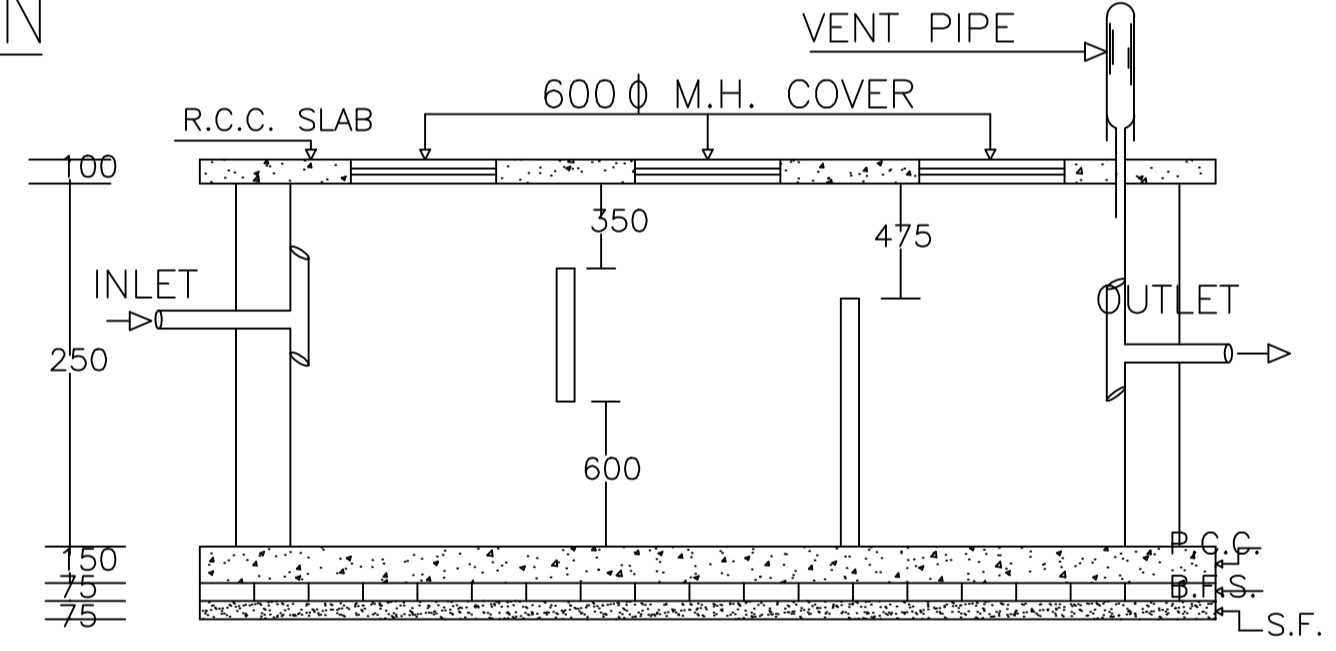
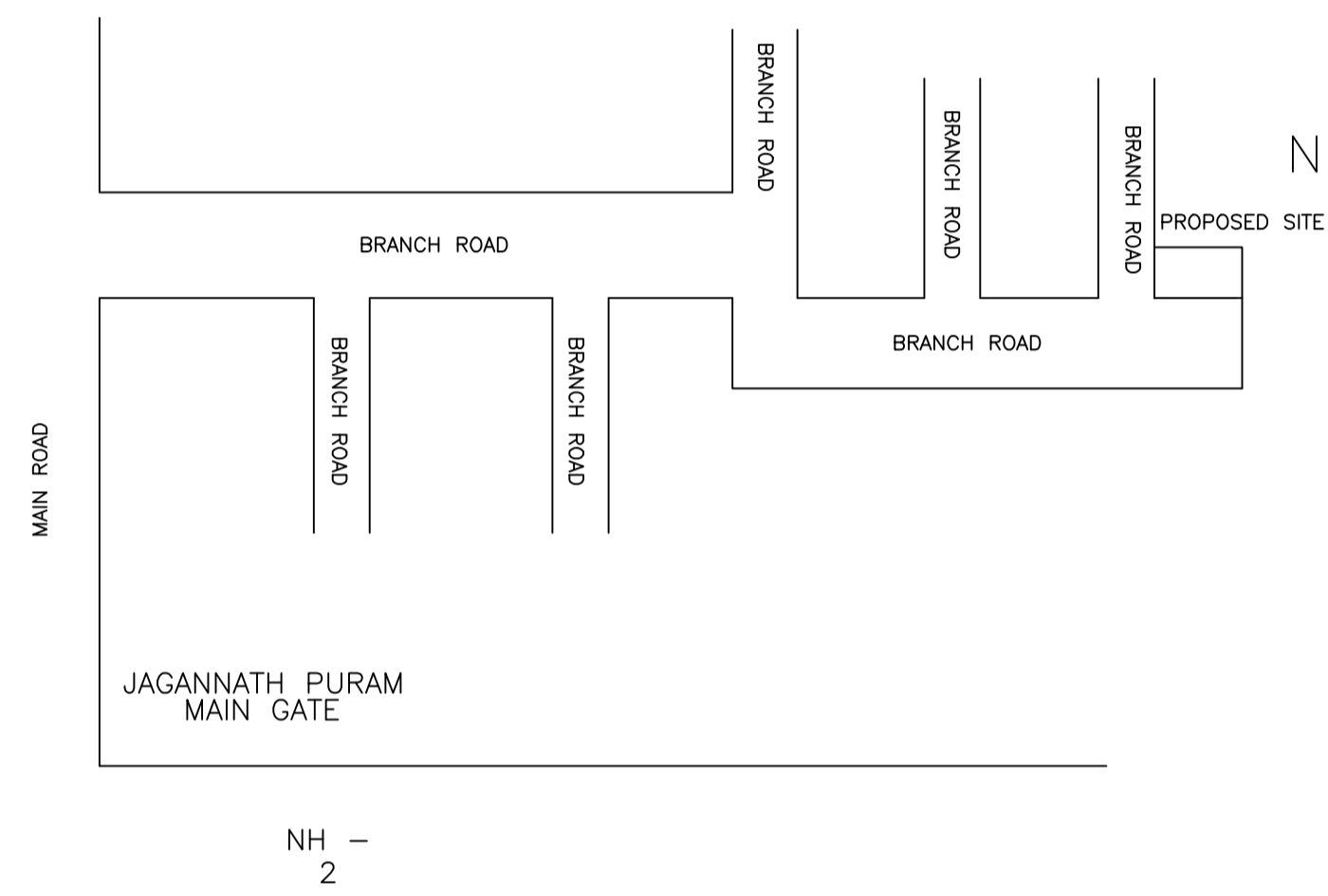

PLAN OF SEPTIC TANK

Building :AA (AA)

Floor Name	Total Built Up Area (Sq.mt.)	Proposed FAR Area (Sq.mt.)	Total FAR Area (Sq.mt.)	Total Consumed Additional FAR Area (Sq.mt.)	Tnmt (No.)
Ground Floor	102.73	102.73	102.73	102.73	01
First Floor	87.92	87.92	87.92	87.92	00
Terrace Floor	0.00	0.00	0.00	0.00	00
Total :	190.65	190.65	190.65	190.65	01
Total Number of Same Buildings	1				
Total :	190.65	190.65	190.65	190.65	01

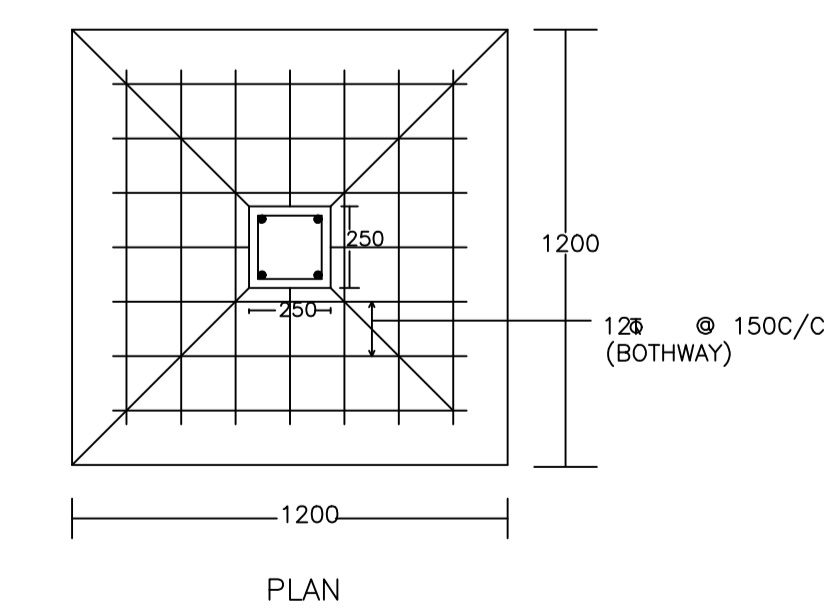
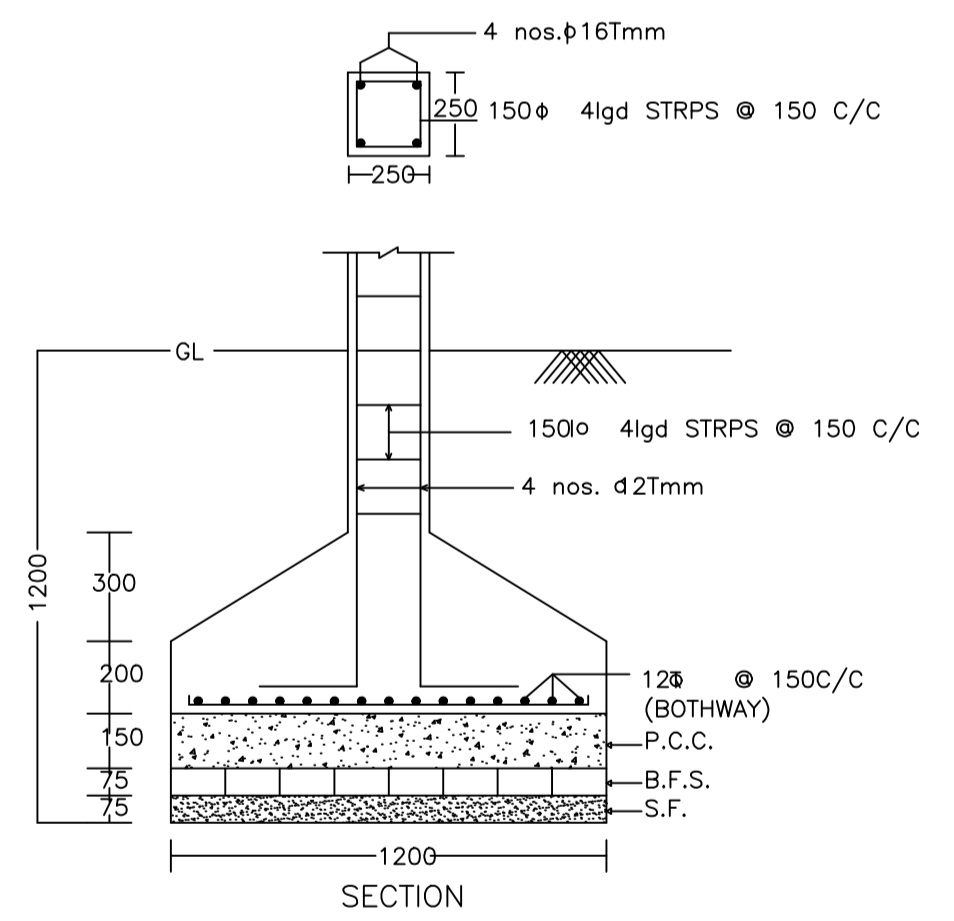

DETAIL OF COLUMNS

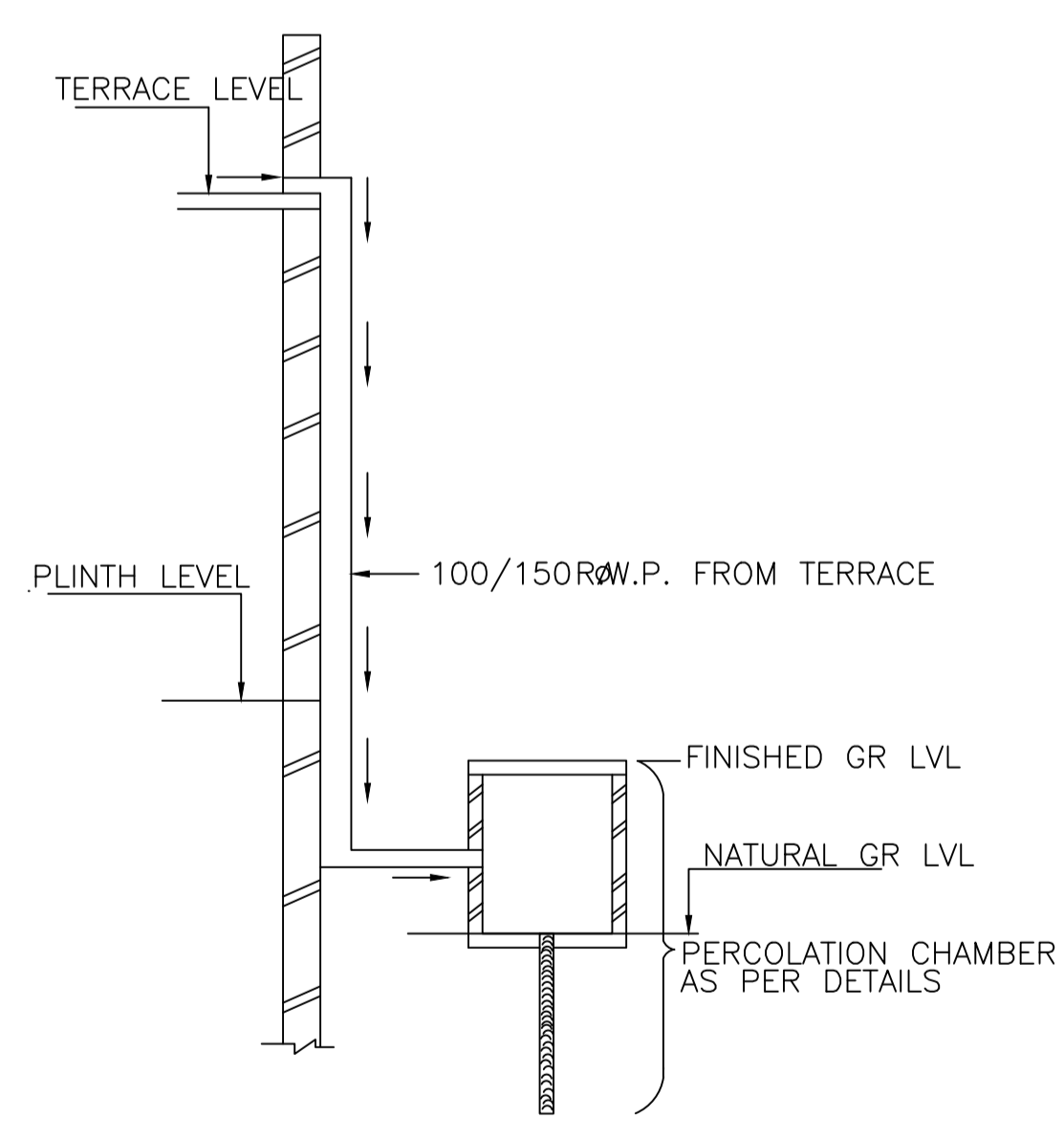

ROOF TOP RAIN WATER COLLECTION SYSTEM

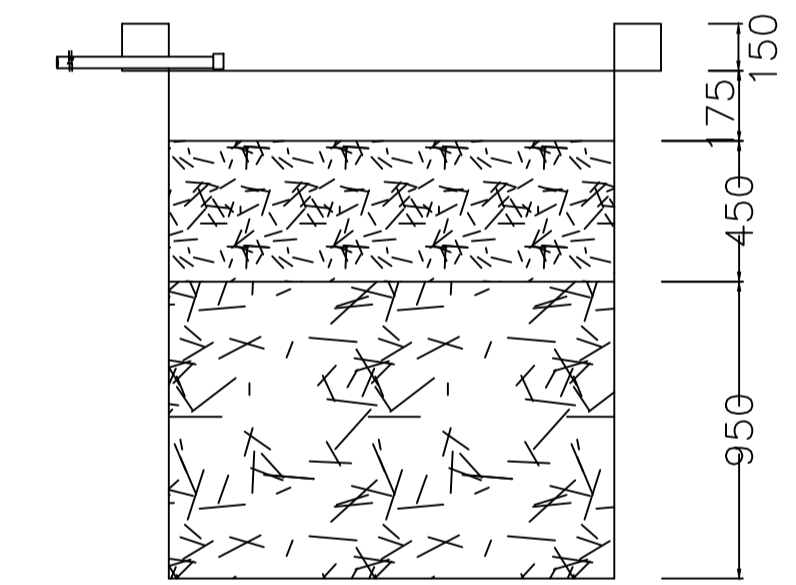

SECTION AT Y-Y

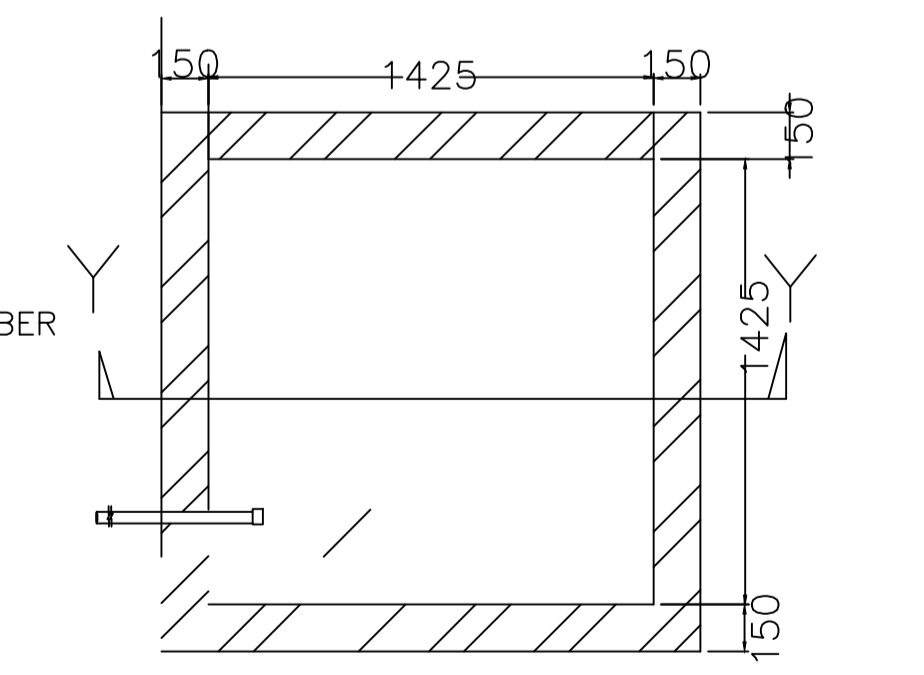

PLAN OF RECHARGE WELL WATER HARVESTING

AREA STATEMENT MINERAL AREA DEVELOPMENT AUTHORITY

VERSION NO.: 1.0.64
VERSION DATE: 16/10/2020

PROJECT DETAIL:

Region: JHARKHAND URBAN LOCAL BODIES	Plot Use: Residential
District: DHANBAD	Plot SubUse: Bungalow/ Dwelling / Non Apartment
Authority: MINERAL AREA DEVELOPMENT AUTHORITY	PlotNearbyReligiousStructure: NA
Inward No: MADA/BP/0309/2022	Plot/SubPlot No: 653(OLD), 1002(NEW)
Application Type: General Proposal	North: Plot No. - PART OF THIS PLOT
Project Type: Building Permission	South: Road Width - 6.10
Nature of Development: New	East: Plot No. - PART OF THIS PLOT
Location of Development Area: Old Area	West: Road Width - 6.10 WIDE ROAD

AREA DETAILS:

DESCRIPTION	UNIT	VALUE
AREA OF PLOT (Minimum)	(A)	177.94
NET AREA OF PLOT/Gross Plot Area - Deduction from Gross Plot area	(A-Deductions)	177.94
Deduction for Balance Plot Area(from Gross Plot Area)		
Common Plot		22.09
Total		22.09
BALANCE AREA OF PLOT(Net Plot Area - Recreational/Amenity space)	(A-Deductions)	155.85
PLOT AREA FOR COVERAGE(Net Plot Area)	(A-Deductions)	177.94
Plot Area for FAR (Net Plot Area + Road/Widening Area)	(A-Deductions)	177.94

COVERAGE CHECK

DESCRIPTION	VALUE
Permissible Coverage area (70.00 %)	124.56
Proposed Coverage Area (57.73 %)	102.73
Total Prop. Coverage Area (57.73 %)	102.73
Balance coverage area (12.27 %)	21.83

FAR CHECK

DESCRIPTION	VALUE
Perm. FAR Area (2.500)	444.85
Total Perm. FAR area	444.85
Residential FAR	190.65
Proposed FAR Area	190.65
Total Proposed FAR Area	190.65
Consumed FAR (Factor)	1.07
Balance FAR Area	254.20

BUILT UP AREA CHECK

DESCRIPTION	VALUE
Total Proposed BuiltUp Area	190.65

ARCHITECT (Regd): RAJEEV RANJAN SINGH
ENGINEER (Regd):
SUPERVISOR (Regd):
OWNER (Regd): SRI BIKESH KUMAR SINGH
DEVELOPMENT AUTHORITY: LOCAL BODY

COLOR INDEX

PLOT BOUNDARY	Black
ABUTTING ROAD	Green
PROPOSED CONSTRUCTION	Red
COMMON PLOT	Yellow
ROAD WIDENING AREA	Blue
EXISTING (To be retained)	White
EXISTING (To be demolished)	Grey

Buildingwise Floor FAR Details

Floor Name	Building Name AA (AA)		Total	
	Proposed Built Up Area (Sq.mt.)	Proposed FAR Area (Sq.mt.)	Total Proposed Built Up Area (Sq.mt.)	Total FAR Area (Sq.mt.)
Ground Floor	102.73	102.73	102.73	102.73
First Floor	87.92	87.92	87.92	87.92
Terrace Floor	0.00	0.00	0.00	0.00
Total :	190.65	190.65	190.65	190.65

Building USE/SUBUSE Details

Building Name	Building Use	Building SubUse	Building Structure
AA (AA)	Residential	Bungalow/ Dwelling / Non Apartment	Non-Highrise

FAR & Tenement Details (Table 4c-1)

Building	No. of Same Bldg	Total Built Up Area (Sq.mt.)	Proposed FAR Area (Sq.mt.)	Total FAR Area (Sq.mt.)	Total Consumed Additional FAR Area (Sq.mt.)	Tnmt (No.)
AA (AA)	1	190.65	190.65	190.65	190.65	01
Grand Total :	1	190.65	190.65	190.65	190.65	01

UnitBUA Table for Building :AA (AA)

FLOOR	Name	UnitBUA Type	UnitBUA Area	Carpet Area	No. of Rooms	No. of Tenement
GROUND FLOOR PLAN	SPLIT aa	FLAT	190.65	190.56	10	1
FIRST FLOOR PLAN	SPLIT aa	FLAT	0.00	0.00	9	0
Total:	-	-	190.65	190.56	19	1

LTP NAME AND SIGNATURE	STRUCTURAL ENG'S NAME AND SIGNATURE	BUILDER NAME AND SIGNATURE	DIGITAL SIGNATURE
RAJEEV RANJAN SINGH MADA/ENG/0004/2019			

Proposal Basic Information	
Proposal File No.	MADA/BP/0309/2022
Owner Name	SRI BIKESH KUMAR SINGH
Khata No	126(OLD), 162(NEW)
Plot No	653(OLD), 1002(NEW)
Village Name	Panduki
Use	Residential
SubUse	Bungalow/ Dwelling / Non Apartment

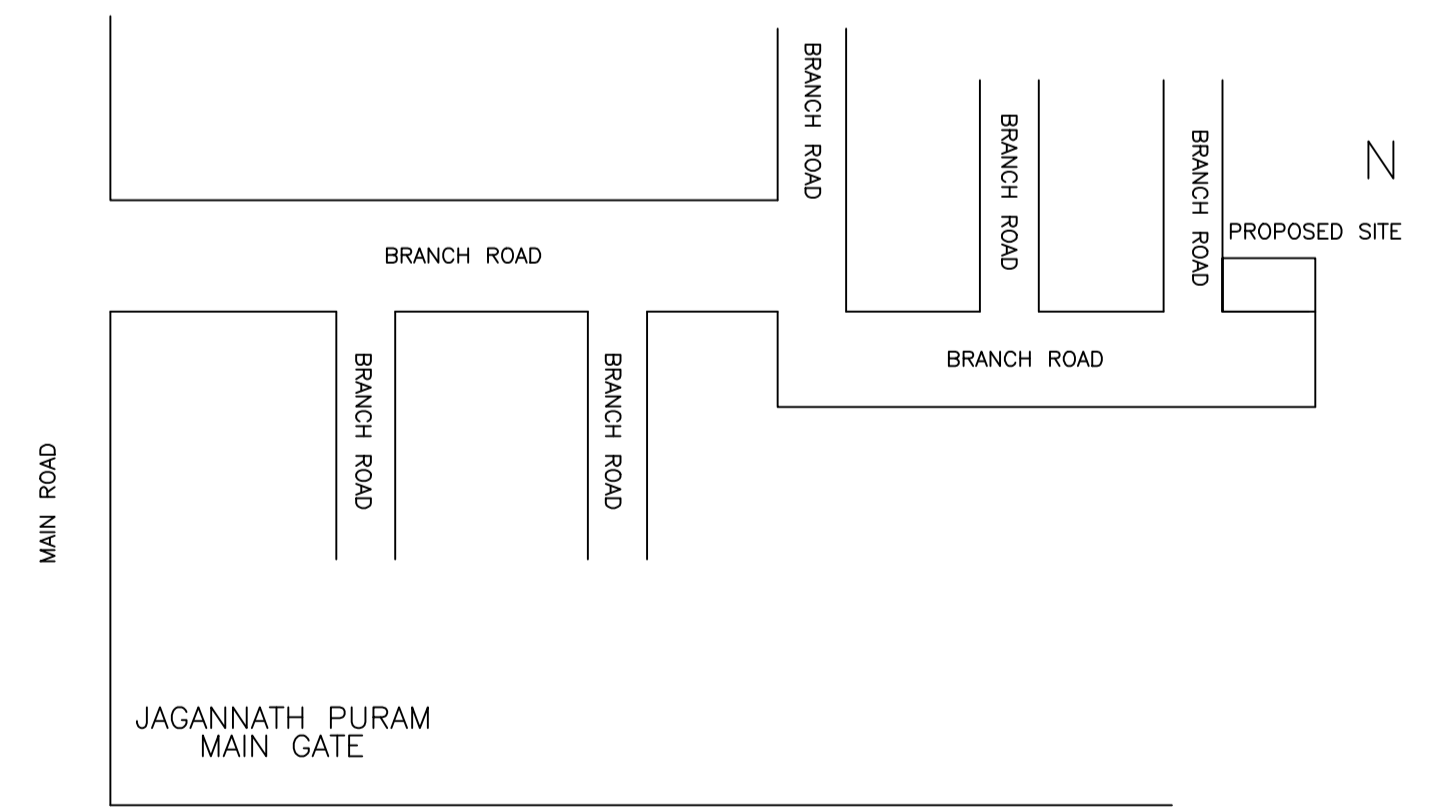
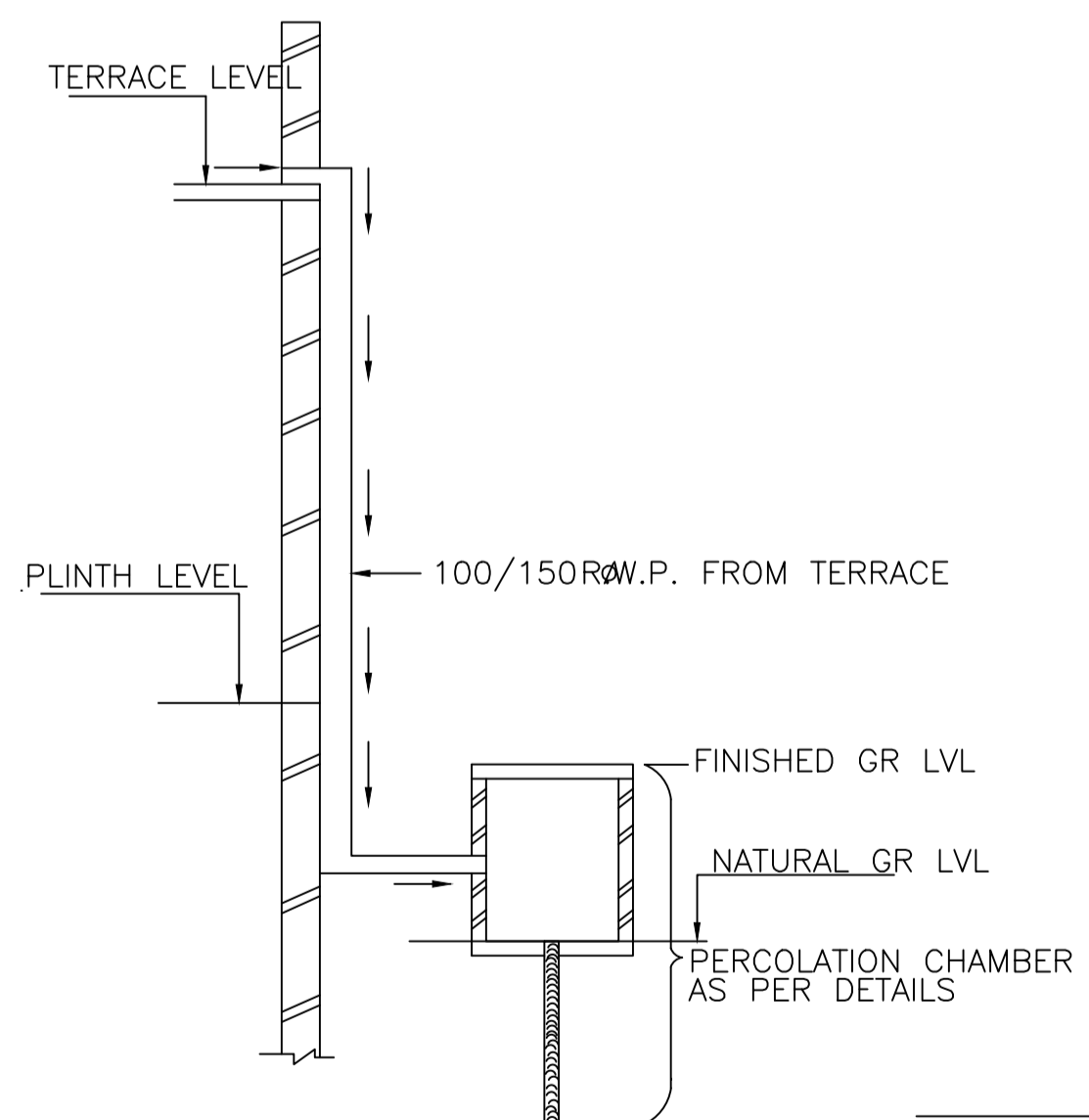
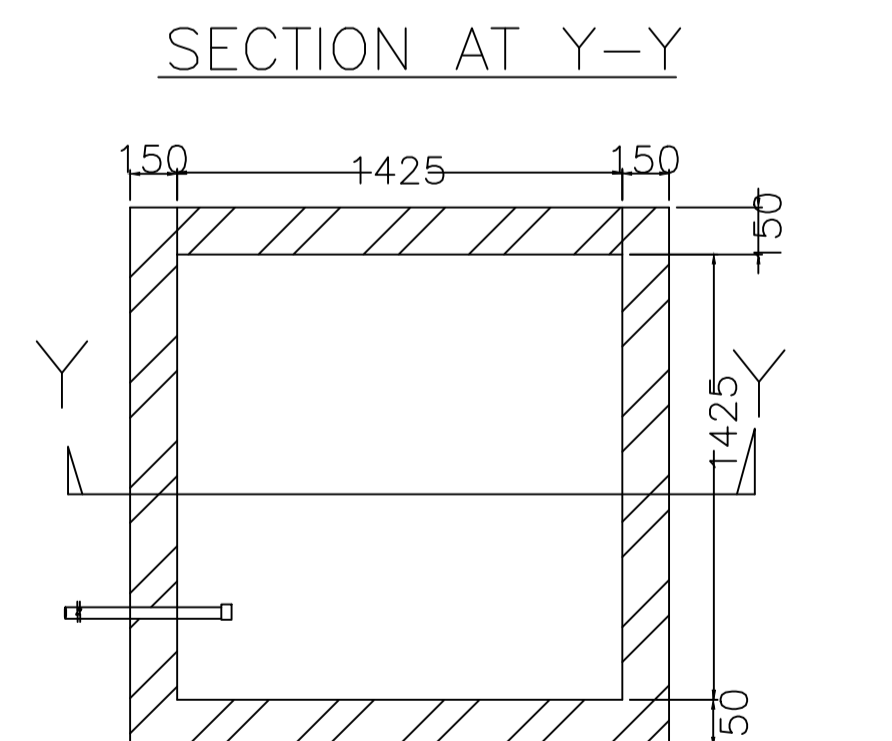
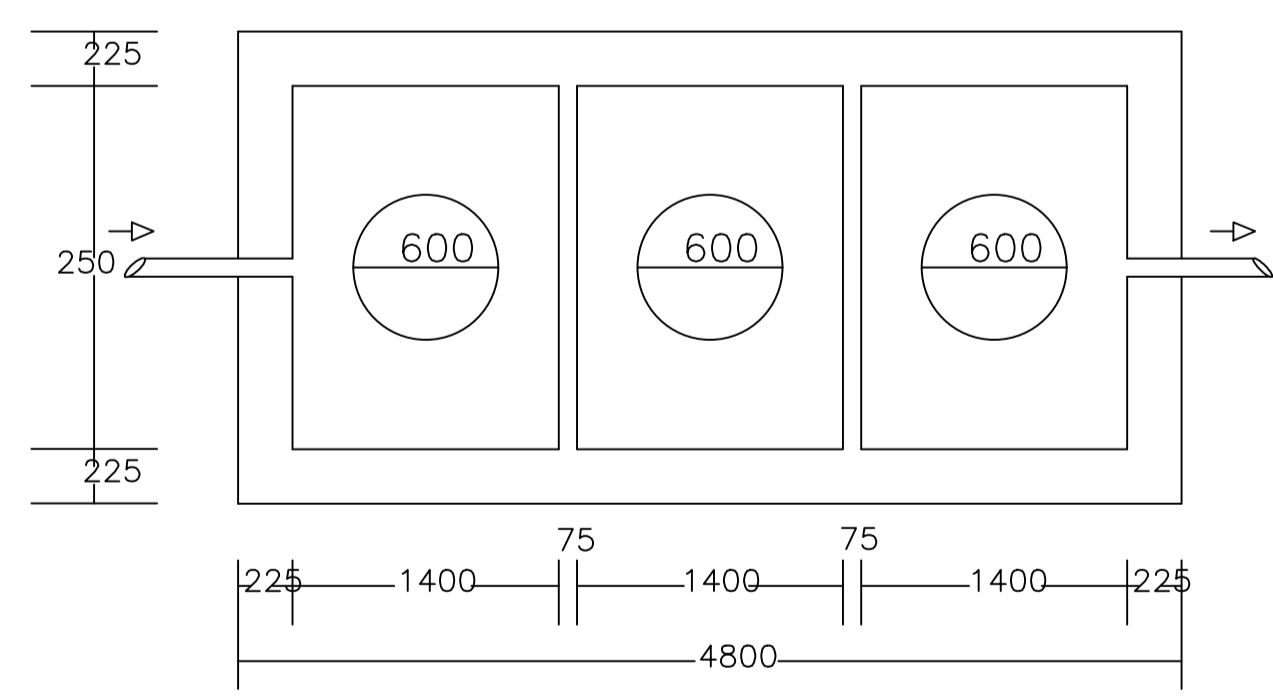
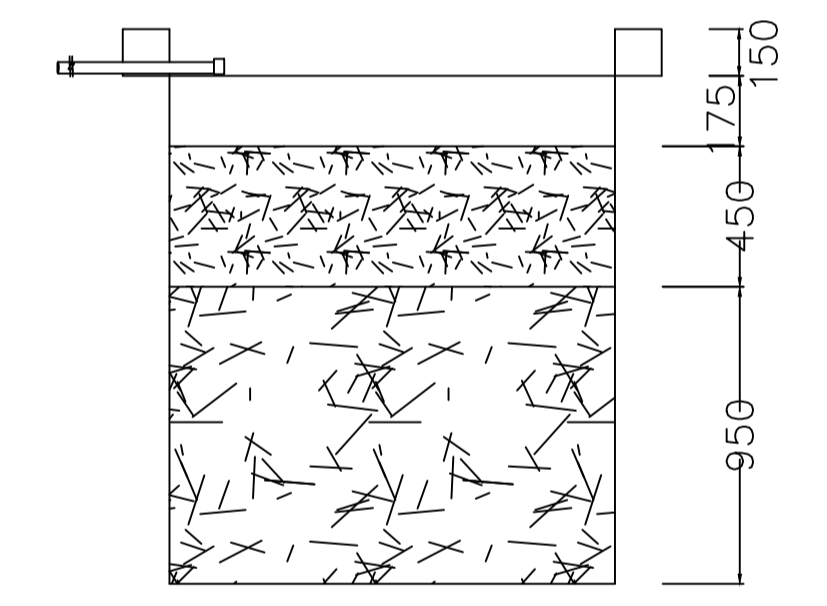
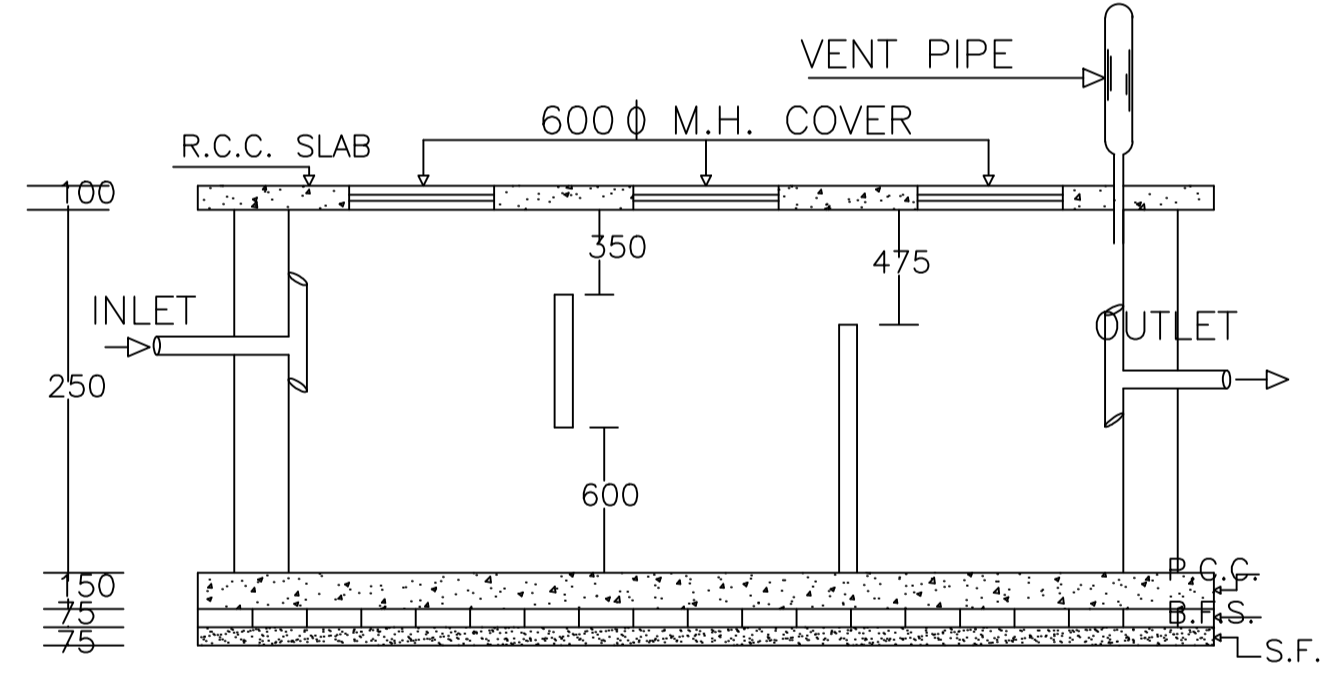
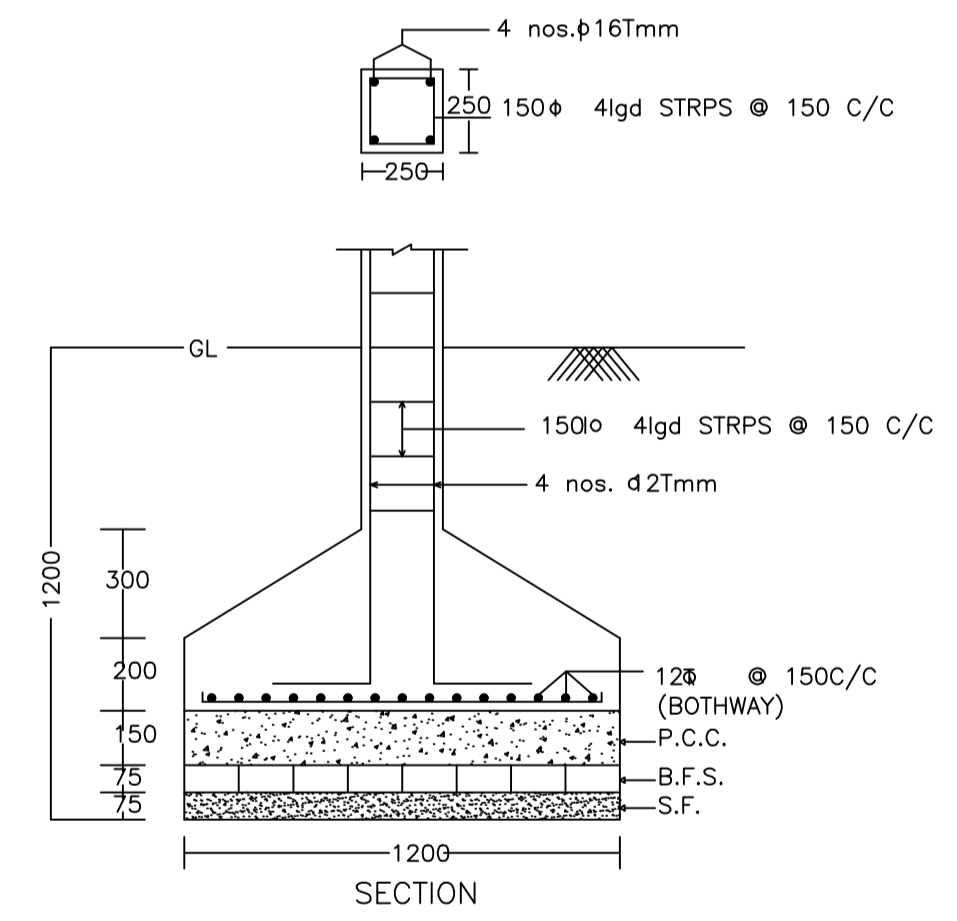
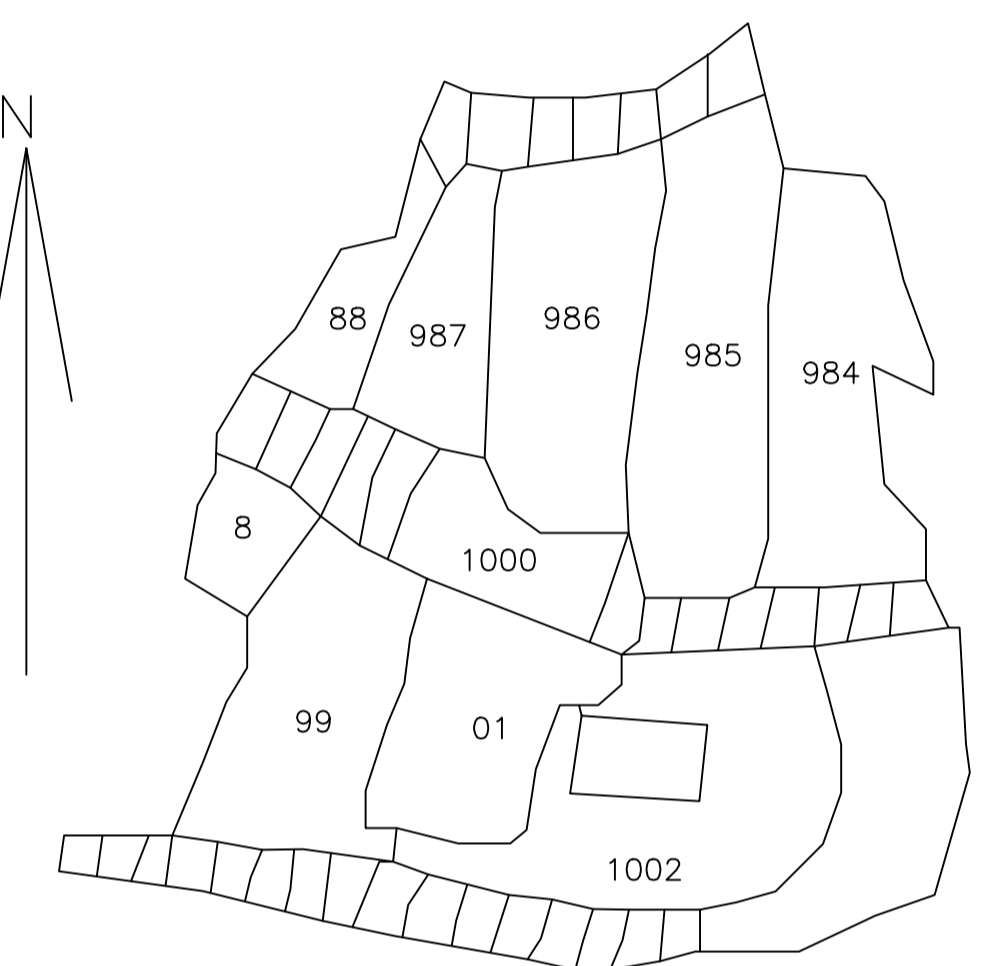
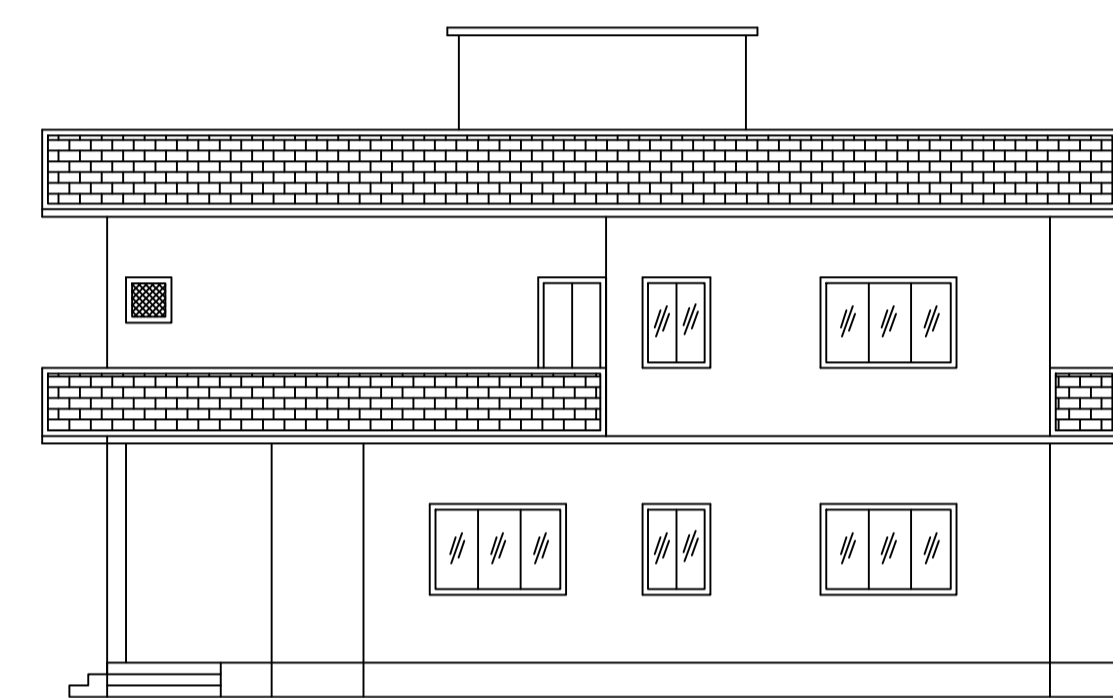
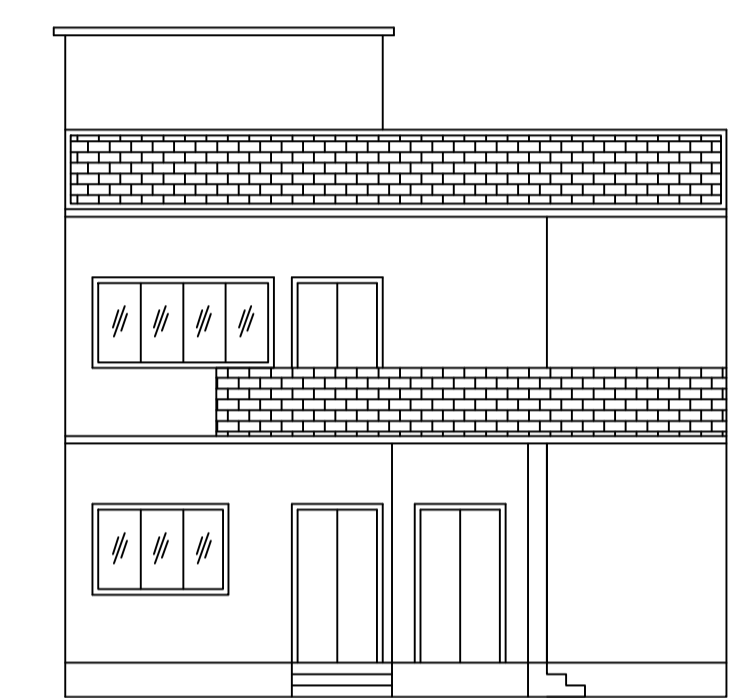
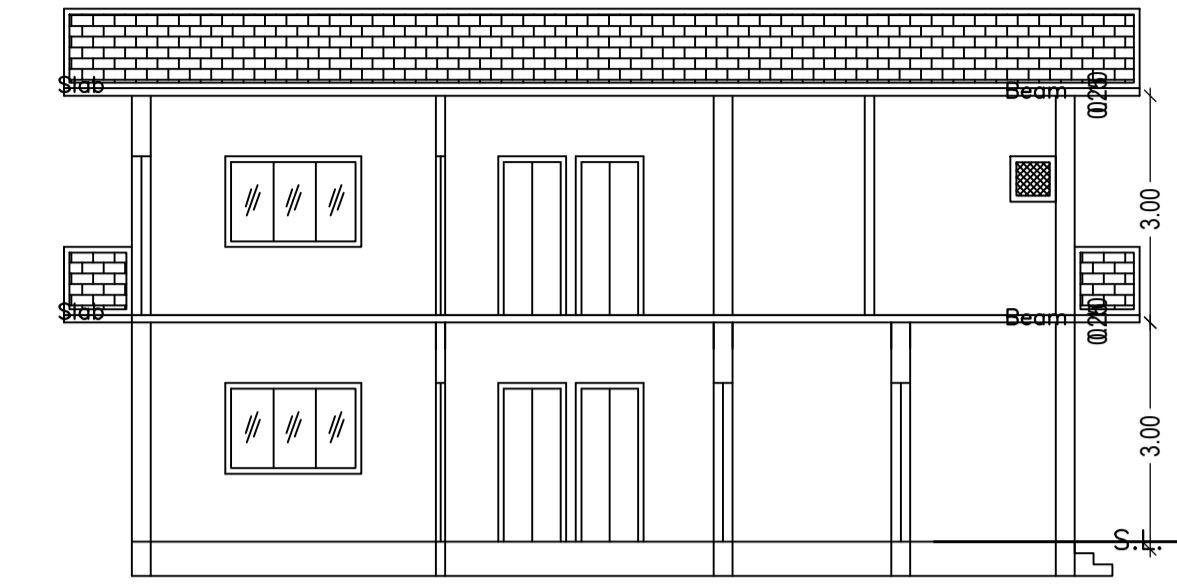
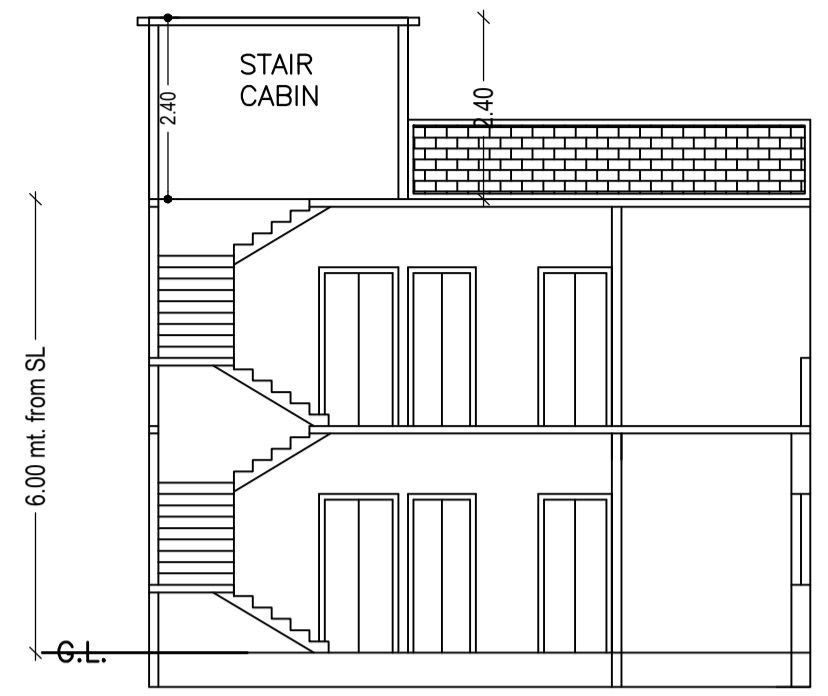
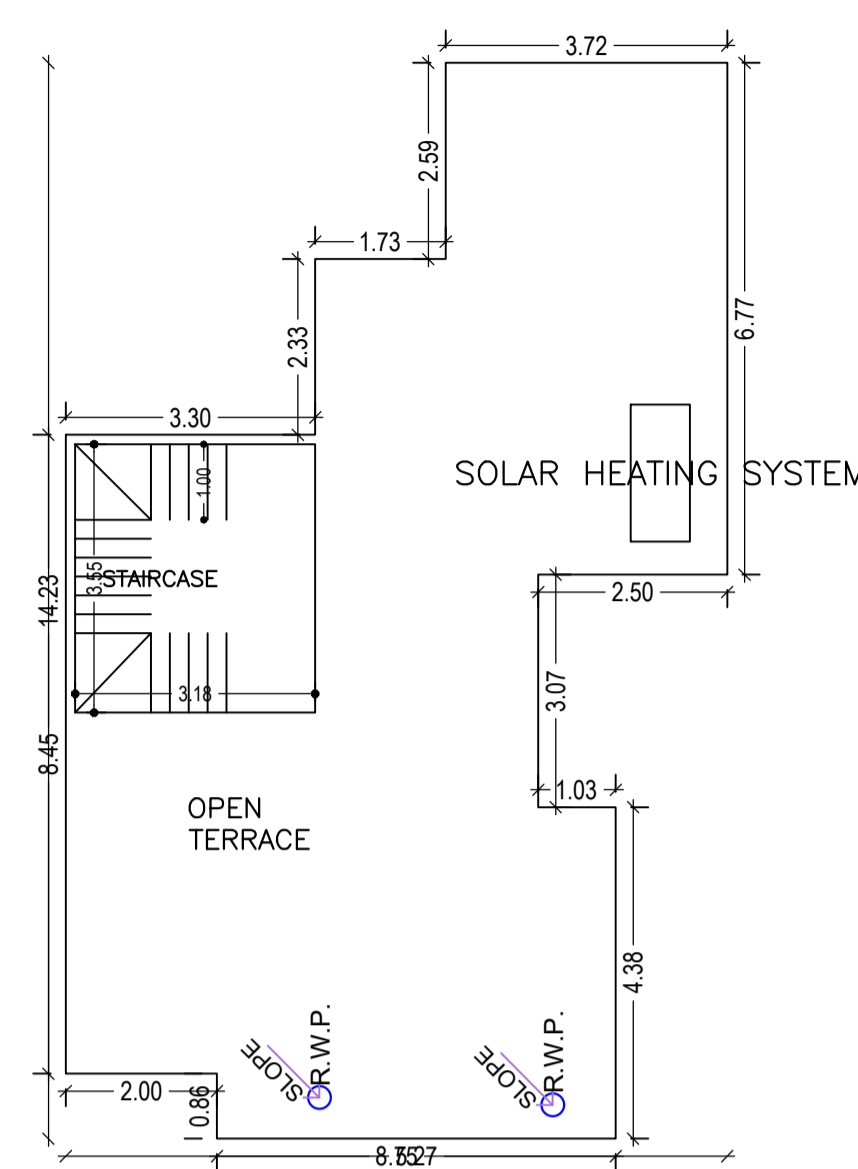
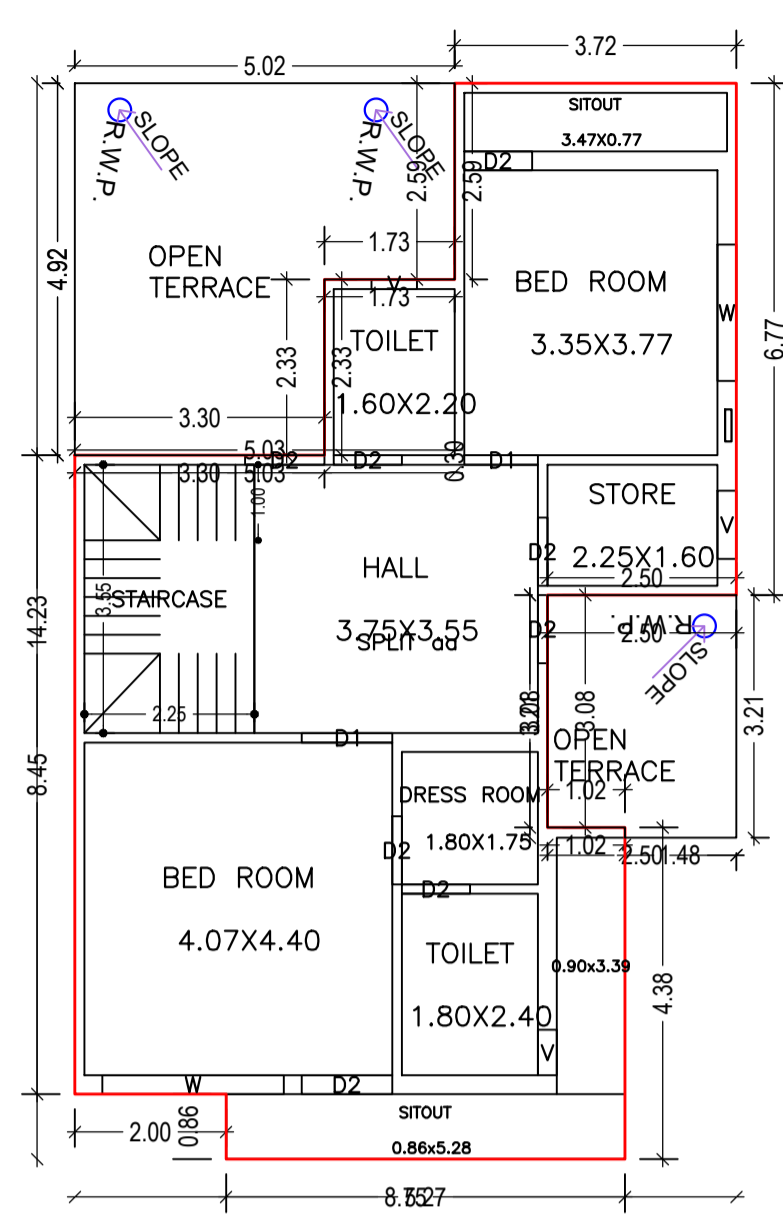
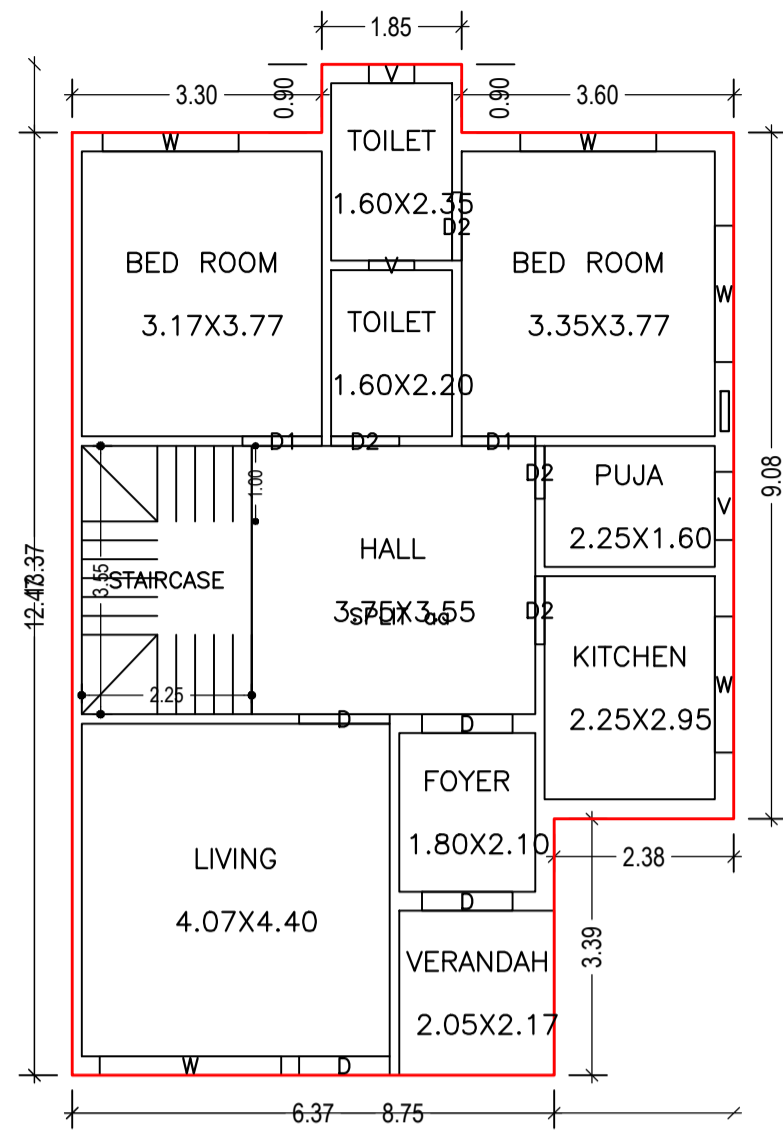

LTP NAME AND SIGNATURE	STRUCTURAL ENG'S NAME AND SIGNATURE	BUILDER NAME AND SIGNATURE	DIGITAL SIGNATURE
RAJEEV RANJAN SINGH MADA/ENG/0004/2019			